

Mop Bucket Combo Study

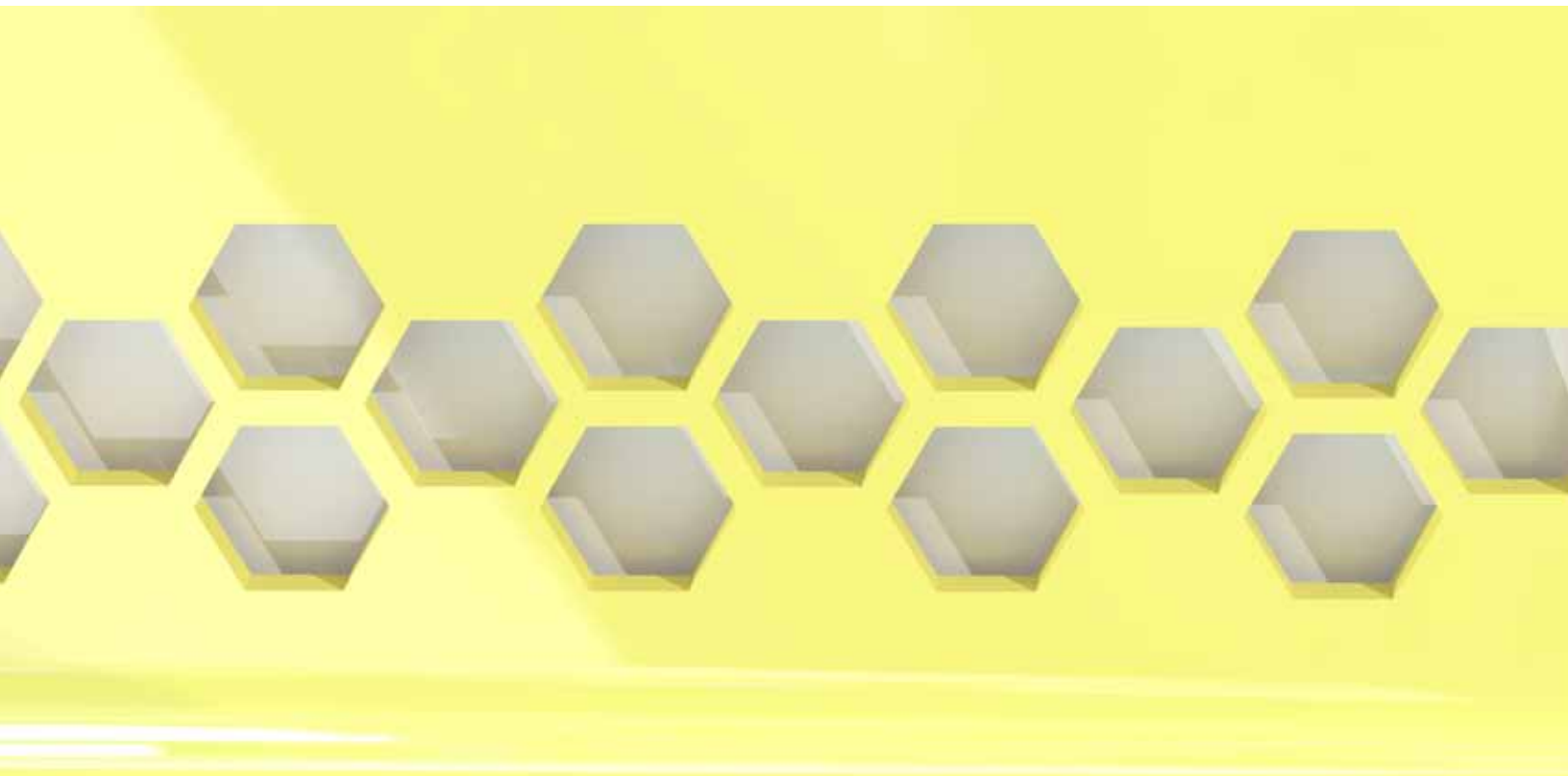

Design Process Book



Kristina Rank
Senior Industrial Design Thesis

Mop Bucket Combo Study



Table of Contents

Table of Contents



4. Design Brief

5. Research

- 5. Benchmarking
- 9. Market Matrix
- 10. Outside Research
- 15. Interviews
- 22. Personas
- 26. Outcomes

27. Concept Development

- 27. Sketches
- 31. 3-D Models
- 34. Further Development
- 36. Final Wringer Concept

38. Final Model

- 38. Orthographics
- 43. Wringer Concept
- 44. 3-D Print
- 47. Rendering

Design Brief



Problem Statement

Mop buckets are generally difficult and unwieldy to use. There are a few distinct problems that most current bucket designs do not address. They tend to be difficult to move around, with four casters a mop bucket is apt to take off in any direction. When being moved around, if the handle to the squeegee is pulled the unit pulls apart and when moving it with the mop it requires downward force in the corners of the bucket to move it in the desired direction. Mop buckets are also very difficult to empty as they get very heavy when full of water.

Concept Statement

I would like to design a commercial mop bucket/mop combo that is easier to move around the area you are trying to clean up and that can be easily emptied.

Business Goal

- Develop a new type of dispensing system making the bucket easier to empty in order to reduce the load incurred by emptying larger buckets.
- Utilize simple changes in wheel design and layout to create an easier to move bucket and keep it from rolling in strange directions.
- Keep the estimated cost of the bucket low as to not discourage people from purchasing the new model.

Primary market & distribution channels

- Businesses who mop the floor on a regular basis.
- Commercial business supply providers.

Secondary market & distribution channels

- Homeowners who prefer mops to other methods of cleaning the floor.
- Catalog/online sales.

Preliminary design considerations

- Low cost manufacturing
- New liquid storage options
- High capacity liquid container
- Non-electrical
- Affords long term use and re-use
- Re-designed movement capabilities through wheels and/or mop handle features

User profile

- Global
- Ages 18 to elderly
- Male and Female workers
- All types/sizes of business flooring
- Grease, oil, dust, dirt and debris cleaning
- Business level income

Technology/material/unique opportunities

- Newer resins possible



Research



Benchmarking





Product Benchmarks



			
<p>Rubbermaid WaveBrake Down Press Combo Mop Bucket and Wringer System</p>	<p>Quickie Easy Glide Mop Bucket with Wringer</p>	<p>Rubbermaid® Mop Bucket And Wringer</p>	<p>Genuine Joe : Mop Bucket Wringer Combo</p>
<p>\$168.00</p>	<p>\$49.99</p>	<p>\$64.99</p>	<p>\$165.70</p>
<p>44 qt.</p>	<p>5 gal</p>	<p>35 qt.</p>	<p>26 qt.</p>
<p>24in D x 38in H x 17in W</p>		<p>23.1in L x 38.1in W x 16in H</p>	
<p>21.25 lbs.</p>	<p>9 lbs.</p>	<p>19.4 lbs.</p>	<p>34 lbs.</p>
<p>*Foot pedal water evacuation conveniently located, no lifting required *Lasts 58 times longer than comparative wringers *Tested to exceed 50,000 wringing cycles, average wringers perform approx. 860 cycles *High efficiency down press wringer *Drain connector included</p>	<p>*Easy to squeeze with steel handle *Maximum wringing with little effort *Spring loaded *Large comfortable handle grip so wet hands won't slip</p>	<p>*Side press wringer *WaveBrake system reduces splashing for a safer environment, cleaner floors and improved productivity *New ergonomic wringer handle design *3" casters *Smooth, easy to clean surfaces</p>	<p>*mop bucket and wringer *splash guard system *3" nonmarking casters. *Bucket has international symbol for "Caution" printed on both sides</p>

Product Benchmarks



			
<p>Rubbermaid Comm. Tandem Bucket And Wringer</p>	<p>Leifheit 55400 Twister Strip Mop with Handled Bucket</p>	<p>Syr (Scot Young Research) 502110 "Ace" Skywasher I Mop/bucket</p>	<p>WaveBreak Mopping Trolley with Down Press Wringer</p>
<p>\$82.00</p>	<p>\$40.08</p>	<p>\$77.99</p>	<p>\$217.95</p>
<p>31 qt.</p>		<p>4 gal</p>	<p>35 qt.</p>
<p>32in H x 22.6in W x 13.3in D</p>	<p>11in W x 12in D x 55in</p>		<p>29in l. x 18in W x 38.5in H</p>
<p>11.8 lbs.</p>		<p>12 lbs.</p>	<p>42 lbs.</p>
<p>*Casters: 3" Non marking, *1 piece design with integrated bucket and wringer. *Reverse wiring mechanism allows handle to naturally align with center of the bucket for ease of use. *Dual water evacuation allows holes in both wringer plates to force more water from the mop in less time</p>	<p>*Twister mop and bucket tackle cleaning duties with efficiency and ease *Uses centrifugal force to create customized dryness levels for any job *Slender floor mop provides jointed handle and super-absorbent strips *Large bucket with carrying handle; mop tumbler prevents splashing</p>	<p>*mop bucket with wringer and dirt grid with sump area to trap dirt *Skywasher strip mop head included *Polypropylene bucket material *Rust and corrosion resistant with steel carrying handle</p>	<p>*WaveBreak Mop Bucket system reduces splashing by 40%, for safer, cleaner floors and improved productivity. *Built using tubular steel and structural web molded plastic provides this trolley with great impact resistance, strength and a smooth cleanable surface. *The high efficiency down press wringer has been tested to exceed 100,000 cycles. *The bucket-in-bucket system separates dirty water from clean water, so floors are always being mopped with clean water, reducing the risk of cross contamination. *Non-rusting casters make half the noise standard mop buckets make, allowing for a quieter work environment. *The integrated trolley handle eases transportation and provides storage for a safety sign and a lobby dust pan.</p>

Product Benchmarks



Tough Guy Down Pressure Mop Bucket/Wringer

Continental Unibody™ Side Press Mopping System

Cortech Mop Bucket and Wringer

Microfiber Finish Mop Bucket

\$108.81

\$91.81

\$111.40

\$106.93

8.75 gal 35 qt.

35 qt.

35 qt.

7 gal 28 qt.

13.5 in H x 16 in W X 20.5 L

17 lbs.

15.15 lbs.

5.2 lbs.

- *Includes Hand Operated Drain
- *Mop Bucket/Wringer Combos
- *Polypropylene Material

- *highly efficient side-press wringer.
- *one-piece design results in a positive transfer of force, increasing wringing performance
- *bucket includes a self-draining spigot with sediment screen drain grate that saves you the strain of lifting the unit to empty it.
- *This unit also has a smooth, non-porous Derma-Tek™ finish that resists chipping or cracking, does not absorb chemicals, and is easy to clean.
- *3" Non-Marking Gray Casters
- *Universal Caution Logo

- *3" Non-Marking Swivel Casters
- *Designed for use in correctional and institutional applications
- *virtually all-plastic, metal-free design reduces the ability for making weapons.

- *Plastic Carry Handle,
- *Molded In Filling Guide,
- *Snap On Air Tight Lid
- *Blue color distinguishes it from general cleaning equipment.
- *Stores unused floor finish with an airtight lid.
- *Polypropylene,
- *Injection Molded Construction,
- *Press Sieve Wringer,
- *3 In Nonmarking Casters,

Outside Products



This combo project will also include a mop. Researching mops I found that ergonomics are usually not taken into account beyond handle grips. Many of the mops I found are able to wring themselves without aid of a wringer within the bucket. This could also be an option.



In order to better understand steps that people take when they clean the floors I looked into brooms. This provided insight on acceptable ways to connect a mop head and handle configurations. Along the same lines as the mops, I did not find many ergonomic considerations.



Looking into shovels I found that many brands use ergonomics differently in the handles than cleaning products. Many of the handles are bent in order to provide easier grip and leverage.





Mop Benchmarks



			
<p>Genuine Joe 54201 Cotton Wet Mop with Handle</p>	<p>HomePro® Ring-A-Mop® With Microban®</p>	<p>Libman® Wonder Mop (4 Pack)</p>	<p>Libman Tornado Twist Mop</p>
<p>\$17.65</p>	<p>\$21.99</p>	<p>\$51.96</p>	<p>\$13.83</p>
<p>60in L</p>	<p>50in L x 2in D</p>	<p>48in L</p>	<p>55.8 x 6.6 x 4.1 in</p>
<ul style="list-style-type: none"> * No assembly required * Green Compliance * Handle Type: Wood * Head Type: Cotton * Four-ply yarn 	<ul style="list-style-type: none"> *Microban built into the brush fibers and sponge. Microban is designed to protect against bacteria, mold and mildew that can cause odors and product deterioration. *Patented wringing mechanism that is super-fast and super-easy — 5 amazing rollers do all of the wringing. Simply push down to wring out. *Equipped with a 48” powder-coated steel handle with hang-up feature. 	<ul style="list-style-type: none"> *For wet mopping *Non-woven premium synthetic material *Absorbent machine washable *Special wringer sleeve - more holes and deeper groovers wring more water *Your hands never touch water *Great for all surfaces - hardwood, ceramic tile, linoleum and stone 	<ul style="list-style-type: none"> *Green bands prevent tangling *Easy to use, no buttons *Hands never touch the water *Wringing mechanism on the Tornado Mop® is incredibly simple, the unique ratchet design allows for maximum wringing without the hassle of release buttons or the annoying tendency of a normal mop head to flip back *Ratcheting wringing mechanism locks and holds with each twist





Broom Benchmarks



			
<p>Crowley Jones Compact Broom w/telescoping handle and Attachable Dustpan</p>	<p>Oxo Good Grips Broom</p>	<p>Harper Brush Works 24-Inch Heavy Duty Border Push Broom</p>	<p>As Seen On Tv 217412 One Sweep Broom</p>
<p>\$15.44</p>	<p>\$22.50</p>	<p>\$29.99</p>	<p>\$29.99</p>
<p>7 x 3 x 29.5 in ; 2 lbs</p>	<p>9 x 2 x 53.5 inches ; 1.5 lbs</p>	<p>6 x 48 x 6 inches ; 3.5 lbs</p>	<p>3lbs</p>
<p>*Broom-and-dustpan unit in a smart, space-saving design *Twist-operated telescoping handle extends to 47 inches *Articulating head for maximum reach; 4-inch bristles *Includes attachable 6-1/2-by-1-1/2-by-18-inch dustpan</p>	<p>*Broom length eliminates the need to bend *Angled bristles for maximum cleaning efficiency *Soft, comfortable handle *Hanging hole for storage *10-inch bristle width</p>	<p>*2 brooms in 1, medium-stiff center bristles sweep up the heavy debris, while the fine split-tip border bristles sweep up the fine dust *Medium surface pushbroom *Durable hardwood handle *Heavy-duty metal tip *Sturdy hardwood block</p>	<p>*Great for the garage or around the pool; for drywall, sawdust, grass, leaves or sand *Even works incredibly well on carpet! *For high traffic areas, steps or stairs, goes deeper than even the most expensive vacuum cleaner, pulling out tough customers like pet and human hair *Cleans wood floors without scratching *Terrific for ceramic tile -- gets into the grout, and hard-to-reach areas -- even corners</p>





Shovel Benchmarks



			
<p>Suncast 18-Inch Snow Shovel/Pusher Combo w/ Ergonomic Shaped Handle, Wear Strip</p>	<p>Ames True Temper Classic Round Point Shovel With 30-Inch D-Grip Handle</p>	<p>Garant Yukon Ergonomic Sleigh Shovel Poly Scoop Steel Wear Strip and Steel Handle</p>	<p>Ames True Temper Penguin SnoBoss Pusher and Shovel Poly Blade w/Steel Wear Strip</p>
<p>\$26.99</p>	<p>\$19.99</p>	<p>\$72.44</p>	<p>\$35.59</p>
<p>18 x 12 x 52.5 in ; 3.5lbs</p>	<p>39.5 x 1.5 x 8.5 inches ; 5.2 lbs</p>	<p>27.5 in ; 6 lbs</p>	<p>24 in ; 5.7 lbs</p>
<ul style="list-style-type: none"> *Ergonomic Bent Handle *Galvanized Steel Wear Strip *Ribbed Steel Core handle 	<ul style="list-style-type: none"> *30-Inch D-Grip Handle 	<ul style="list-style-type: none"> *Blue Poly scoop *Steel wear strip for extended blade life *Ergonomic steel handle *Label listing the features and benefits of the product *Designed for intense and continuous use 	<ul style="list-style-type: none"> *26-inch High capacity blade with wear strip that can be used as pusher or shovel *Ergonomist designed midgrips and end grip for optimal hand placement/back posture when lifting *Foot step for maximum leverage *Single piece, lightweight aluminum handle *Reversible for tight steps and stairs

Other Benchmarks



			
<p>Genie Microfiber Cleaning Slippers</p>	<p>Black & Decker S700E Scum-Buster Xtreme Cleaning Tool with 3-in-1 Extension Handle</p>	<p>Butler Home Products Mr Clean Magic Eraser Squeeze Mop</p>	<p>Oxo Good Grips Upright Broom and Dustpan Set, Silver</p>
<p>\$11.35</p>	<p>\$43.40</p>	<p>\$14.99</p>	<p>\$24.99</p>
<p>10.2 x 4.5 x 0.8 inches ; 7 oz</p>	<p>19.2 x 4.8 x 7.8 inches ; 3.6 lb</p>	<p>3.5 x 9.8 x 53.5 inches ; 2.2 lbs</p>	<p>38.2 x 9.3 x 3.3 inches ; 8 lbs</p>
<p>*Open toe slipper with microfiber fingers that catch hair, dust and dirt; one size fits most *Cleans faster, easier and better; slippers can go where mops cannot *Velcro pad attaches/detaches cleaning cloth from slipper *No hard edges, so safe to use on all floor surfaces-- including wood, tile, vinyl *Machine washable; for use on dry floors only</p>	<p>*Single-speed roller brush with powerful motor for cleaning household surfaces *Rechargeable battery provides 25 to 30 minutes of runtime *3-in-1 extension handle offers extended reach and rinsing capability *Fully submersible; interchangeable accessories; scour pad and charger included</p>	<p>*Magic Erasers deep penetrating action gets out grime and dirt trapped in grooves and surfaces *Highly absorbent *Safe for use on vinyl, tile, marble, stone, and non-wax floors *The Magic Eraser you love now as a mop</p>	<p>*Upright broom and dust pan set snap together and store compactly *Broom features soft padded handle and oval shape for secure fit in hand *4-cup dust pan locks in place for better control; rubber lip provides maximum floor contact *Dustpan swivels upright and broom nests inside for a slim, neat profile</p>

Research



Interviews

Interviews



I performed approximately 20 interviews with different people to learn what process they use when they clean the floor. Also throughout the process I have been interviewing people at various jobs about their habits when they mop the floors. My basic questions are as follow.

Gender, Age, Occupation

1. What type of environment are the floors that you clean in?
2. How often do you clean the floors?
3. What tools do you use for said cleaning?
4. What kind of bucket do you use?
5. If you use a bucket, how often do you refill it? How do you empty it?
6. How do you move it around?
7. How much time do you usually spend?
8. What are your steps when you clean the floor? (ie: dump water on floor, hose)

From these interviews I was able to learn a few details.

-Companies and Businesses

Have the floor cleaned at least once a day.

Use a standard mop bucket with no special features like a water evacuation systems.

Most people move the bucket around by shoving the mop into the corners of the bucket.

Many listen to music while mopping.

For food service type jobs hose off the floor before mopping it.

Businesses and schools use the damp mop after it's been wrung out.

-Individual homeowners/renters

Clean the floors about once a month.

Use either a simple bucket or a swiffer.

People who use the bucket usually use a rag to wipe the floor.

I posted the same questions on an online survey and got similar responses. Some larger businesses use a machine with a micro fiber mopping system.

Formal Interview Responses



Gender, Age, Occupation

Female, 50's, Receptionist

1. What type of environment are the floors that you clean in?

The floors in my own house

2. How often do you clean the floors?

I clean my hardwood floors about once a month

3. What tools do you use for said cleaning?

I clean the floor by hand with a rag and a bucket

4. What kind of bucket do you use?

I use a standard small household bucket

5. If you use a bucket, how often do you refill it? How do you empty it?

I will refill the bucket about 3 times, Pick it up and dump

6. How do you move it around?

I lift the bucket

7. How much time do you usually spend?

About an hour and 15 minutes

8. What are your steps when you clean the floor? (ie: dump water on floor, hose)

First I vacuum, take everything off the floor, grab the bucket, make a soap mixture, grab a clean rag and towel and wipe down the floors rinsing the rag and getting new water when needed.

Gender, Age, Occupation

Male, 20's, School Janitor

1. What type of environment are the floors that you clean in?

My job is to clean the floors in the hallway at a school

2. How often do you clean the floors?

Every day

3. What tools do you use for said cleaning?

Mop, bucket, water

4. What kind of bucket do you use?

I use a standard commercial mop bucket

5. If you use a bucket, how often do you refill it? How do you empty it?

Refilled twice, I lift it up and pour it into the sink

6. How do you move it around?

Stick the mop in it and drag it around

7. How much time do you usually spend?

30-45 minutes, for all the hallway floors

8. What are your steps when you clean the floor? (ie: dump water on floor, hose)

Standard mop bucket procedure, fill with water, wring out mop, clean the floor, rinse out mop and repeat

Formal Interview Responses



Gender, Age, Occupation

Male, 26, Panera bread

1. What type of environment are the floors that you clean in?
After closing at Panera bread
2. How often do you clean the floors?
Once every night
3. What tools do you use for said cleaning?
Mop, mop bucket, large squeegee, deck scrubber
4. What kind of bucket do you use?
I use a mop bucket with a wringer
5. If you use a bucket, how often do you refill it? How do you empty it?
Refill after 1-3 uses, empty contents in a drain after use
6. How do you move it around?
I hold onto the handle you use to press out water
7. How much time do you usually spend?
10-15 minutes, depends on if I have to get icing off
8. What are your steps when you clean the floor? (ie: dump water on floor, hose)
Sweep floor, mop floor and if there is water on the floor squeegee it into the drain and if there is icing on the floor deck scrub after mop or pour really hot water on it to break it up, then get at it with a rag.

Gender, Age, Occupation

Female, 53, residential cleaning company owner

1. What type of environment are the floors that you clean in?
All types of environments, mostly office buildings
2. How often do you clean the floors?
Every day
3. What tools do you use for said cleaning?
Brooms, dust mops, damp mops, micro fiber mopping systems and vacuums
4. What kind of bucket do you use?
Most of the time we use a self feeding micro fiber mopping system for larger area flooring
5. If you use a bucket, how often do you refill it? How do you empty it?
N/A
6. How do you move it around?
N/A
7. How much time do you usually spend?
Varies based on type of flooring and method used to clean each
8. What are your steps when you clean the floor? (ie: dump water on floor, hose)
Sweep or dust mop vacuum damp mop or wash floor

Formal Interview Responses



Gender, Age, Occupation

Female, 21, Graduate Student

1. What type of environment are the floors that you clean in?
The floors in my own house
2. How often do you clean the floors?
Once a month
3. What tools do you use for said cleaning?
Broom, Mop, lemon scented cleaner
4. What kind of bucket do you use?
I use a 5 gallon bucket
5. If you use a bucket, how often do you refill it? How do you empty it?
I only fill it once were a cleaning session, I dump it out in the sink
6. How do you move it around?
I also move it around as I go.
7. How much time do you usually spend?
25 minutes
8. What are your steps when you clean the floor? (ie: dump water on floor, hose)
Sweep the floor, Sweep dirt into the dustpan. Fill the bucket with warm water and lemon cleaner. Dip mop and scrub floor. Rinse And repeat until the floor is clean.

Gender, Age, Occupation

Female, 20, Student

1. What type of environment are the floors that you clean in?
The small area of tile in my kitchen
2. How often do you clean the floors?
About once per month
3. What tools do you use for said cleaning?
Swiffer mop
4. What kind of bucket do you use?
I do not usually use a bucket
5. If you use a bucket, how often do you refill it? How do you empty it?
Rarely use a bucket, but when one is used I refill once, empty it twice into the sink
6. How do you move it around?
Pick it up and carry it around
7. How much time do you usually spend?
15 minutes, for 40 sq. ft.
8. What are your steps when you clean the floor? (ie: dump water on floor, hose)
Put solution on the floors, soak it up with the swiffer cloth, dry.

Formal Interview Responses



Gender, Age, Occupation

Female, 23, Sonic

1. What type of environment are the floors that you clean in?
In the evening at a fast food restaurant
2. How often do you clean the floors?
Once every night
3. What tools do you use for said cleaning?
Hose, soap, scrubby brush, mop, mop bucket, large squeegee
4. What kind of bucket do you use?
I use a mop bucket with a wringer
5. If you use a bucket, how often do you refill it? How do you empty it?
I usually use the same water for the whole floor, water gets dumped into a trough in the back
6. How do you move it around?
I shove the mop into the corners of the bucket guiding it by holding onto the wringer
7. How much time do you usually spend?
30-45 minutes
8. What are your steps when you clean the floor? (ie: dump water on floor, hose)
Soak the whole floor with a hose, apply soap and scrub into floors with the scrubby brush, rinse soap away with water, squeegee the floor to get rid of most of the water, than mop to dry.

Gender, Age, Occupation

Female, 25, Manager at Sonic

1. What type of environment are the floors that you clean in?
Dusty floor conditions after making onion rings
2. How often do you clean the floors?
Every day
3. What tools do you use for said cleaning?
Broom, mop, mop bucket
4. What kind of bucket do you use?
Commercial mop bucket
5. If you use a bucket, how often do you refill it? How do you empty it?
Only one time
6. How do you move it around?
I kick the bucket around with my feet
7. How much time do you usually spend?
It depends on how much of the powder got onto the floor, usually 20 minutes
8. What are your steps when you clean the floor? (ie: dump water on floor, hose)
I sweep the majority of the dust off of the floor than clean up the rest with the mop wringing it out often because it gets dusty very fast

Formal Interview Responses



Gender, Age, Occupation

Female, 20, Taco Bell

1. What type of environment are the floors that you clean in?
Greasy floors with lots of food scraps
2. How often do you clean the floors?
Every day
3. What tools do you use for said cleaning?
Broom, mop, bucket
4. What kind of bucket do you use?
Mop bucket
5. If you use a bucket, how often do you refill it? How do you empty it?
Usually refilled twice, once with food chunks, second with soap and grease, dumped out into a sink
6. How do you move it around?
I drag the bucket around using the mop
7. How much time do you usually spend?
About an hour
8. What are your steps when you clean the floor? (ie: dump water on floor, hose)
Sweep the floor, mop over in the corners to get the larger food particles, empty bucket, put soap in the new water and scrub the grease off of the floor with the mop.

Gender, Age, Occupation

Male, 32, Best Buy

1. What type of environment are the floors that you clean in?
Retail
2. How often do you clean the floors?
Once per day
3. What tools do you use for said cleaning?
Mop or floor cleaning machine
4. What kind of bucket do you use?
The large yellow buckets
5. If you use a bucket, how often do you refill it? How do you empty it?
When I do use the bucket I refill it whenever the water looks dirty, about 3 times into a large sink
6. How do you move it around?
Push the mop around into the corners of the buckets and hope it rolls the way I want
7. How much time do you usually spend?
About an hour and a half
8. What are your steps when you clean the floor? (ie: dump water on floor, hose)
Fill the bucket with water, mop along the floor picking up any dust from people walking, wring it out and refill whenever the water looks dirty

Research



Personas

Personas



Tonya the Fast Food Store Owner

Tonya is a 37-year old fast food store owner in a small suburban city. Her store relies on actual foot traffic from the surrounding communities. She employs a number of employees and asks them to clean the floors nightly. Of course, this gets neglected fairly often as the employees choose not to hassle with difficult equipment.

- *Disappointed with the condition of the floors at her store
- *Has not spent any money on additional cleaning supplies
- *Has not had any luck encouraging employees to take proper care of the floors
- *Can be convinced to make a small investment

Needs

- *A way to give employees a hassle free way to clean the floor
- *To have a cheap solution to difficult cleaning equipment
- *Reassurance that her investment will provide the needed change in productivity

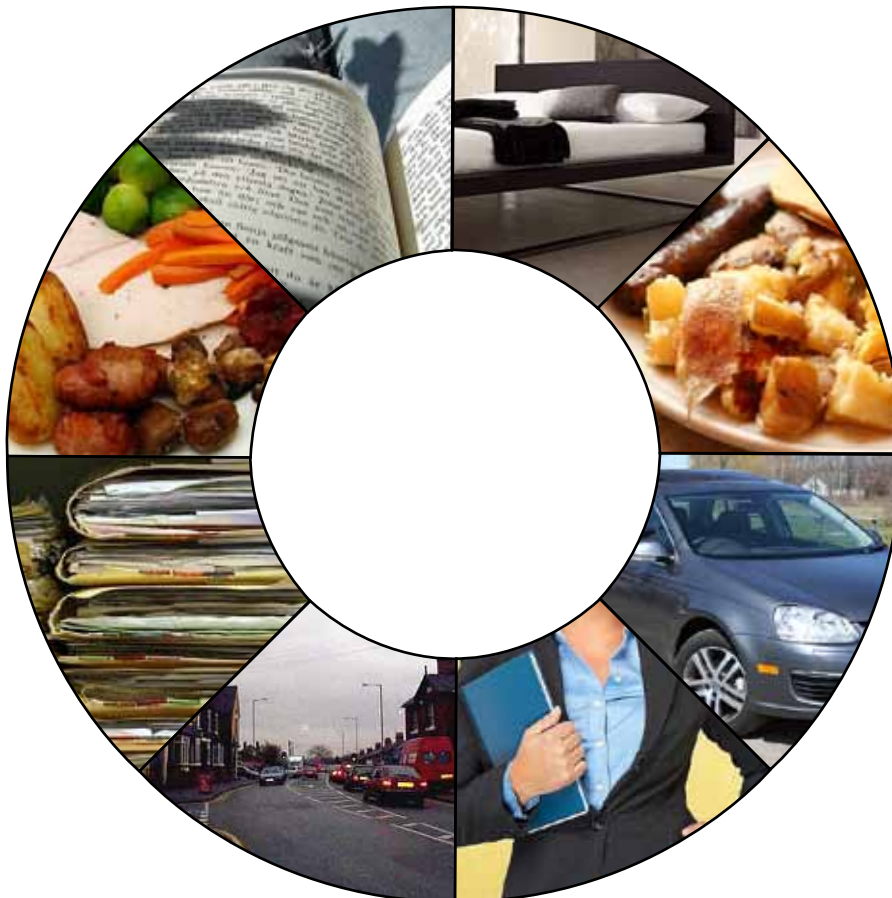

- *Wakes up in the morning
- *Eats a good breakfast
- *Drives off to check on stores
- *Checks in on stores
- *Drives between stores
- *Fills out paperwork
- *Eats a good dinner
- *Reads a book before bed

Personas



Chris the Retail Store Employee

Chris is a 20-year old retail store employee in a large suburban community. He's been working at the same store for almost three years now and has gotten pretty comfortable and regrettably, fairly lazy. One of his least favorite jobs is cleaning the floors. If he even makes an attempt at cleaning them in the evenings, it turns into a fairly rushed, sloppy job. He would like to do a better job, but it just takes so much effort.

- *Not as motivated as he should be
- *Dislikes cleaning the floor because of the effort involved
- *Doesn't know what would convince him to clean the floors
- *Has no tie to money involved with supplies in the store

Needs

- *Something to make cleaning the floors easy



- *Wakes up in the morning
- *Grabs a granola bar on the way out
- *Ride the bike to school
- *Attends classes
- *Studies
- *Eats fast food for dinner
- *Heads to work for the night shift
- *Watches TV before bed

Personas



Betty the Retired Widow

Betty is a 67 year-old mother of four children and the grandmother of twelve. She still lives in her own home and prides herself in keeping it looking just as good as she was able to when she was younger. Getting older and with two cats this is starting to be a bit more of a task than she'd like it to be.

- *Middle-class living on a fixed income
- *Doesn't like things messy and spends a lot of time organizing
- *Has trouble keeping the floor clean because of difficulty bending and twisting

Needs

- *A way to clean the floors that doesn't put too much strain on her body
- *Something simple to use without complicating functions
- *An affordable solution



- *Wakes up in the morning
- *Eats oatmeal for breakfast
- *Plays golf with some friends
- *Tends to her garden
- *Has tea
- *Eats an early dinner
- *Dusts and cleans up the house
- *Calls family/friends before bed

Outcomes



I learned that there are a lot of different kind of mop buckets, all of which have the same basic mechanisms. They hold water, have a type of wringing device and they have wheels. The difference between them is mostly price. Some of the more expensive mop buckets have added features or engineering.

Benchmarking both shovels, brooms and mops has shown me that for the most part ergonomics aren't really taken into account with mops and brooms but many shovels have some ergonomic features built in. I feel that integrating some changes to the way pressure is applied to the wringer and creating a more comfortable way to hold onto handles will help make this a stronger product.

My interviews pointed out some problems

- Often a floor drain is not used to empty the bucket, but instead dumped out into either a trough or sink.
- The casters on the bucket make moving it around a pretty wonky experience.
- The wringer is difficult to use to move the bucket because it pulls off easily.
- Handle on many buckets are small and painful to grip for dumping.

Some ideas I have gotten from research, interviews and personal experience mopping floors at work are:

- A way to move the bucket around with the mop itself.
- A stronger connection between the wringer and the bucket so it can serve as a handle.
- Pour spigot or hose attachment.
- Multiple buckets within the main bucket.
- A soap insert.
- A grate on the bottom to separate larger dirt particles.
- Pairing a mop which can wring itself with a bucket.
- Utilizing a pair of stationary wheels to help keep the bucket rolling in the proper direction.

Concept Development



Sketches

Initial Sketches

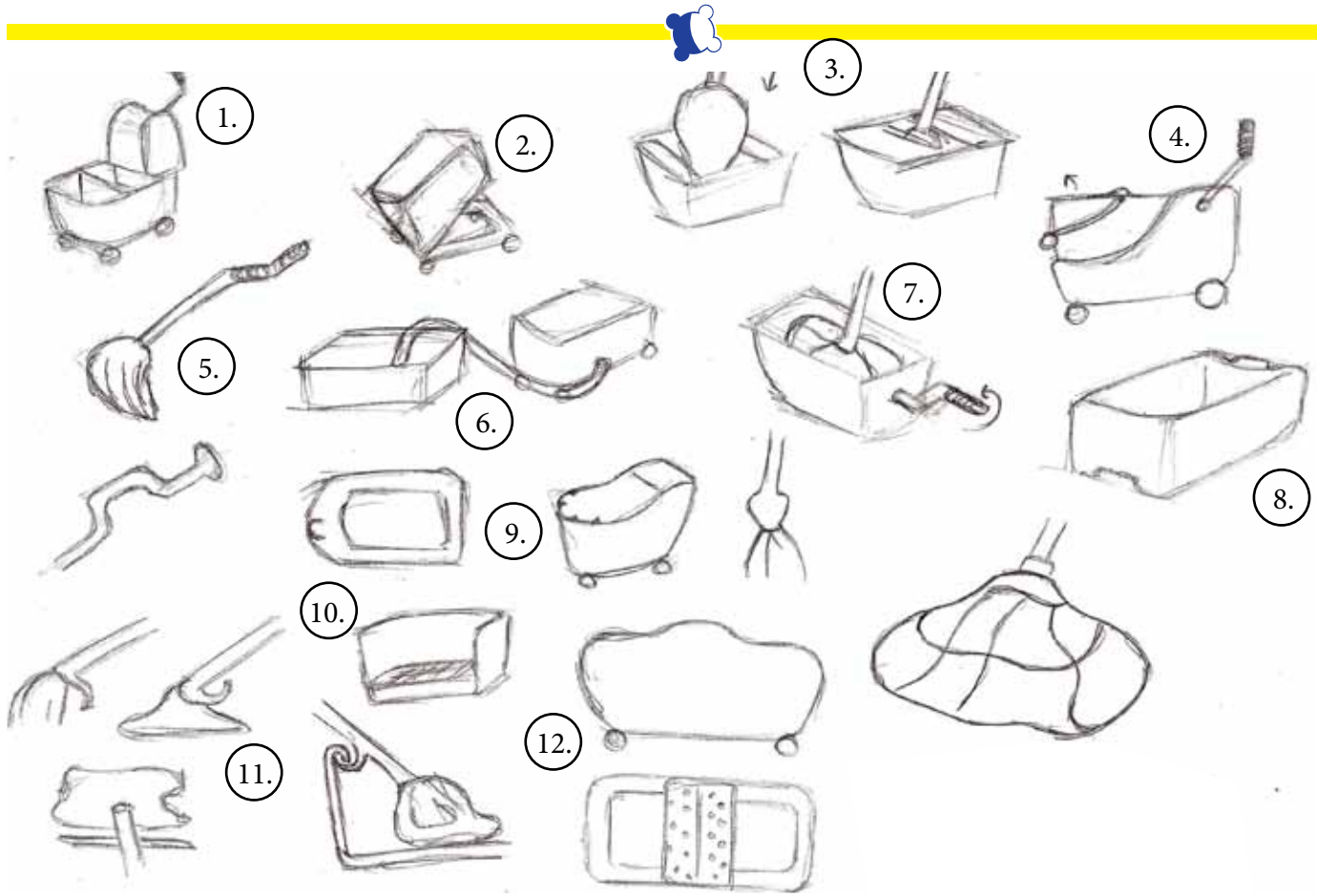

These sketches covered the basics of my ideas and were a quick way to start actually looking at them on paper.

My main concepts are:

1. Bucket with 2 distinct sections helping keep the water cleaner, longer
2. Pivot point on a chassis in order to help make the tip easier
3. Redesign of the wringer to subtract the handle and squeeze the mop with downward force
4. Loose bucket that one can remove from a base
5. A bend put into the mop handles in order to help with ergonomics
6. Siphon system for drainage
7. A more screw-like wringer
8. Hand grips on the back of the bucket to provide a strong base to grip off of while dumping
9. Semi circles placed around the bucket catch rings on the mop itself and allow you to move the bucket
10. A grated bottom plate to keep larger dirt particles from getting caught in the mop again
11. Hooked mops to catch on a lip of the bucket to move it
12. Split bucket design with down force wringer placed in the center

Further Development

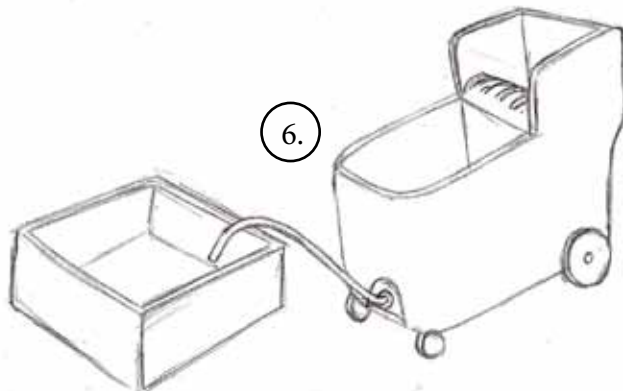
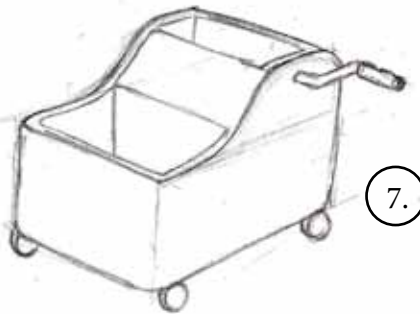
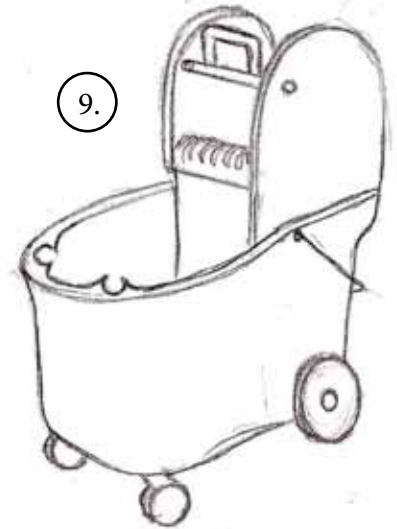
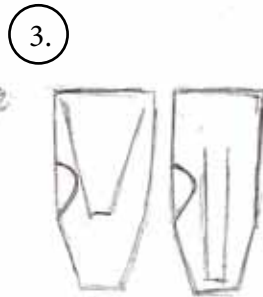
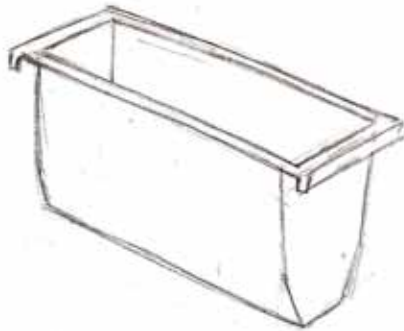
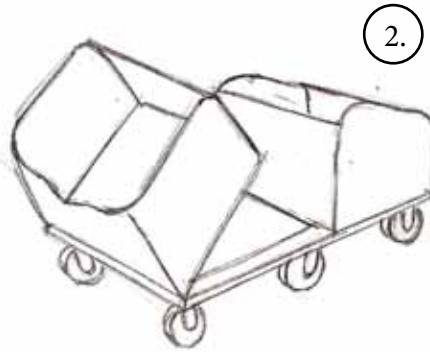

Mop Development



I explored how people use the mop bucket for ergonomic purposes and scale.

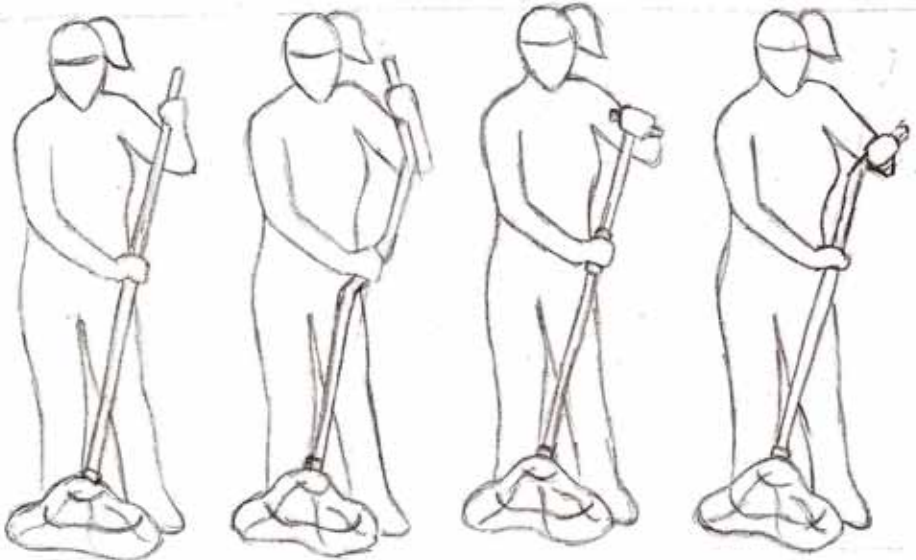

When thinking about how the mop could be more comfortable to use I looked into possible bends and end pieces for the mop handle.

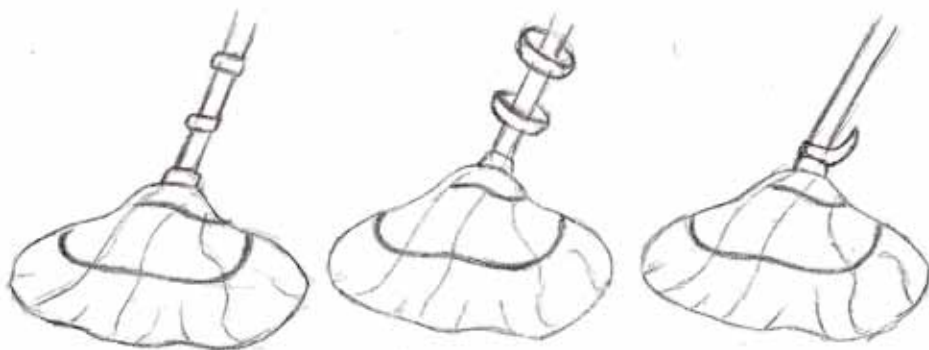

For my concept of pulling the bucket with the mop I looked into ring for the semi circle concept and hooks for the rolled lip concept

Concept Development



3-D Models

3-D Mop Development



On a straight mop I found that there weren't too many comfortable positions I could get my hands into in order to put good pressure into the mop.

What I found was that my right hand would naturally grip at the very end of the handle in order to use some force from my palm



With one bend I found that my right hand rested much more easily on the mop and I was able to put more pressure from my arm into that handle.

I was worried about the mop flipping around when the handle was bent but with this particular setup I did not have trouble keeping the mop in the direction I intended.



One I began to add more than one bend to the mop it started becoming a bit awkward to grab. I couldn't seem to grab a double bent mop in a comfortable position.

This particular setup also starts flipping out in random directions which warp your hands and arms into strange positions.

Initial Wringer Concept Mock-up



For my redesign of the mop wringer I wanted to use the idea of a down force wringing method. This type of wringer would be placed near the center of a mop bucket to prevent the bucket from tipping over when the mop is being wrung out.

The way this concept works is with a platform based off of springs at the base of the wringer. When these springs are depressed with the mop the sides of the are pressed inwards by protrusions. This inward collapsing would cause the water to squeeze out of the mop without a need of a handle.

One side of the outer wringer would be grated to allow water to flow out into one of the side buckets. Both inner wringers would be grated. This particular model still needs some refining and measurements but it proves my idea can work.



Further Wringer Development

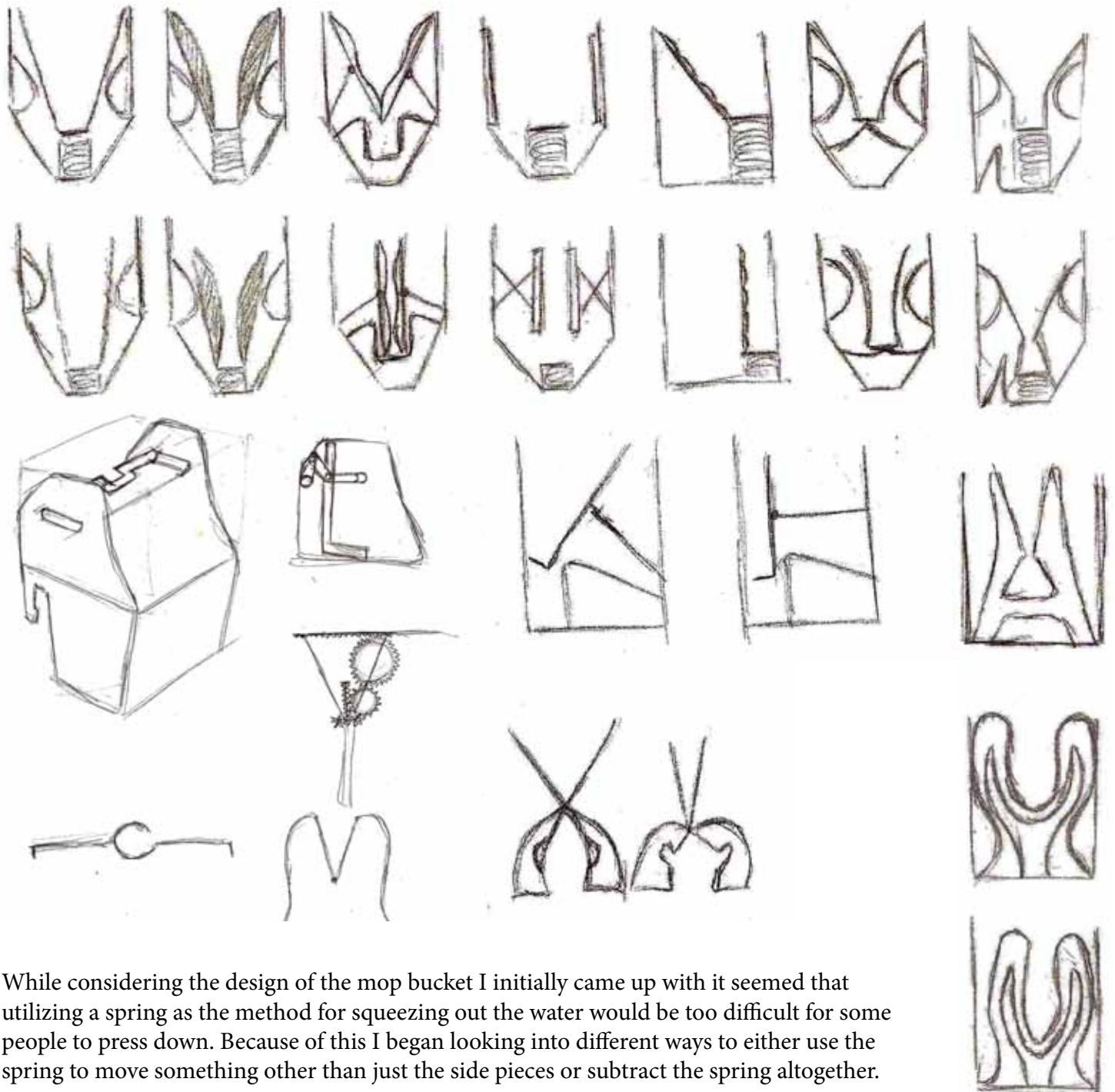

While considering the design of the mop bucket I initially came up with it seemed that utilizing a spring as the method for squeezing out the water would be too difficult for some people to press down. Because of this I began looking into different ways to either use the spring to move something other than just the side pieces or subtract the spring altogether.

Wringer Concepts



This concept is based off of the idea of using a living hinge. By creating a flexible form with a bend in the middle, when something is pushed into the middle the two side pieces press inwards. With this model I found out that the whole form could not be made out of a single piece of rubber because when pressed all the way down a size-able round gap is left in the middle.

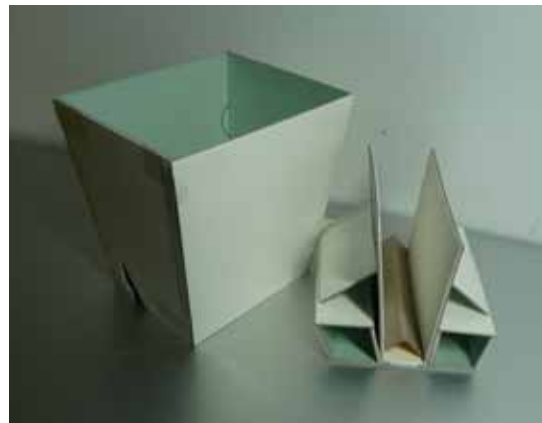

The idea behind this concept was to use two rigid side pieces which when something was pressed down into the middle would cause the two side panels to press in. While it seemed like an interesting idea to use, it would become very complicated as the form itself does not rest in an open state. A spring would need to be used somewhere.

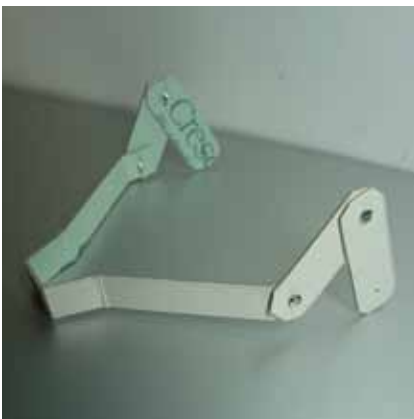

This concept would use nearly the same mechanism as the standard mop wringer but instead of having a handle the mop would be used. The center of the bar catches the handle of the mop and the same motion as the standard wringer could be applied to wring out the mop.

Final Wringer Concept



For my redesign of the mop wringer, I chose to keep the idea of a down force wringing method. This type of wringer is placed near the center of a mop bucket to prevent the bucket from tipping over when the mop is being wrung out.

Unlike its partner on the previous page this wringer has two flat sides in the center which remain rigid allowing more water to be squeezed out. The flat part in the center is to help the mop not get caught in the bottom of a 'V' restricting the wringer from closing all the way.

Resolving Details

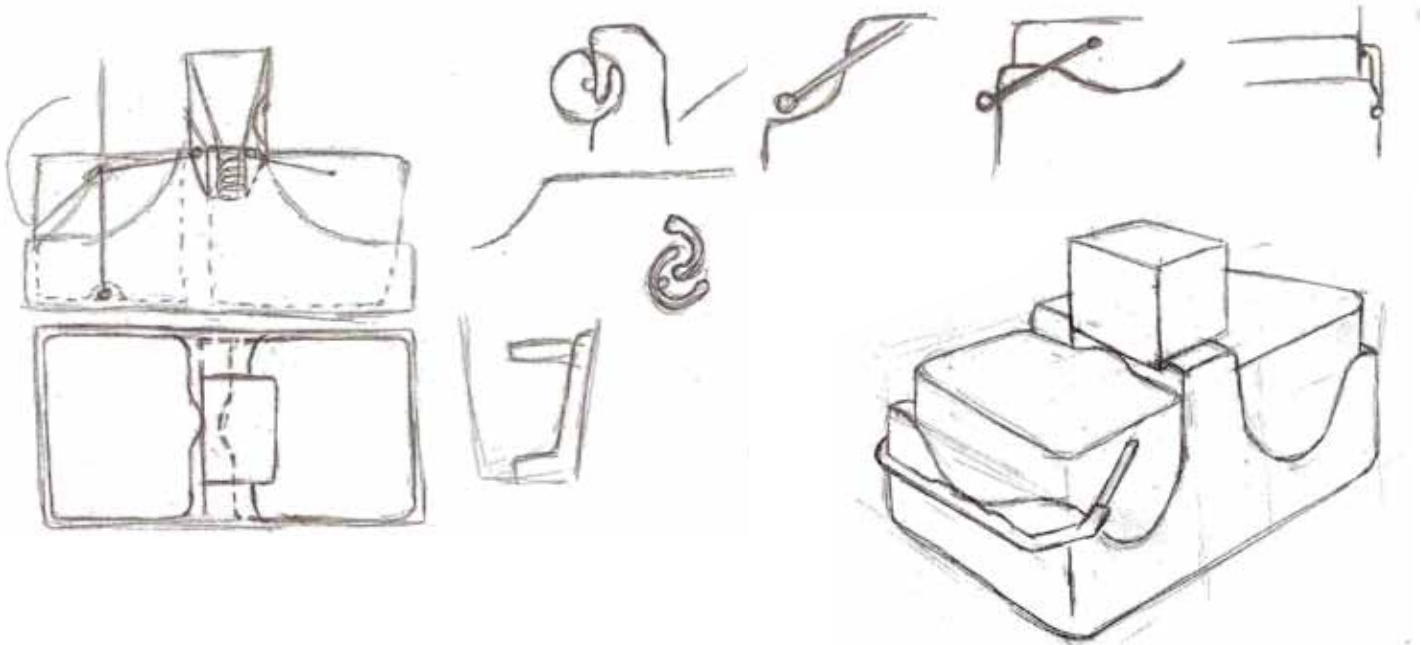

Before being able to continue on the final concept a few issues needed to be resolved. I realized that there needed to be a way to lock the bucket into the chassis otherwise when you pulled on them with the mop it would pull out as well. I thought of a few different ideas, with rotating locks or having the handle clip into the bottom. The it seemed the most efficient way to solve this issue would be to use a simple cam device, like a kickstand that the handle could slide over and lock into place.

The other issue to resolve was how the wringer was going to work with the shape of the buckets. originally I just had the wringer setting on top of the chassis but realized that in order to get the bucket to slide in under it, it would need to be tipped very far and water could spill out. To resolve this issue I decided to fasten the wringer with a hinge that you could move when the buckets are to be emptied.

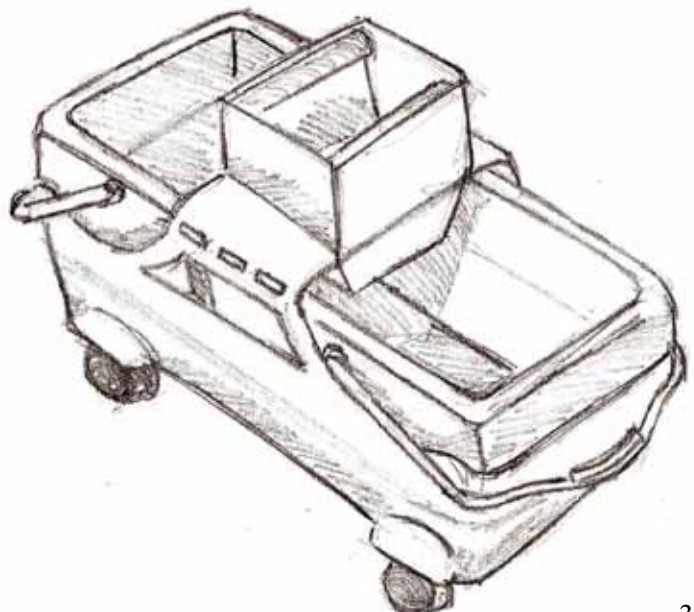

Final Model



Orthographics

Chassis

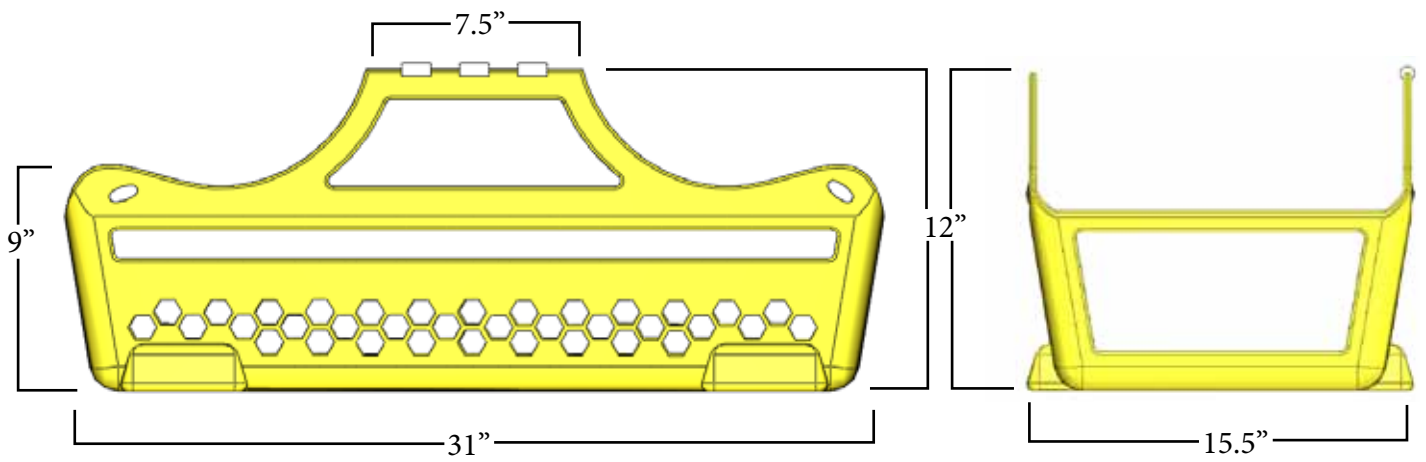
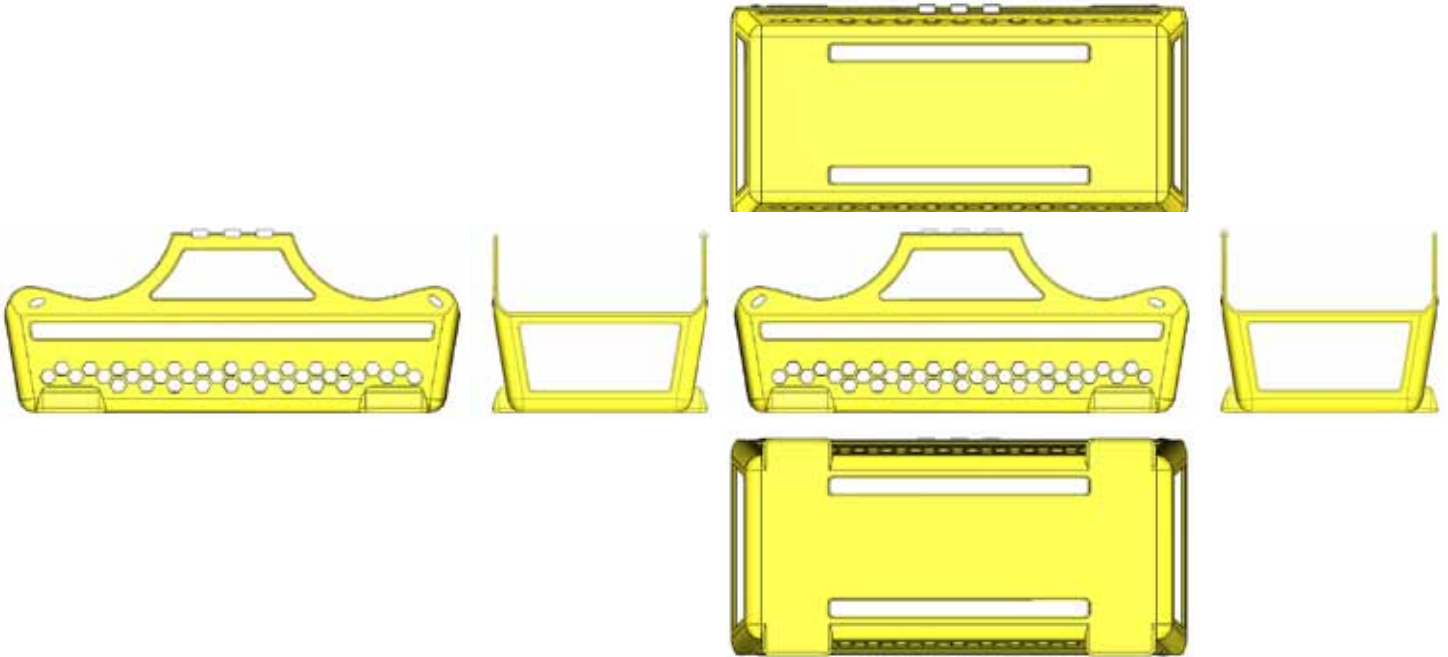

Large Bucket

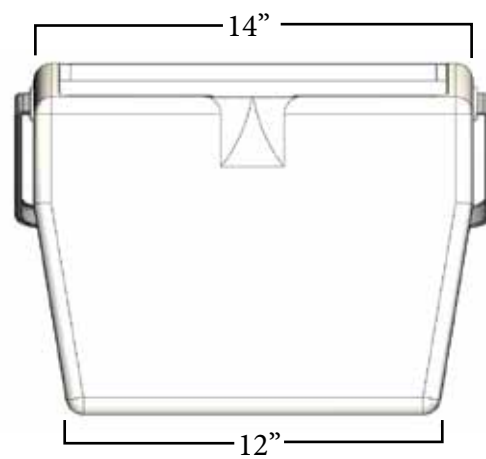
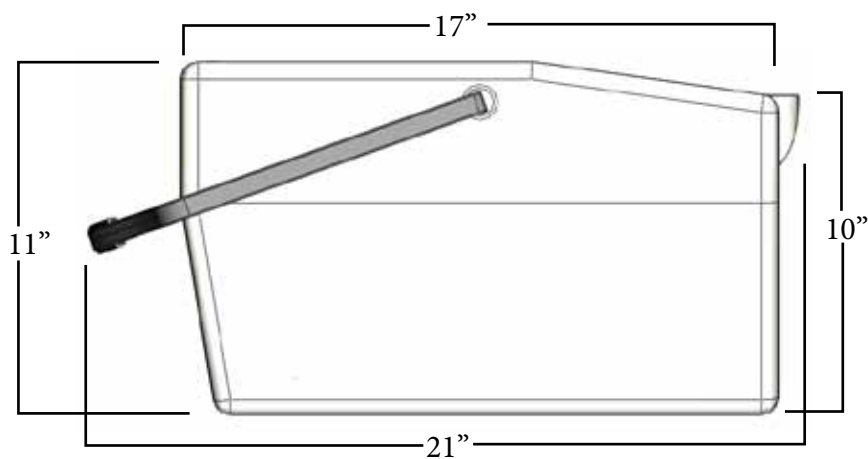
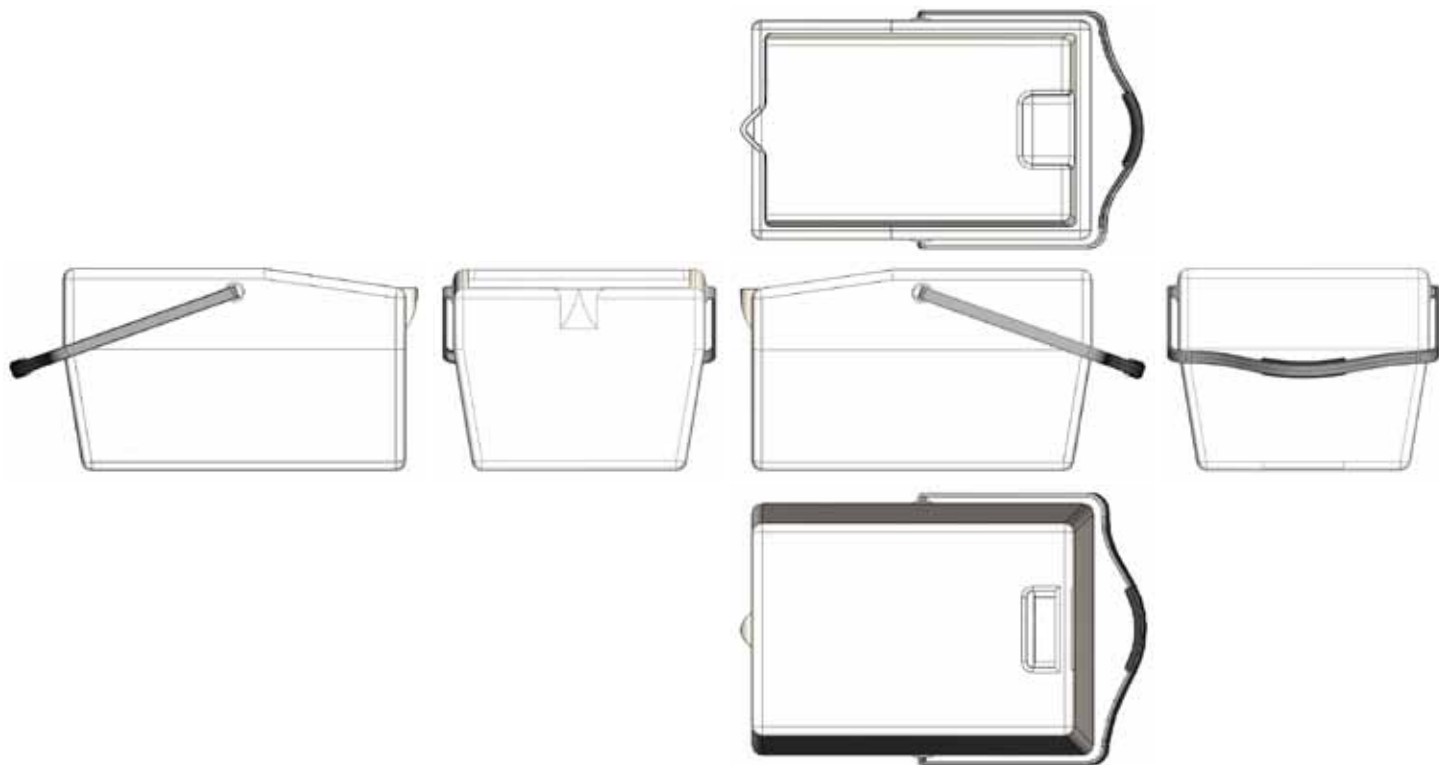

Small Bucket

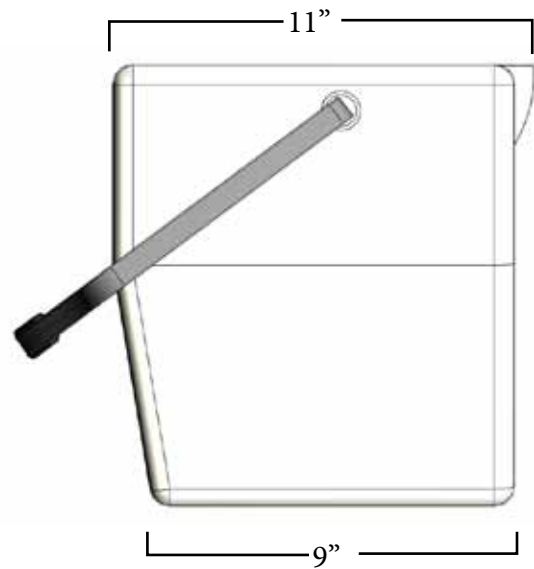
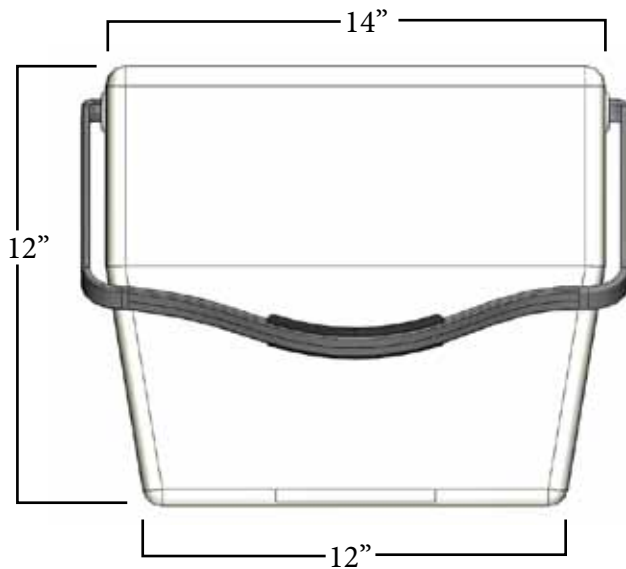
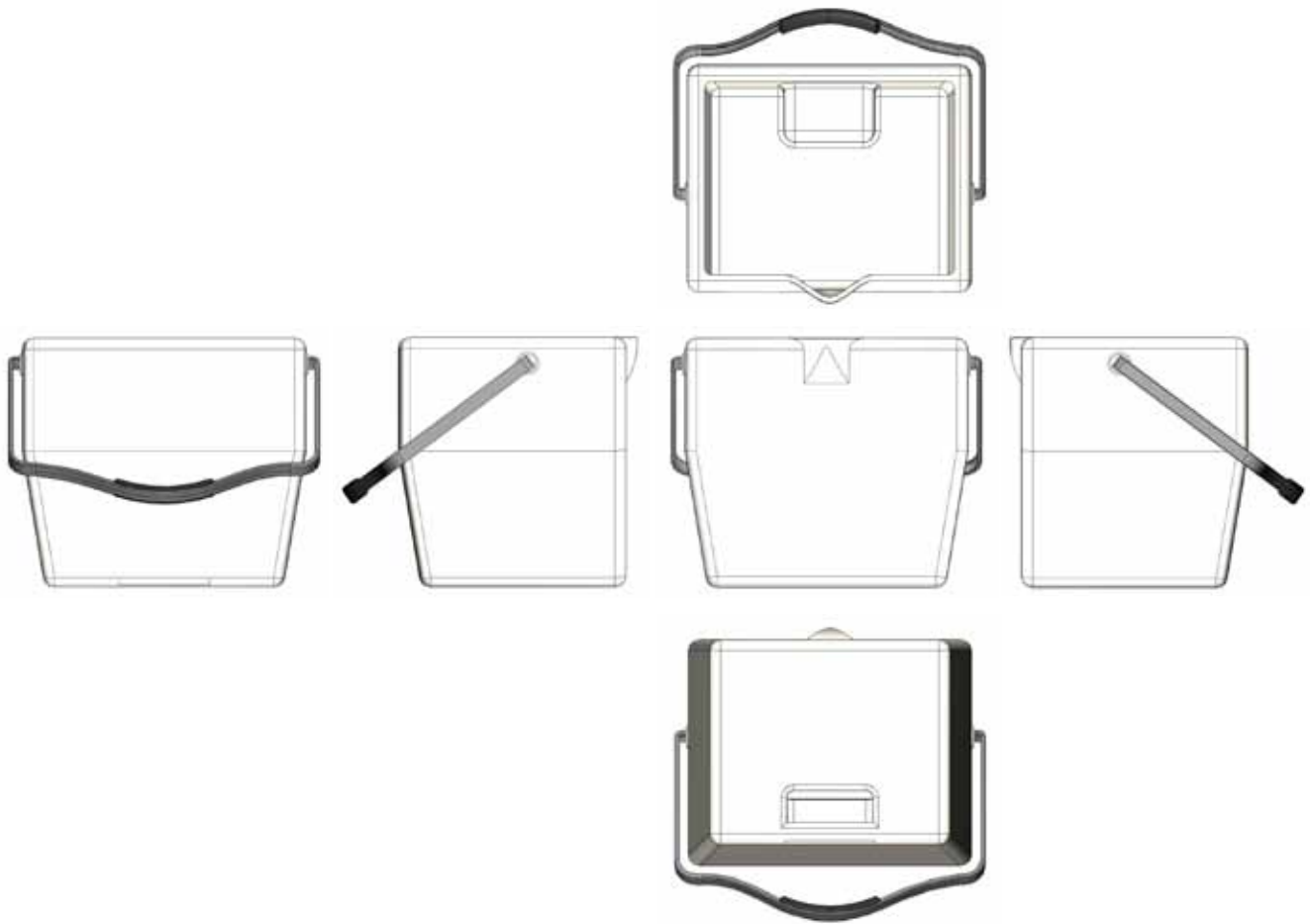

Wringer

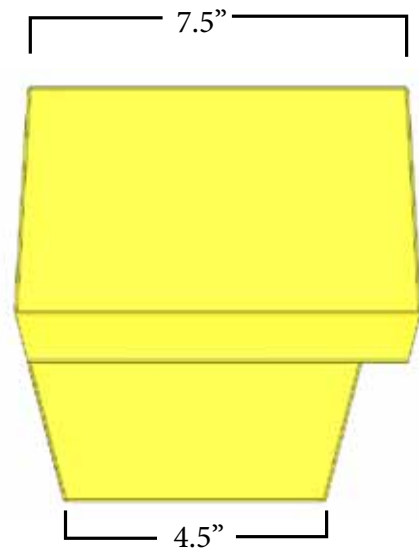
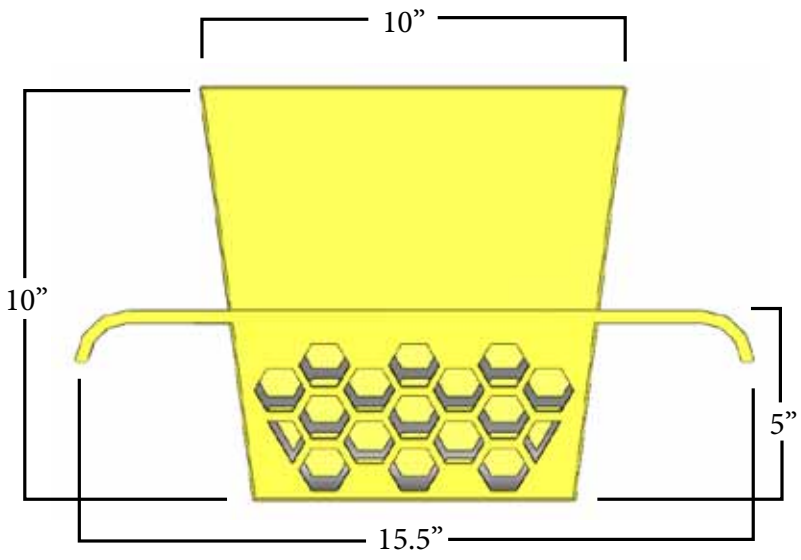
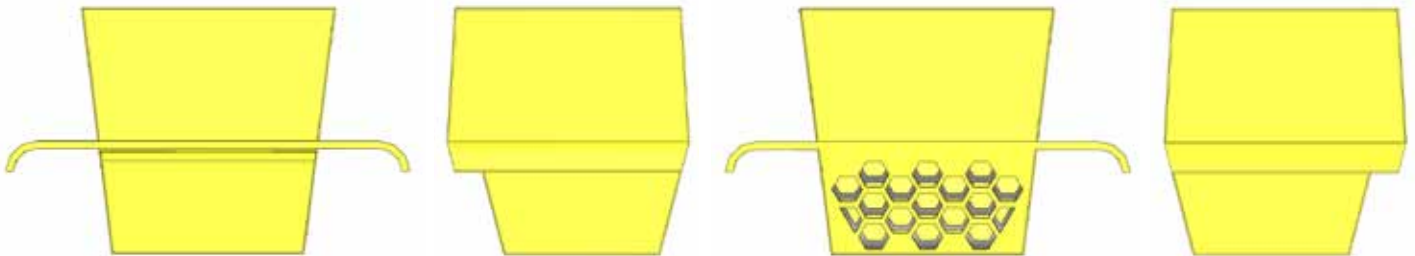

Wringer Concept

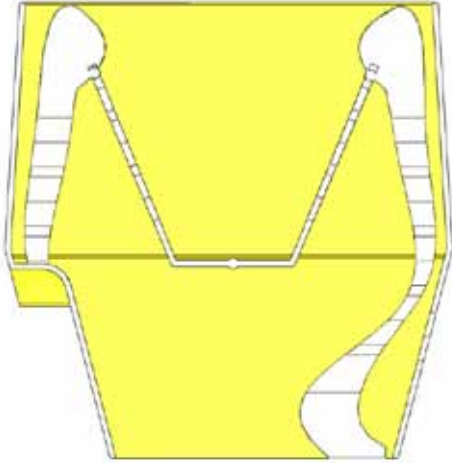

For my redesign of the mop wringer, I chose to use the idea of a down force wringing method. This type of wringer is placed near the center of a mop bucket to prevent the bucket from tipping over when the mop is being wrung out.

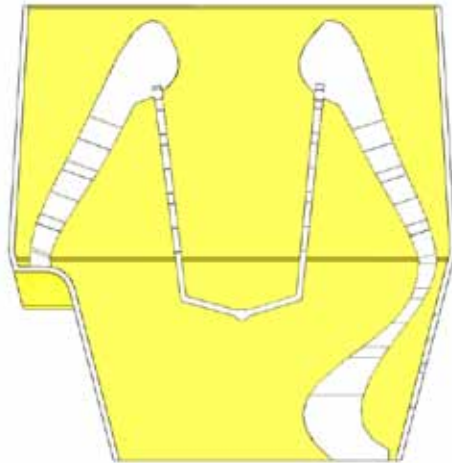

The way this concept works is with a living hinge created from utilizing thicker and thinner sections of rubber. When the mop is pressed into the wringer the thin portions flex and push the top of the wringer shut. This inward collapsing causes the water to squeeze out of the mop without needing a separate handle.

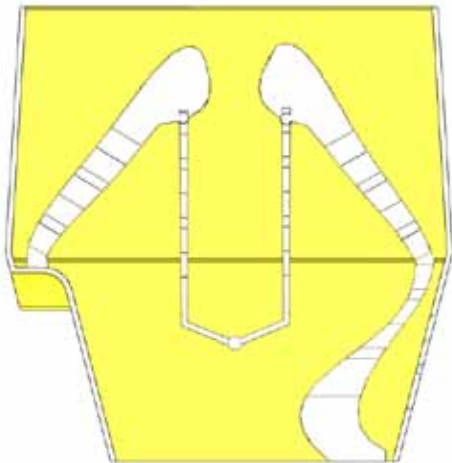

One side of the outer shell is grated to allow water to flow out into the larger of the side buckets. Both sides of the inner wringer are grated allowing more water to flow out. When pressure is released the living hinges pull the wringer back into the open position.

Final Model



3-D Print

3-D Print Process



I decided that a 3-D print could really help visualize my product



Shortly after removing my project from the machine



Pieces scraped off, still needs sanding



Pieces assembled before sanding and gluing

3-D Print Model



I used brass to create the flat handles and added rubber grips to them. Pieces assembled



Components separated

Final Model



Rendering

Human Scale



Final Model

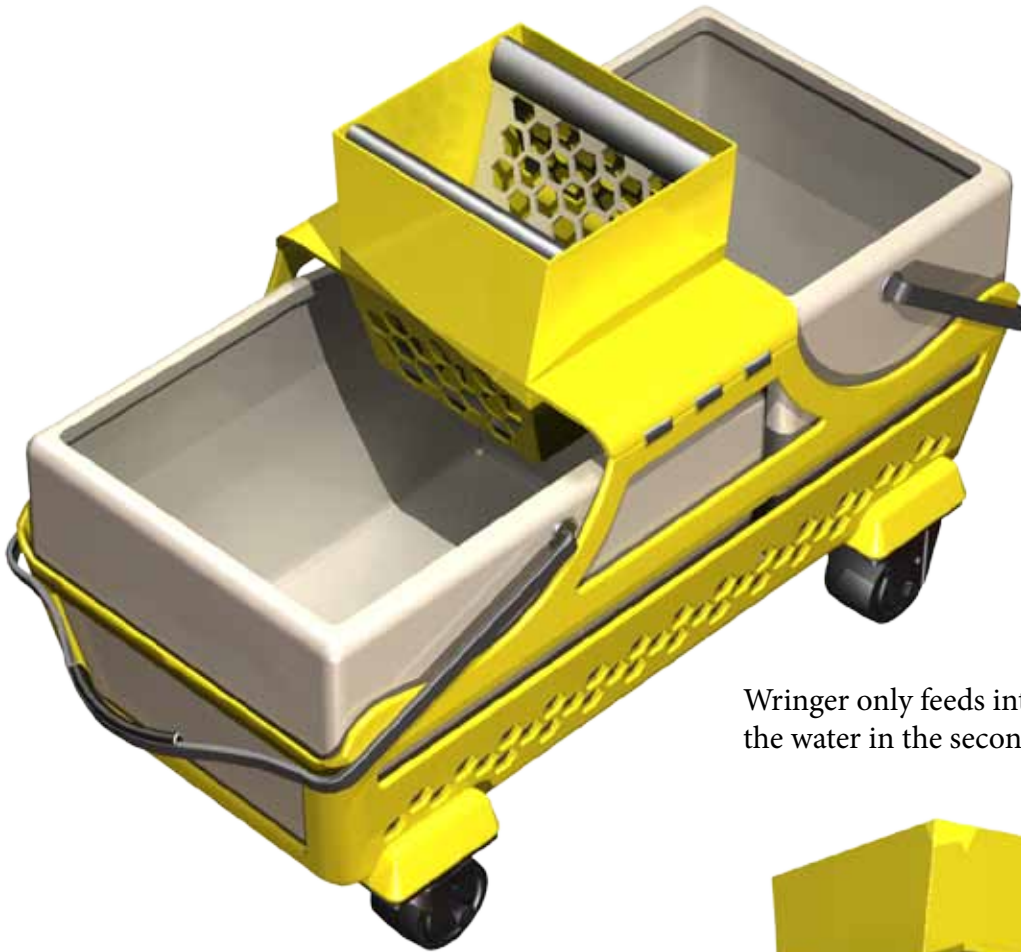

Wringer only feeds into the larger bucket, keeping the water in the second smaller bucket, cleaner.



Model has a pair of fixed wheels and a pair of casters. This helps keep the bucket rolling in the desired direction and keeps the back end from swinging outwards.

Final Model

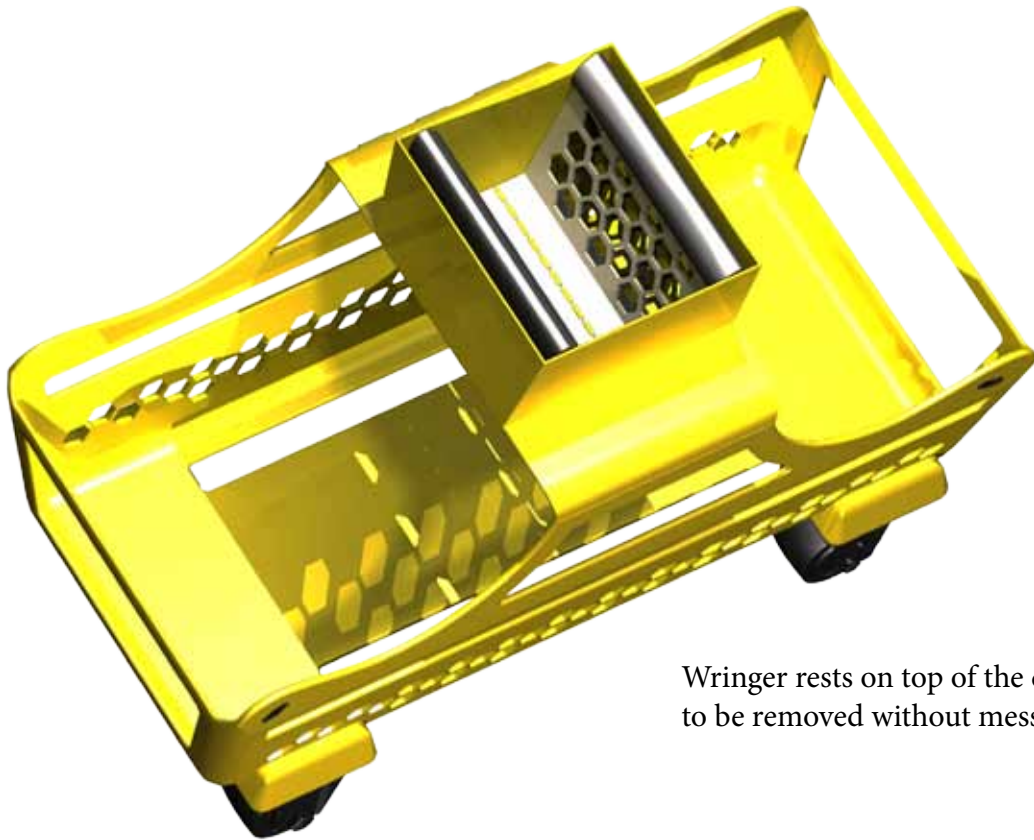

Wringer rests on top of the chassis allowing the buckets to be removed without messing with the wringer.

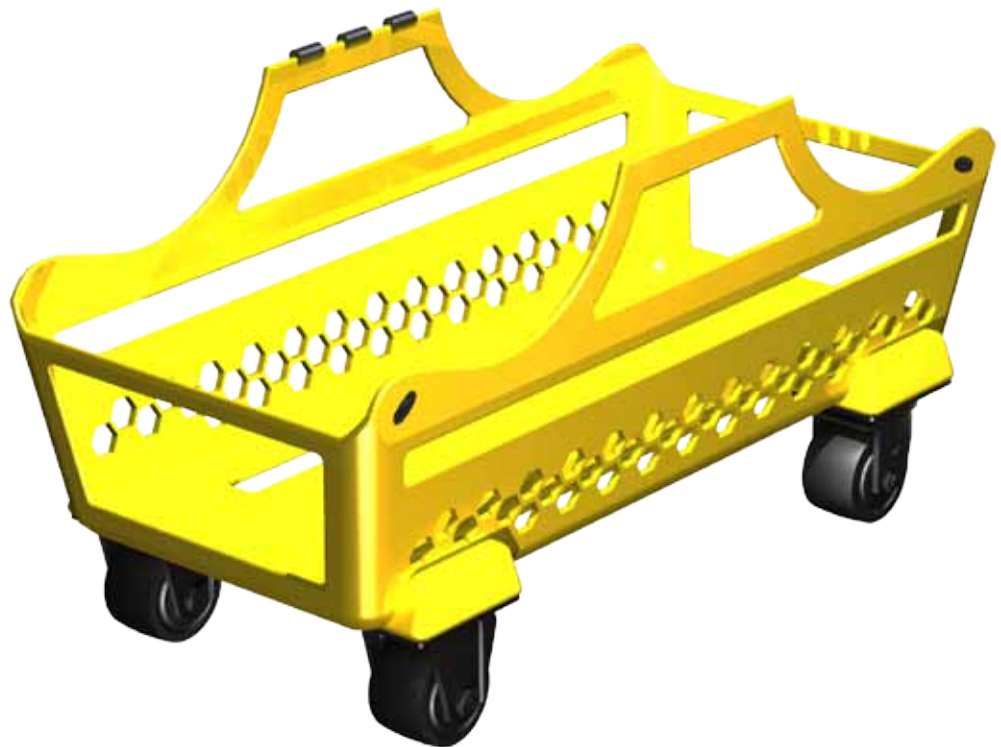

Chassis has small raised ribs on each side which the bucket handles snap onto, helping lock the buckets in place.

Final Model



Both buckets are designed with a thicker handle than most, helping reduce stress on hands when being picked up. Rubberized handle provides for a comfortable grip.

The reversed rolled lip on each bucket catches on any standard mop head and allows the unit to be pulled with the mop itself. The larger of the buckets has a slight angle to the front end keeping the pour spouts from interfering with each other while resting in the chassis.



On the underside of each bucket a molded in hand grip makes emptying the buckets easier. Molded pour spouts help keep the water flowing in the proper direction.

Final Model



Push down wringer eliminates the need for a separate handle allowing everything to be done with only the mop.

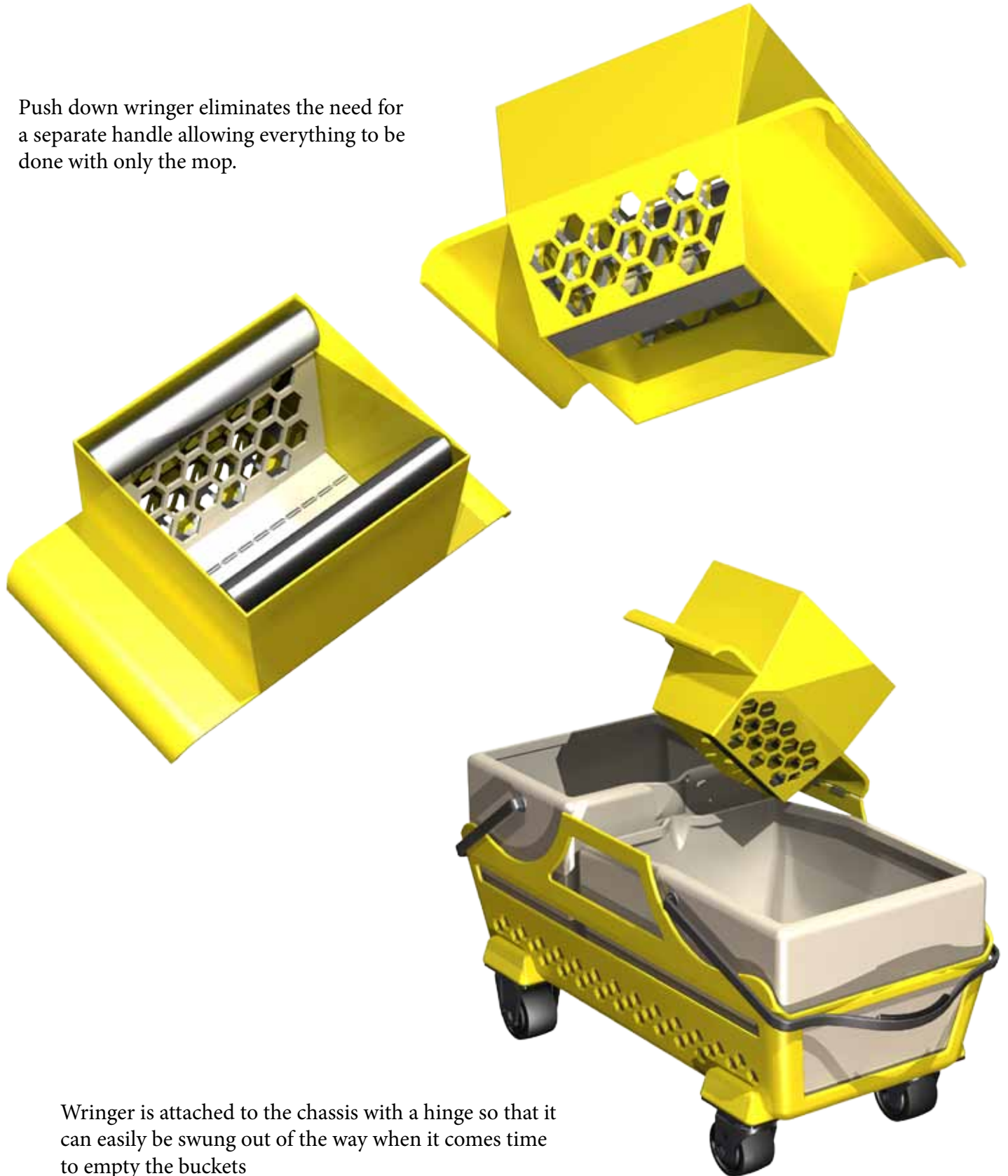

Wringer is attached to the chassis with a hinge so that it can easily be swung out of the way when it comes time to empty the buckets

Final Model



