

DETAIL A  
SCALE 1 : 1

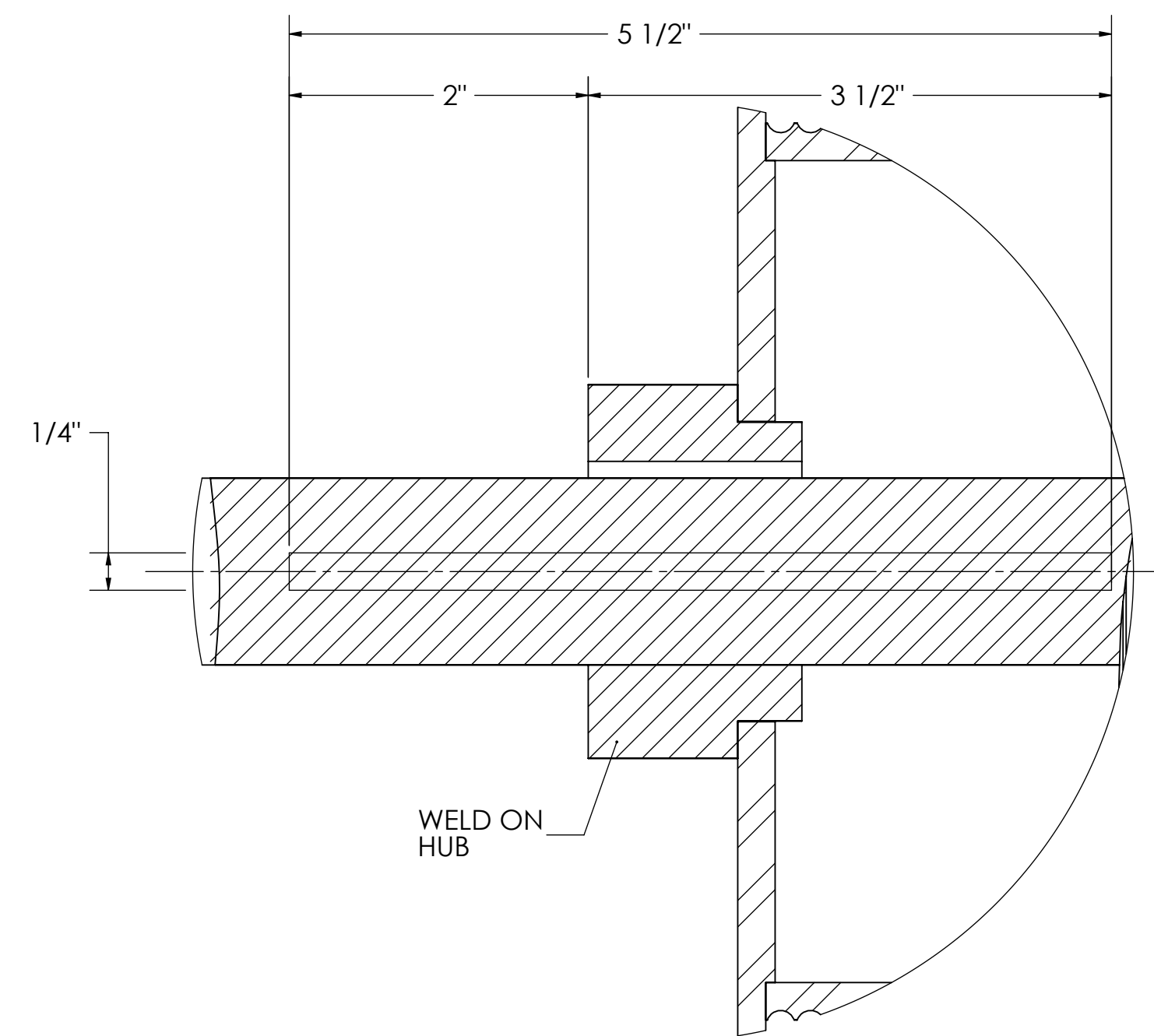

DETAIL B  
SCALE 1 : 1

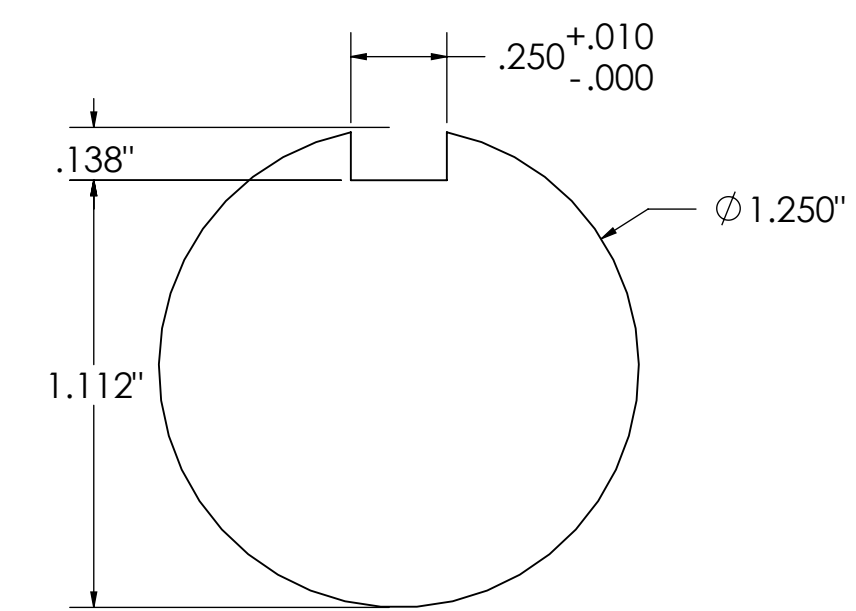

REV 01 DATE

**PERFORMANCE SOLUTIONS**

26 BASIN ST  
TORONTO, ONTARIO  
M4M 2P2  
PHONE 416 461 9600  
FAX 416 461 0770

PROPRIETARY AND CONFIDENTIAL  
THE INFORMATION CONTAINED IN THIS DRAWING IS THE SOLE  
PROPERTY OF PERFORMANCE SOLUTIONS. ANY REPRODUCTION  
IN PART OR AS A WHOLE WITHOUT THE WRITTEN PERMISSION OF  
PERFORMANCE SOLUTIONS IS PROHIBITED.

| NAME                | DATE        |
|---------------------|-------------|
| DRAWN: M. BANNERMAN | JAN 21 2008 |
| CHECKED:            |             |
| ENG APPR.:          |             |
| MFG APPR.:          |             |
| G.A.:               |             |

DWG TITLE:

**DRIVE SHAFT**

JOB TITLE:

**KINGSTON REGIONAL SPORTS AND ENTERTAINMENTS CENTRE**  
WOR# 2531  
#1 Barrack Street, Kingston, ON

SIZE DWG. NO.

**D 08-002-46**

SCALE: 1:4