



"REAL AIR" PROJECT

Target Season: Holiday 2010
 Target Price: \$100
 Summary: Create a "shock" absorption sandal using high-end materials and unique construction.
 Designer: Zac Andrews



DEMOGRAPHIC

Name: Brody
 Age: 25 - 35
 Employment: Executive
 Income: +/- \$200,000 per year
 Background: Enjoys the finer things in life. Uses disposable income for exotic toys. Thrives on social status and seeks attention.

INSPIRATION

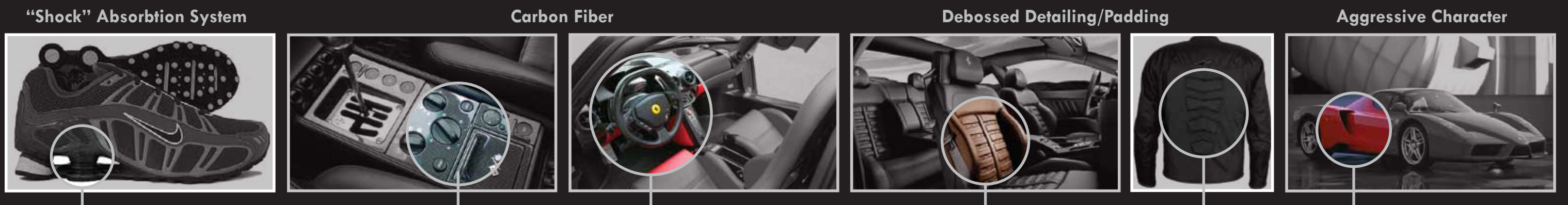

IDEATION

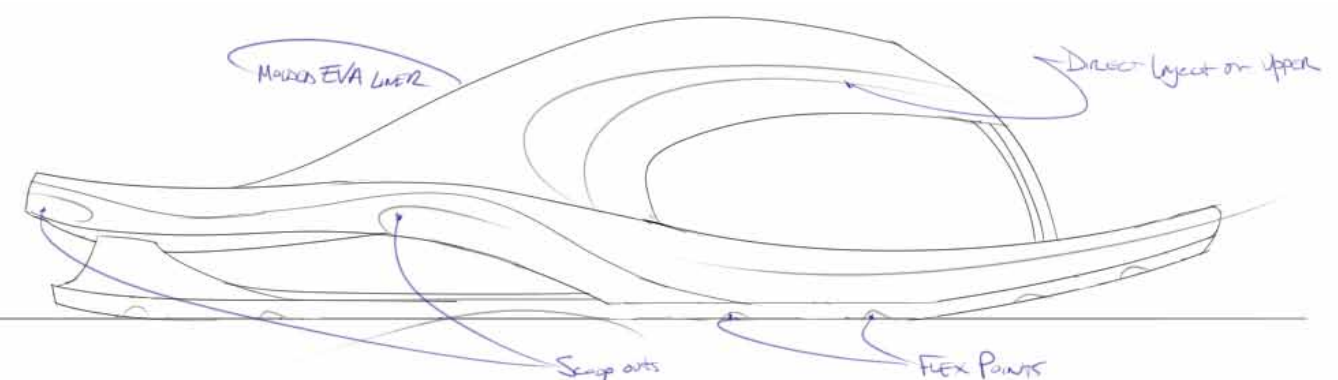
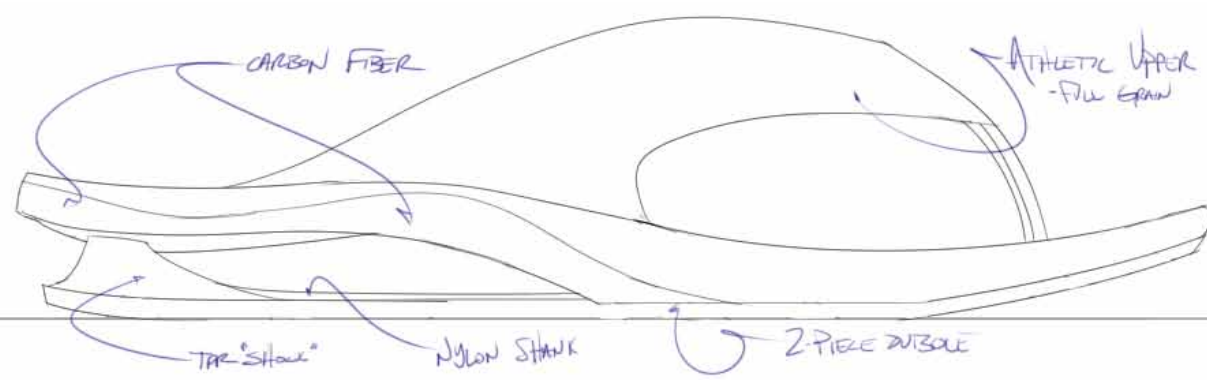
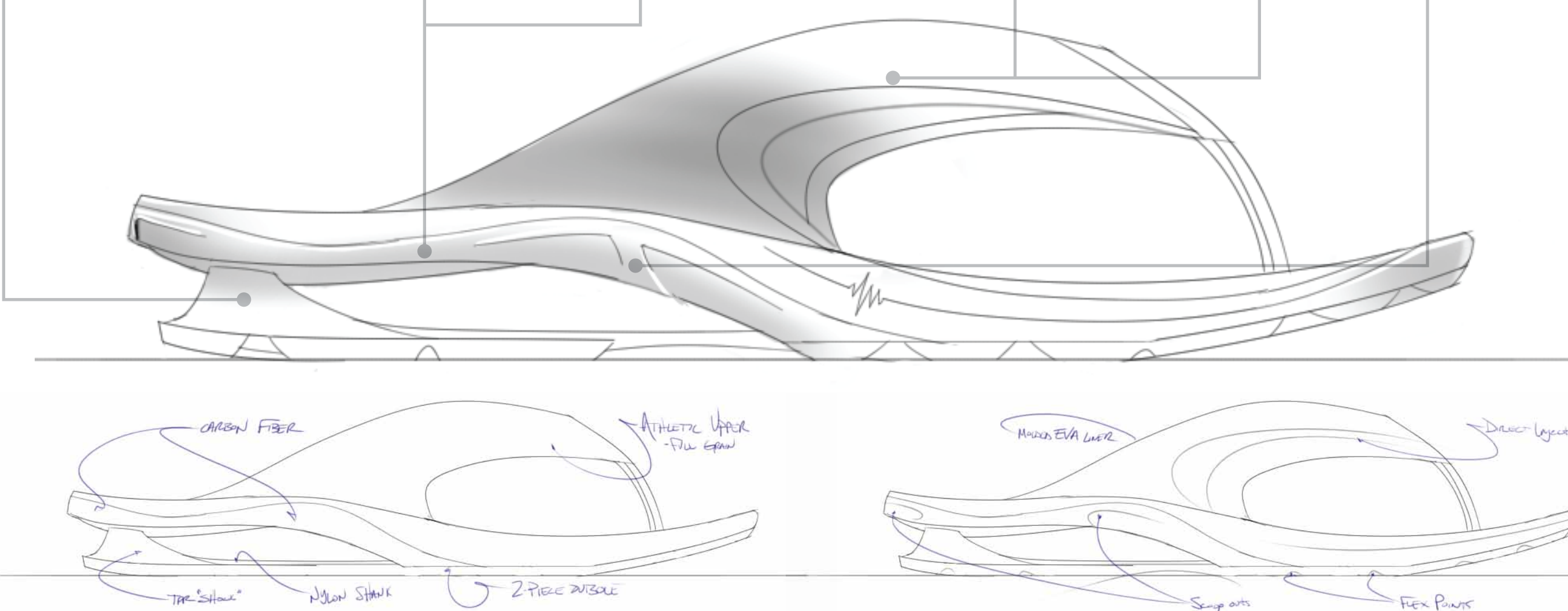

RENDERINGS



TECH DRAWINGS

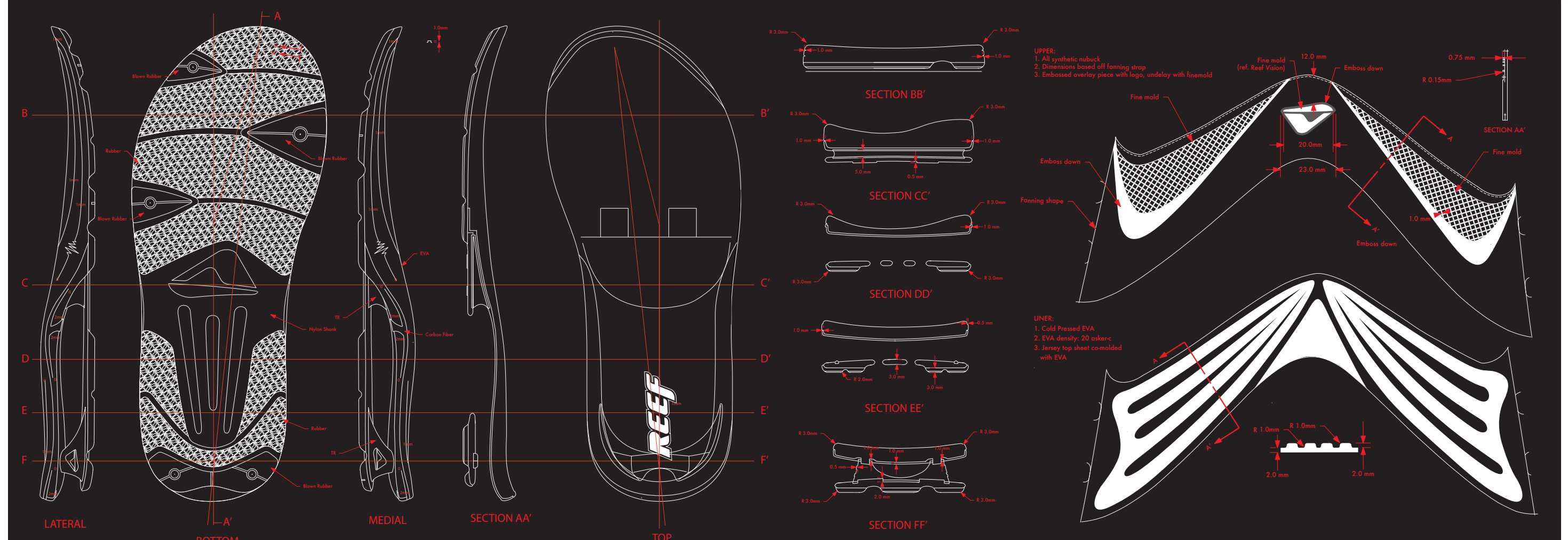

COLOR



REEF "REAL AIR"

