



www.nicolasguzman.com

info@nicolasguzman.com
57 West 8th Street # 2C
New York, NY 10011
tel: 646.436.8185

Portfolio



Furniture

Accessories

Collaborations

Thesis

Others

Furniture

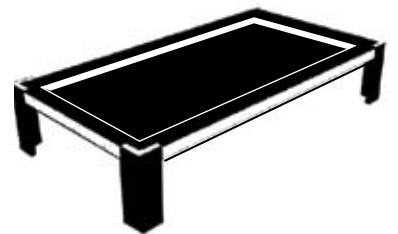
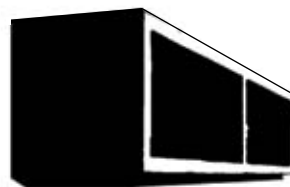
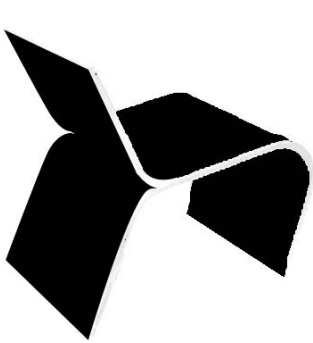

ClaroScuro

Chair Set
Bent Plywood w/ Ebonized Ash Veneer
2005

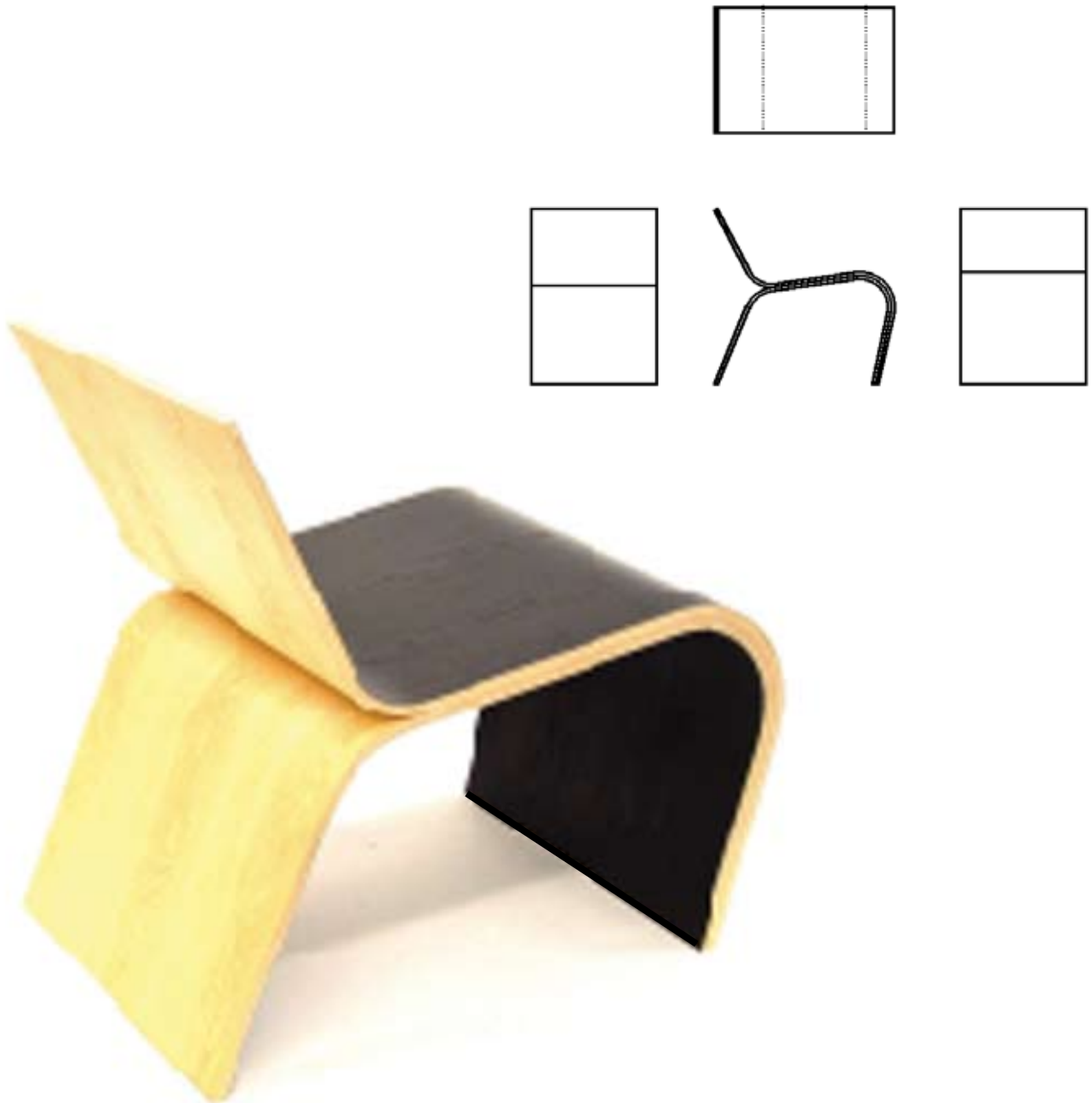

The concept was to create a chair which could be assembled in two pieces but only required one mold. The contrast in the veneer finish emphasizes the process by making it seem as if the material was spreading open in the back.

Auto

Desk Chair
Stainless Steel w/ Cowhide Upholstery
2006

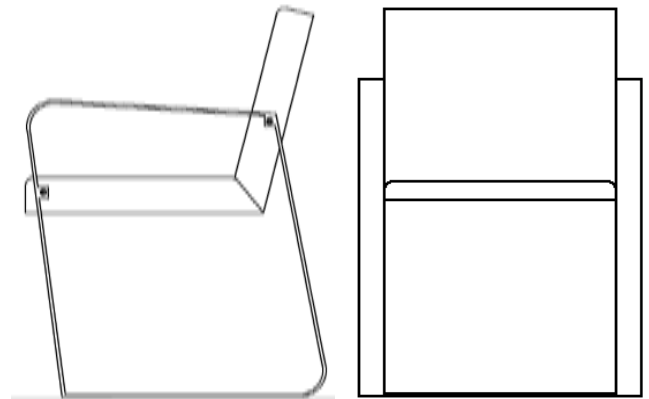

This chair was constructed using car seat elements for support and durability. The idea was to create a sleek piece of furniture that could be related to the origin of the construction materials.

Cajon

Storage Unit
1" Plywood w/ Ebonized Ash Veneer
2004

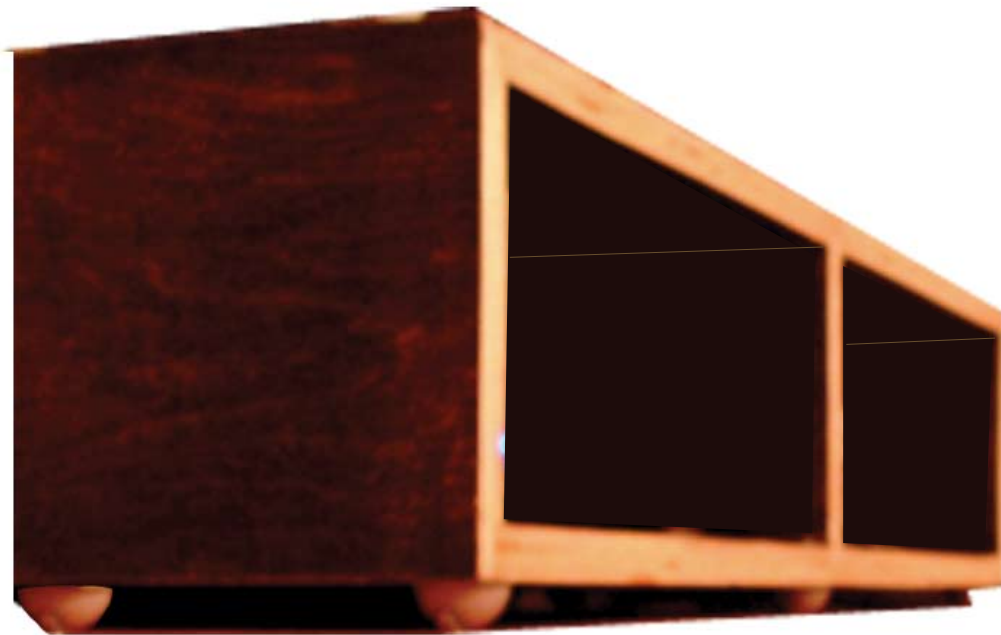
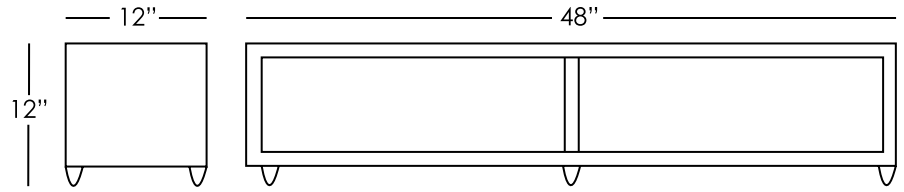

The purpose of this unit is to deliver a simple solution to a space that is often cluttered. The entertainment area.

It comes in modular units which can be stacked for additional storage.

* includes a set of 6 casters.

Marco

Coffe Table
CNC Cut Plywood w/ Steel Laminate
2006

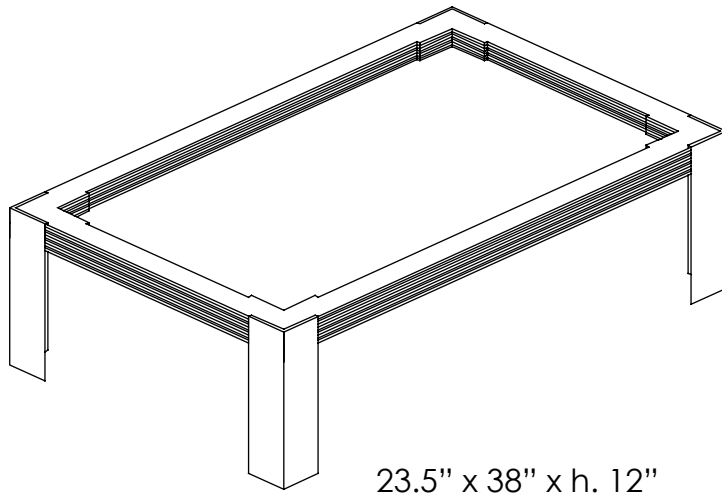

23.5" x 38" x h. 12"

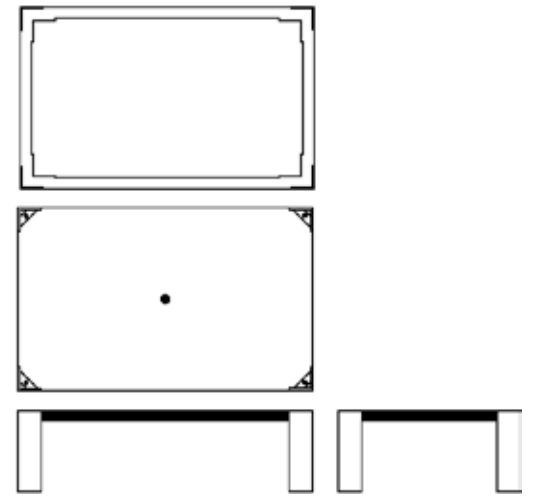

MARCO is a coffee table ready to withstand the wear and tear of everyday use.

The frame around the top provides support for the legs while the inner tray is shallower for reduced weight and a contrast in color. Thick and tough yet sleek and refined.

Accessories

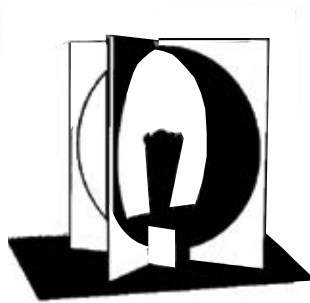

Espresso

Coffee Cups
Porcelain
2005



Its shape may appear simple, but it is actually quite technically sophisticated. In fact, it was especially conceived for the consumption of espresso.

As the coffee is poured, the rounded cup causes the espresso foam to rise up along its edges. This guarantees a cup of coffee with just the right amount of foam.

Sal y Pimienta

Salt and Pepper Shakers
Sterling Silver w/ walnut caps
2004



Handmade from Sterling Silver, these Salt and Pepper Shakers were created as an exercise that aimed to speak quietly from a design perspective but that could have a strong presence and a timeless feel.



Based on the concept of reuse and over consumption, the idea here was to find a common household product and give it a new life.

Recontextualizing the use of something while at the same time borrowing the form from an obsolete item. This in turn is cost effective, sustainable and shows how simple can sometimes be better.



A combination of three items.

A Flower Vase
An Incense Holder
A Tea Light Holder

The space created by the 2 layers of plastic serves as a frame for the object in use.



The desk space...

Sometimes we need nature in a space where stress can take over.

The plant brings color and life to a an object that is seldom considered as relaxing or beautiful.

Collaborations

H₂O_RGANIZE

MAGIC BOX

rollio



Little Houses on
the Black River

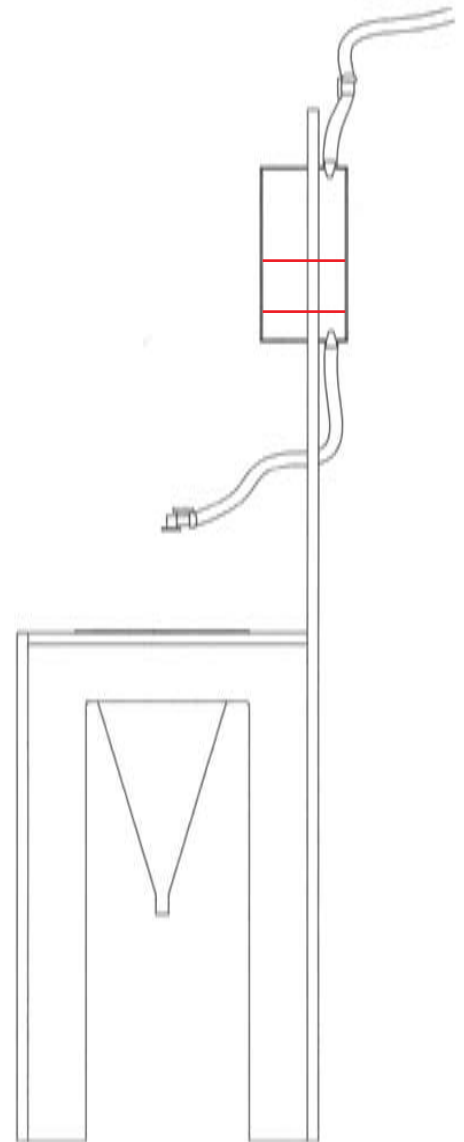

The purpose was to develop a system that is commonly used in everyday life. The objective was to make the user interpret it in a different way.

The solution was a water pumping system which had a set of marks which indicated the user how much water was being used. It also allows the user to fill the tank before it's use. This would in turn save water and inform at the same time.

The idea of seeing the water flow also adds value to the action and raises the levels of engagement between the user and the object.

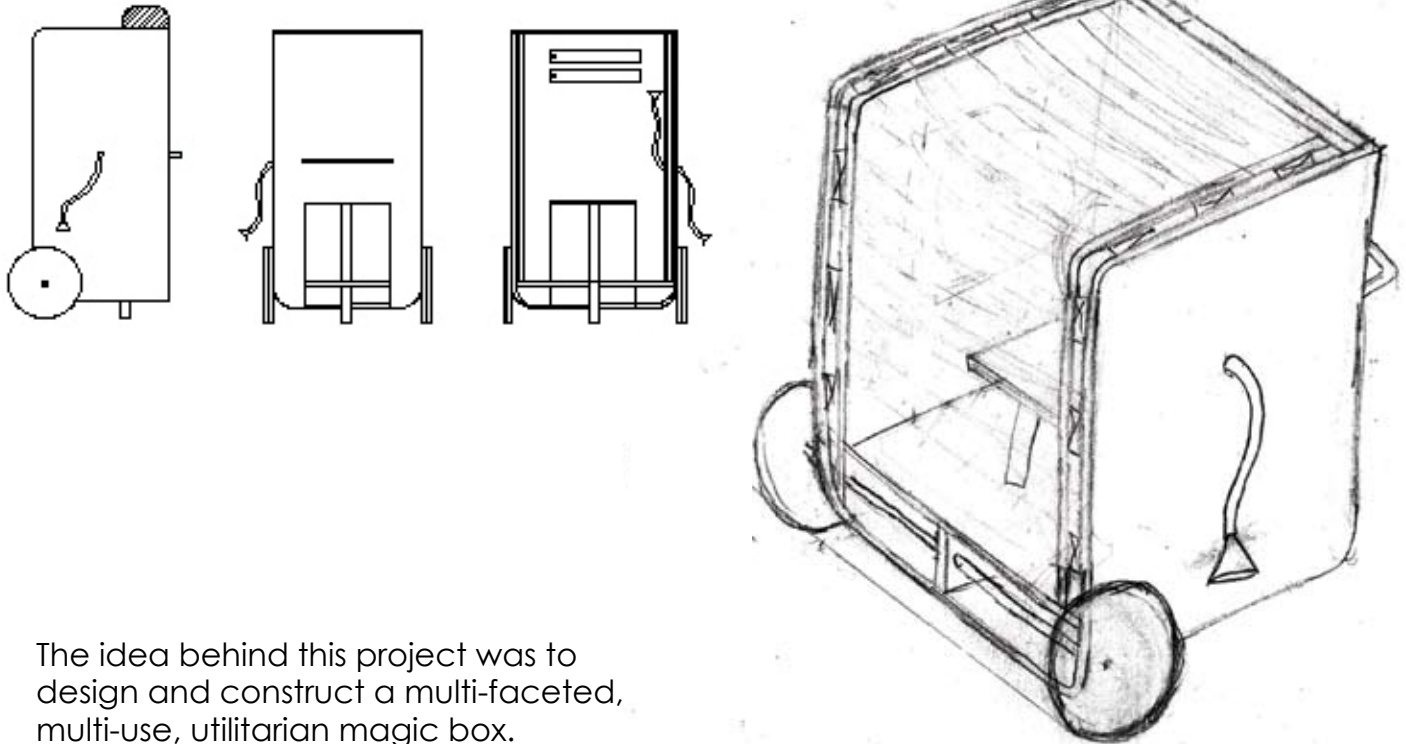

The idea behind this project was to design and construct a multi-faceted, multi-use, utilitarian magic box.

The requirements for this project were the following:

- Carry weight of at least 200 lbs
- Include Casters or wheels
- Doors with hinges
- Must Include Upholstery
- Ornament on the surface

The result was a booth which could be moved around with a handle like a trailer. When closed it can be locked and the idea is to have interaction between the interior and exterior, only through a funnel. This creates a feeling of uncertainty for the user making it a unique experience.

roll'o

Utility Knife
Ergonomic Exercise
2003

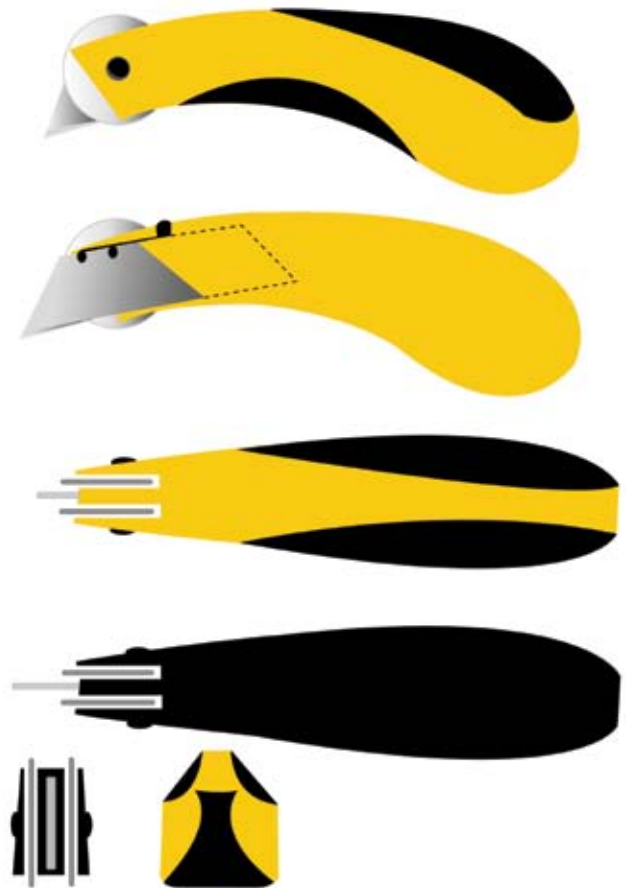
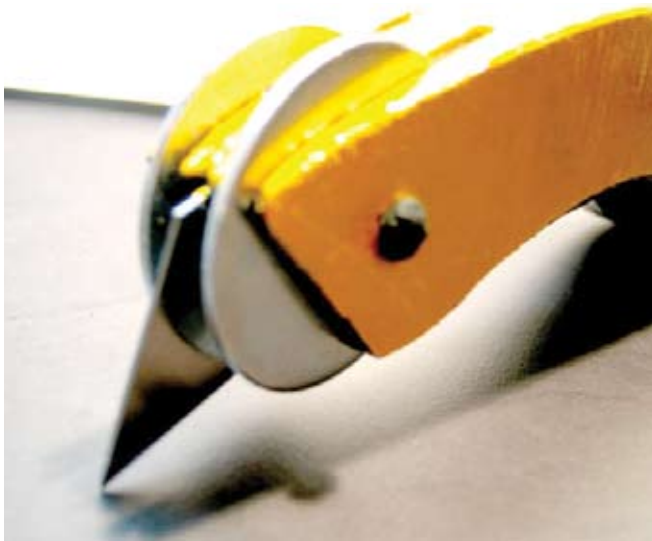

Roll'o is a an attempt to approach the box cutter in a different way.

The objective of this exercise was to consider ergonomics and the way the tool was used.

The blade is surrounded by a wheel which allows for a steady grip when cutting straight. The wheel also helps the blade glide over the material without damaging the box. Finally, the grip is very light making it easier on the hand after repetitive use.

Little Houses on the Black River

Parsons Junior Seminar
Hallefors, Sweden
2006

This was a one year collaboration between three international schools. Parsons from New York, Konstfack from Sweden, and St Etienne from France.

The concept was to develop three modular dwellings and approach architecture and construction from a furniture design perspective.

The solution was a panel system that was easy to manufacture, ship and assemble. The interior of the house is based on a cleat system that not only allows for endless combinations inside but it also serves as a structural purpose.

The dwellings were built on site in Hallefors, Sweden over a period of two weeks.

Little Houses

On the BLACK RIVER



PLAN OF THE PARSONS
HALF OF THE STRUCTURE



SOUTH



EAST

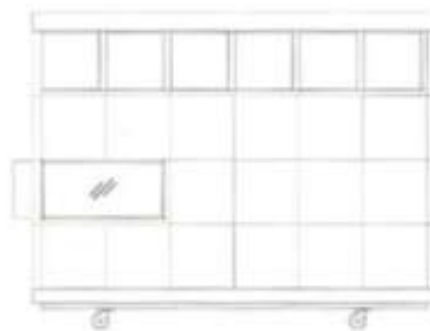

NORTH



WEST



**STUDENTS FROM THREE
SCHOOLS CREATED A
LOW-TECH SUMMERHOUSE
THAT LOOKS MORE LIKE A
PIECE OF FURNITURE THAN
A SEASONAL RESIDENCE.**

**TEXT CATHY LANG HO
PHOTOS ÅKE E:SON LINDMAN**

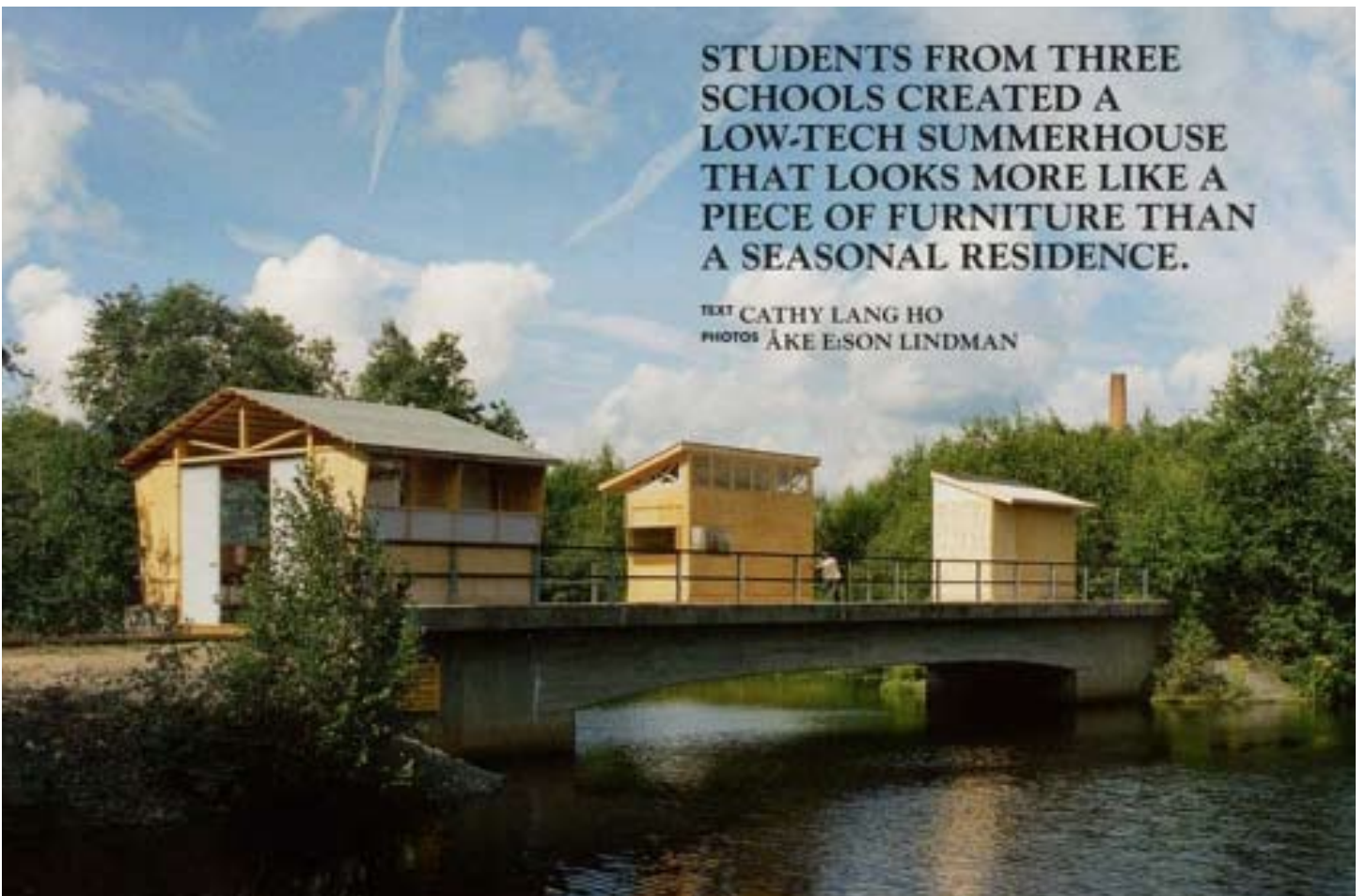









REHAB

NICOLAS GUZMAN | PRODUCT DESIGN THESIS | 2007

A family of furniture pieces made from a blend of salvaged & new materials.

Produced in Collaboration with: **Build it Green! NYC.**

NYC's only non for profit retail outlet for salvaged and surplus materials.



MARGOT

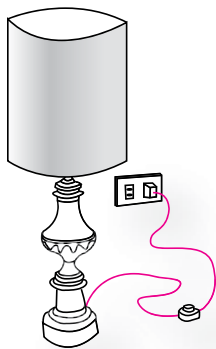

LOLA

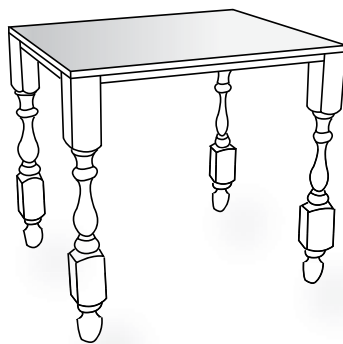

JUANA

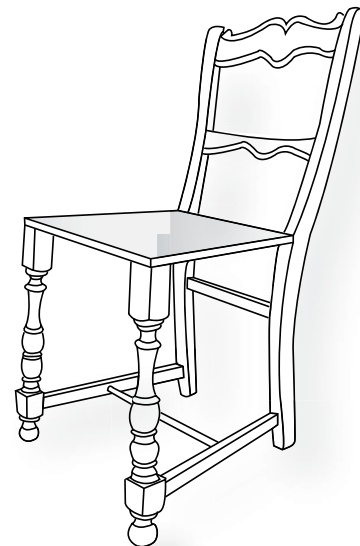

BERTA

Magnets are used as joinery to create a narrative and a meeting point between past and present. This system makes the pieces easy to assemble, allows them to flat pack, and shows how old and new come together to create something special.

The project also raises awareness for disposal alternatives, encouraging individuals to act locally and think globally when it comes to finding ways to divert waste from landfills.



1. Encourages consumers to look twice at their own garbage.
2. Raises \$ for "BUILD IT GREEN! NYC" through 10% of it's profits.
3. Repurposes components that would otherwise be discarded.
4. Are all unique like you & me, so everyone has a name.
5. Are made from a blend of salvaged + new materials.

reusing material makes sense from an environmental, social, and economic point of view.

name tag *



* materials

16 gauge steel sheet

1/2" baltic birch plywood

1" magnetic joint

salvaged material

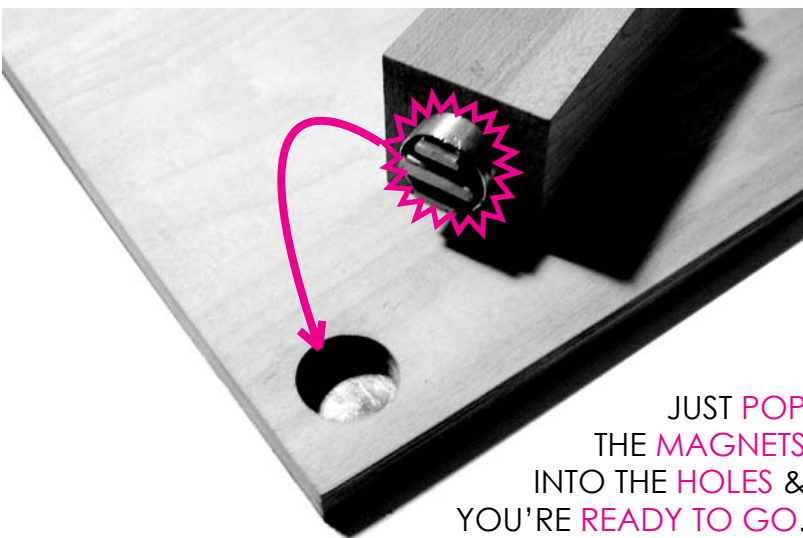
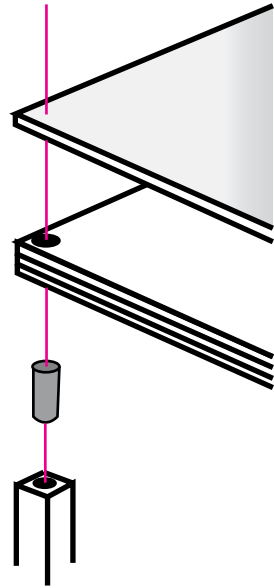

JUST POP
THE MAGNETS
INTO THE HOLES &
YOU'RE READY TO GO.



1" Diameter
ceramic magnet
max. pull 50 lbs.

Multiple & adaptable support and top combinations with use of magnetic joinery.

Others

Models

Renderings

Visual

Documents

Alvar Aalto
(Bent Plywood) Chair Model
1:4 Scale



Gerritt Rietveld
(Joinery) Table Model
3:8 Scale



Framed Structure Exercise
(Bent Tubing) Chair Model
1:4 Scale



Renderings

Alias
Solidworks
2005 - 2006

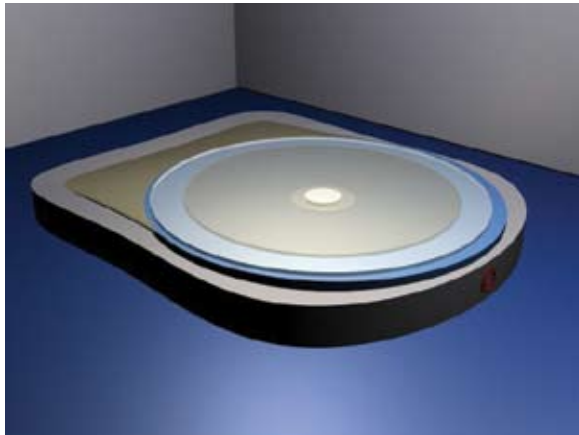

un mp3



mouse



marco table



guitarra

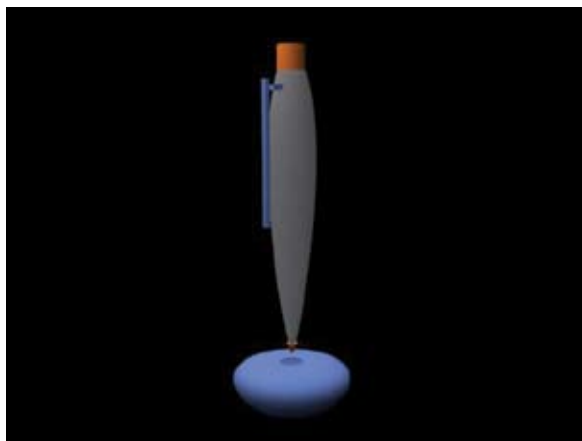

stilo



face shield

Visual

JET
Acrylic on Canvas
2003



18" x 18"

Visual

TORO
Silkscreen on Stainless Steel
2004



17" x 13"

Visual

BURBUJAS
Acrylic on Print
2001



12" x 12"

DESARROLLO SOSTENIBLE

UNA NECESIDAD, UNA OBLIGACION, UNA OPORTUNIDAD Y UN COMPROMISO POLITICO.



The goal was to develop a well-rounded report on the subject of sustainability, and to deliver a package, which could be helpful for Colombian entrepreneurs by making them aware of this global trend. The subject could be of great interest for future investment ideas.

The research stage included several stages: Secondary sources such as governmental agencies and local libraries were visited first to collect preliminary information on the subject. Later the findings were thoroughly documented.

Finally a questionnaire was developed and visits were made to different local manufacturers & retailers in means to learn to what degree the local market is shifting towards sustainability.

The End.

Hope you enjoyed & thank you for your time.
