

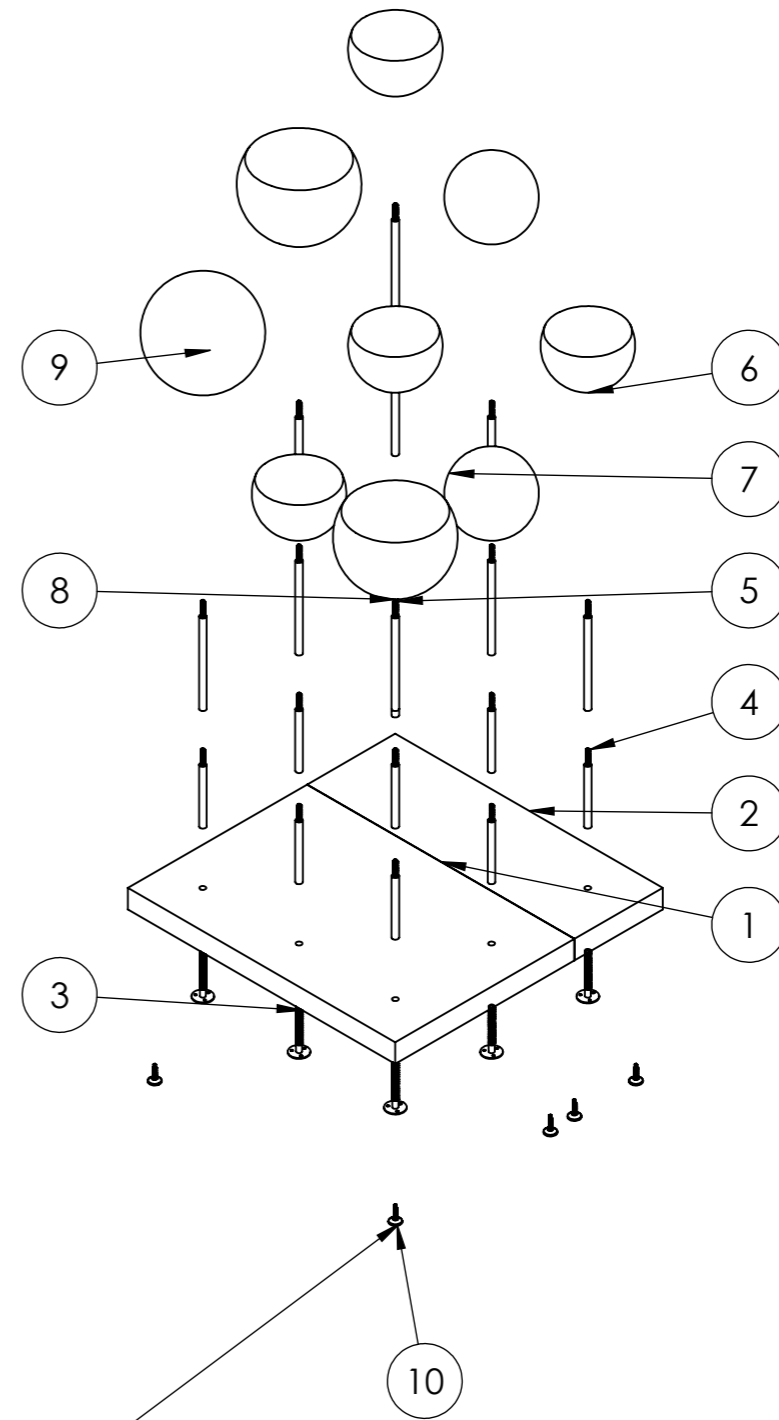

UNIT CAN BE CONFIGURED AS A SQUARE OR SPLIT INTO 2 SMALLER MODULES

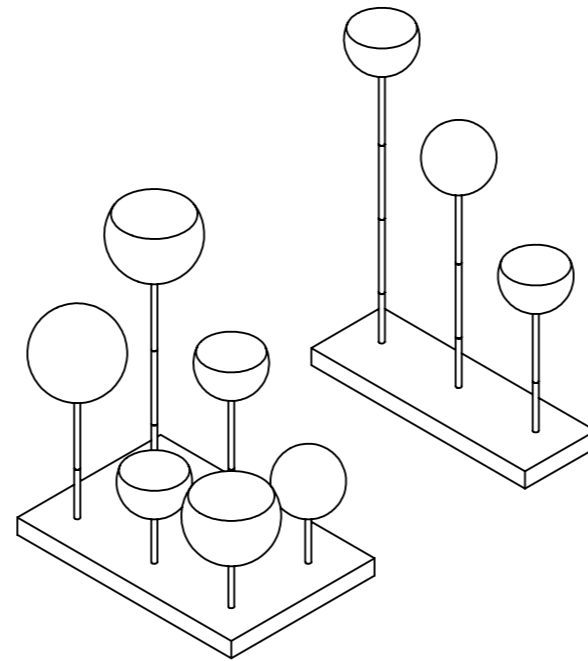

6 NO. M8 SCREW ADJUSTABLE FEET

SPUN METAL/ACRYLIC FULL DOMES AND 3/4 DOMES

BRUSHED STAINLESS STEEL TUBE SUPPORTS

NOTES		
*		
WEIGHT		
*		
ASSEMBLY PART LIST		
PART NO	REV	DATE
001	*	*
002	*	*
003	*	*
004	*	*
005	*	*
006	*	*
007	*	*
008	*	*
009	*	*
010	*	*
*	*	*
*	*	*
*	*	*
*	*	*
*	*	*
*	*	*
*	*	*
*	*	*
		
CLIENT		
LOGO 69		
PROJECT DETAILS		
VM SHOE DISPLAY		
DRAWING TITLE		
VM SHOE DISPLAY ASSEMBLY		
DRAWN BY	DATE	
*	15/07/10	
PART NO	SCALE	
L69-VMSD-00A	* @A3	
DWG NO	REVISION	
L69-VMSD-00A	*	

25mm BIRCH PLYWOOD/MDF

18mm CLEARANCE HOLES TO ACCEPT 16mm THREADED SPIGOT

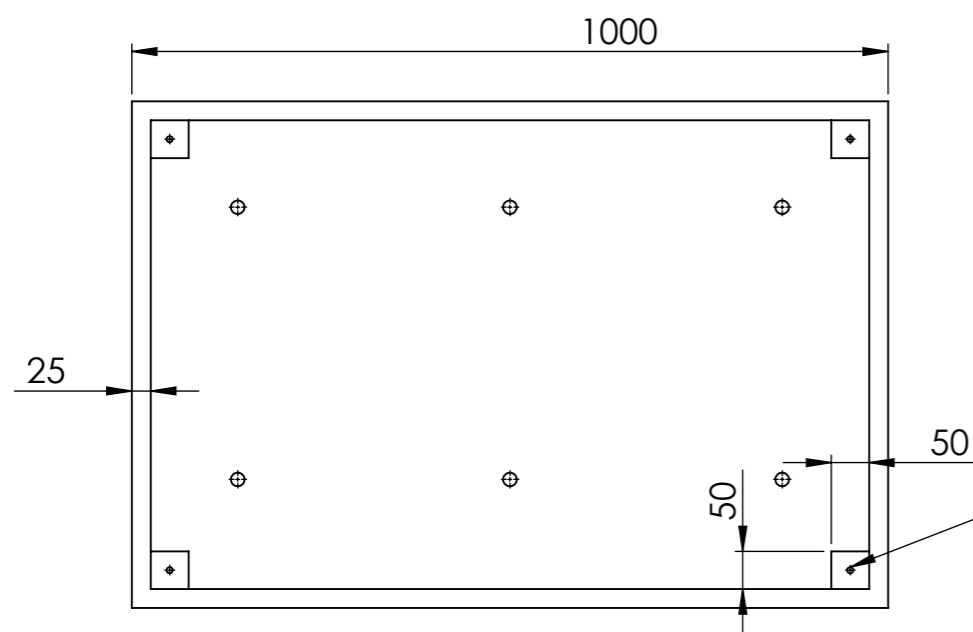
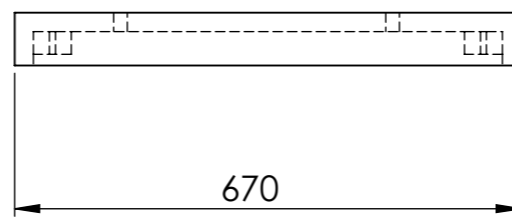
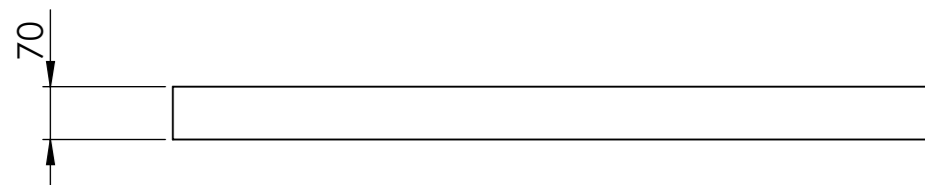
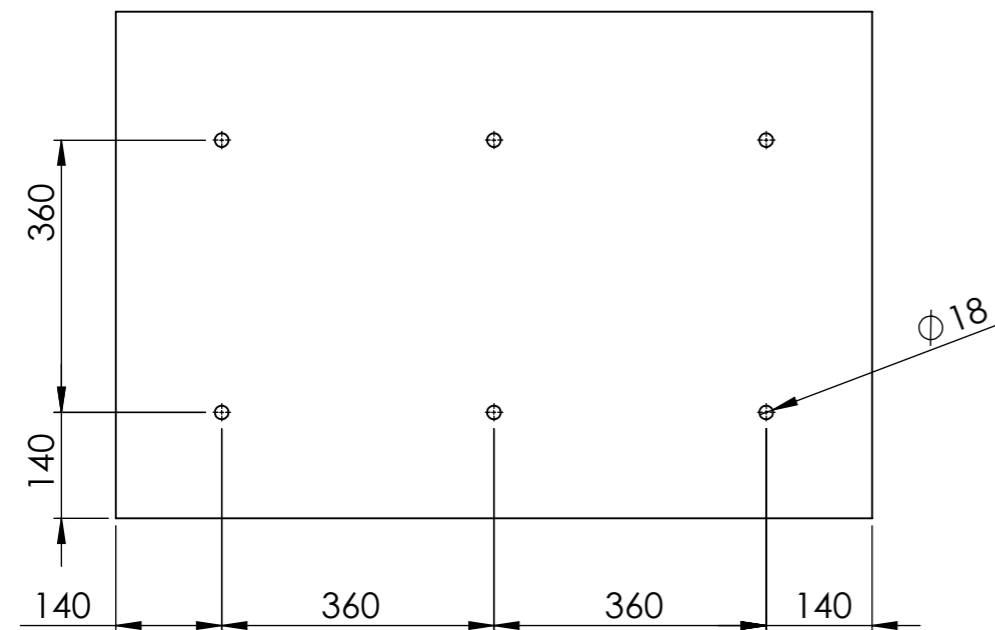
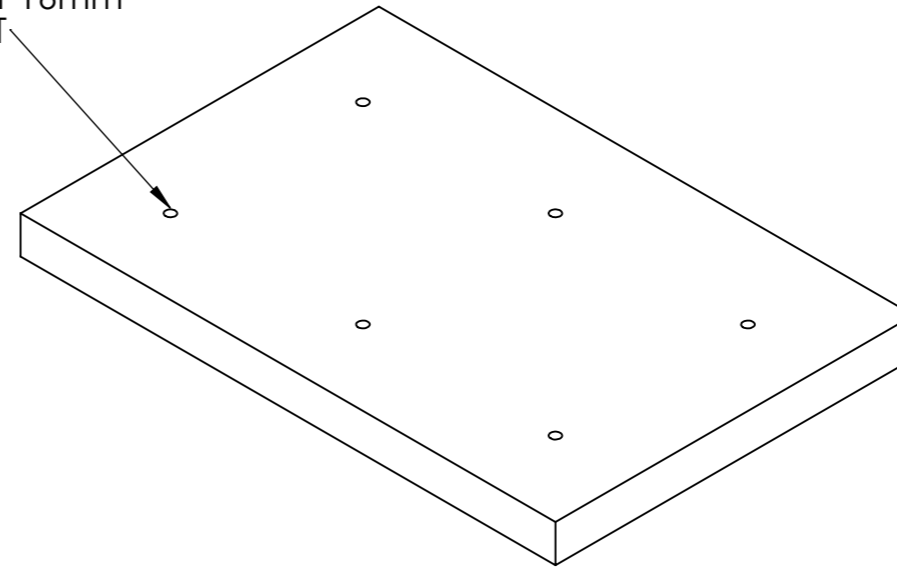

SOFTWOOD BLOCKS WITH M8 THREADED INSERTS TO TAKE SCREW ADJUSTABLE FEET

FINISH: CORAL 162C, FOR APPLICATION SEE NOTES

NOTES

FINISH OPTIONS-

- BIRCH PLY WITH WASHED PMS 162C CORAL
- MDF PAINTED PANEL MATTE FINISH PMS 162C CORAL

MATERIAL

25mm MDF/BIRCH PLYWOOD

FINISH

SEE NOTES

WEIGHT

*

REVISIONS

REV	DETAILS	BY	DATE
*	*	*	*



CLIENT

LOGO 69

PROJECT DETAILS

VM SHOE DISPLAY

DRAWING TITLE

VM SHOE DISPLAY LARGE BASE

DRAWN BY

J LANGSTON

DATE

15/07/10

PART NO

L69-VMSD-001

SCALE

* @A3

DWG NO

L69-VMSD-001

REVISION

*

COPYRIGHT © SMITH BREWER LTD

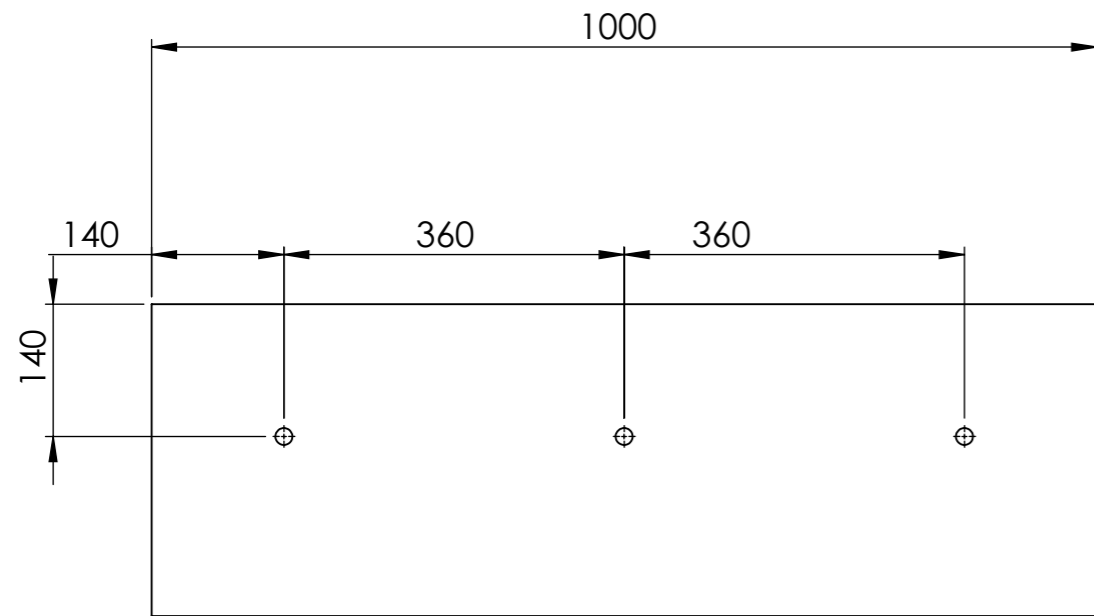

18mm CLEARANCE HOLES TO ACCEPT 16mm THREADED SPIGOT

25mm BIRCH PLYWOOD/MDF

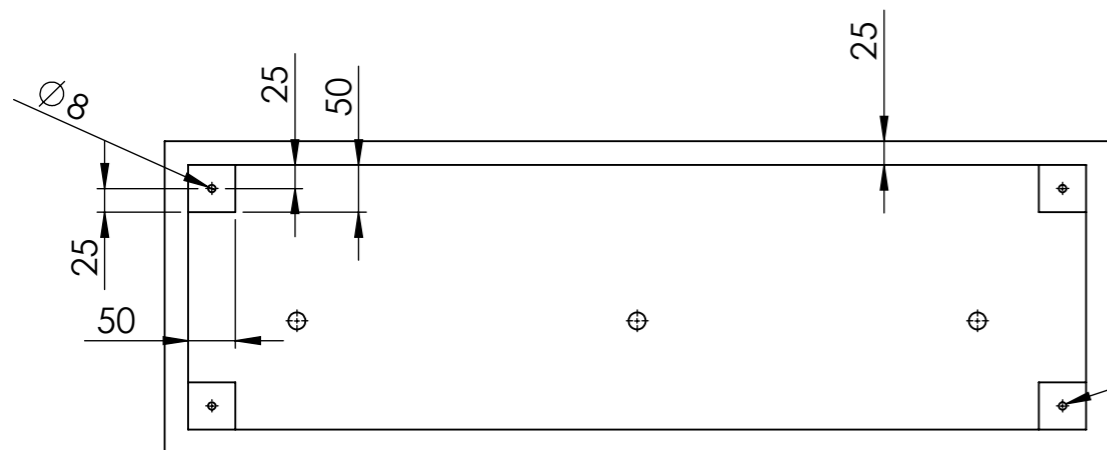
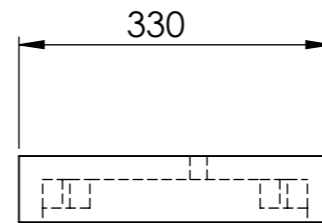
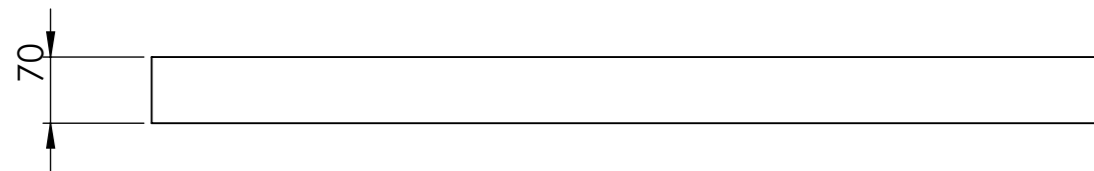
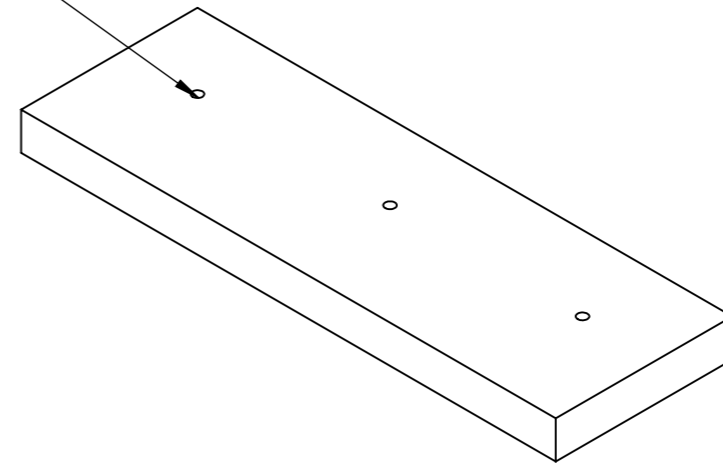

SOFTWOOD BLOCKS WITH M8 THREADED INSERTS TO TAKE SCREW ADJUSTABLE FEET

FINISH: CORAL 162C, FOR APPLICATION SEE NOTES

NOTES			
FINISH OPTIONS-			
-BIRCH PLY WITH WASHED PMS 162C CORAL			
-MDF PAINTED PANEL MATTE FINISH PMS 162C CORAL			
MATERIAL			
25mm BIRCH PLYWOOD/MDF			
FINISH			
SEE NOTES			
WEIGHT			
*			
REVISIONS			
REV	DETAILS	BY	DATE
*	*	*	*
CLIENT			
LOGO 69			
PROJECT DETAILS			
VM SHOE DISPLAY			
DRAWING TITLE			
VM SHOE DISPLAY SMALL BASE			
DRAWN BY		DATE	
J LANGSTON		15/07/10	
PART NO		SCALE	
L69-VMSD-002		* @A3	
DWG NO		REVISION	
L69-VMSD-002		*	
COPYRIGHT © SMITH BREWER LTD			

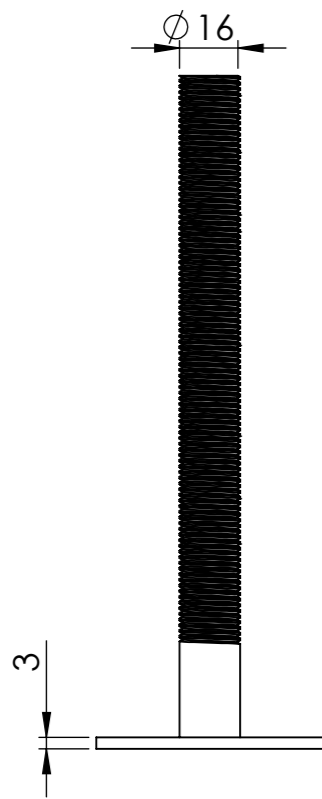
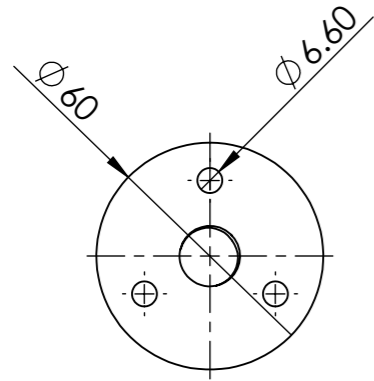

MILD STEEL CONSTRUCTION

THREADED 16mm
BAR

3mm BASE PLATE

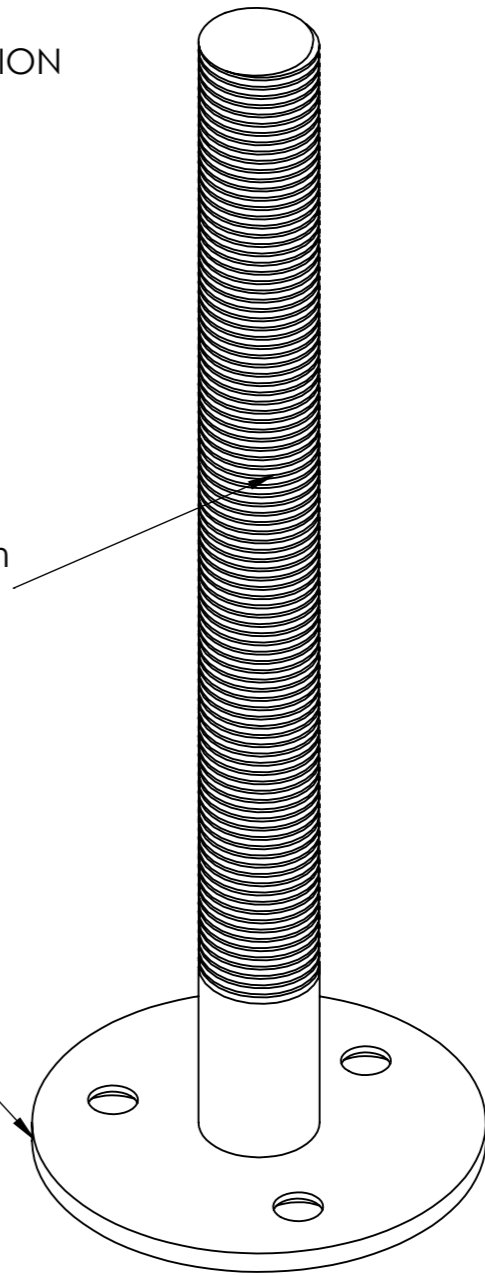

NOTES

*

MATERIAL

MILD STEEL

FINISH

RAW

WEIGHT

*

REVISIONS

REV	DETAILS	BY	DATE
*	*	*	*



CLIENT
LOGO 69

PROJECT DETAILS
VM SHOE DISPLAY

DRAWING TITLE
BASE SPIGOT

DRAWN BY J LANGSTON	DATE 15/07/10
------------------------	------------------

PART NO L69-VMSD-003	SCALE * @A3
-------------------------	----------------

DWG NO L69-VMSD-003	REVISION *
------------------------	---------------

FINISH: RAW

9 NO. BASE TUBES SUPPLIED PER COMPLETE UNIT

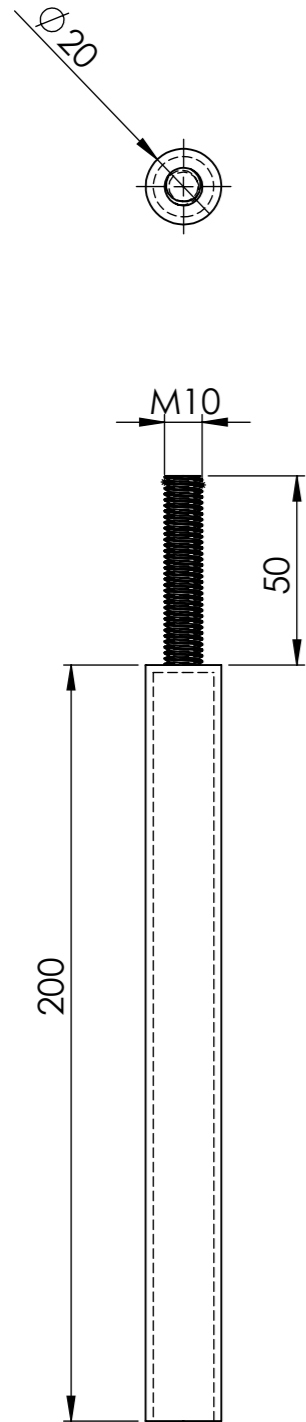

20mm BRUSHED STAINLESS STEEL TUBE WITH 2mm WALL THICKNESS

TAPPED INTERNALLY TO THREAD ONTO M16 BASE SPIGOT



FINISH: BRUSHED STAINLESS STEEL

NOTES			
*			
MATERIAL			
20mm DIAMETER BRUSHED STAINLESS STEEL TUBE WITH 2mm WALL THICKNESS			
FINISH			
BRUSHED			
WEIGHT			
*			
REVISIONS			
REV	DETAILS	BY	DATE
*	*	*	*
			
CLIENT			
LOGO 69			
PROJECT DETAILS			
VM SHOE DISPLAY			
DRAWING TITLE			
SPHERE SUPPORT TUBE			
DRAWN BY		DATE	
J LANGSTON		15/07/10	
PART NO		SCALE	
L69-VMSD-004		* @A3	
DWG NO		REVISION	
L69-VMSD-004		*	

NO. BASE TUBES SUPPLIED PER COMPLETE UNIT TBC

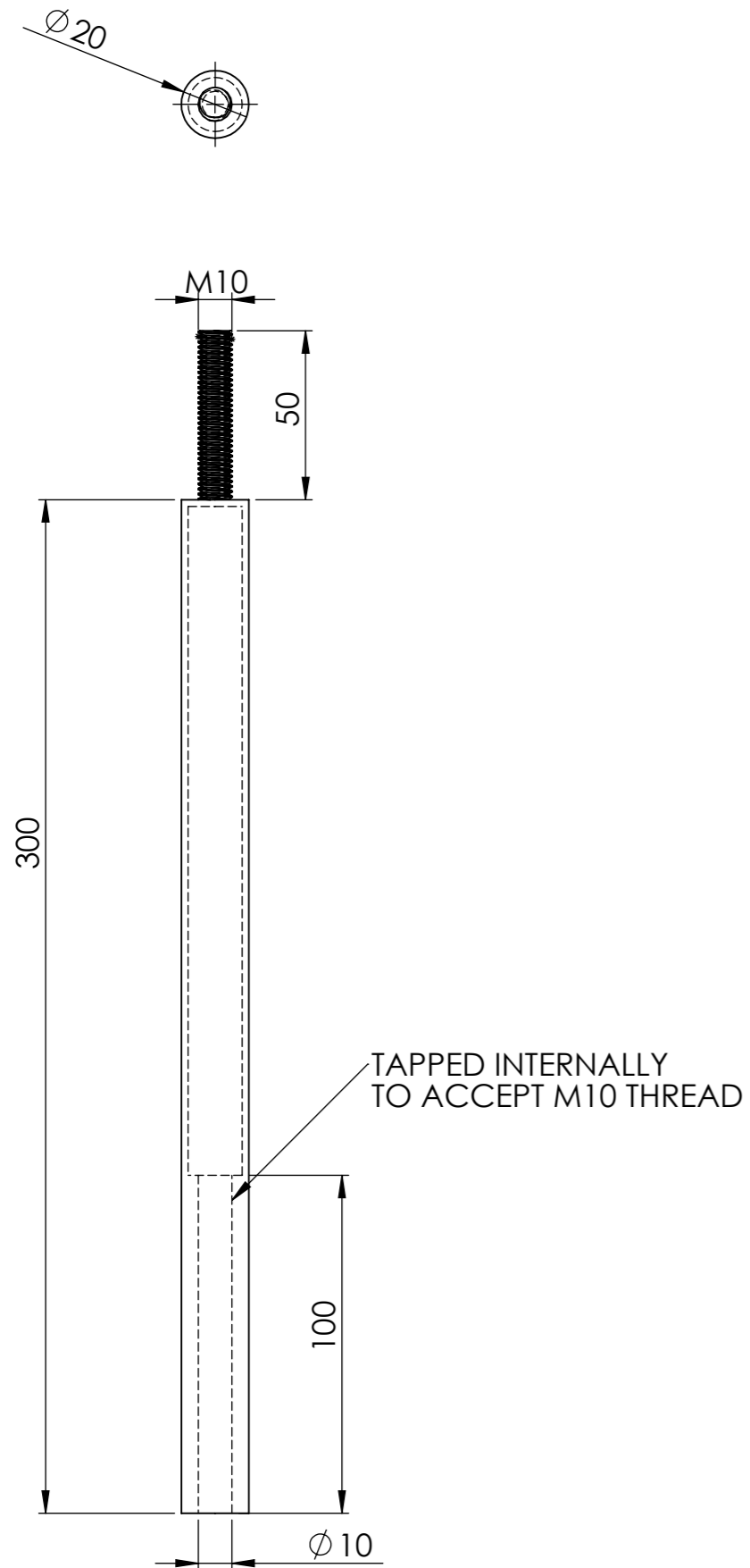

FINISH: BRUSHED STAINLESS STEEL

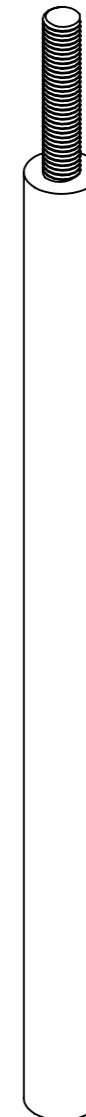

NOTES			
*			
MATERIAL			
20mm DIAMETER BRUSHED STAINLESS STEEL TUBE WITH 2mm WALL THICKNESS			
FINISH			
BRUSHED			
WEIGHT			
*			
REVISIONS			
REV	DETAILS	BY	DATE
*	*	*	*
			
CLIENT			
LOGO 69			
PROJECT DETAILS			
VM SHOE DISPLAY			
DRAWING TITLE			
SPHERE SUPPORT TUBE EXTENSION			
DRAWN BY		DATE	
J LANGSTON		15/07/10	
PART NO		SCALE	
L69-VMSD-005		* @A3	
DWG NO		REVISION	
L69-VMSD-005		*	

EXACT QUANTITIES PER VM PACK TBC

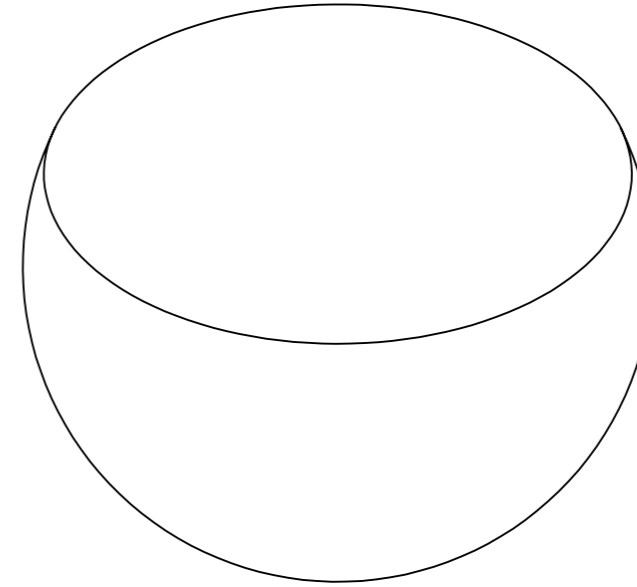
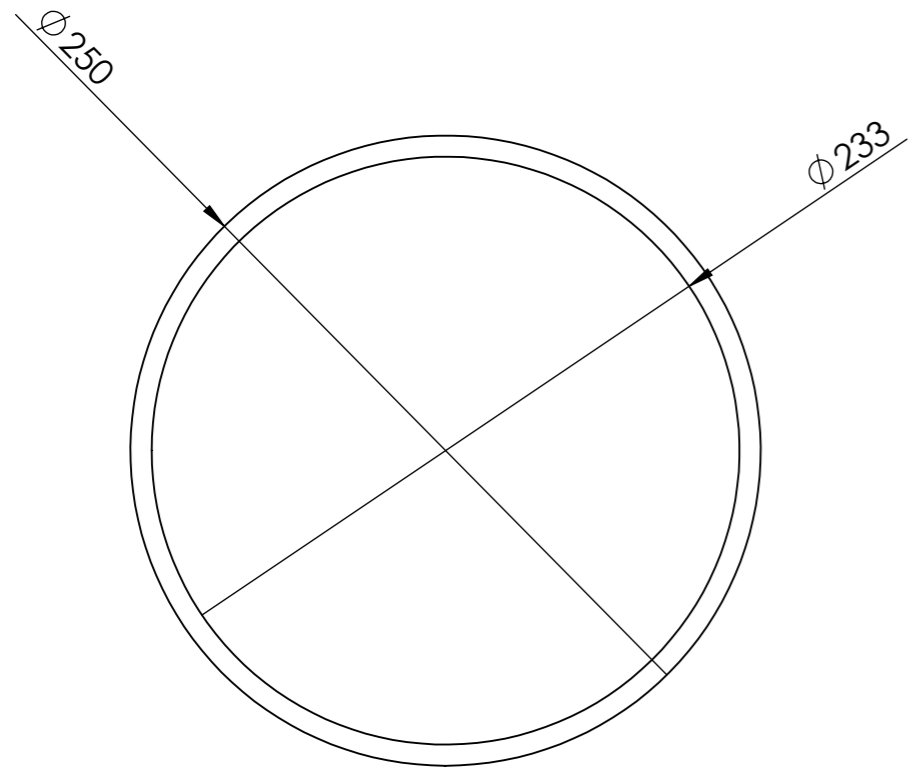

SPHERE SCREWS DOWN ONTO
THREADED SUPPORT BAR

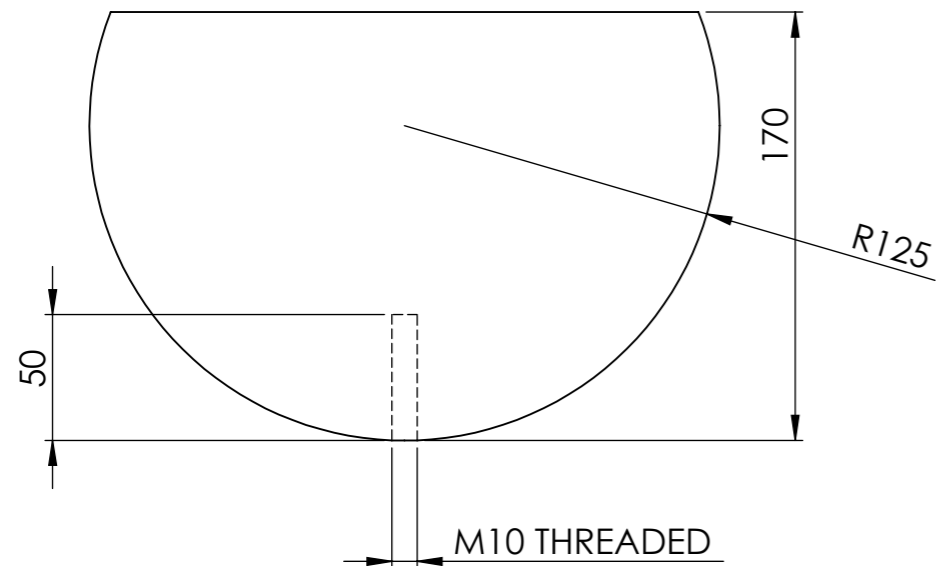

FINISH: SPRAYED HIGH GLOSS

NOTES			
*			
MATERIAL			
SPUN METAL/ACRYLIC			
FINISH			
PAINTED HIGH GLOSS - FOR COLOURS SEE NOTES			
WEIGHT			
*			
REVISIONS			
REV	DETAILS	BY	DATE
*	*	*	*
			
CLIENT			
LOGO 69			
PROJECT DETAILS			
VM SHOE DISPLAY			
DRAWING TITLE			
250mm DIAMETER 3/4 SPHERE			
DRAWN BY		DATE	
J LANGSTON		15/07/10	
PART NO		SCALE	
L69-VMSD-006		* @A3	
DWG NO		REVISION	
L69-VMSD-006		*	

EXACT QUANTITIES PER VM PACK TBC

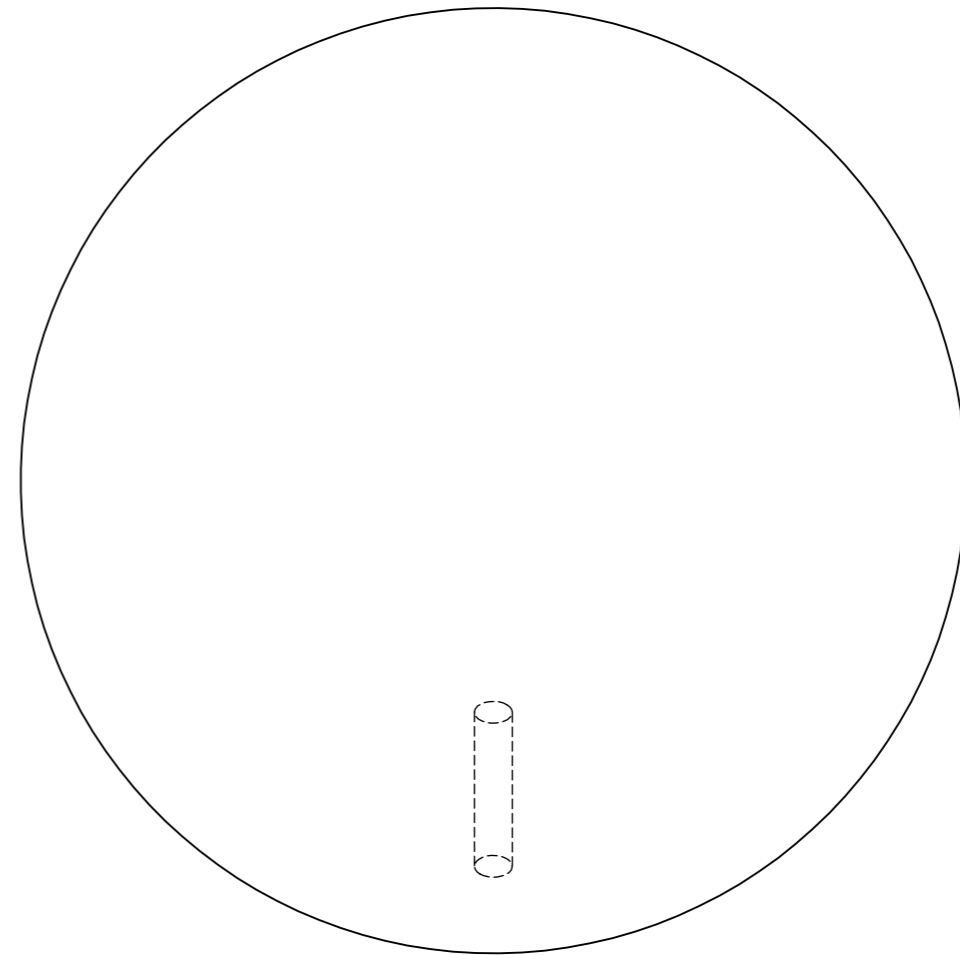

SPHERE SCREWS DOWN ONTO
THREADED SUPPORT BAR

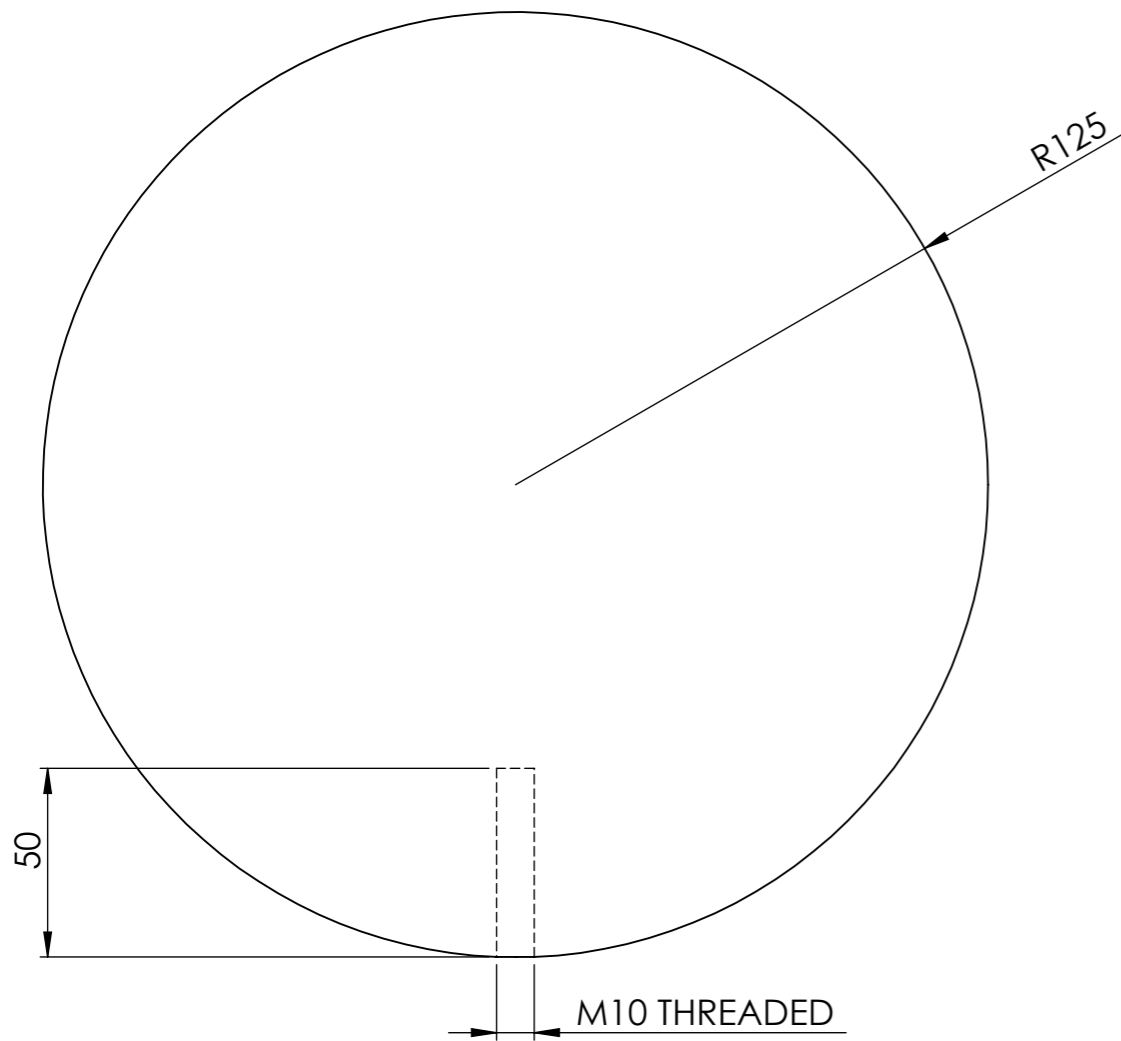

FINISH: SPRAYED HIGH GLOSS

NOTES

*

MATERIAL

SPUN METAL/ACRYLIC

FINISH

PAINTED HIGH GLOSS - FOR COLOURS SEE NOTES

WEIGHT

*

REVISIONS

REV	DETAILS	BY	DATE
-----	---------	----	------

*	*	*	*
---	---	---	---



CLIENT
LOGO 69

PROJECT DETAILS
VM SHOE DISPLAY

DRAWING TITLE
250mm DIAMETER SPHERE

DRAWN BY J LANGSTON	DATE 15/07/10
------------------------	------------------

PART NO L69-VMSD-007	SCALE * @A3
-------------------------	----------------

DWG NO L69-VMSD-007	REVISION *
------------------------	---------------

EXACT QUANTITIES PER VM PACK TBC

SPHERE SCREWS DOWN ONTO
THREADED SUPPORT BAR

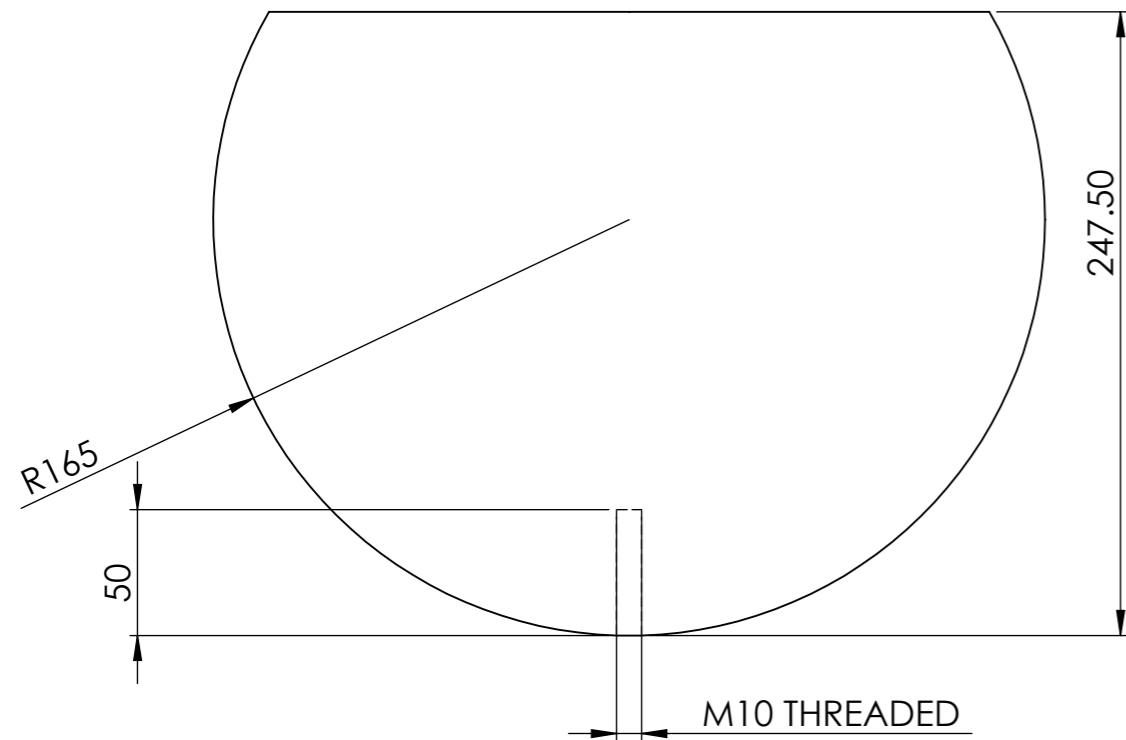
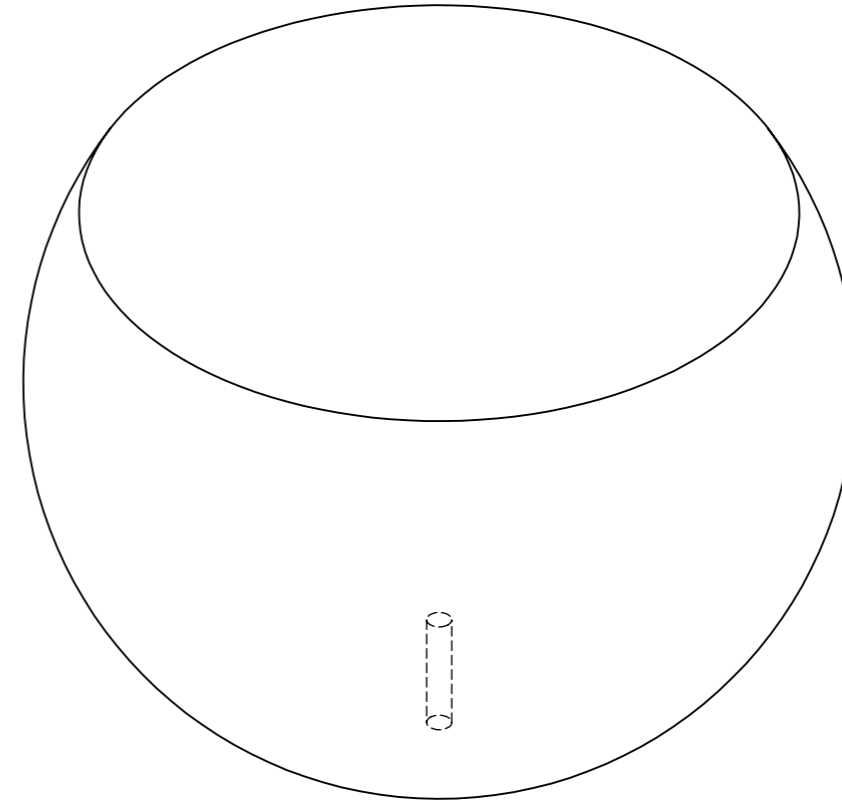
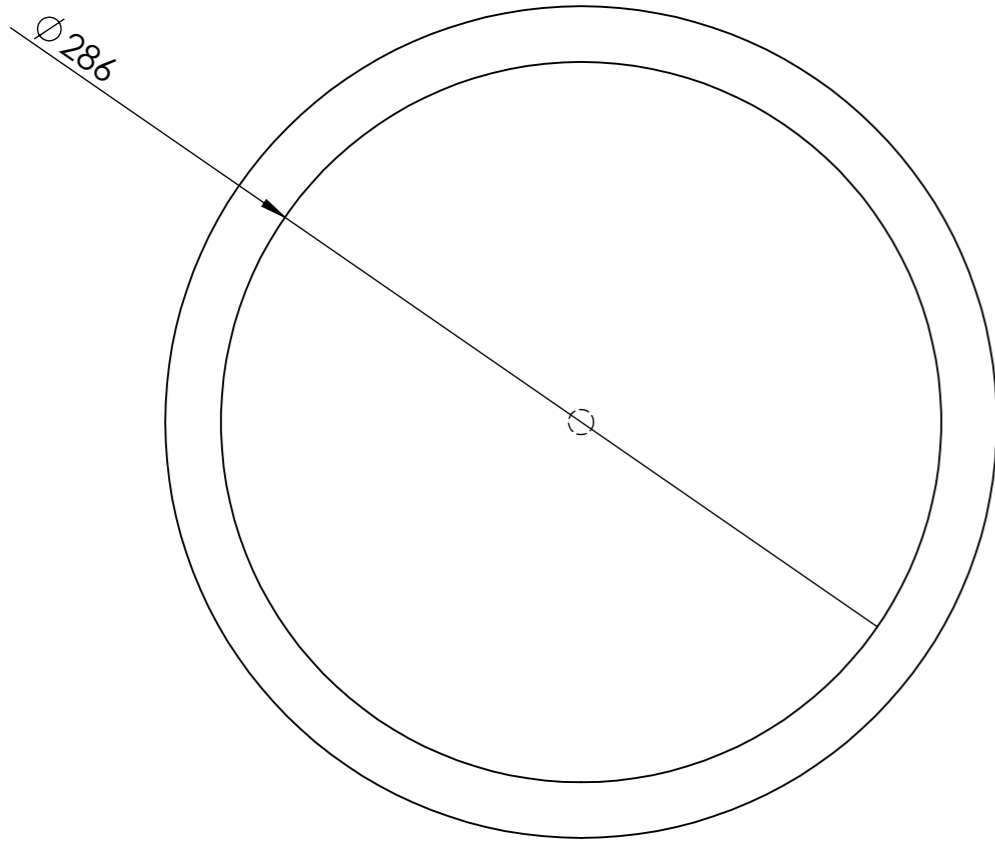

FINISH: SPRAYED HIGH GLOSS

NOTES

*

MATERIAL

SPUN METAL/ACRYLIC

FINISH

PAINTED HIGH GLOSS - FOR COLOURS SEE NOTES

WEIGHT

*

REVISIONS

REV	DETAILS	BY	DATE
*	*	*	*

CLIENT

LOGO 69

PROJECT DETAILS

VM SHOE DISPLAY

DRAWING TITLE

330mm DIAMETER 3/4 SPHERE

DRAWN BY

J LANGSTON

DATE

15/07/10

PART NO

L69-VMDS-008

SCALE

* @A3

DWG NO

L69-VMDS-008

REVISION

*



EXACT QUANTITIES PER VM PACK TBC

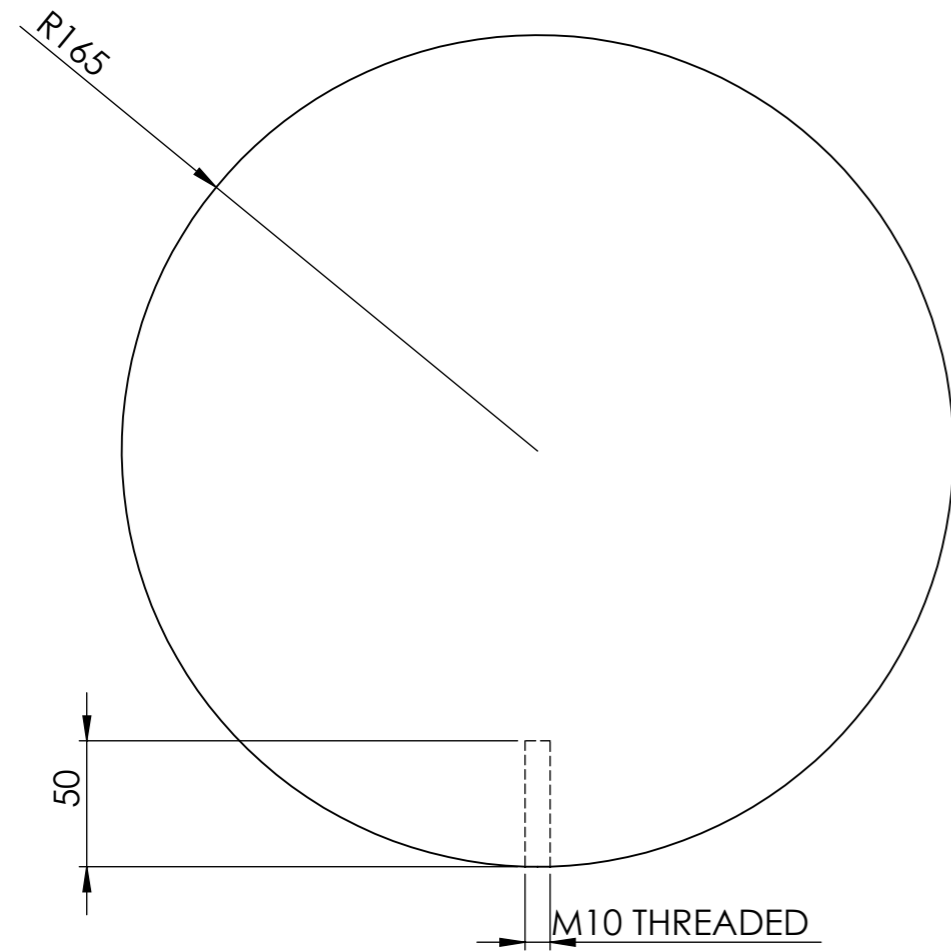

FINISH: SPRAYED HIGH GLOSS

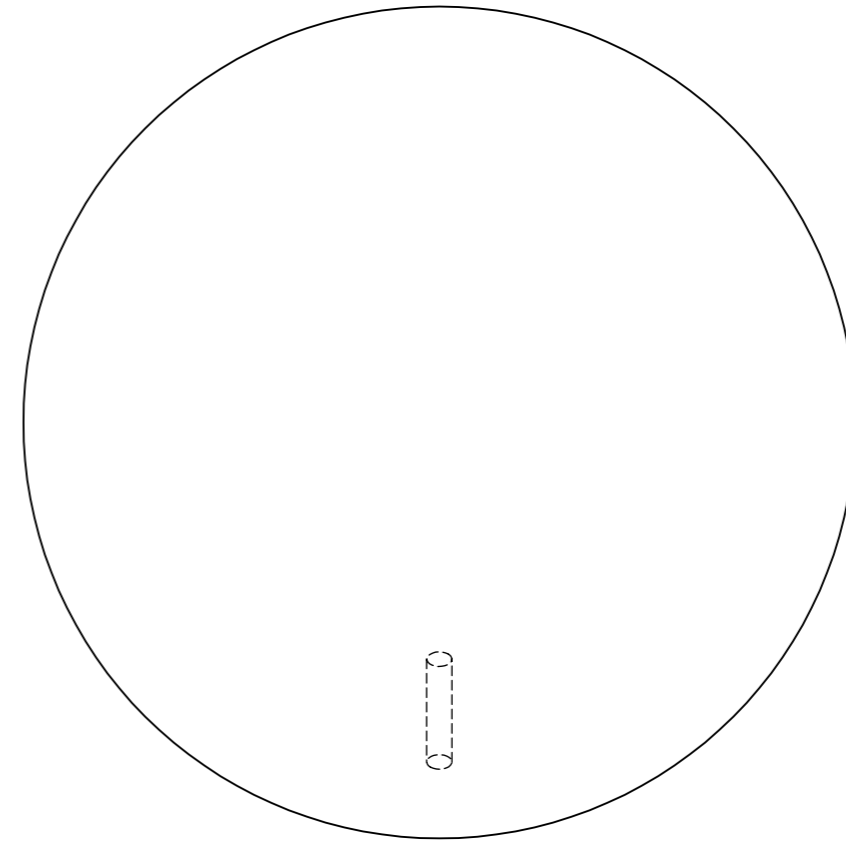

SPHERE SCREWS DOWN ONTO THREADED SUPPORT BAR

NOTES			
*			
MATERIAL			
SPUN METAL/ACRYLIC			
FINISH			
PAINTED HIGH GLOSS - FOR COLOURS SEE NOTES			
WEIGHT			
*			
REVISIONS			
REV	DETAILS	BY	DATE
*	*	*	*
			
CLIENT			
LOGO 69			
PROJECT DETAILS			
VM SHOE DISPLAY			
DRAWING TITLE			
330mm DIAMETER SPHERE			
DRAWN BY		DATE	
J LANGSTON		15/07/10	
PART NO		SCALE	
L69-VMSD-009		* @A3	
DWG NO		REVISION	
L69-VMSD-009		*	

8 NO. SCREW ADJUSTABLE FEET (4 PER BASE)

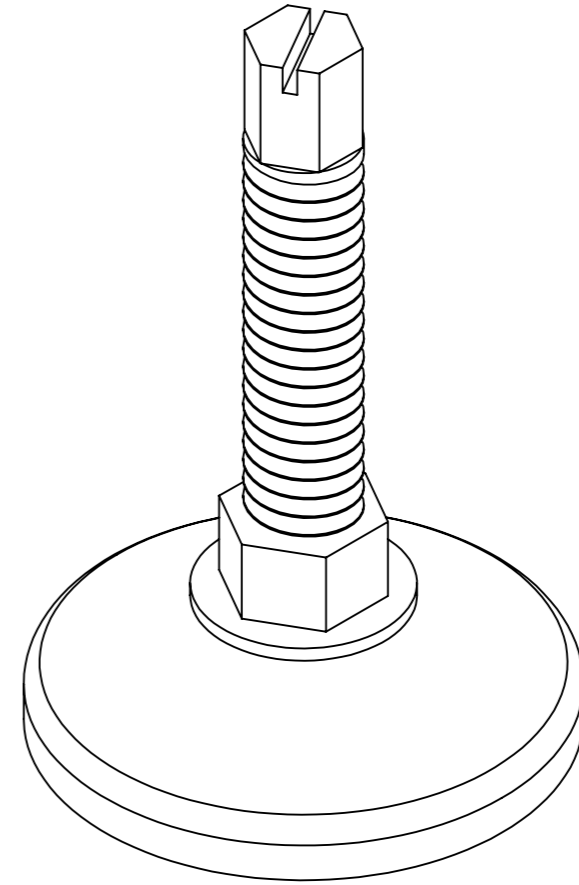
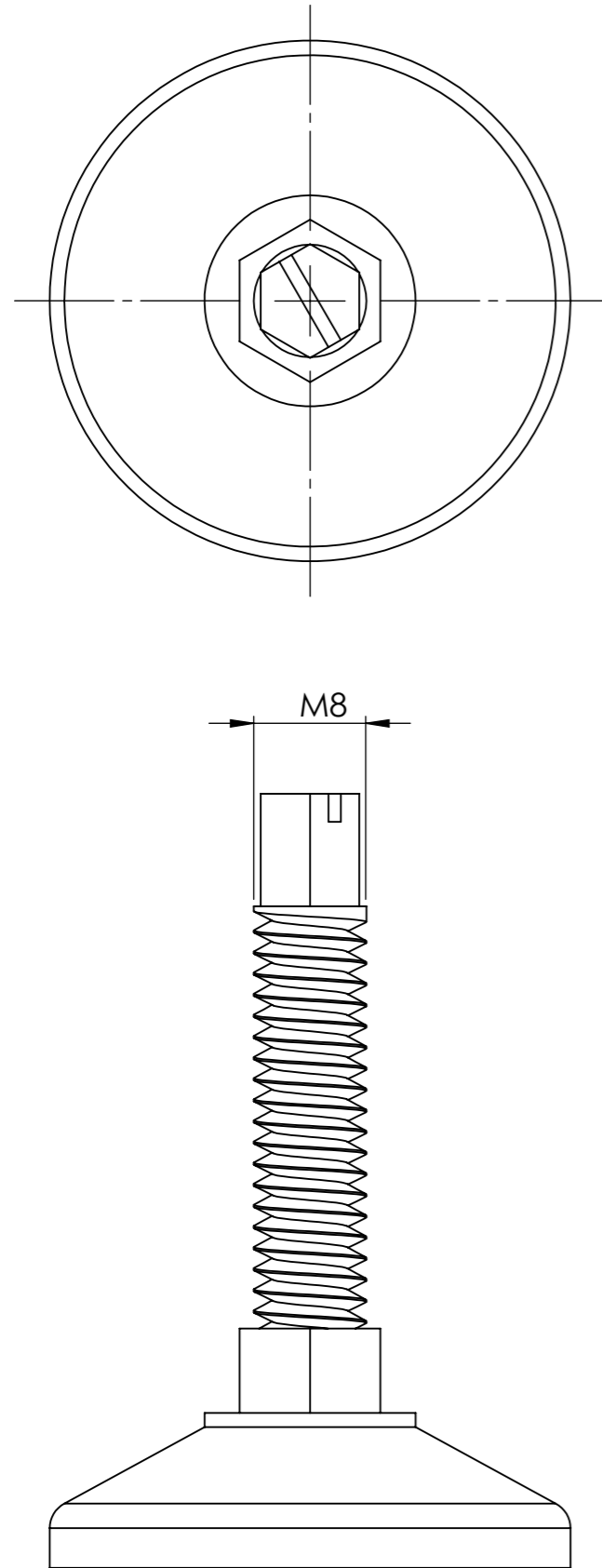

NOTES			
*			
MATERIAL			
NA			
FINISH			
NA			
WEIGHT			
*			
REVISIONS			
REV	DETAILS	BY	DATE
*	*	*	*
			
CLIENT			
LOGO 69			
PROJECT DETAILS			
VM SHOE DISPLAY			
DRAWING TITLE			
M8 SCREW ADJUSTABLE FOOT			
DRAWN BY		DATE	
J LANGSTON		15/07/10	
PART NO		SCALE	
L69-VMDS-010		* @A3	
DWG NO		REVISION	
L69-VMDS-010		*	