

UNLESS OTHERWISE SPECIFIED: DIMENSIONS ARE IN MILLIMETERS SURFACE FINISH: TOLERANCES: LINEAR: ANGULAR:			FINISH:		DEBUR AND BREAK SHARP EDGES		DO NOT SCALE DRAWING		REVISION		
DRAWN							TITLE:		<b>SOFTRAY</b> <b>8 LED SPOTLIGHT</b> <b>ORTHOGONAL</b>		
CHK'D							DWG NO.				
APPV'D							MATERIAL:		SCALE:1:5		
MFG							WEIGHT:		SHEET 1 OF 2		
Q.A											

ITEM NO.	PART NUMBER	QTY.
1	BACK SHELL SECTION	1
2	CONNECTOR BOLT	1
3	FRONT SHELL SECTION	1
4	SPRING	1
5	INLET CONNECTOR	1
6	INLET NUT	1
7	RUBBER STOPPER	1
8	INLET CAP	1
9	BRACKET SUPPORT	1
10	BRACKET SUPPORT PIN	6
11	M8_15 BOLT	1
12	WASHER	2
13	M8 NUT	2
14	TENSION PLATE SUPPORT	1
15	TENSION PLATE	1
16	TIGHTENER	1
	TIGHTENER THREAD	1
	TIGHTENER HANDLE	1
17	BRACKET	1
18	M5_15 BOLT	7
19	M5 NUT	7
20	8 LED SUPPORT PLATE	1
21	8 COVER SUPPORT	1
22	LED ASSEMBLY	8
	HEAT SINK	1
	SCREW M1.6_5.5 2	2
	HIGH POWERED LED	1
	REFLECTOR 2	1
	SCREW M3_5.6 2	2
	SCREW M2.7_10 2	3

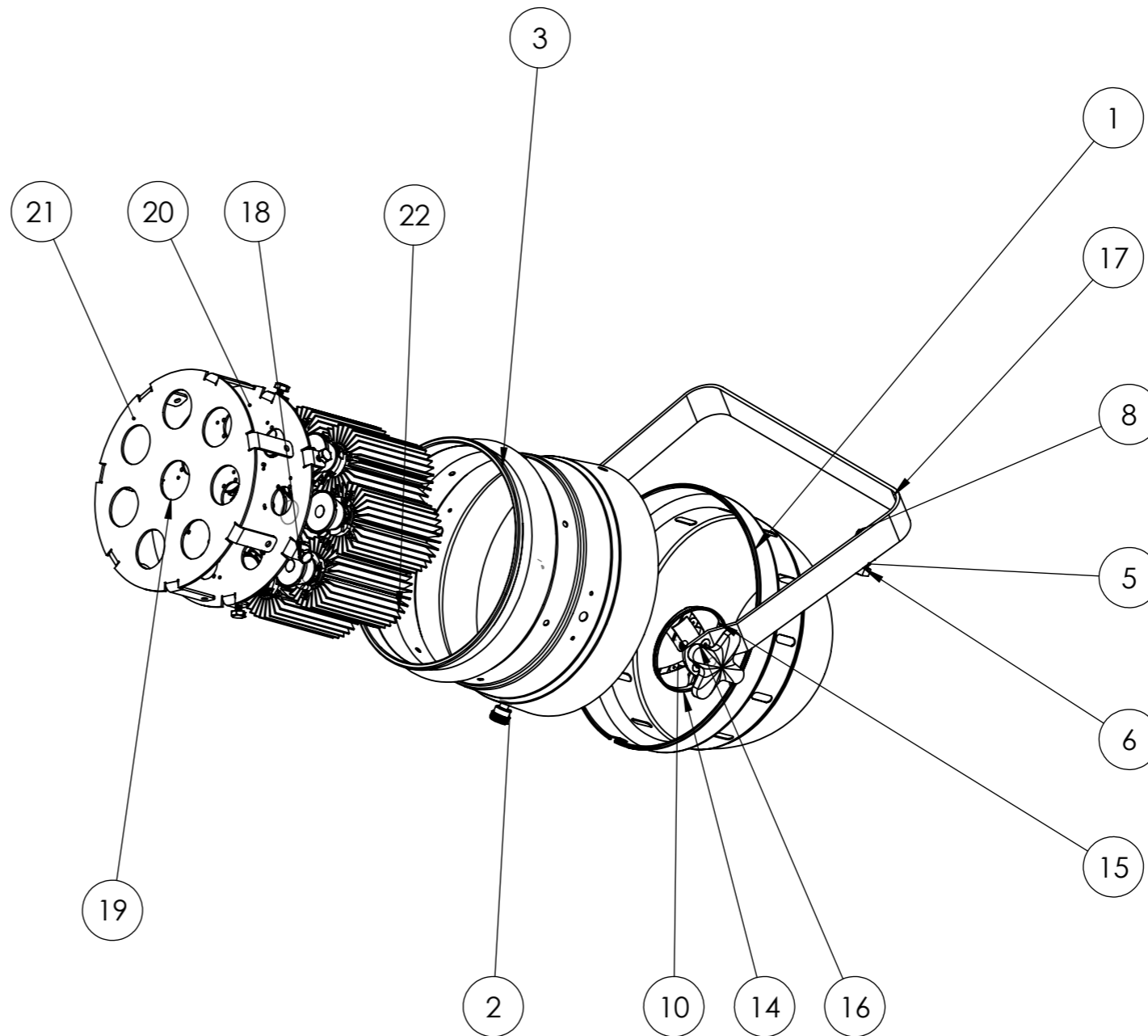

UNLESS OTHERWISE SPECIFIED: DIMENSIONS ARE IN MILLIMETERS SURFACE FINISH: TOLERANCES: LINEAR: ANGULAR:		FINISH:	DEBUR AND BREAK SHARP EDGES		DO NOT SCALE DRAWING	REVISION
NAME	SIGNATURE	DATE			TITLE: <b>8 LED SPOTLIGHT EXPLODED</b>	
DRAWN					DWG NO. <b>SRDWG_0036</b>	
CHK'D					A3	
APPV'D					SCALE:1:5	
MFG					SHEET 2 OF 2	
Q.A			MATERIAL:			
			WEIGHT:			