

# Factory Assembly Instructions for: TYLENOL UR SHOPPABLE QTR Promo # 74185

BASE TRAYS (2)  
74185.03

1. Locate Base Trays and break all scores. Fold side panels up as shown and tuck minor flaps (A) inward.

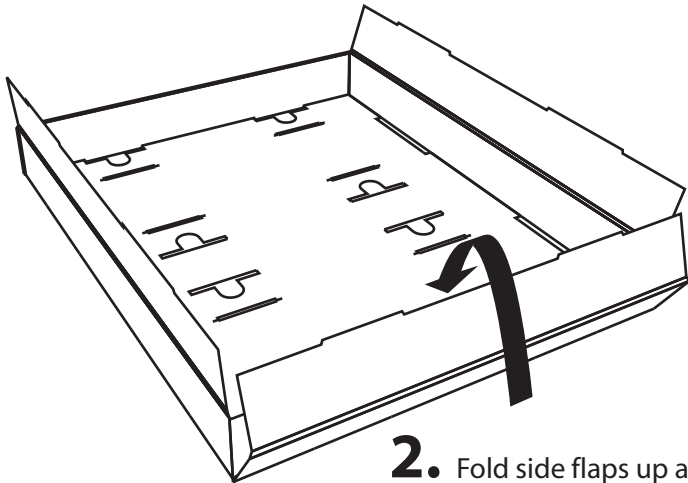
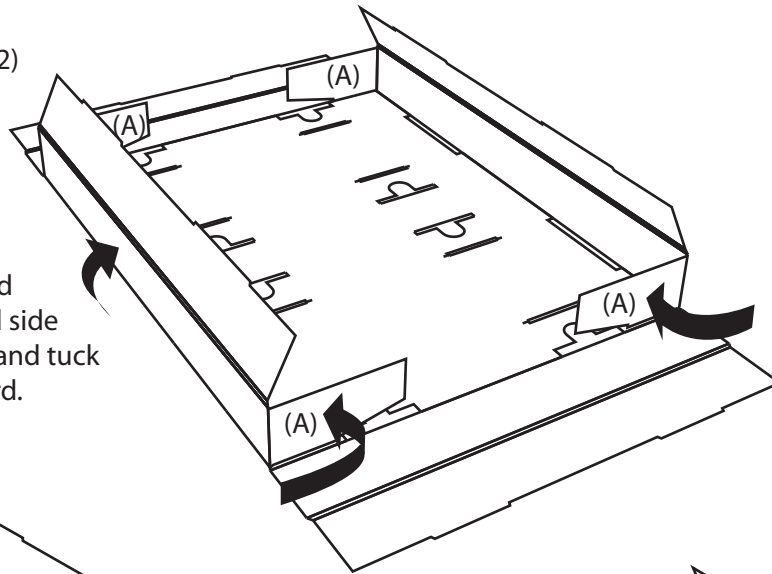

2. Fold side flaps up and over minor flaps and down into Tray and into slots to secure.

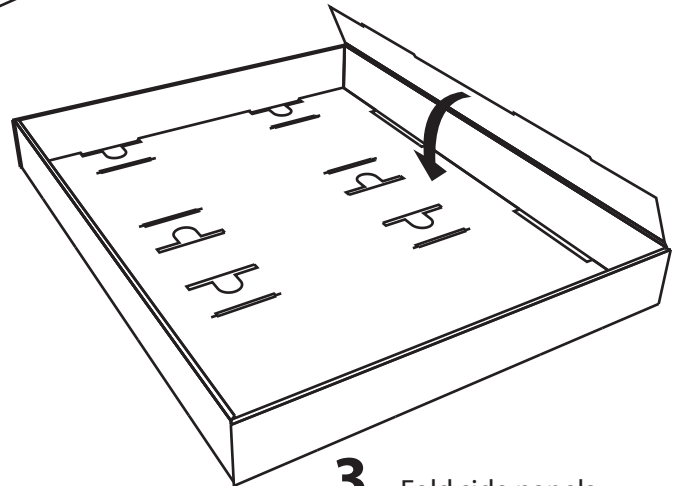

3. Fold side panels down into Tray and into slots to secure.

PEDESTALS (2)  
74185.04

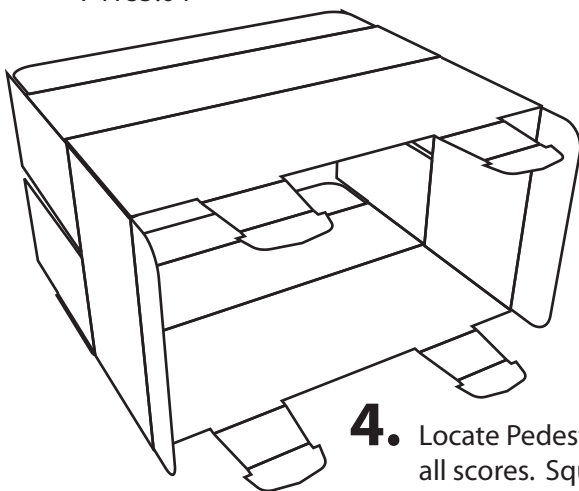

4. Locate Pedestals and break all scores. Square up to appear as shown.

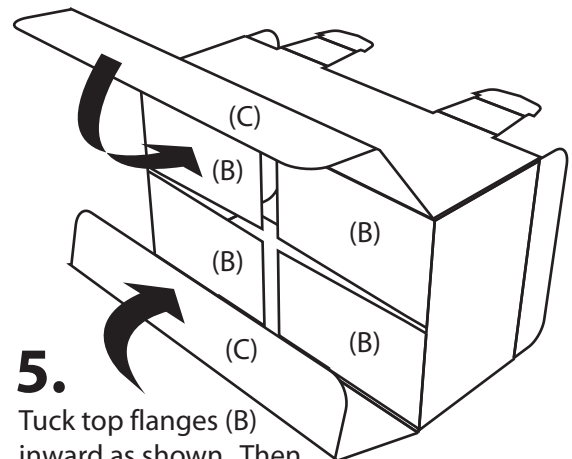

5. Tuck top flanges (B) inward as shown. Then fold top panels (C) down and into slots of top flanges to secure.

# Factory Assembly Instructions for: TYLENOL UR SHOPPABLE QTR Promo # 74185

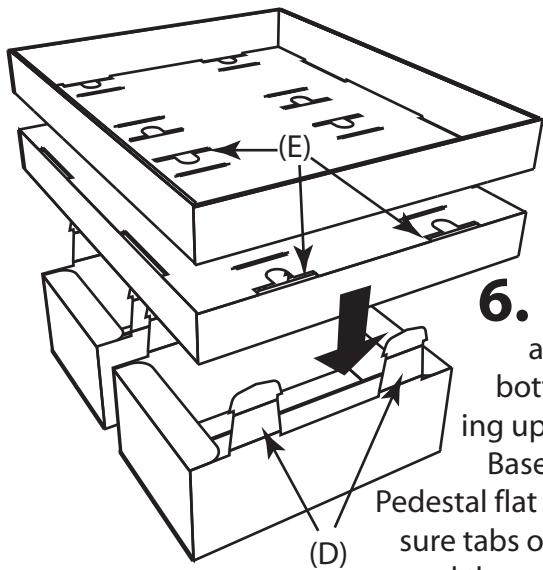

**6.** Set Pedestals on a flat surface with bottom tabs (D) facing upward. Place first Base Tray down over Pedestal flat side up, making sure tabs of Pedestal insert upward through outer slots of Base Tray (E).

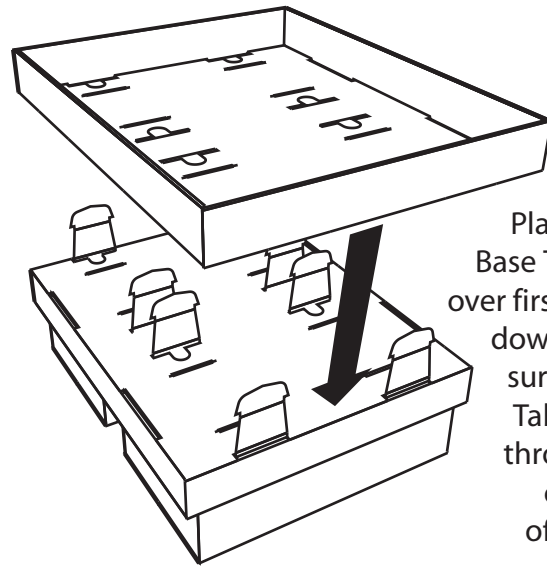

**7.** Place second Base Tray down over first (flat side down) making sure Pedestal Tabs pass up through same outer slots of Base Tray.

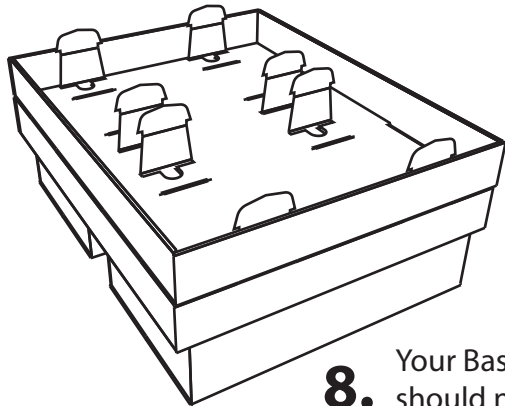

**8.** Your Base Assembly should now look like this.

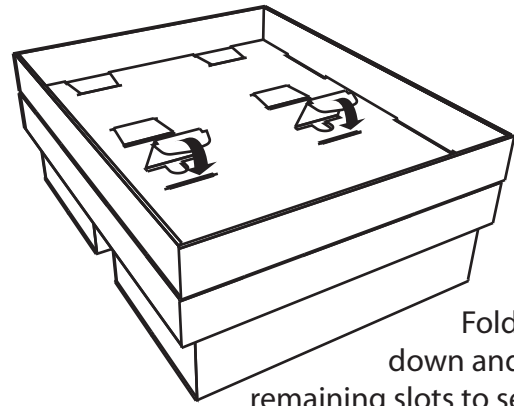

**9.** Fold tabs down and into remaining slots to secure.

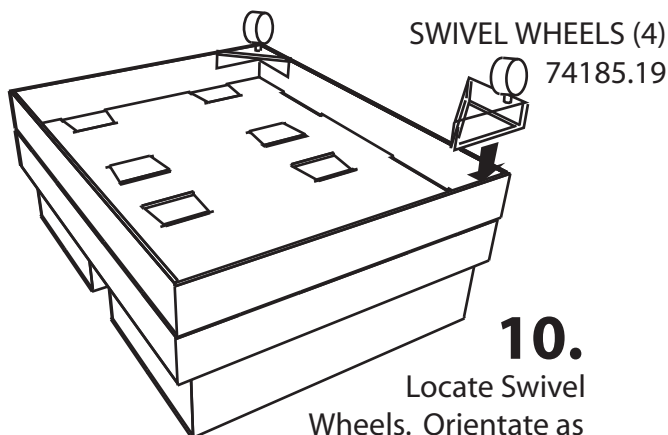

**10.** Locate Swivel Wheels. Orientate as shown and gently but firmly press down over corners of bottom Base Tray.

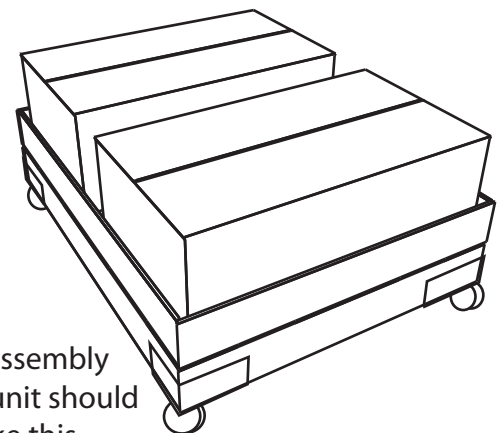

**11.** Turn Base Assembly over. Your unit should now look like this.

# Factory Assembly Instructions for: TYLENOL UR SHOPPABLE QTR Promo # 74185

CENTER CORE X1  
74185.07

**12.**  
Locate Center  
Core and square up  
to appear as shown.

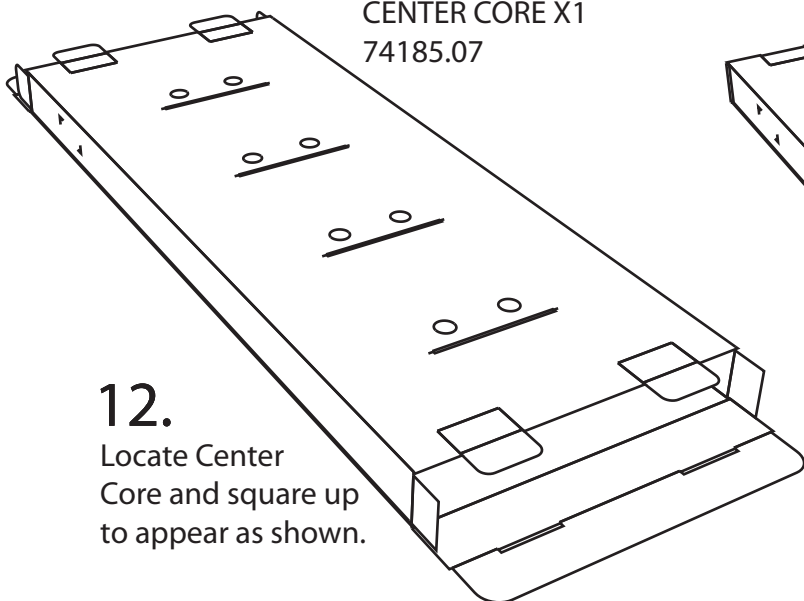

**13.**  
Tuck in minor flaps (F).

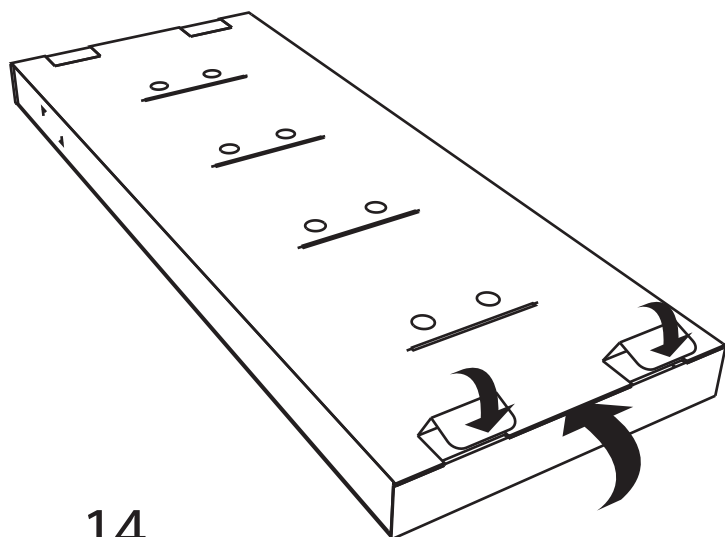
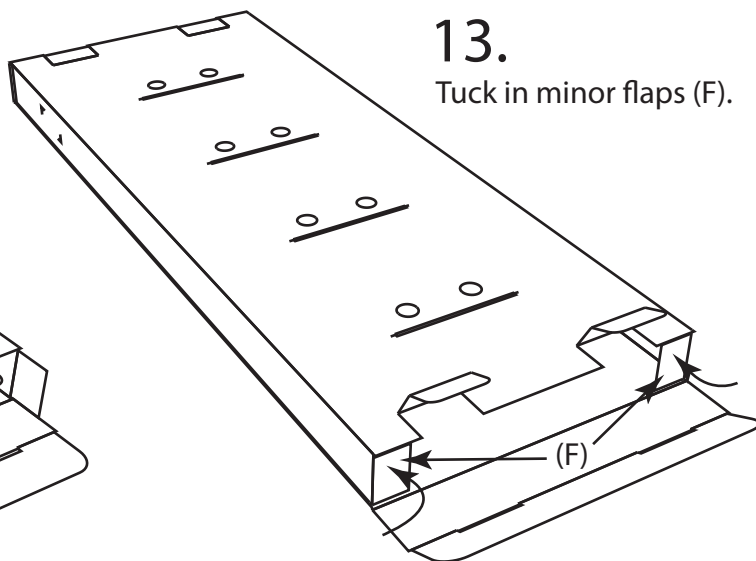

**14.**  
Tuck end panels up and into Center  
Core. Engage Tabs to secure.

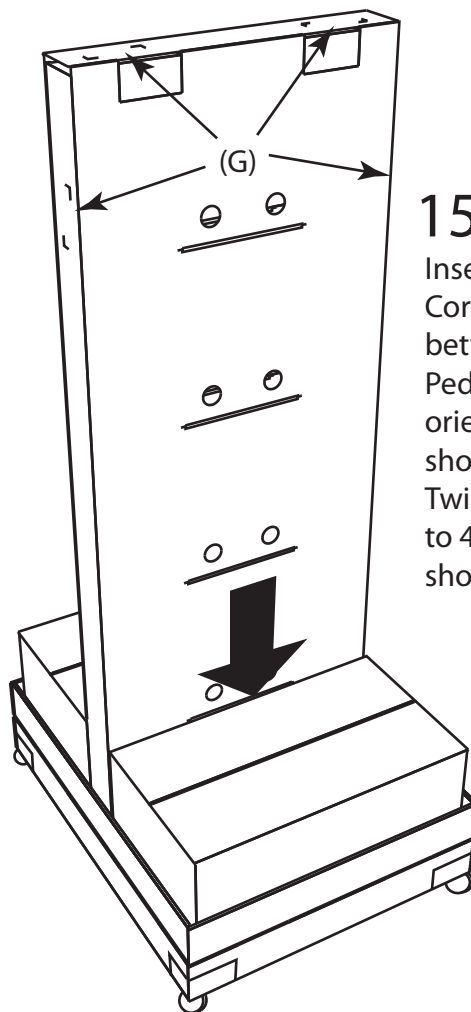

**15.**  
Insert Center  
Core down  
between  
Pedestals  
oriented as  
shown. Apply  
Twinstik (3"X 1")  
to 4 locations  
shown (G).

# Factory Assembly Instructions for: TYLENOL UR SHOPPABLE QTR Promo # 74185

GRAPHIC PANELS (2)  
74185.05 (HEAD) / 74185.06 (BODY)

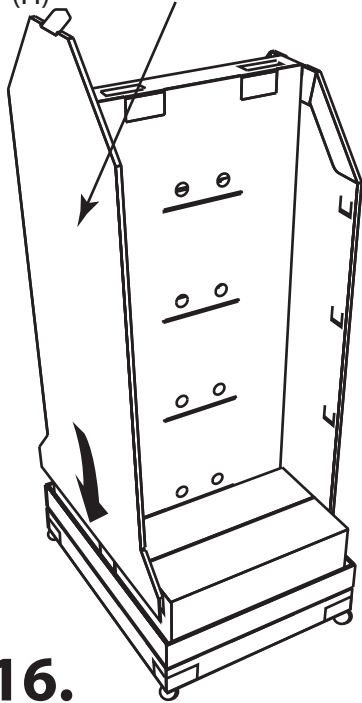

- 16.** Locate Graphic Panels. Insert down between sides of Base Trays and sides of Pedestals. Remove protective covering from Twinstik on sides of Center Core.

SHELF TUBES (6)  
74185.20

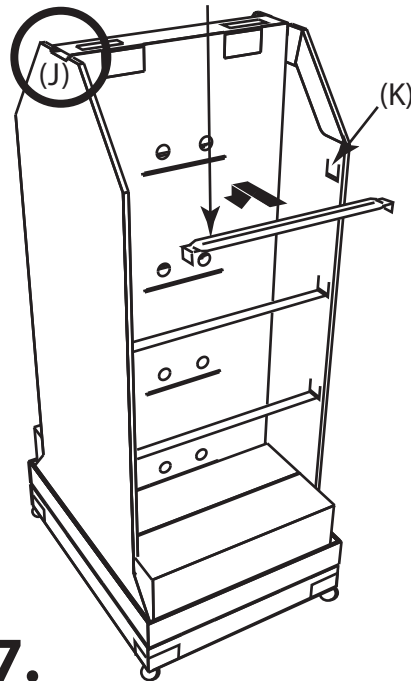

- 17.** Aligning tab at top of Graphic Panel (H) with slot at top of Center Core (J), adhere Graphic Panel to Center Core. Insert Shelf Tubes into display by positioning as shown and hooking down into slots (K) on inside of Graphic Panels.

TRAY SUPPORTS (8)  
74185.09

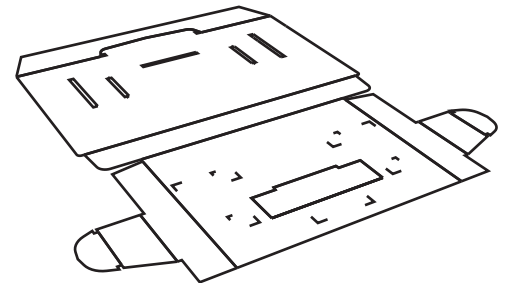

- 18.** Break all scores on Tray Supports.

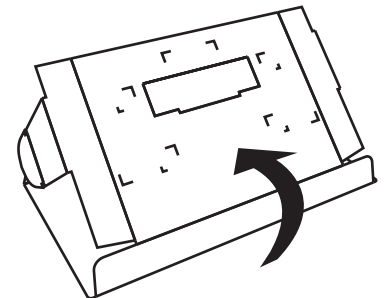

- 19.** Fold front lip panel upward as shown.

(L) 3" x 1"

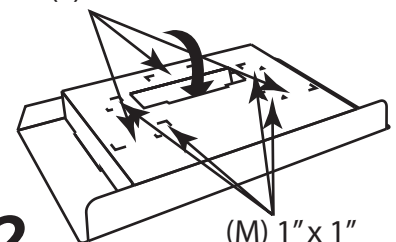

- 22.** Push down on top support flange until it catches into slot. (L) On 7 of the 8 Tray Supports apply 3 pieces of 3" x 1" x 1/16" Twinstik where shown. (M) On remaining Tray Support apply 4 pieces of 1" x 1" x 1/2" where shown.

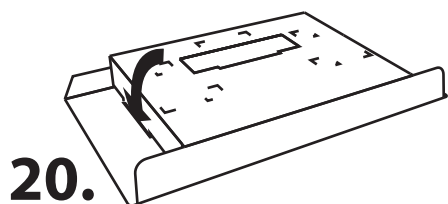

- 20.** Fold top side flanges down while inserting side belt tabs through slots.

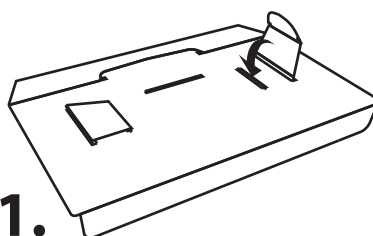

- 21.** Turn Tray Support over and pull belt tabs through and into adjacent slots.

# Factory Assembly Instructions for: TYLENOL UR SHOPPABLE QTR Promo # 74185

VACUUM FORMED TRAYS (8)  
74185.21/ 74185.22/ 74185.23  
74185.24/ 74185.25/ 74185.26  
74185.27/ 74185.28

TRAY GRAPHICS (8)  
74185.29/ 74185.30/ 74185.31/ 74185.32  
74185.33/ 74185.34/ 74185.35/ 74185.36

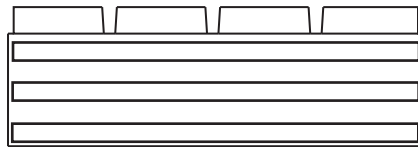
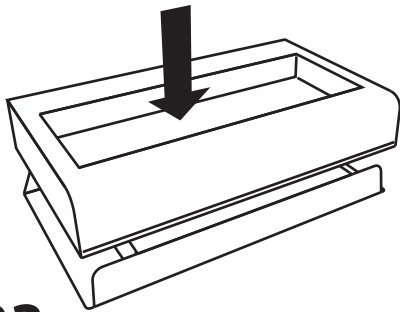
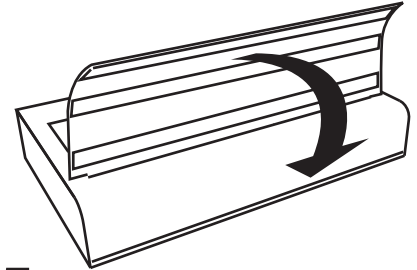

**24.** Locate Tray Graphics and break scores. Apply Double Sided Tape (15+1/2" X 3/4"(24 pcs)) where shown.

**25.** Using DIAGRAM 1 BELOW match up Vacuum Formed Trays with Tray Graphics. Insert top edge of Graphic down into opening of Trays. Slowly wrap graphic around front of Tray and apply firm pressure over whole length.

**23.** Remove covering from Twinstik on Tray Supports and adhere Vacuum Formed Trays. NOTE: Vacuum Formed Tray HEAD 1 will use Tray Support with 1" x 1" x 1/2" Twinstik.

DIAGRAM 1

HEAD SIDE	BODY SIDE
TOP SHELF TRAY 74185.23-GRAPHIC 74185.29	TOP SHELF TRAY 74185.24-GRAPHIC 74185.33
TRAY 74185.26-GRAPHIC 74185.30	TRAY 74185.22-GRAPHIC 74185.34
TRAY 74185.27-GRAPHIC 74185.31	TRAY 74185.21-GRAPHIC 74185.35
BOTTOM SHELF TRAY 74185.28-GRAPHIC 74185.32	BOTTOM SHELF TRAY 74185.25-GRAPHIC 74185.36

BOTTOM SHIPPER  
FILLER (1)  
74185.12

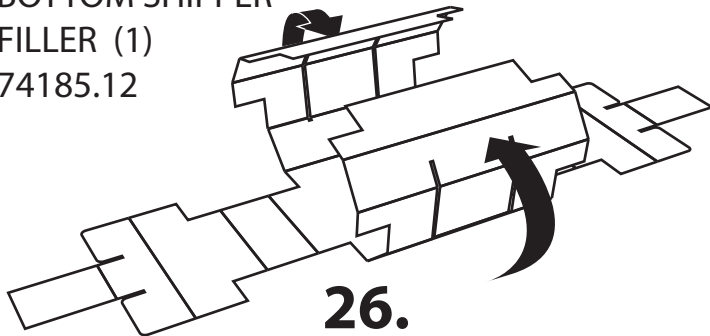

Locate Bottom Shipper Filler and break scores. Roll up side panels up as shown.

TOP/BOTTOM CAP (2)  
74185.02

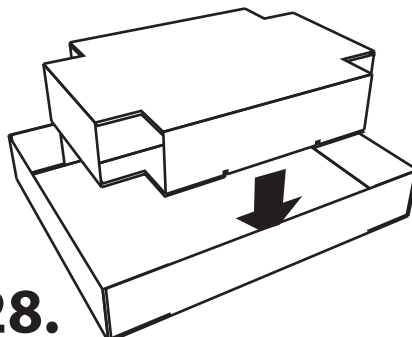

**28.** Fold up sides of Bottom Cap and glue corners to form. Place Bottom Shipper Filler down into center.

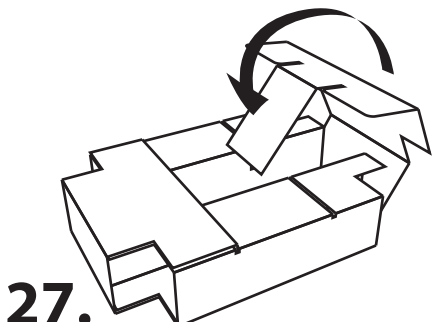

**27.** Roll up ends and interlock slots to secure.

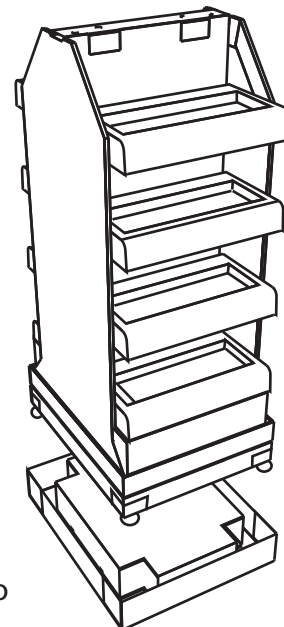

**29.** Using DIAGRAM 1 for placement, insert Trays into unit by inserting Tab on Tray Support into slot in Center Core. Use finger holes for leverage. Bottom trays do not use Tabs. Instead, insert rear turndowns down behind Pedestals.

# Factory Assembly Instructions for: TYLENOL UR SHOPPABLE QTR Promo # 74185

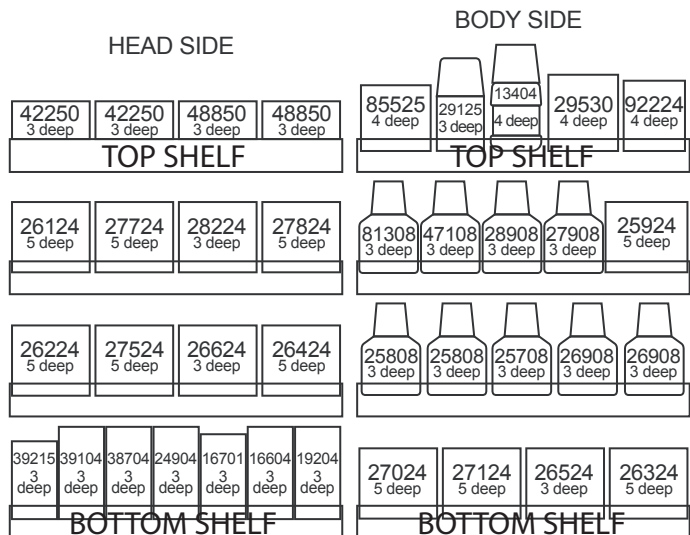

**30.** Fill Display with product. Use above Diagram for product placement.

## SHIPPER FILLER KK (3)

74185.14

HEAD SIDE 2ND AND 3RD SHELVES

BODY SIDE BOTTOM SHELF

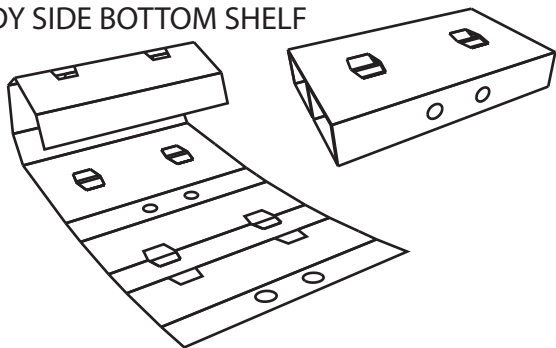

## SHIPPER FILLER MM (1)

74185.15

HEAD SIDE BOTTOM SHELF

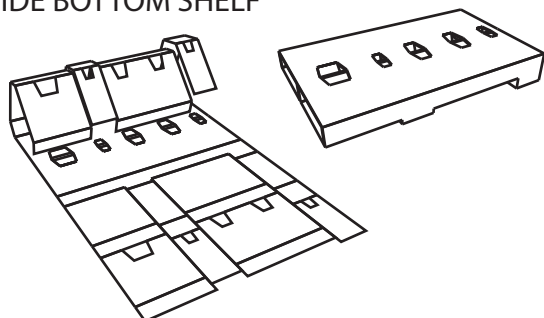

## SHIPPER FILLERS

**31.** Form all Shipper Fillers in same manner. Roll up ends until spines meet. Turn Filler over and push down on tabs to secure.

### SHIPPER FILLER JJ (1)

74185.13

HEAD SIDE

TOP SHELF

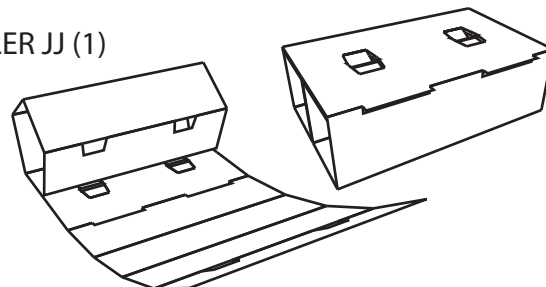

### SHIPPER FILLER NN (1)

74185.16

BODY SIDE

TOP SHELF

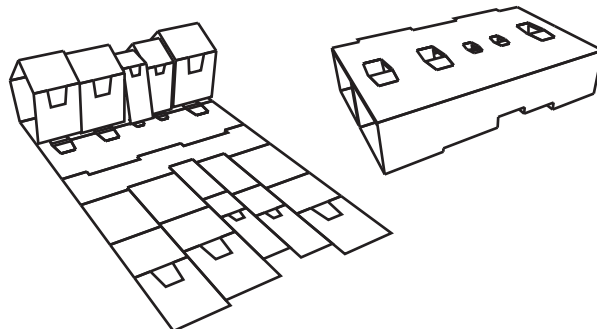

### SHIPPER FILLER PP (1)

74185.17

BODY SIDE

2ND SHELF

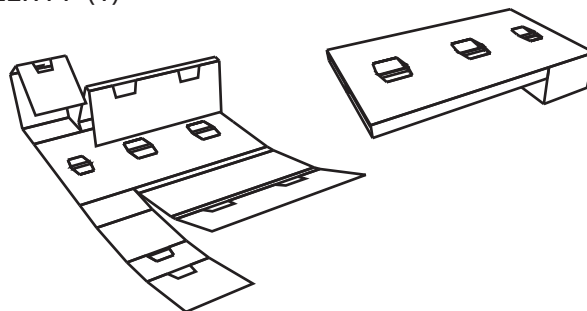

### SHIPPER FILLER QQ (1)

74185.18

BODY SIDE 3RD SHELF

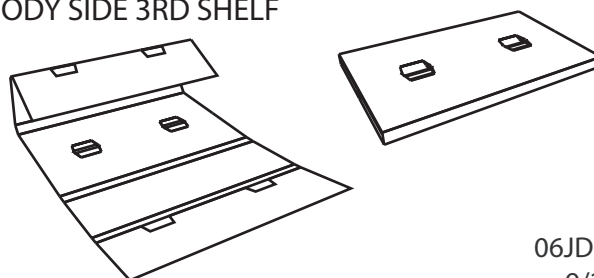

# Factory Assembly Instructions for: TYLENOL UR SHOPPABLE QTR Promo # 74185

## HEAD SIDE

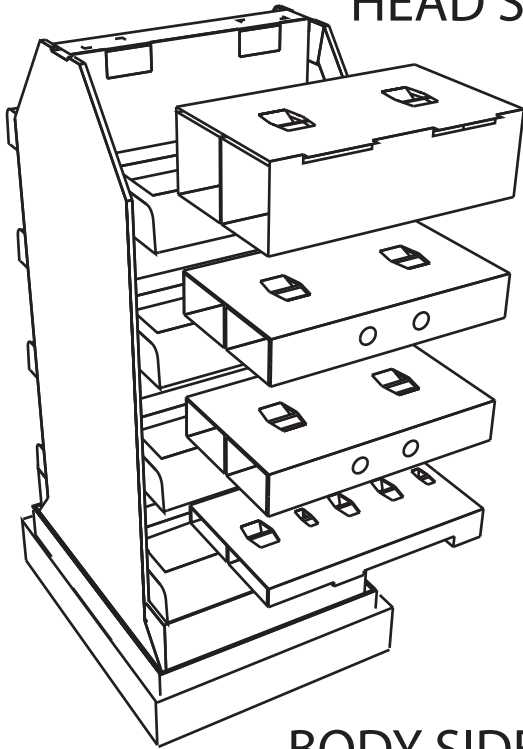

## BODY SIDE

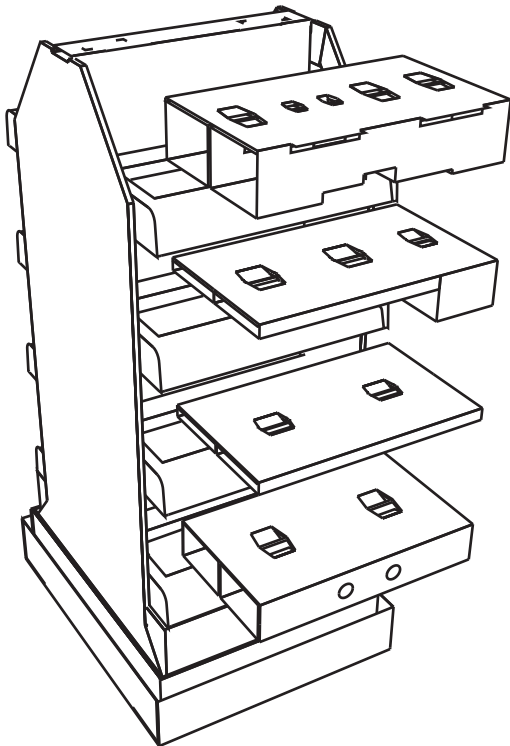

### 32.

Place appropriate Shipper Fillers into Display above product. See DIAGRAM from page 6.

HEADER (1)  
74185.08

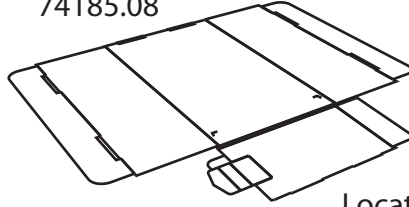

### 33.

Locate Header and fold to appear as shown.

(P)

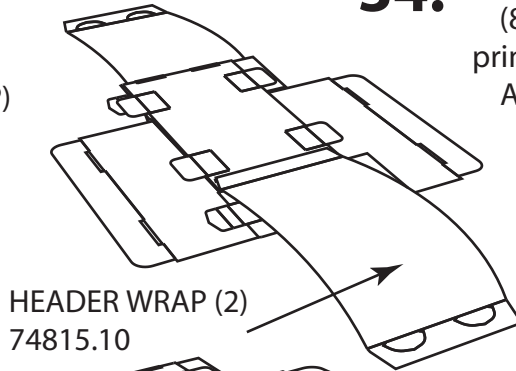

HEADER WRAP (2)  
74815.10

Locate Header Wraps. Break scores.

### 34.

Apply Double sided Tape (8+1/2" X 3/4" (2 pcs)) to print side of tape flaps (P).

Adhere to Header using locator marks for positioning. Flip over and repeat for other side.

Tab (Q) faces downward when finished so make sure text on Header Wrap is orientated correctly.

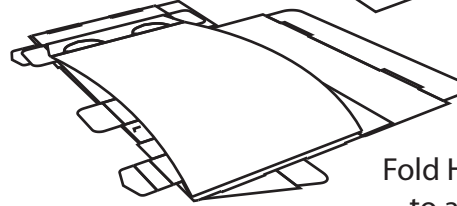

### 35.

Fold Header assembly to appear as shown.

### 36.

Wrap display with Shroud. Drop in Folded Header assembly along side. Place RETAIL SUIS on top.

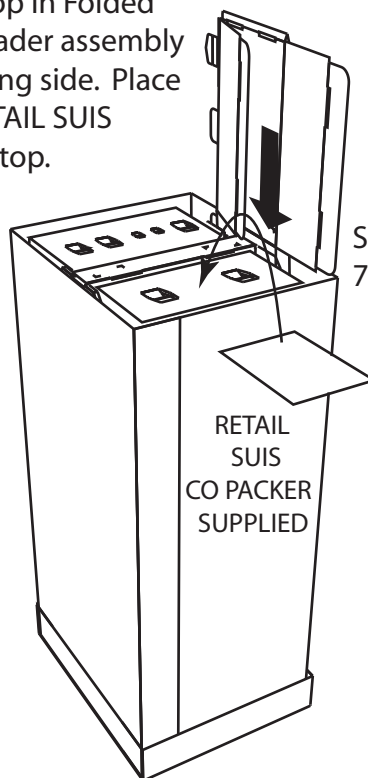

TOP/BOTTOM CAP (2)  
74185.02

SHROUD X1  
74185.01

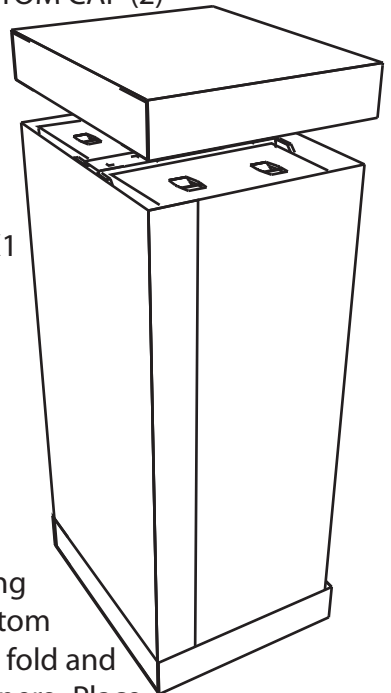

### 37.

Locate remaining Top/Bottom Cap and fold and glue corners. Place down over unit and tape to seal.

# Factory Assembly Instructions for: TYLENOL UR SHOPPABLE QTR Promo # 74185

16" BANDING PADS X4  
CO PACKER SUPPLIED

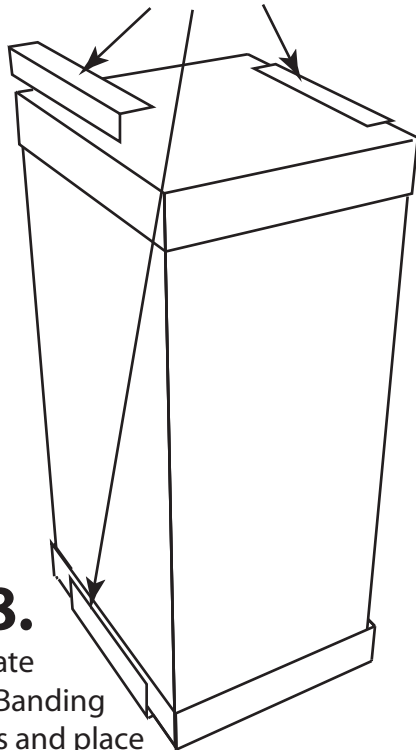

**38.**

Locate  
16" Banding  
Pads and place  
on 24" edges, top  
and bottom.

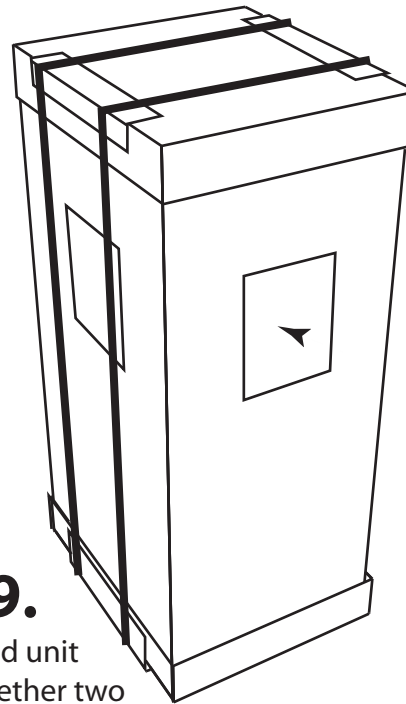

**39.**

Band unit  
together two  
times as shown. Apply  
DAY GLO Labels to all four sides.

DAY GLO  
LABELS X4  
74185.37

32" BANDING PADS X2  
CO PACKER SUPPLIED

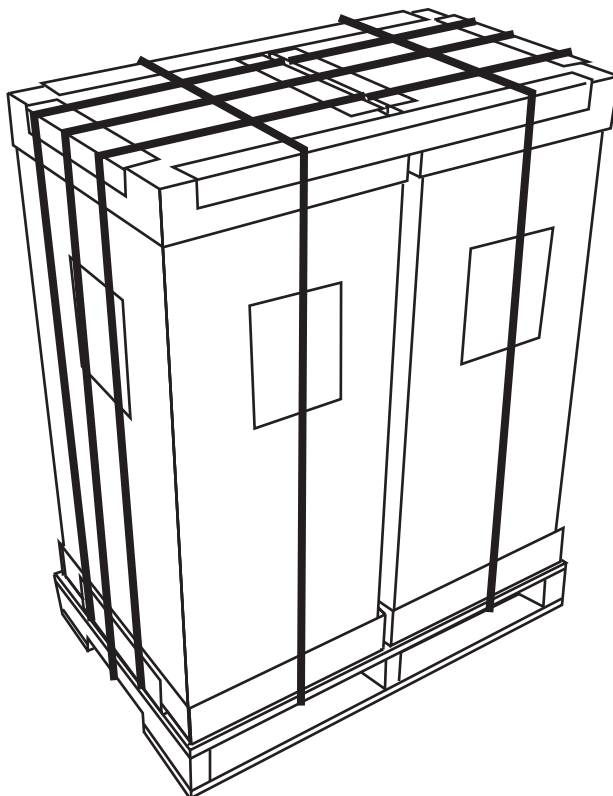

**40.**

Place two banded  
units onto half pallet.  
Place 32" Banding Pads  
along top lengths to  
appear as shown. Band  
twice along 40" length  
and once along 24" length.  
Stretch wrap unit well.