

ITEM NO.	PART NUMBER	DESCRIPTION	main design benchmade/QTY.
1	MAIN BASE		1
2	UPPER SLIDE	SP 4140 STEEL	1
3	(benchmadeknife)		1
4	(THREADED BELL)	ALREADY MADE	1
5	SHAFT KNIFE	SP 4140 STEEL	1
6	ROLL PIN FOR SHAFT	SPRING STEEL	1
7	HOLDPLATE	SP 4140 STEEL	2
8	1/2" - 20 GRADE 8 BOLTS	FULL THREAD	4
9	WASHER	MAY NOT NEED	4
10	EXTRA END FOR BASE		1
11	1/2" - 20 x 3" BOLT	HEX HEAD, MAY NEED LOCK WASHER	1

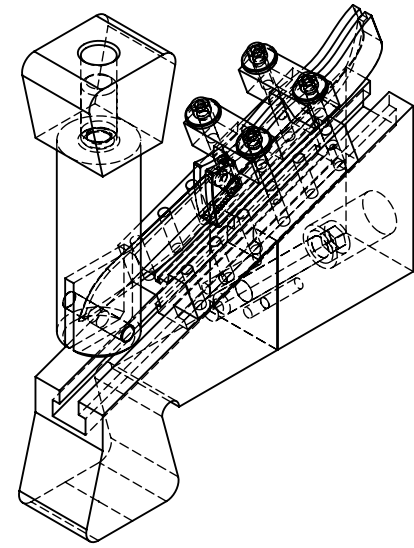
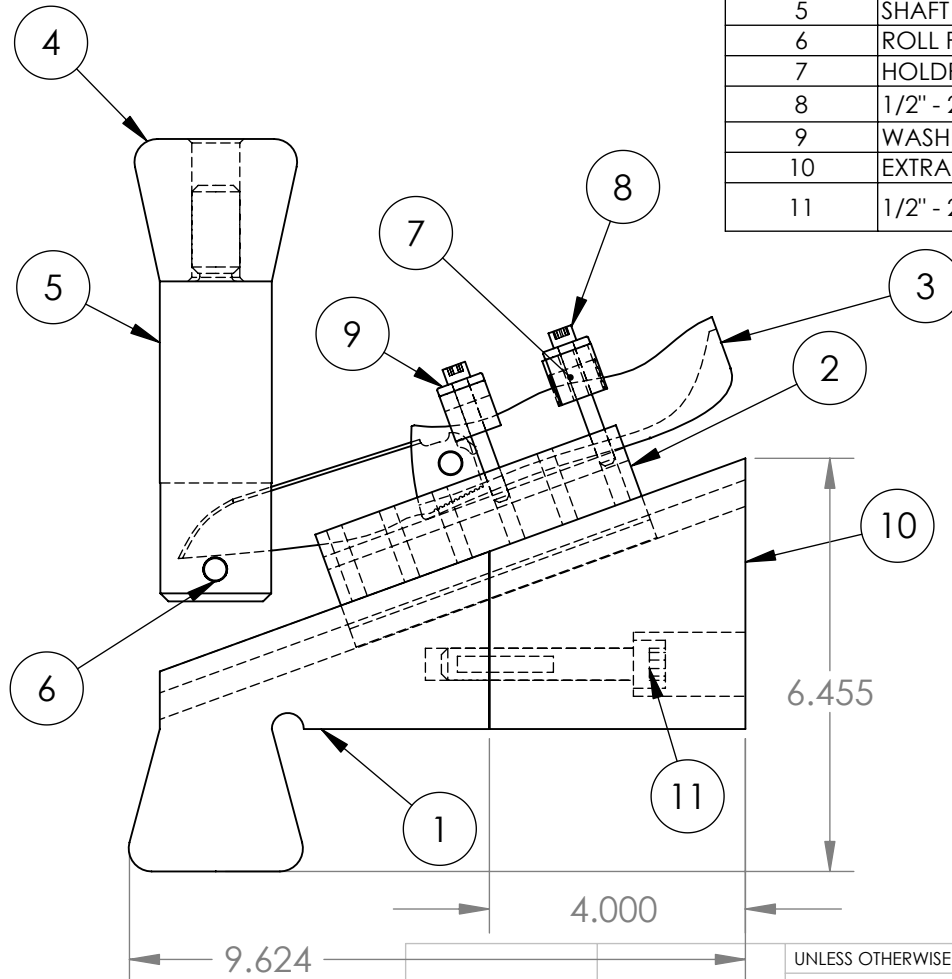

**PROPRIETARY AND CONFIDENTIAL**  
 THE INFORMATION CONTAINED IN THIS DRAWING IS THE SOLE PROPERTY OF <INSERT COMPANY NAME HERE>. ANY REPRODUCTION IN PART OR AS A WHOLE WITHOUT THE WRITTEN PERMISSION OF <INSERT COMPANY NAME HERE> IS PROHIBITED.

UNLESS OTHERWISE SPECIFIED:		NAME	DATE
DIMENSIONS ARE IN INCHES		DRAWN	ERC
TOLERANCES:		CHECKED	
FRACTIONAL ±		ENG APPR.	
ANGULAR: MACH ± BEND ±		MFG APPR.	
TWO PLACE DECIMAL ±		Q.A.	
THREE PLACE DECIMAL ±		COMMENTS:	
INTERPRET GEOMETRIC TOLERANCING PER:			
MATERIAL			
FINISH			
NEXT ASSY	USED ON		
APPLICATION			
DO NOT SCALE DRAWING			

TITLE:		
LOCKBREAKERAssem1		
SIZE	DWG. NO.	REV
<b>A</b>		<b>C</b>
SCALE: 1:8	WEIGHT:	SHEET 1 OF 1