

Front

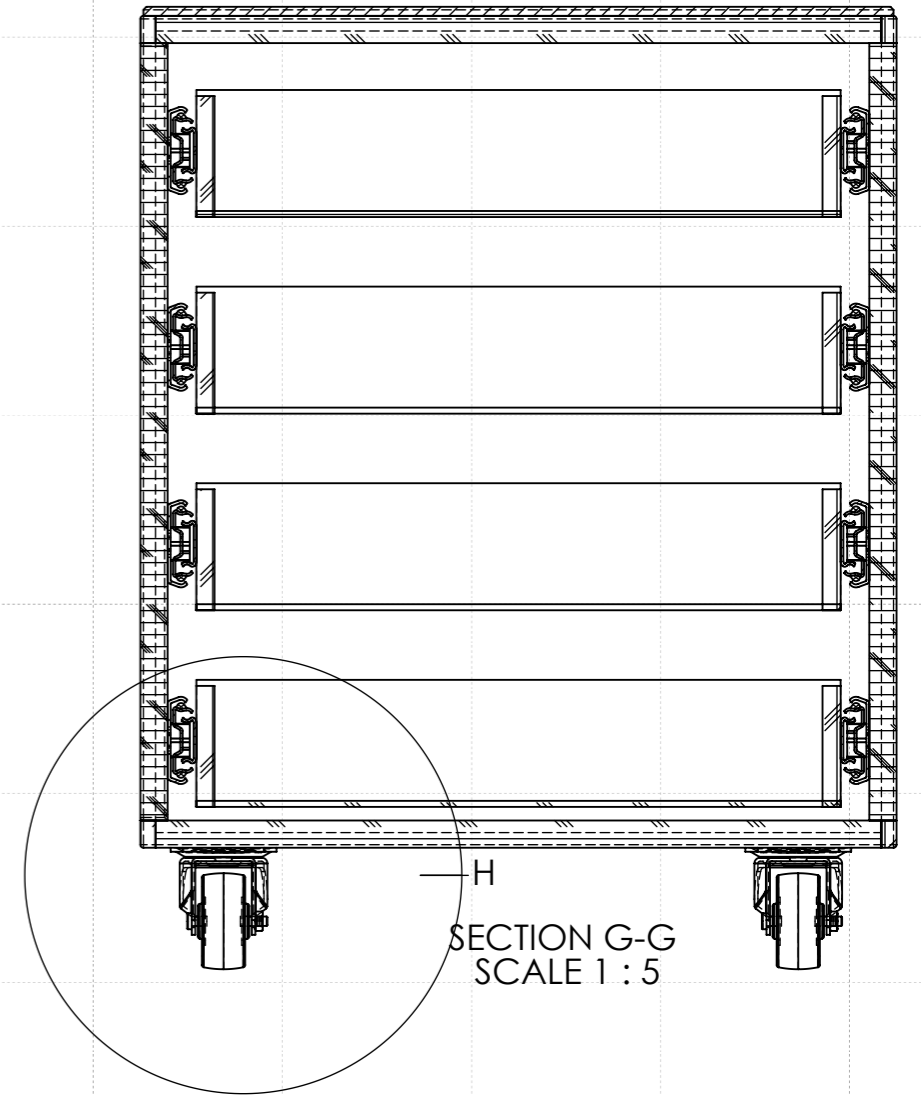

Side



SECTION G-G
SCALE 1 : 5

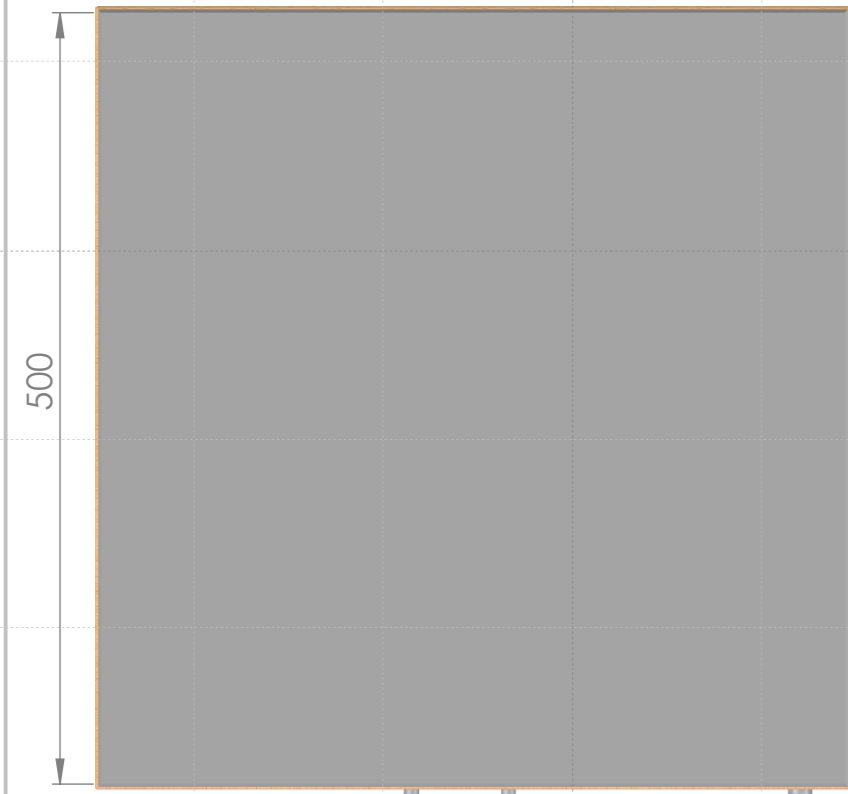

Top

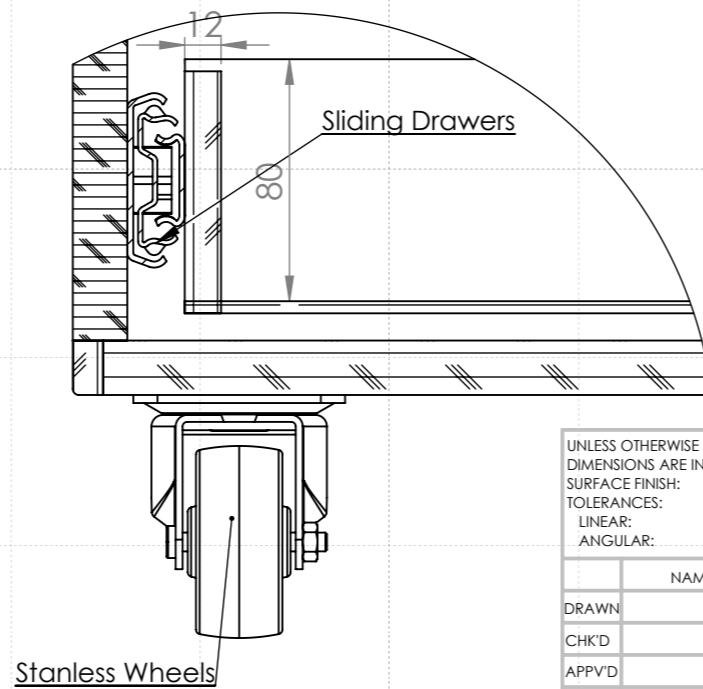

DETAIL H
SCALE 2 : 5

UNLESS OTHERWISE SPECIFIED: DIMENSIONS ARE IN MILLIMETERS SURFACE FINISH: TOLERANCES: LINEAR: ANGULAR:				FINISH:	DEBUR AND BREAK SHARP EDGES	DO NOT SCALE DRAWING	REVISION
DRAWN	NAME	SIGNATURE	DATE			TITLE: Ref_2_Drawers	
CHK'D							
APPV'D							
MFG							
Q.A				MATERIAL: beech massive, Oak sheets		DWG NO.:	Dawers
				WEIGHT:		SCALE:1:10	A3
						SHEET 1 OF 1	