

INSERT ALUMINUM PIN

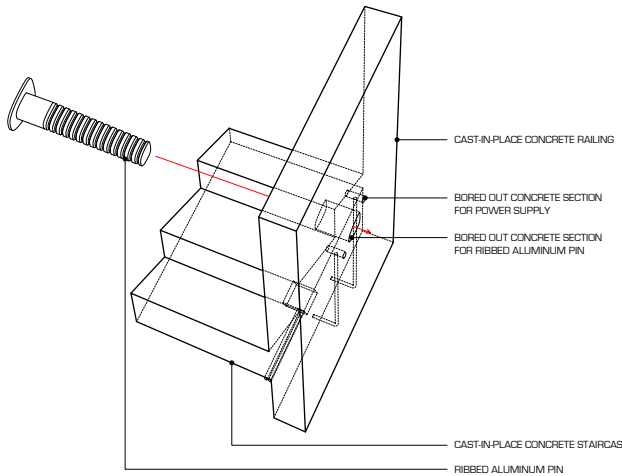

SLIDE HOLLOWED ARM ON PIN

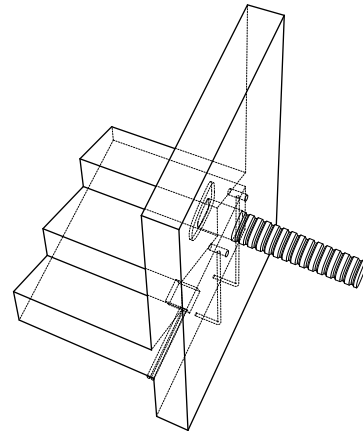

THREAD POWER + LIGHT SOURCES/  
EMPREGNATE CAVITY BETWEEN PIN AND  
ARM WITH EPOXY

