

(A) HEAD

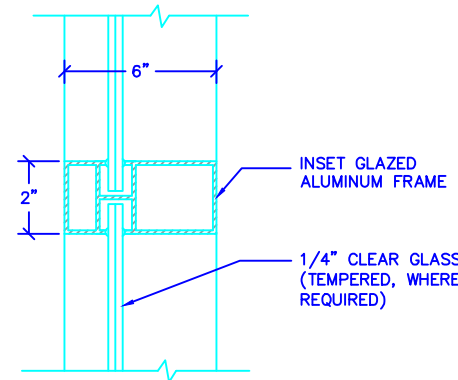

(B) MULLION

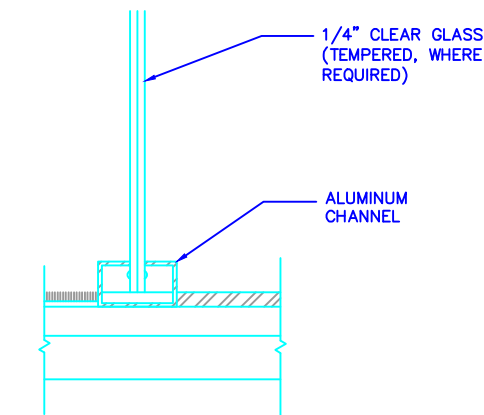

(C) SILL

DETAIL (2)

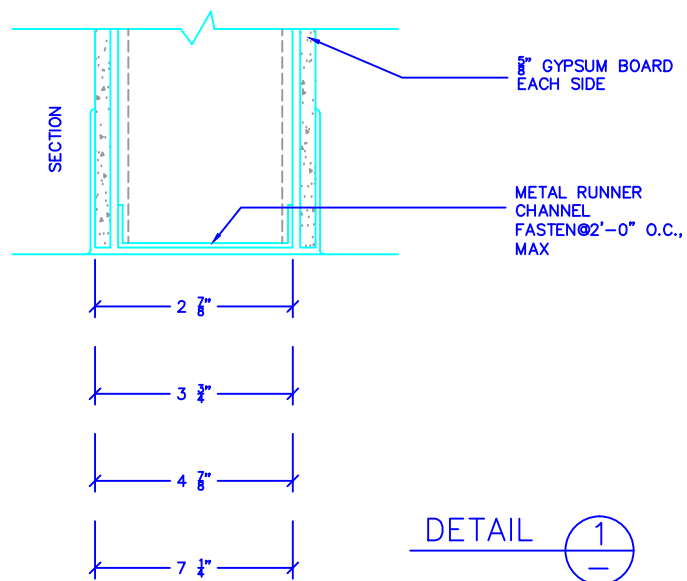
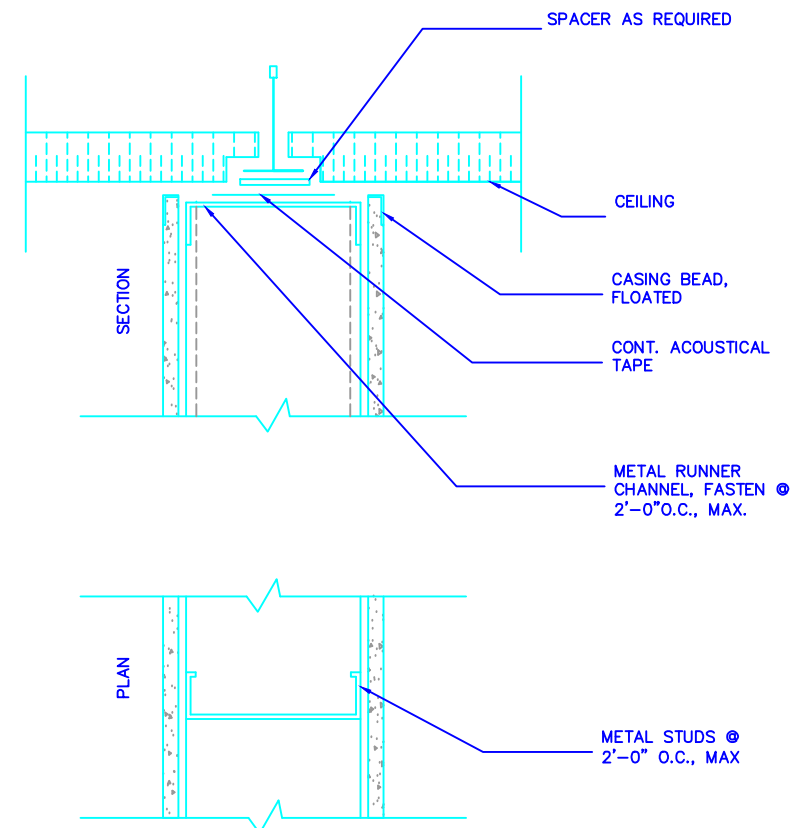

DETAIL (1)

TYPICAL CONCEALED STOREFRONT (OFFICES, CONFERENCE ROOMS)

TYPICAL NON-FIRE RATED PARTITION

NOTE:
 DUE TO TENANT IMPROVEMENT PROJECT:
 -CEILING IS INSTALLED PRIOR TO INSTALLATION OF PARTITIONS
 -HARD OFFICES ARE ALL NON-RATED
 -OFFICE STOREFRONTS & WALLS USUALLY ARE REMODELED 2 TO 3X /YEAR

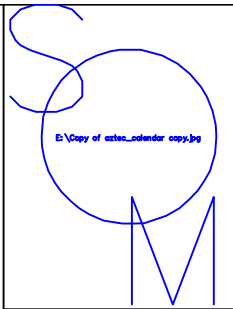

INT.404
 20WEST 7th STREET
 UPLAND, CA 91786

SHEET NAME

PARTITION DETAILS

SCALE
 N.T.S.

DRAWN BY
 Sulpisio Medrano

DATE
 4/15/09

SHEET#

404.6