



FIVE BELOW ELECTRONICS DISPLAY "H" ASSEMBLY REV .01

CUSTOMER APPROVAL

NAME: _____

DATE: _____

 <small>8160 S.W. MACDONALD, PORTLAND, OR 97225 PHONE 503.237.1818 www.grand-benedicts.com</small>	DESIGNED BY:	DATE DRAWN	CLIENT	JOB NAME	PART NUMBER	REV.
	BEN N	02.26.13	FIVE BELOW	ELECTRONICS DISPLAY	"H" ASSEMBLY	REV .01
<p>PROPRIETARY AND CONFIDENTIAL</p> <p><small>ALL RIGHTS RESERVED. ANY REPRODUCTION WITHOUT THE WRITTEN CONSENT OF GRAND-BENEDICTS IS STRICTLY PROHIBITED.</small></p> <p><small>NOTICE: THESE PLANS ARE NOT STAMPED BY AN ENGINEER OR ARCHITECT. LOCAL BUILDING CODE AND/OR OTHER APPLICABLE LAWS, CODES, RULES OR ORDINANCES MAY REQUIRE THESE PLANS TO BE STAMPED BY AN ENGINEER AND/OR ARCHITECT PRIOR TO RECEIPT OF A BUILDING PERMIT. OWNER, CONTRACTORS, AND/OR AGENTS ARE SOLELY RESPONSIBLE FOR OBTAINING SUCH STAMPS.</small></p> <p><small>ALL INFORMATION ON THESE PLANS SHOULD BE VERIFIED BY OWNER AND/OR ITS CONTRACTORS OR AGENTS AS TRUE AND CORRECT PRIOR TO THE COMMENCEMENT OF CONSTRUCTION. THE DESIGNER OF THESE PLANS MAKES NO REPRESENTATION OR WARRANTY REGARDING THESE PLANS AND THE OWNER ACKNOWLEDGES THAT THE DESIGNER HEROF AND THEREOF SHALL NOT IN ANY WAY BE LIABLE FOR, OR WITH RESPECT TO, THE SUITABILITY OF THESE PLANS. FOR OWNER'S AND/OR ITS CONTRACTORS' OR AGENTS' ACTUAL OR INTENDED USE OR FOR ANY USE WHATSOEVER OR COMPLIANCE WITH ANY APPLICABLE FEDERAL, STATE, OR LOCAL LAW, CODE, RULE OR ORDINANCE.</small></p>						
						SHEET 1 OF 3

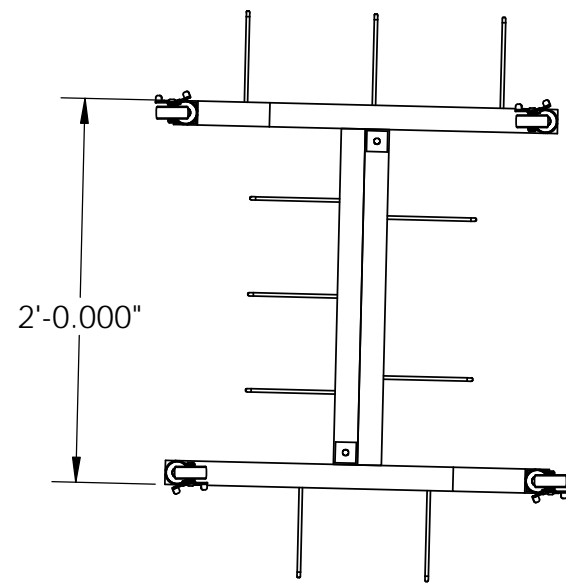
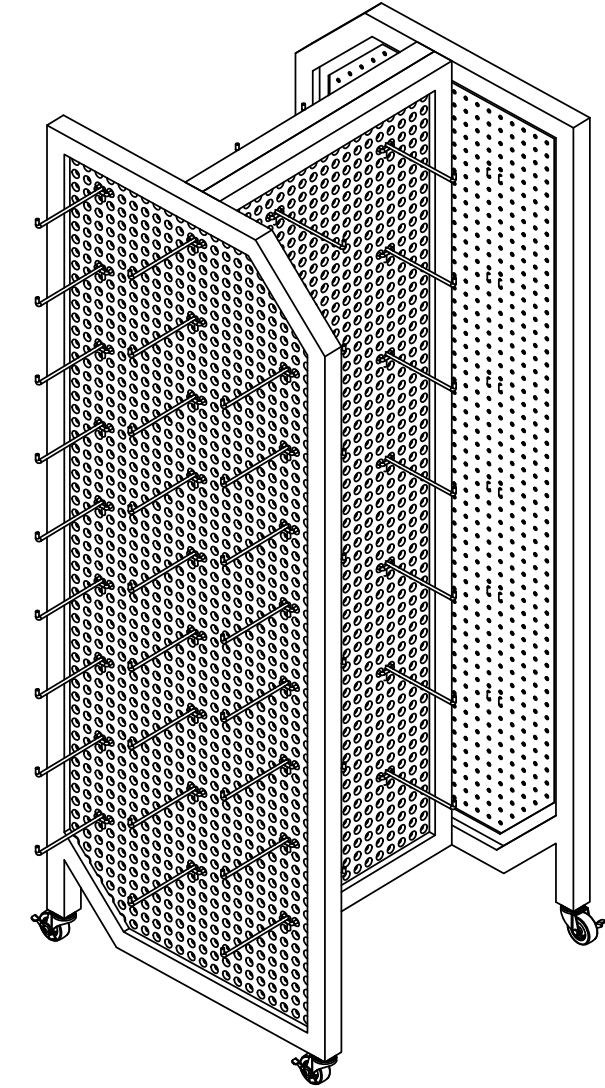
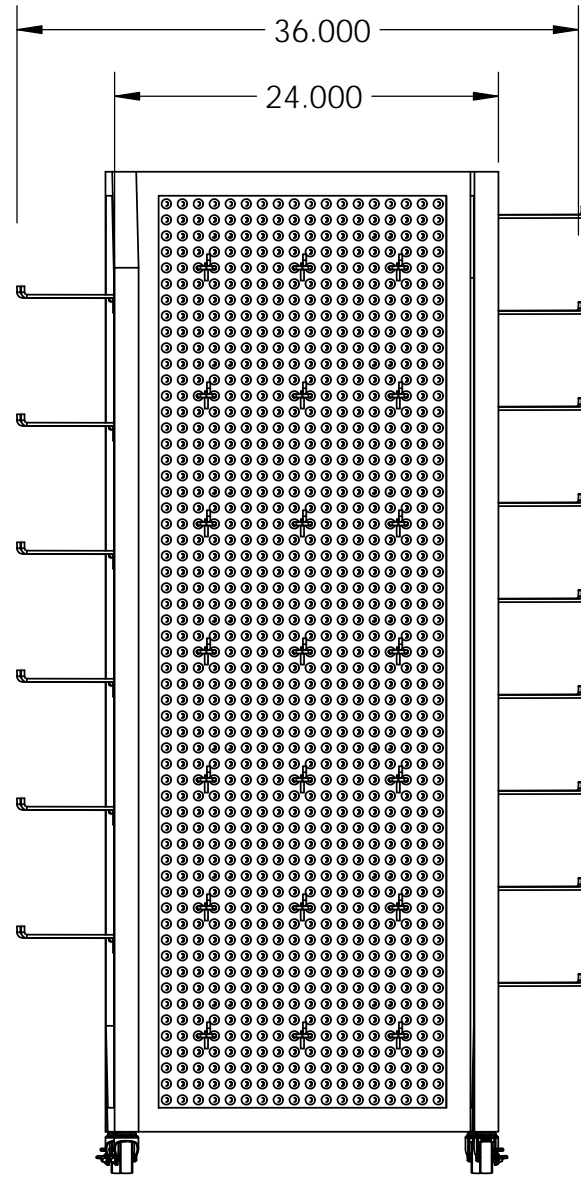
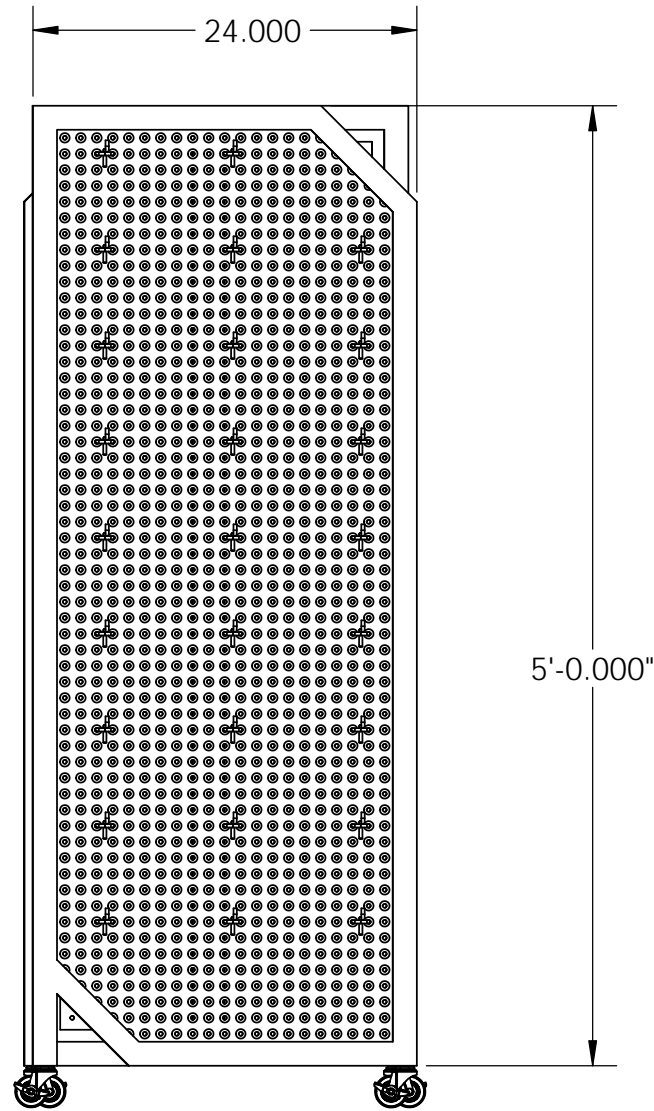

8140 S.W. MACADAM, PORTLAND, OR 97225
 PHONE 503.321.1188
 WWW.GRAND-BENEDICTS.COM

DESIGNED BY:	DATE DRAWN	CLIENT	JOB NAME	PART NUMBER	REV.
BEN N	02.36.13	FIVE BELOW	ELECTRONICS DISPLAY	"H" ASSEMBLY	REV .01

PROPRIETARY AND CONFIDENTIAL

ALL RIGHTS RESERVED. ANY REPRODUCTION WITHOUT THE WRITTEN CONSENT OF GRAND-BENEDICTS IS STRICTLY PROHIBITED.

NOTICE: THESE PLANS ARE NOT STAMPED BY AN ENGINEER OR ARCHITECT. LOCAL BUILDING CODE AND/OR OTHER APPLICABLE LAWS, CODES, RULES OR ORDINANCES MAY REQUIRE THESE PLANS TO BE STAMPED BY AN ENGINEER AND/OR ARCHITECT PRIOR TO RECEIPT OF A BUILDING PERMIT. OWNER, CONTRACTORS, AND/OR AGENTS ARE SOLELY RESPONSIBLE FOR OBTAINING SUCH STAMPS.

ALL INFORMATION ON THESE PLANS SHOULD BE VERIFIED BY OWNER AND/OR ITS CONTRACTORS OR AGENTS AS TRUE AND CORRECT PRIOR TO THE COMMENCEMENT OF CONSTRUCTION. THE DESIGNER OF THESE PLANS MAKES NO REPRESENTATION OR WARRANTY REGARDING THESE PLANS AND THE OWNER ACKNOWLEDGES THAT THE DESIGNER HEROF AND THEREOF SHALL NOT IN ANY WAY BE LIABLE FOR, OR WITH RESPECT TO, THE SUITABILITY OF THESE PLANS. FOR OWNER'S AND/OR ITS CONTRACTORS' OR AGENTS' ACTUAL OR INTENDED USE OR FOR ANY USE WHATSOEVER OR COMPLIANCE WITH ANY APPLICABLE FEDERAL, STATE, OR LOCAL LAW, CODE, RULE OR ORDINANCE.

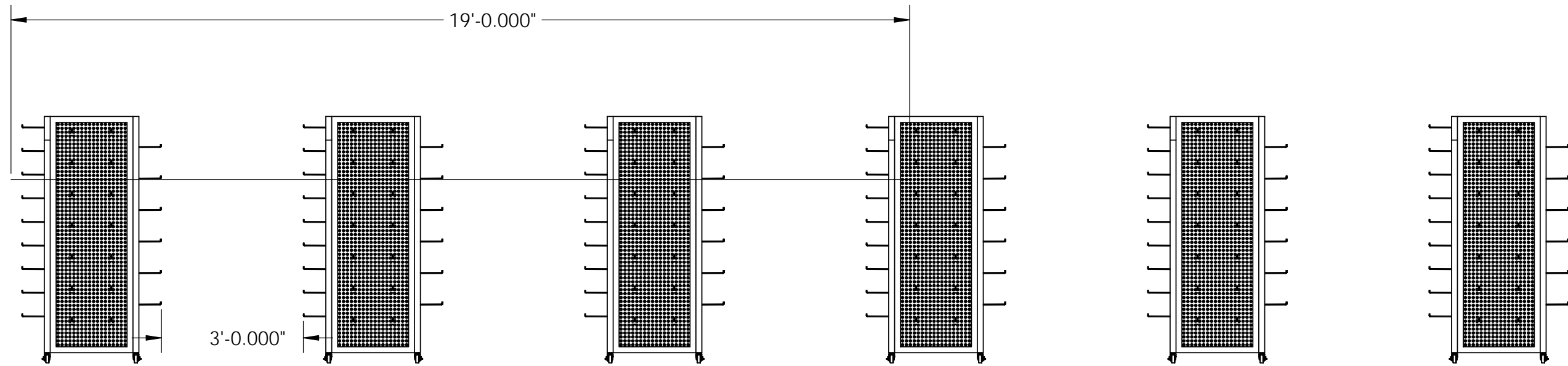

	DESIGNED BY:	DATE DRAWN:	CLIENT:	JOB NAME:	PART NUMBER:	REV.:
	BEN N	02.26.13	FIVE BELOW	ELECTRONIC DISPLAY	"H" ASSEMBLY	REV .01
<p>PROPRIETARY AND CONFIDENTIAL</p> <p>ALL RIGHTS RESERVED. ANY REPRODUCTION WITHOUT THE WRITTEN CONSENT OF GRAND-BENEDICTS IS STRICTLY PROHIBITED.</p> <p>NOTICE: THESE PLANS ARE NOT STAMPED BY AN ENGINEER OR ARCHITECT. LOCAL BUILDING CODE AND/OR OTHER APPLICABLE LAWS, CODES, RULES OR ORDINANCES MAY REQUIRE THESE PLANS TO BE STAMPED BY AN ENGINEER AND/OR ARCHITECT PRIOR TO RECEIPT OF A BUILDING PERMIT. OWNER, CONTRACTORS, AND/OR AGENTS ARE SOLELY RESPONSIBLE FOR OBTAINING SUCH STAMPS.</p> <p>ALL INFORMATION ON THESE PLANS SHOULD BE VERIFIED BY OWNER AND/OR ITS CONTRACTORS OR AGENTS AS TRUE AND CORRECT PRIOR TO THE COMMENCEMENT OF CONSTRUCTION. THE DESIGNER OF THESE PLANS MAKES NO REPRESENTATION OR WARRANTY REGARDING THESE PLANS AND THE OWNER ACKNOWLEDGES THAT THE DESIGNER HEROF AND THEREOF SHALL NOT IN ANY WAY BE LIABLE FOR, OR WITH RESPECT TO, THE SUITABILITY OF THESE PLANS. FOR OWNER'S AND/OR ITS CONTRACTORS' OR AGENTS' ACTUAL OR INTENDED USE OR FOR ANY USE WHATSOEVER OR COMPLIANCE WITH ANY APPLICABLE FEDERAL, STATE, OR LOCAL LAW, CODE, RULE OR ORDINANCE.</p>						
						SHEET
						3 OF 3