

# PORTFOLIO



**RAPHAEL FREITAS**  
Product Designer and student of  
Interface Ergodesign (Post Graduation) in PUC-Rio.



RAPHAEL  
FREITAS

CONCEPTUAL



# 1111 Mirante

Mirante

Can we celebrate  
the beauty of  
diversity some day?

RAPHAEL FREITAS



mirante

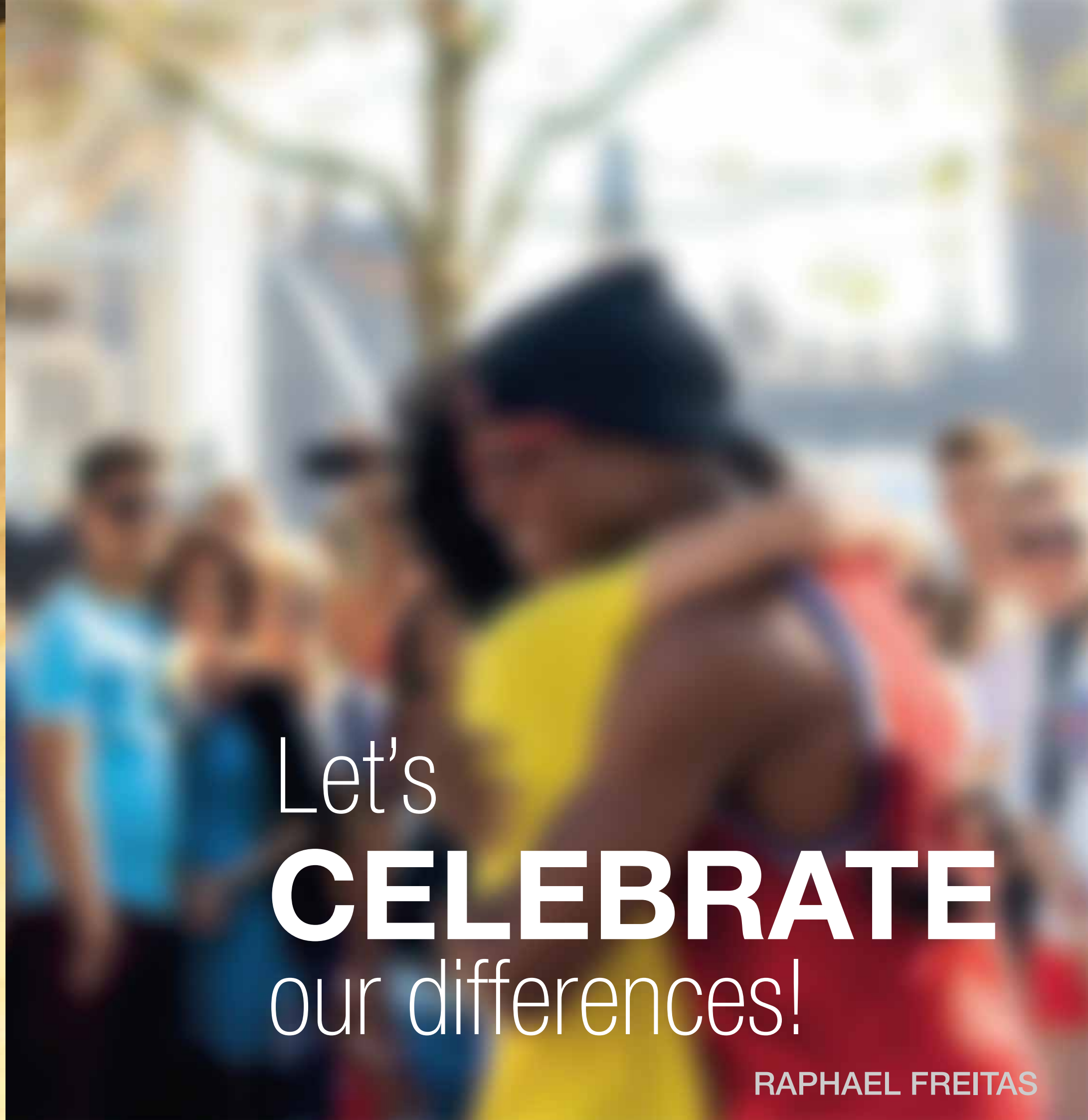

Let's  
**CELEBRATE**  
our differences!

RAPHAEL FREITAS

Mirante

REFERENCES

..and just

ENJOY!

all the moments!

Mountains and Beautiful landscapes



Interactive  
Surfaces



Theather



Observatory



Scenic Cruiser



Soft Curves



Connected Shapes

RAPHAEL FREITAS

Mirante

# EARLY SKETCHES

Hand and Photoshop Sketches

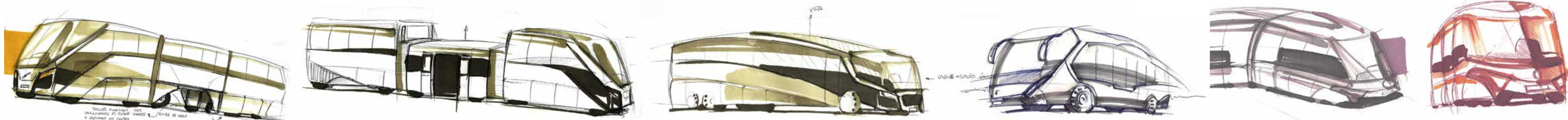
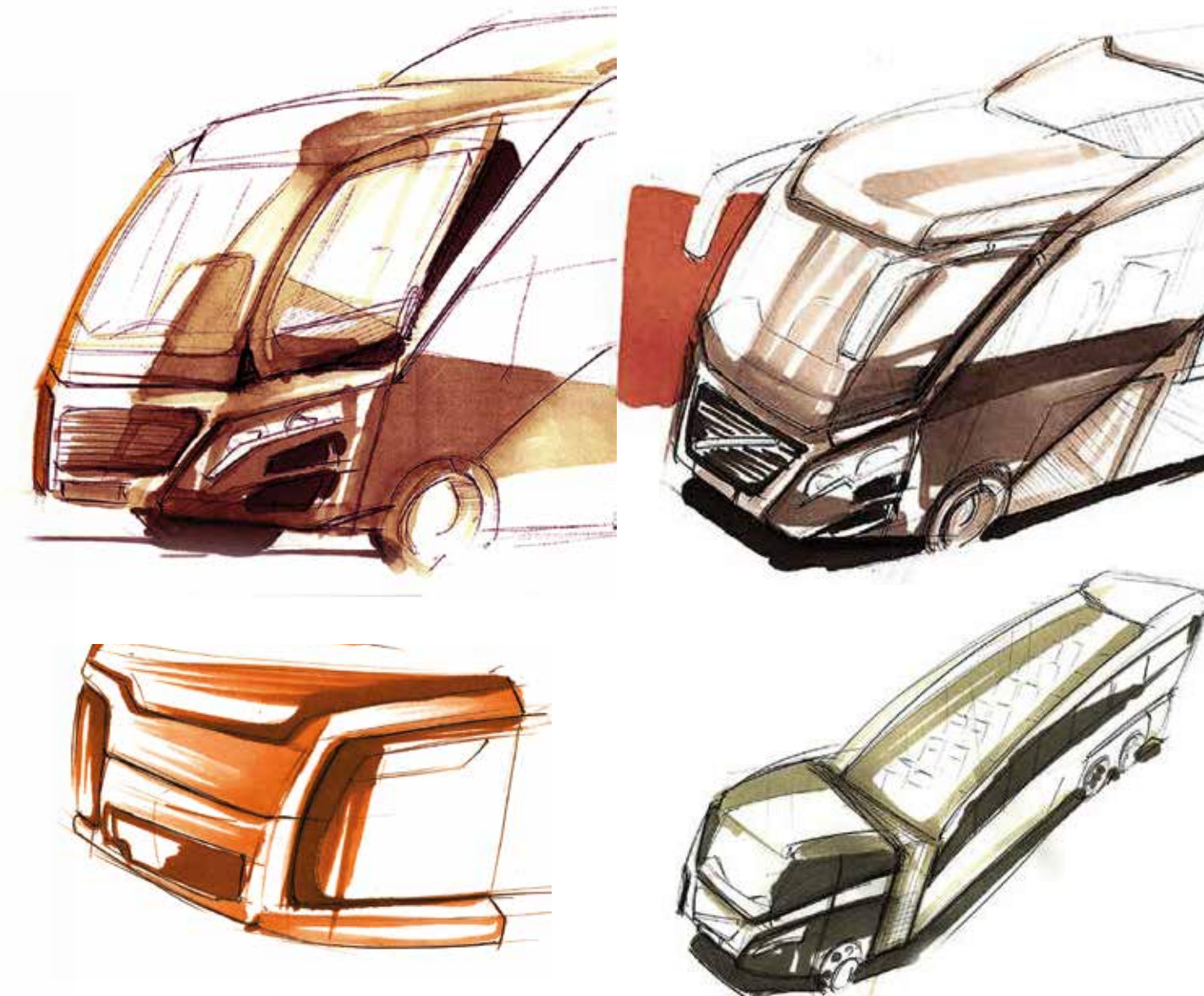
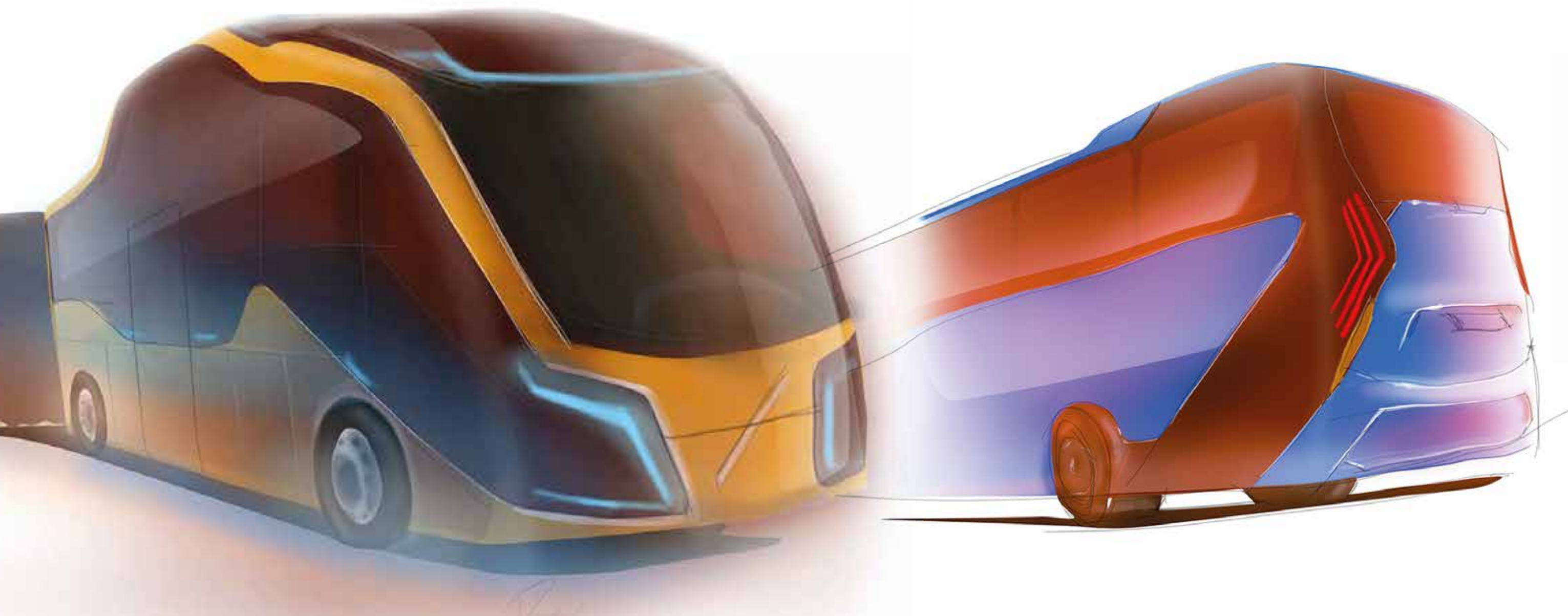

RAPHAEL FREITAS

Mirante

# FINAL SKETCHES

Photoshop Sketches



RAPHAEL FREITAS



Mirante

enjoy all the moments...  
because we are made of memories.



RAPHAEL FREITAS

MIRANTE

**MIRANTE** in portuguese means a high place to enjoy the view. It is a coach proposal based in Universal Design, celebration of diversity and enjoying the trip.

Mirante

EXTERNAL

Modeling and Rendering in 3D Max



## Dimensions

Height: 4100 mm

Length: 13200 - 14000mm

Width: 2600 mm

## Central Door

Permit independent access

## Large front Door

Placed in corner  
Comfortable access

RAPHAEL FREITAS

# Mirante **INSIDE**

Rendering of the sectors

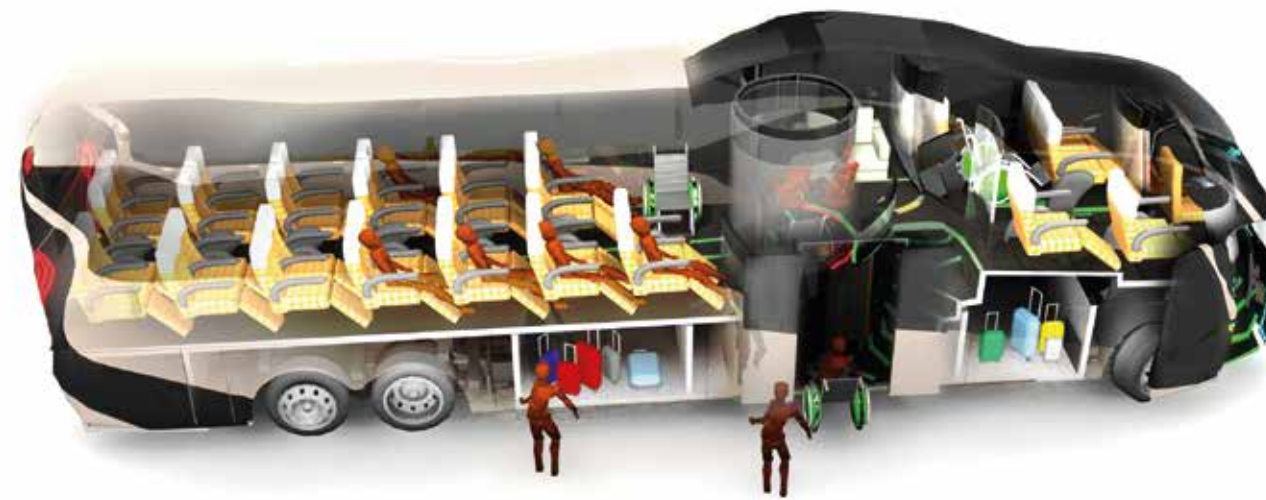

**Hall** Water, Coffee  
Elevator access  
Stairs  
Universal Toilet



**Elevator** Interactive Walls  
Open in different sides  
directly the sectors

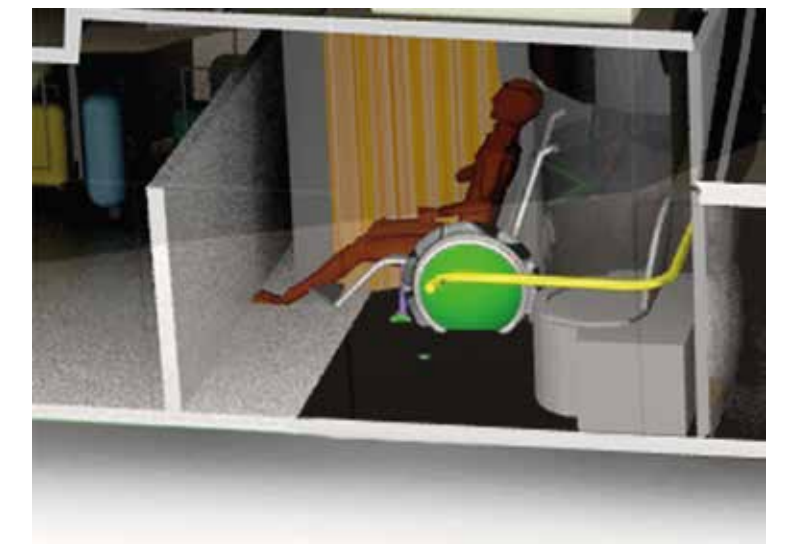
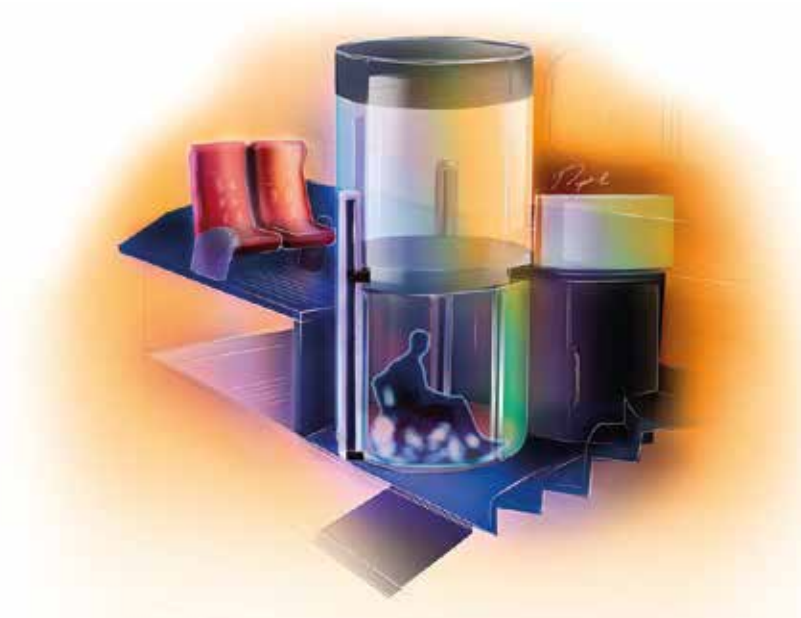

**Toilet** Universal

**RAPHAEL FREITAS**

# Mirante INSIDE

Rendering of the sectors

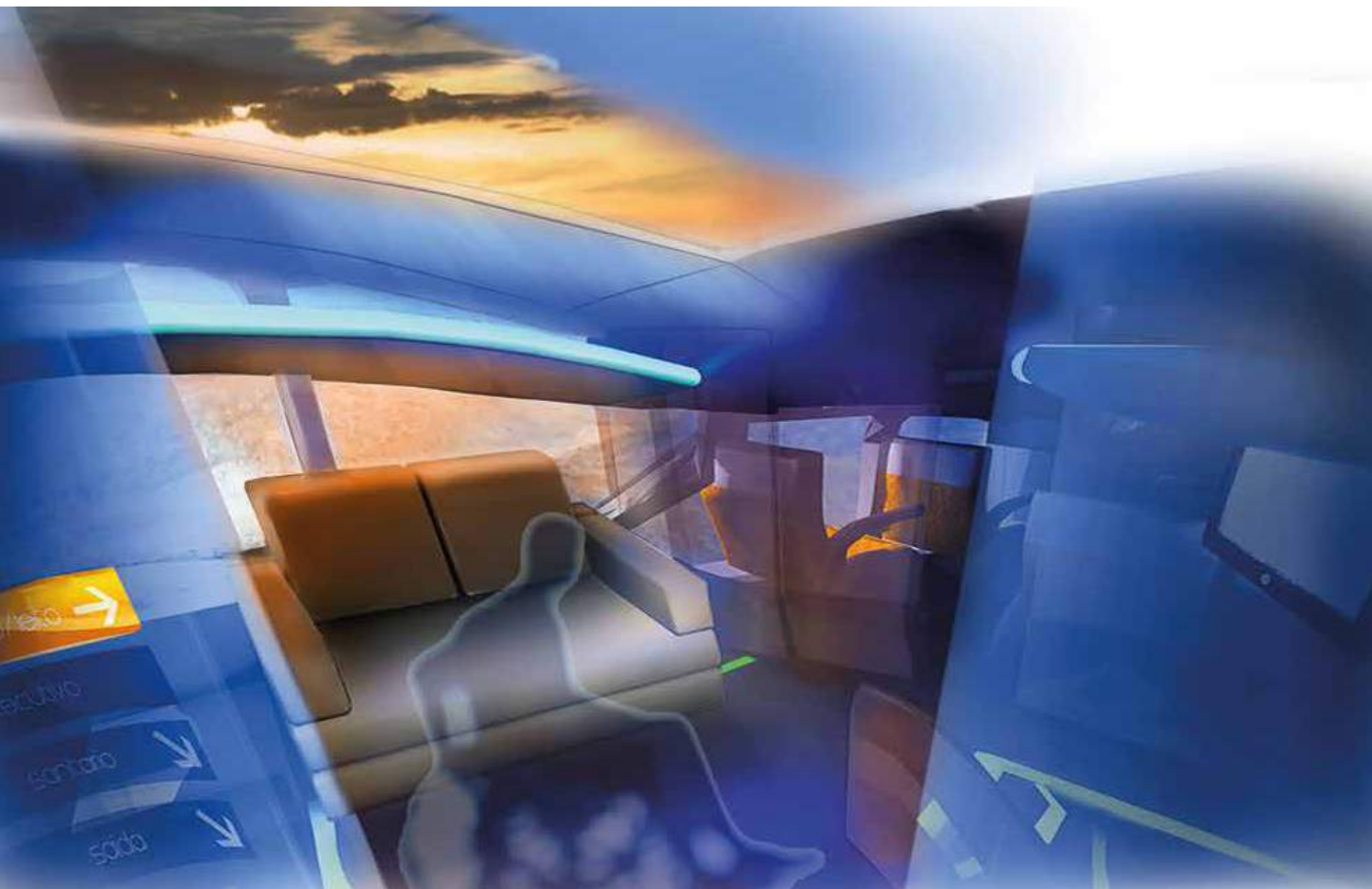
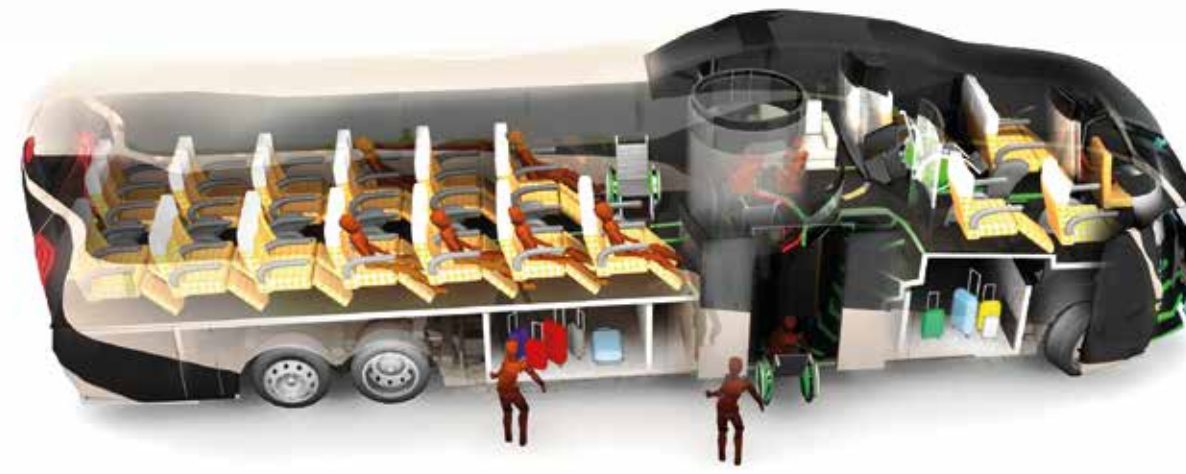

## Lounge

A room to enjoy the trip  
Entertainment  
Connect all the sectors  
Isolate the noise and clarity  
Solar roof



## Front Section

Grand Stand Form

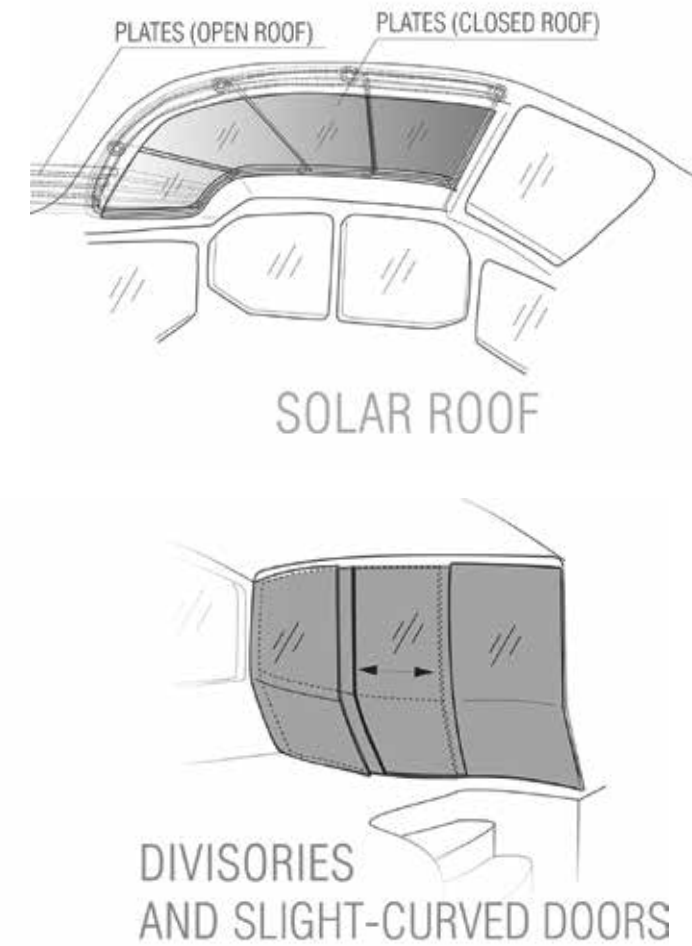

**RAPHAEL FREITAS**

Mirante

MODEL

Model in Acrylic 6mm

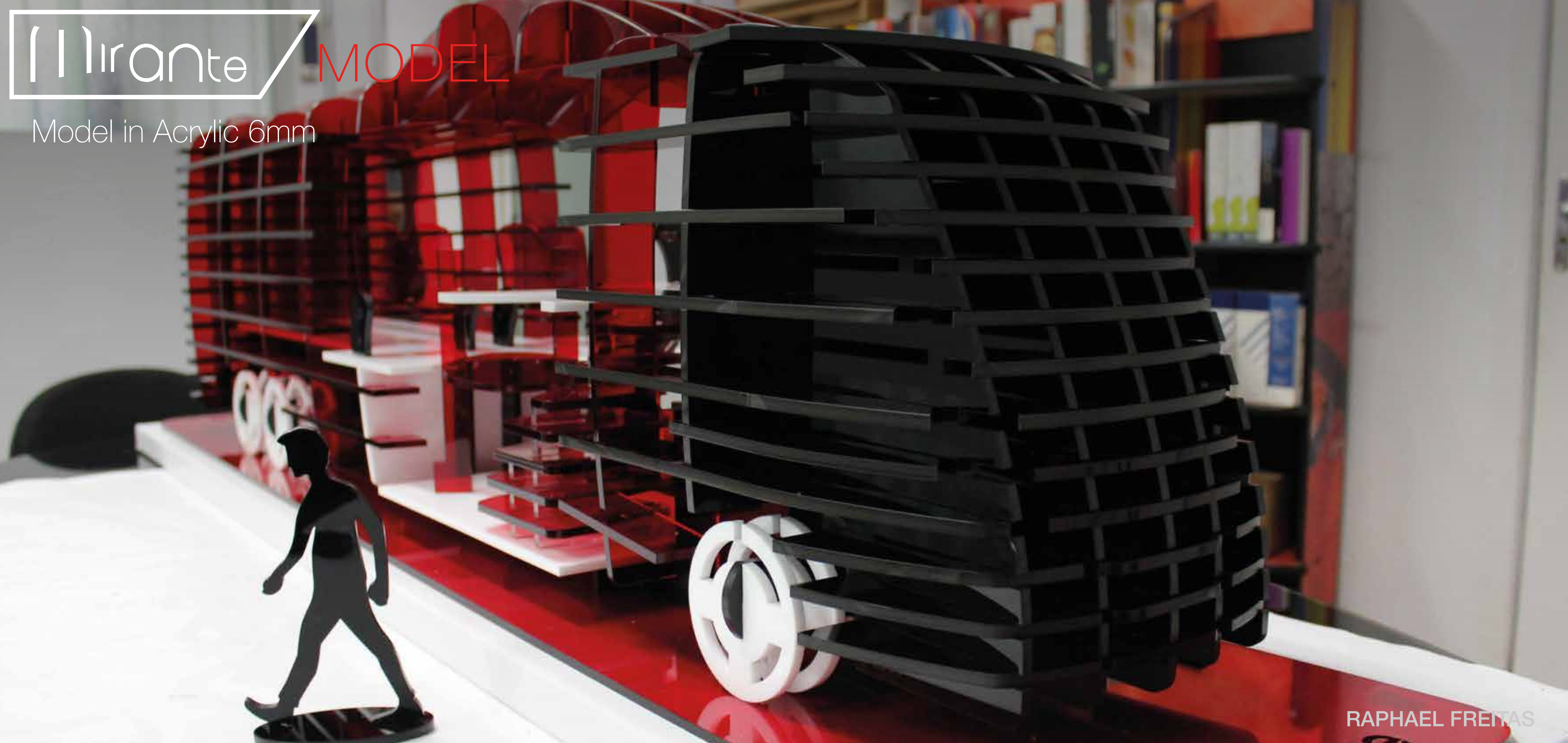

RAPHAEL FREITAS

Mirante

MODEL

Scale: 1:10



RAPHAEL FREITAS

## RE-BOARD - Stora Enso (photo)

Re-Board is a 100% recycled and recyclable material constructed by a structured layers of paper. It allows printing in various shapes, sizes and special folds and cuts. The greater benefits that it offers are the easy assembling and storing and light weight. Re-Board is disponible in 8, 10, 16 and 30 mm thickness.

## PAPER-BOARD

Paper-Board is a special kind of card-board with 3mm of thickness. It allows printing in various shapes, sizes and a diversity of folds and cuts.

RAPHAEL **COMPANY:**  
**FREITAS** ARTWORK DIGITAL

Design Team: Raphael Freitas, Alexandre Diniz, Cíntia Anacleto,  
Marcelo Duque.

RAPHAEL FREITAS



artwork  
DIGITAL  
31 - 2108.8200

artwork  
DIGITAL  
31 - 2108.8200

artwork  
DIGITAL  
31 - 2108.8200

work  
DIGITAL  
108.8200

artw  
31

K

artwor  
DIGITAL  
31 - 2108.8200

CONVEY Customer:  
INFINITY PRINT

RAPHAEL FREITAS





# CONVEY

**CONVEY** is a self-service printing totem, that offers comfortable use and ease assembly/ disassembly, transport, and maintenance.  
Material: Re-Board 16mm

RAPHAEL FREITAS

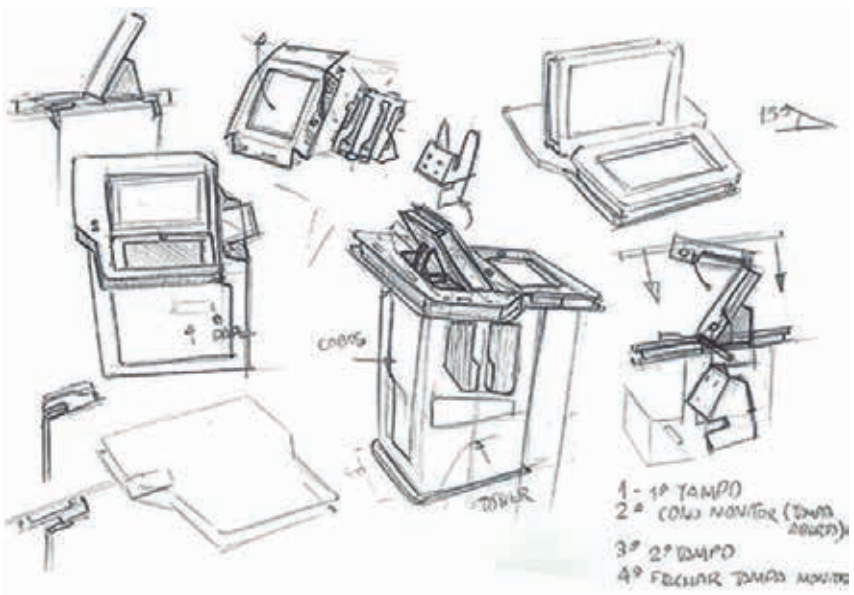
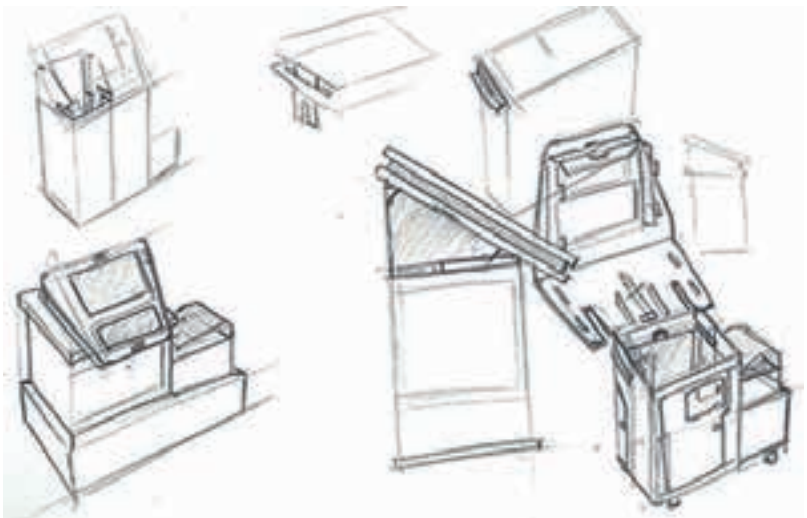
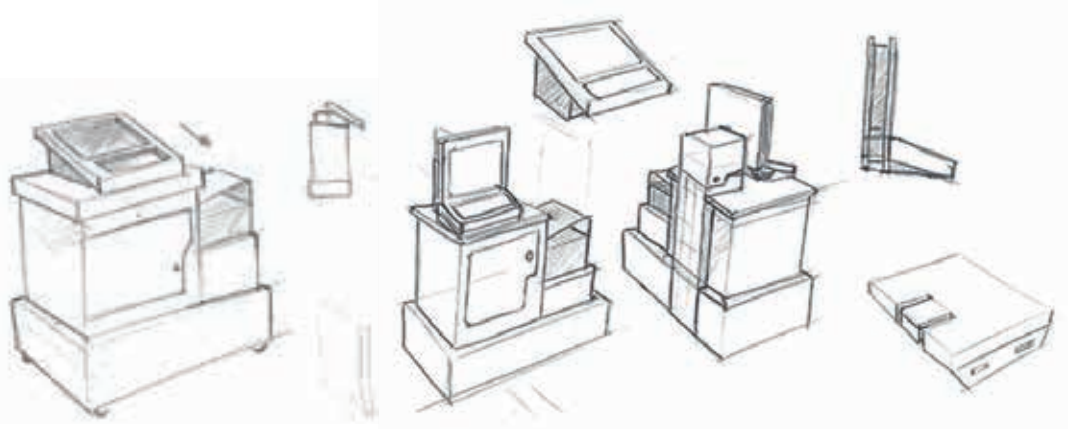

ESSA PEÇA É  
EST INTERNA CPU +  
IMPRESSORA  
2B - DEPOIS

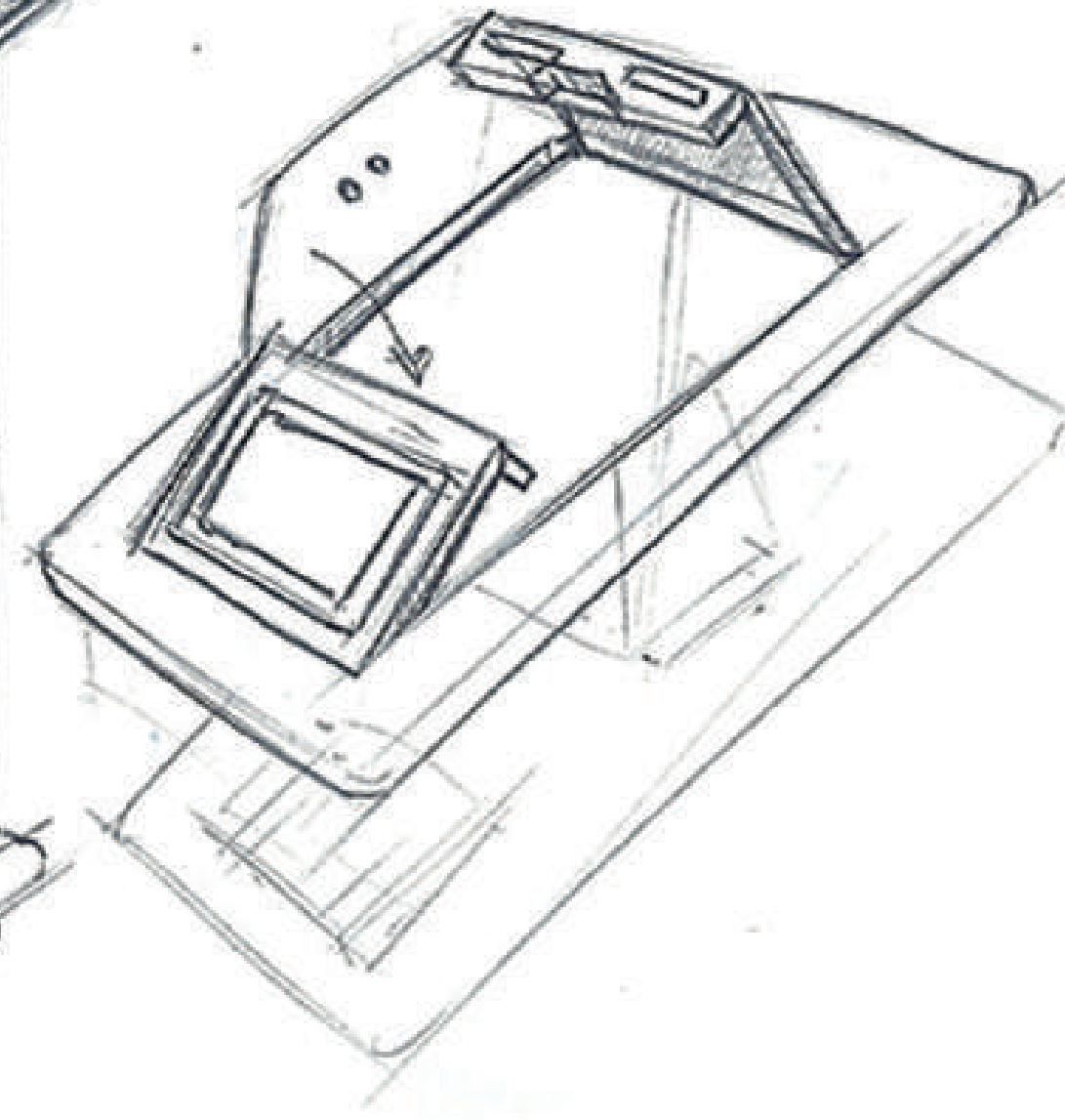
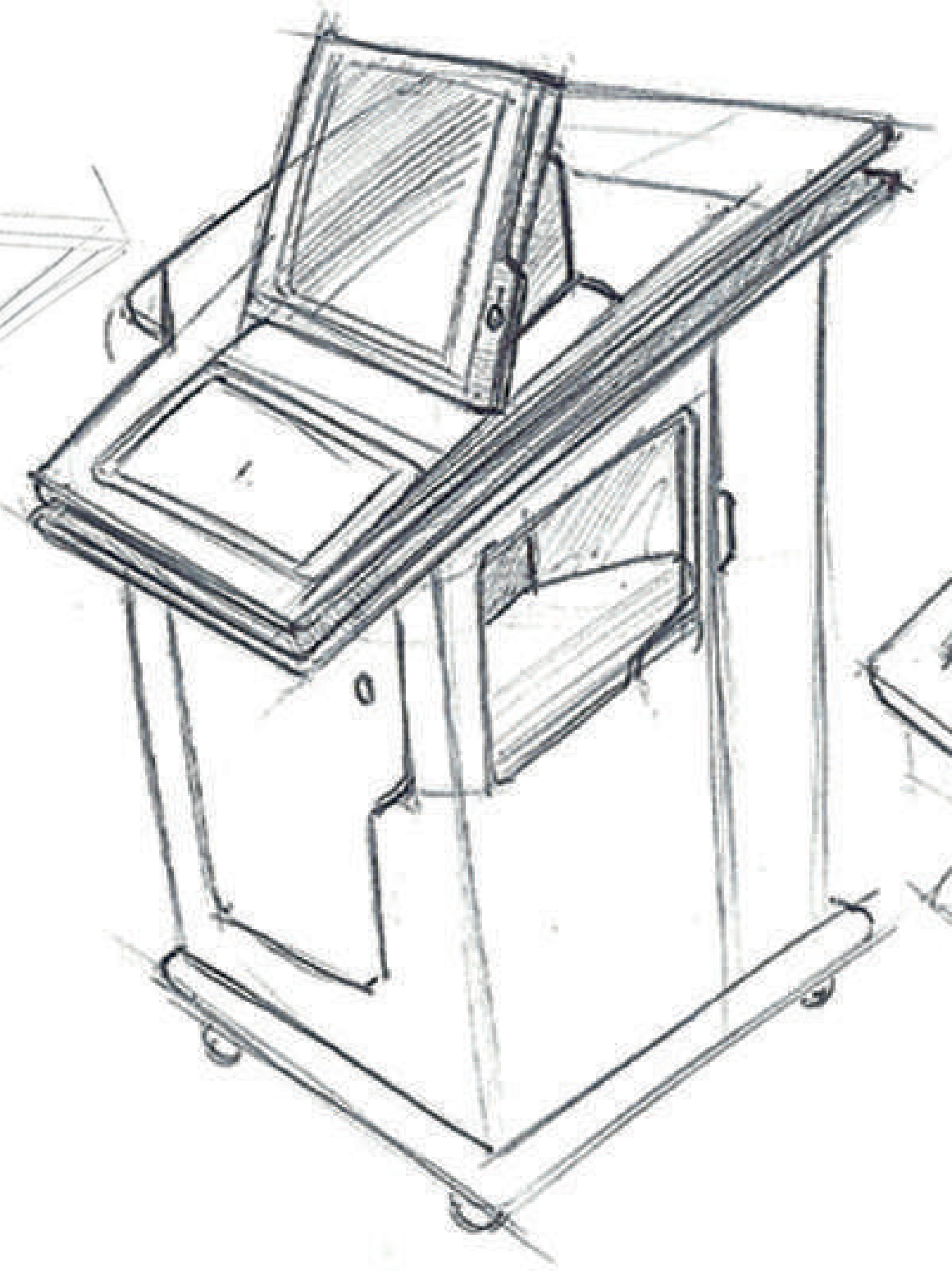
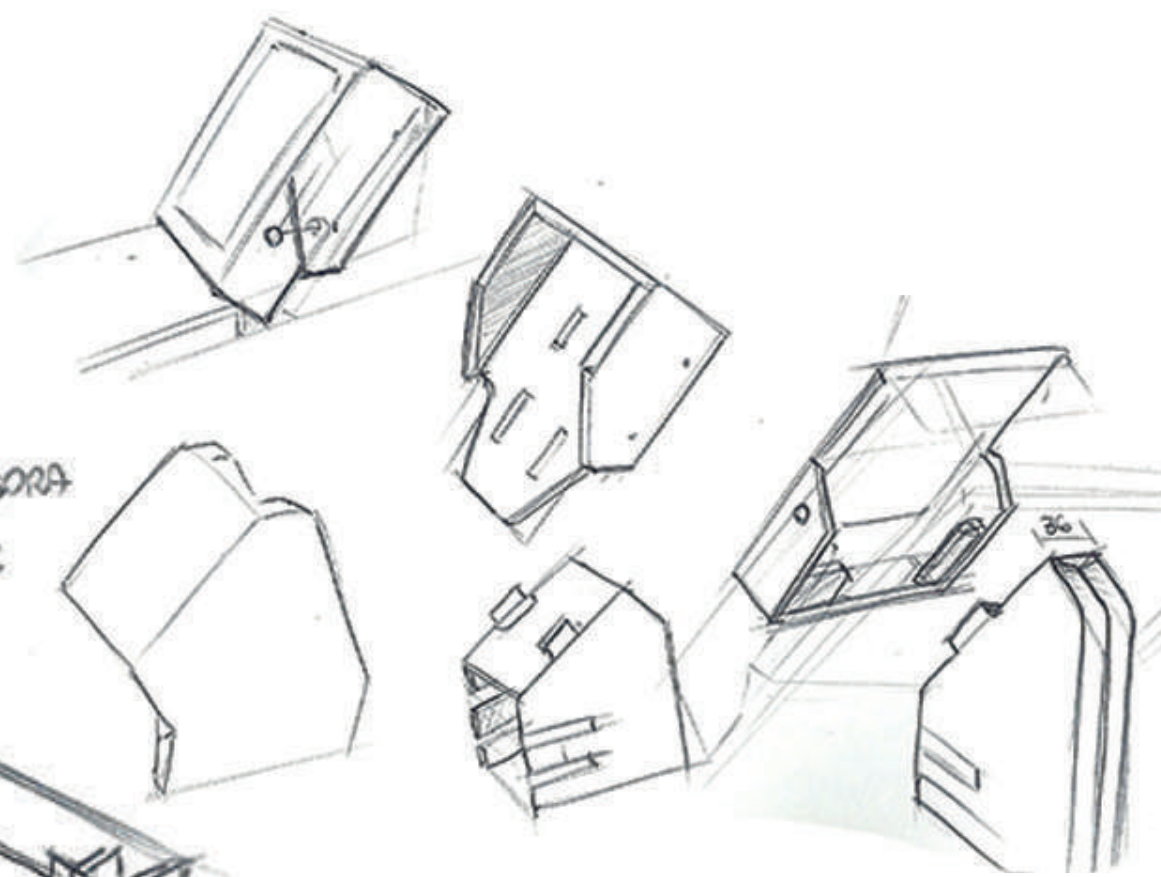
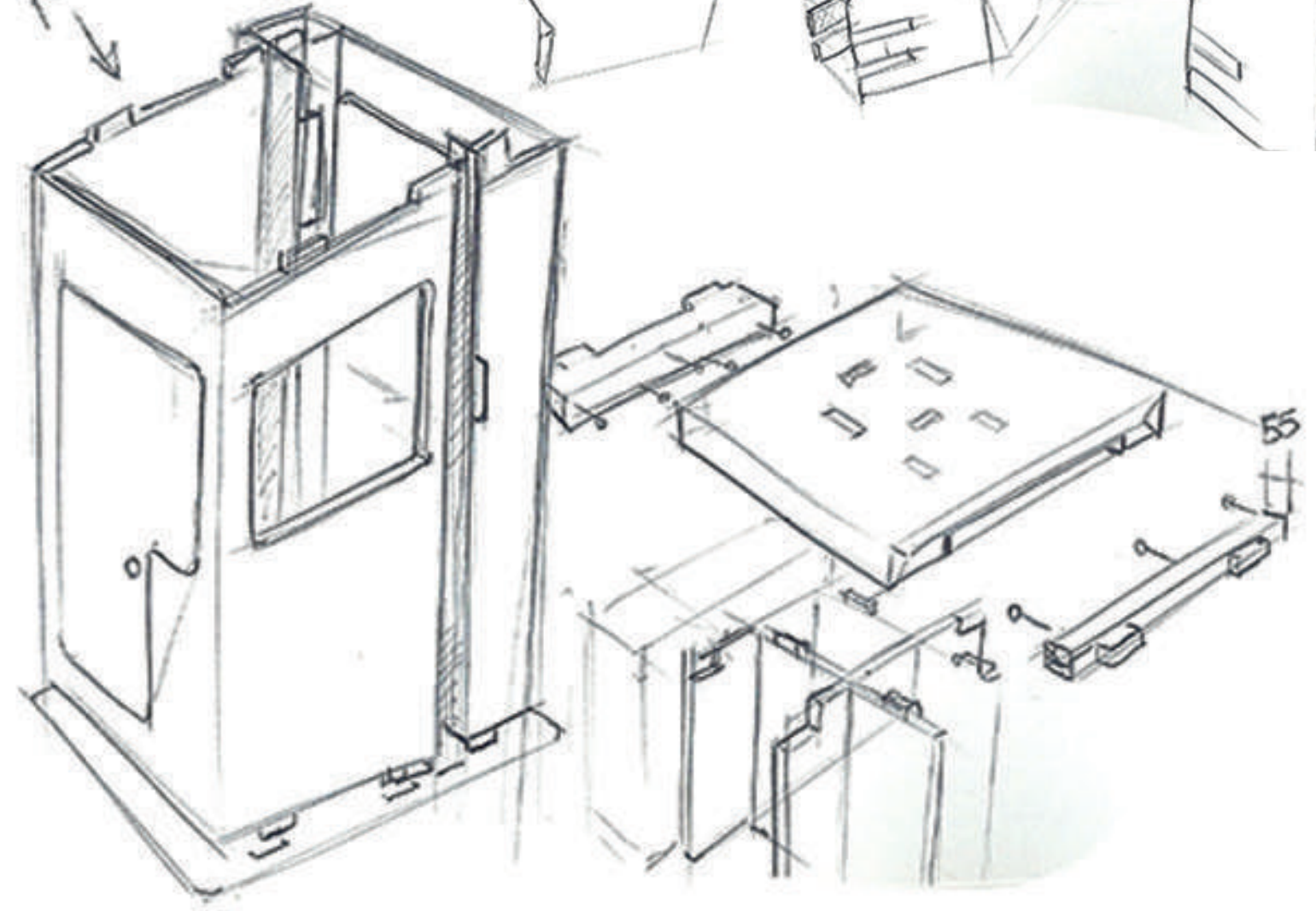

RAPHAEL FREITAS

# CONVEY

Sketches and ideas

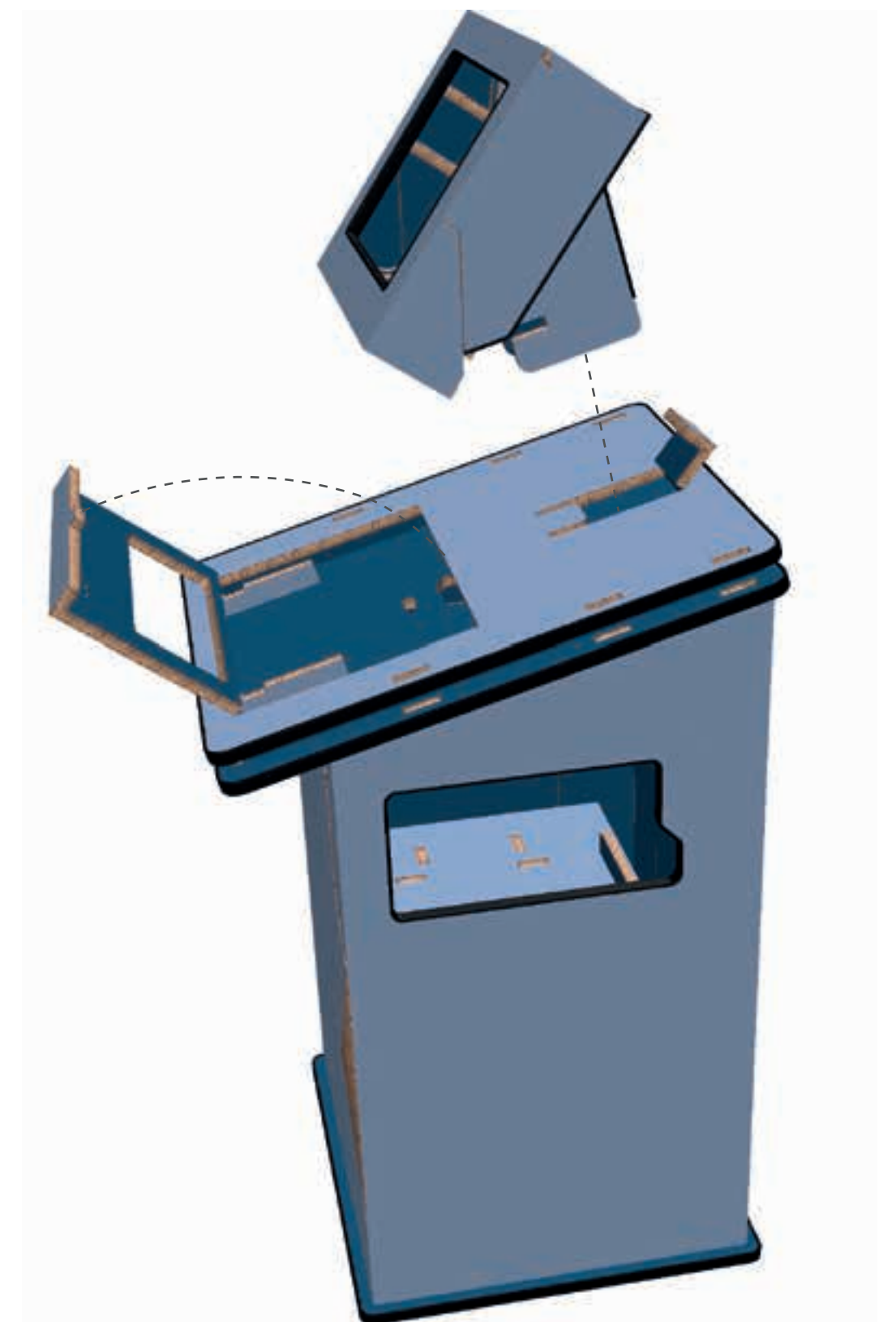
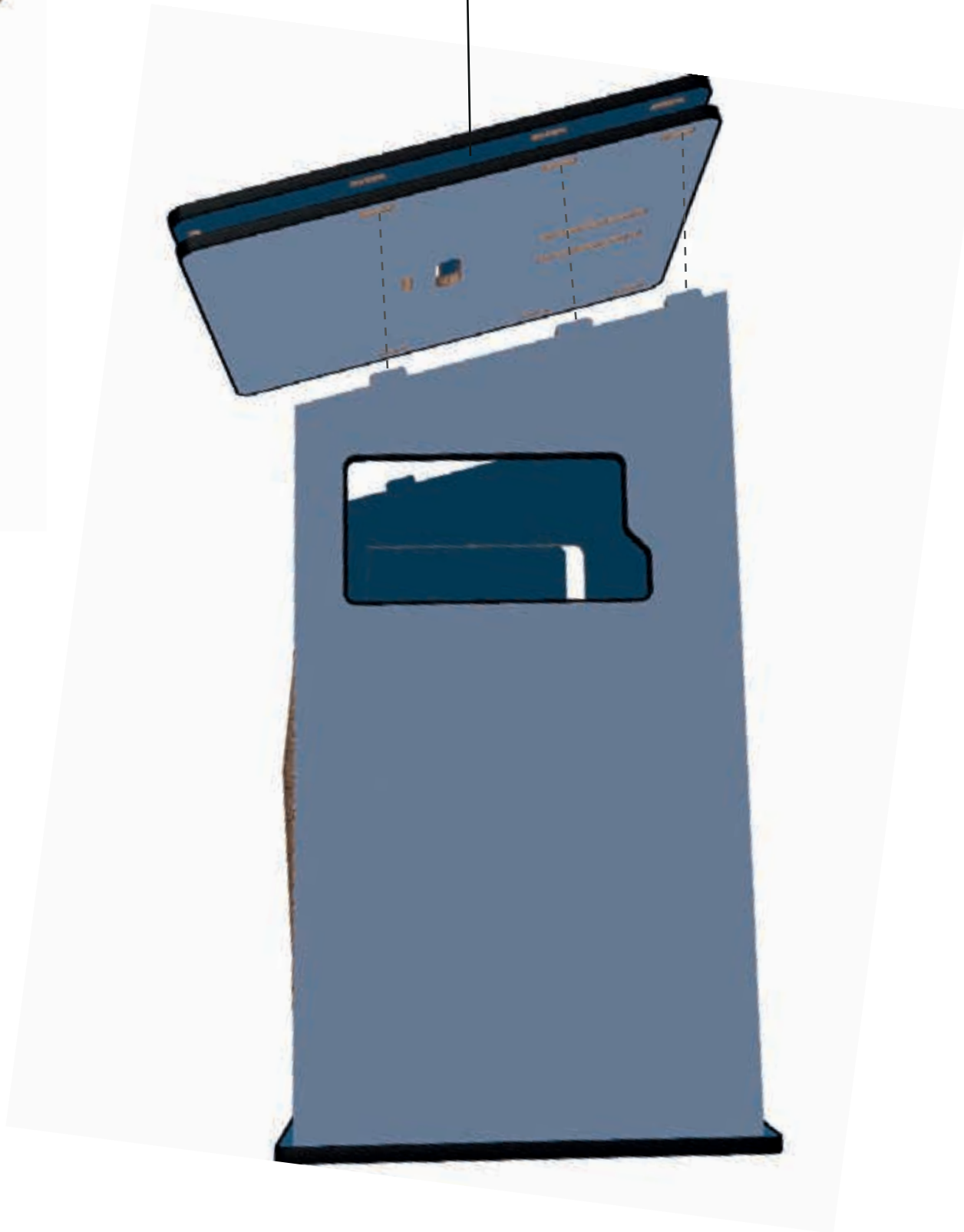
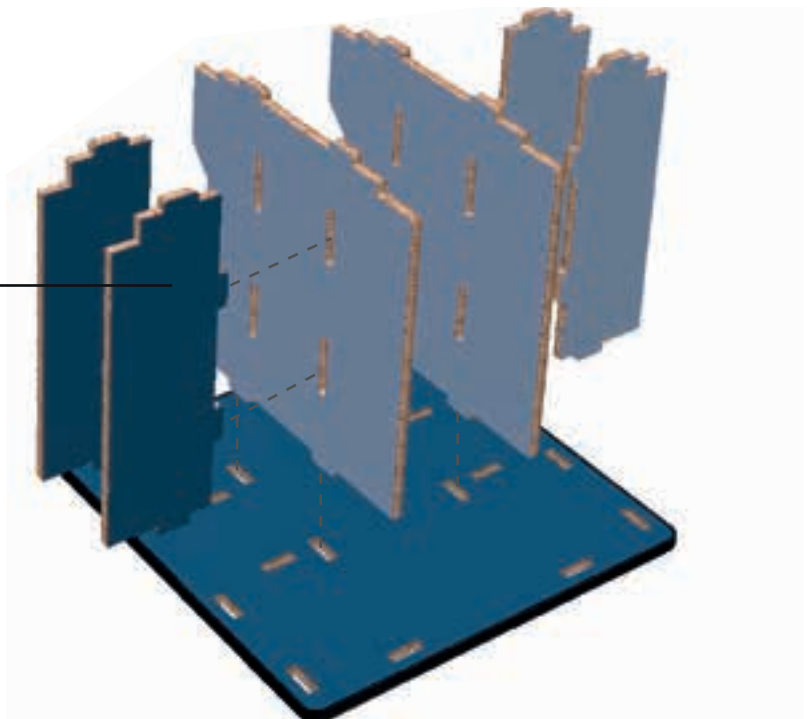
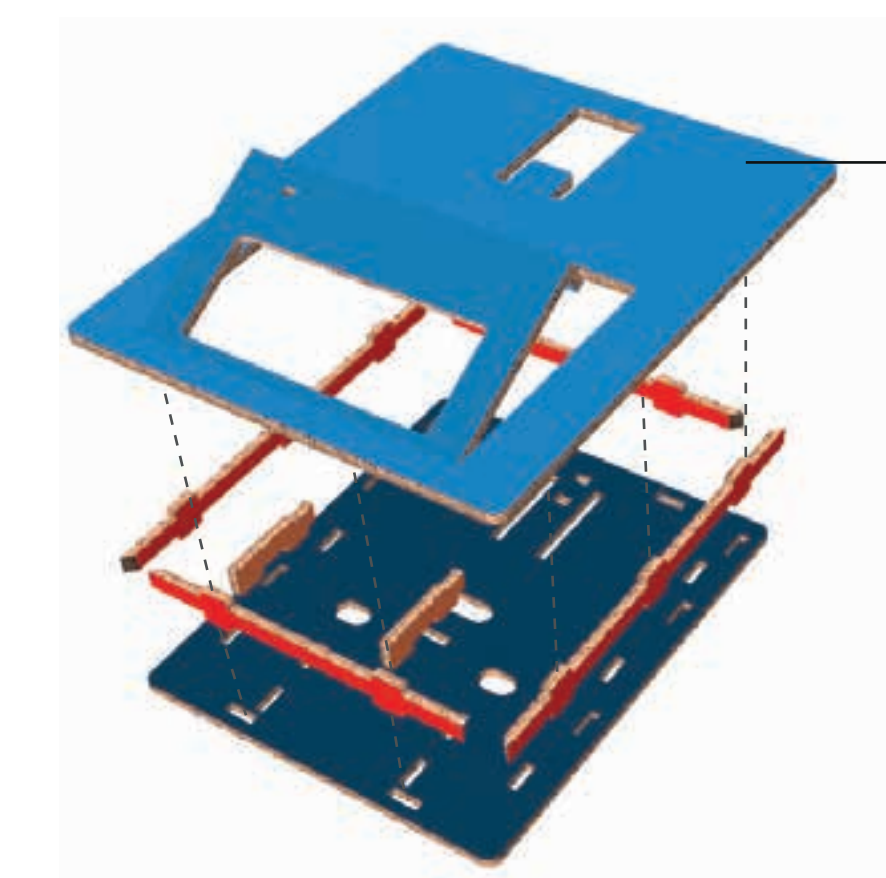
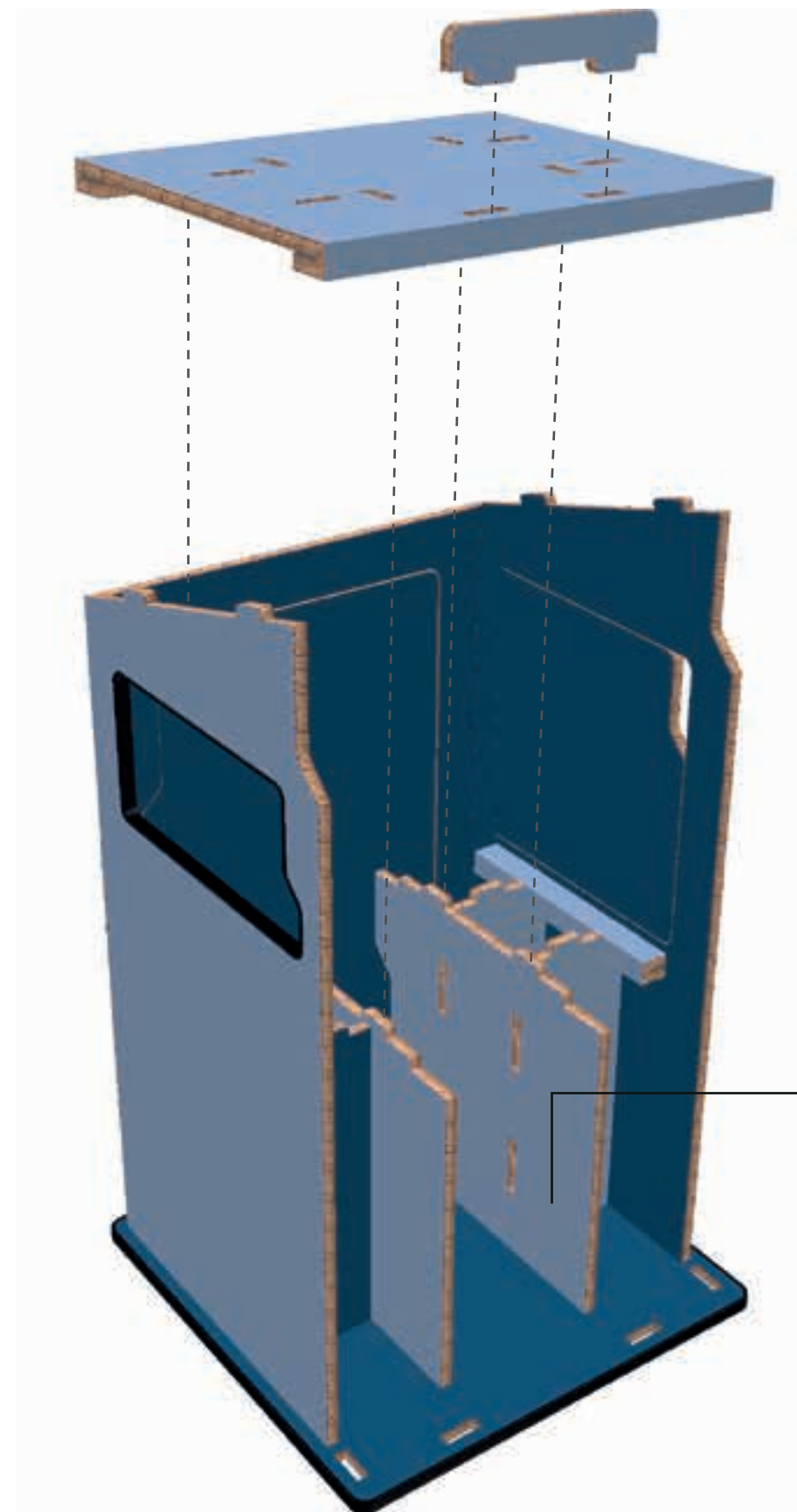

RAPHAEL FREITAS

# CONVEY

3D in Artios CAD, showing the Assembly



FURINFONS

Costumer:  
FESPA BRASIL/SP

RAPHAEL FREITAS



RAPHAEL FREITAS

# FURINFONS

**FURINFONS** is a mini-car designed for a sustainable stand called "Application Village" in Fespa Brasil Fair 2013, executed by Artwork Digital and Fujifilm. The theme of this stand is the Childhood.

SENAI FIEMG



ARTDECO TABLE

Costumer:  
SENAI/MG

RAPHAEL FREITAS

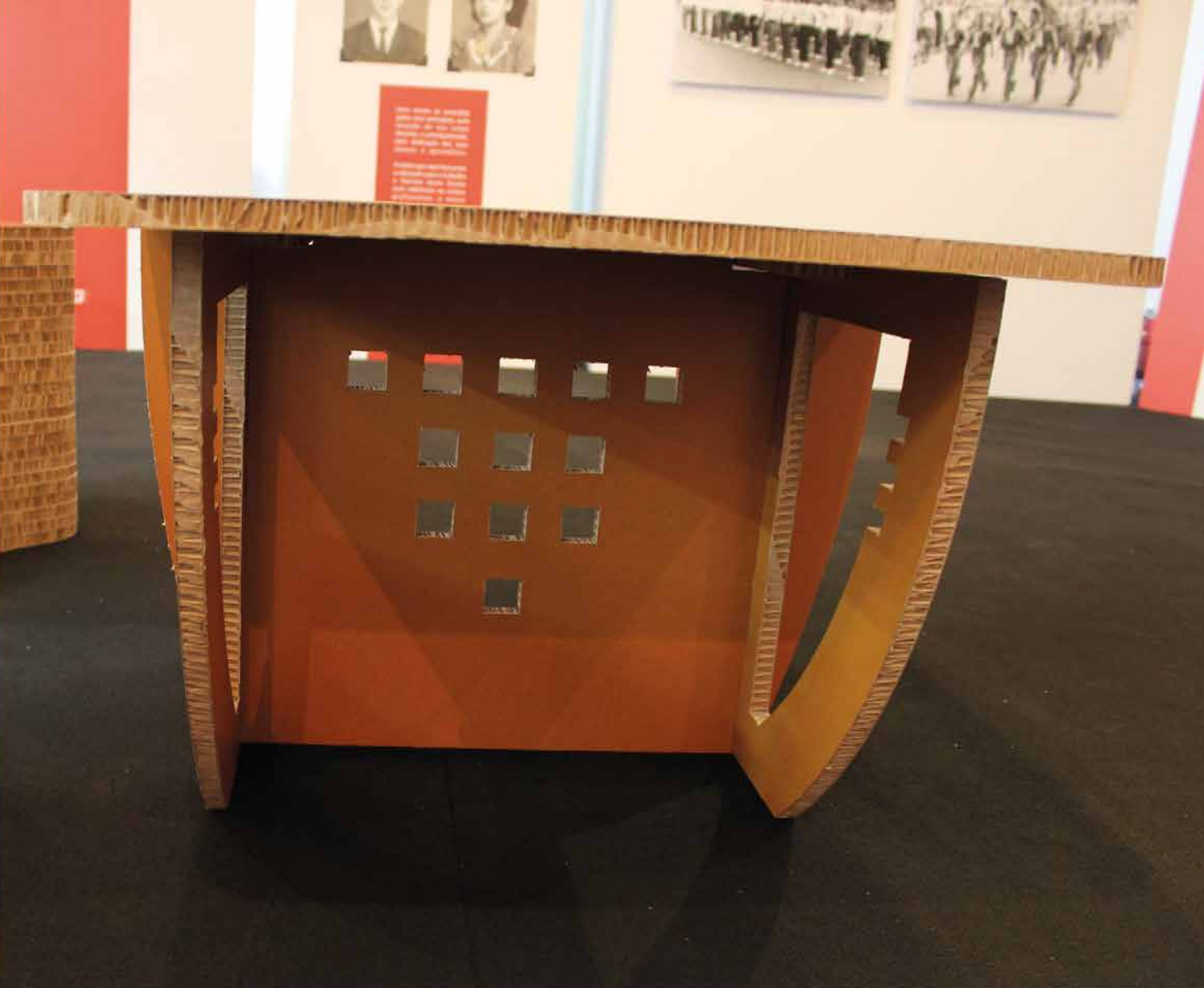

RAPHAEL FREITAS

# ARTDECO TABLE

THE ARTDECO TABLE and the seats, is some of the elements of the 70th. anniversary of SENAI Belo Horizonte. Material: Re-Board 16 mm. Artwork Digital.

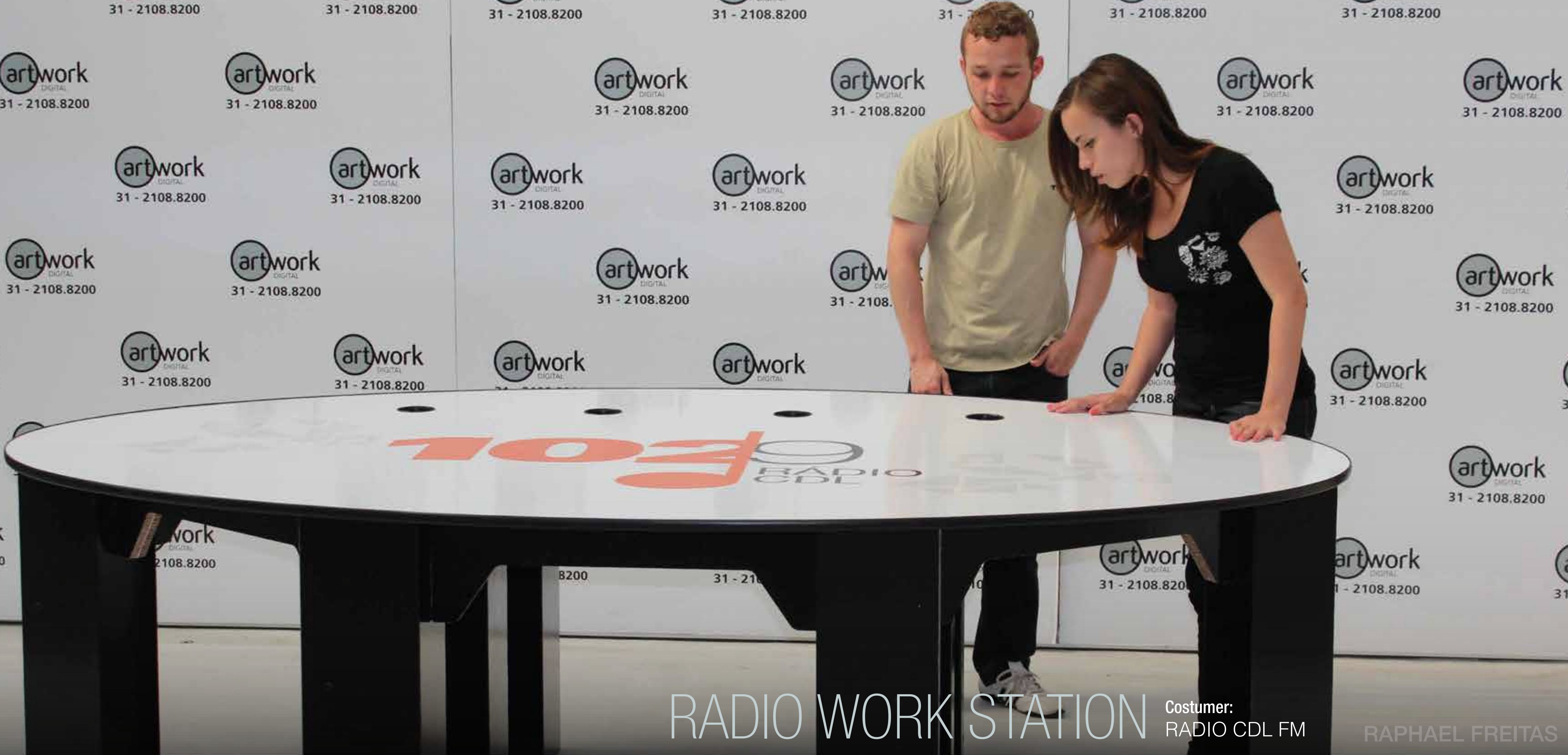

# RADIO WORK STATION

Customer:  
RADIO CDL FM

RAPHAEL FREITAS





RAPHAEL FREITAS

# RADIO WORK STATION

**RADIO WORK STATION** is a disassembled table designed to support radio equipments. It is very light and resistant, and easy to transport to other places. Material: Re-Board 16 mm. Artwork Digital

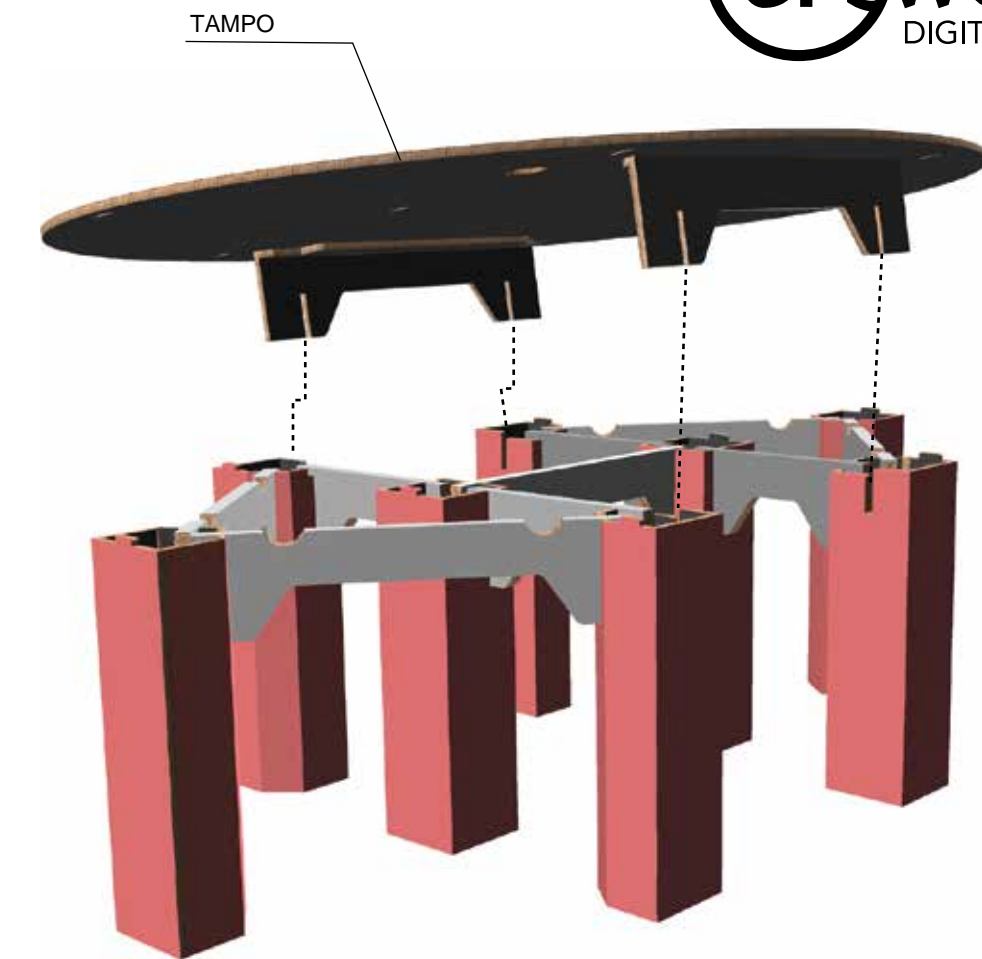
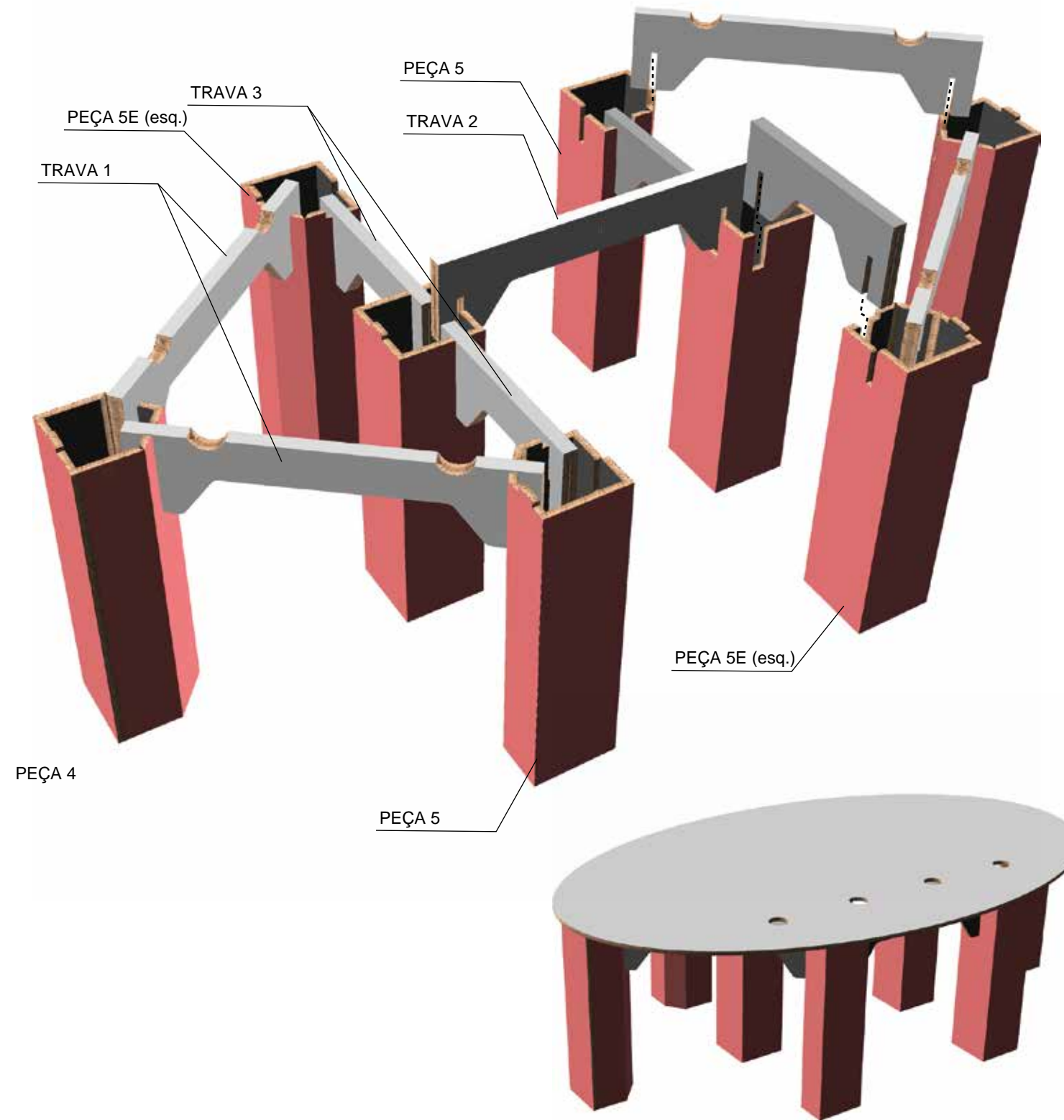
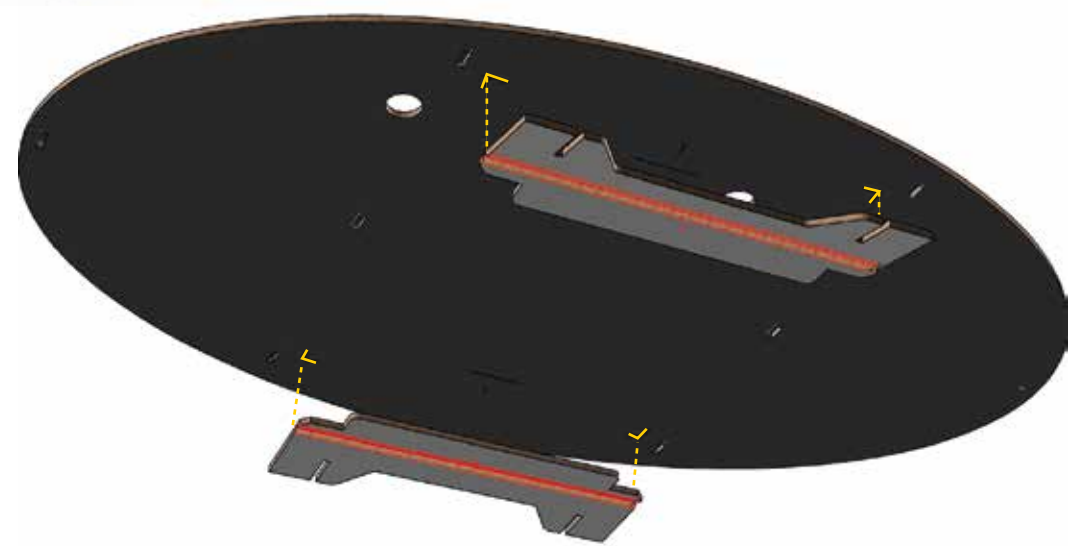
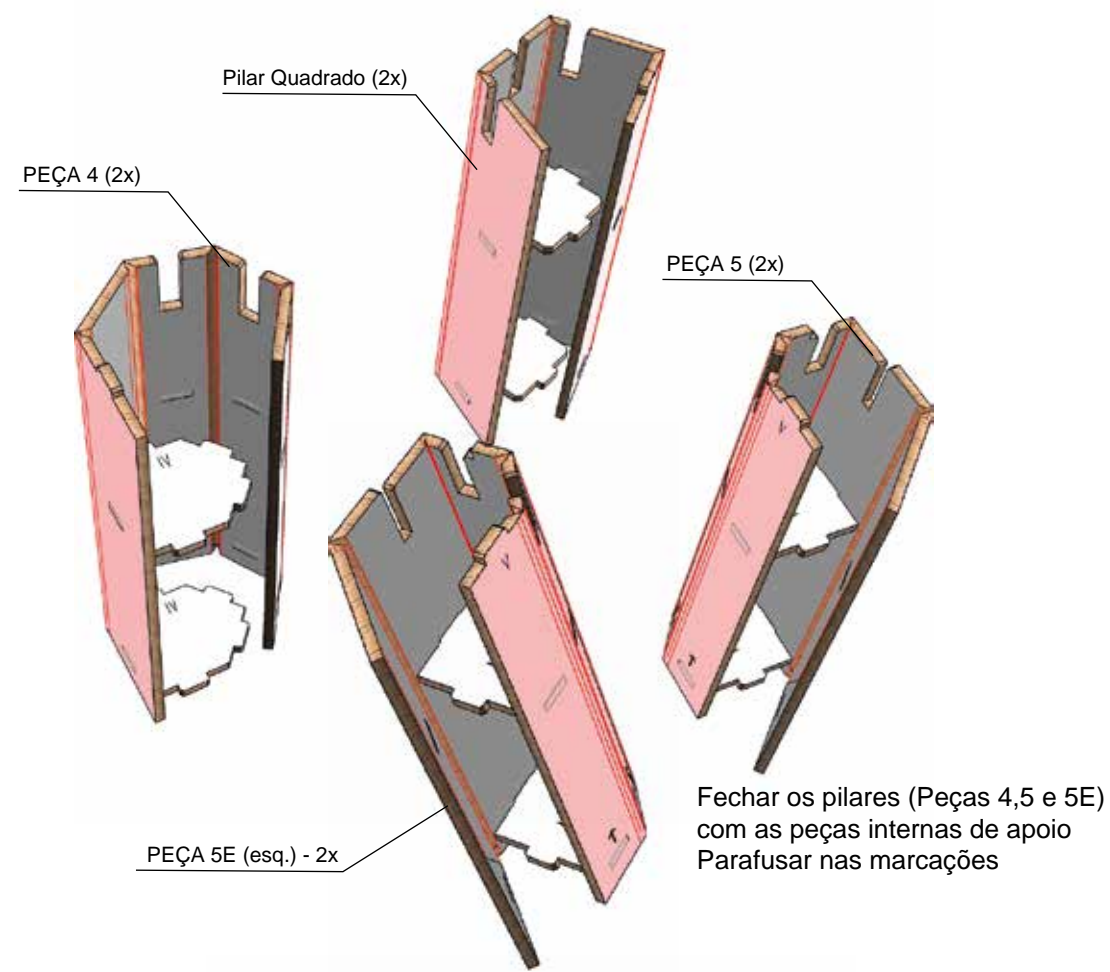

RAPHAEL FREITAS

# RADIO WORK STATION

**RADIO WORK STATION** is a disassembled table designed to support radio equipments. It is very light and resistant, and easy to transport to other places. Material: Re-Board 16 mm. Artwork Digital



Tenha uma visão clara na chuva.

PALHETAS LIMPADORAS DE PARA-BRISAS



31



28" / 70cm

**NOVO!**

MICHELIN

STEALTH

WIPER BLADE DISPLAY

Costumer:  
RADIO CDL FM

RAPHAEL FREITAS

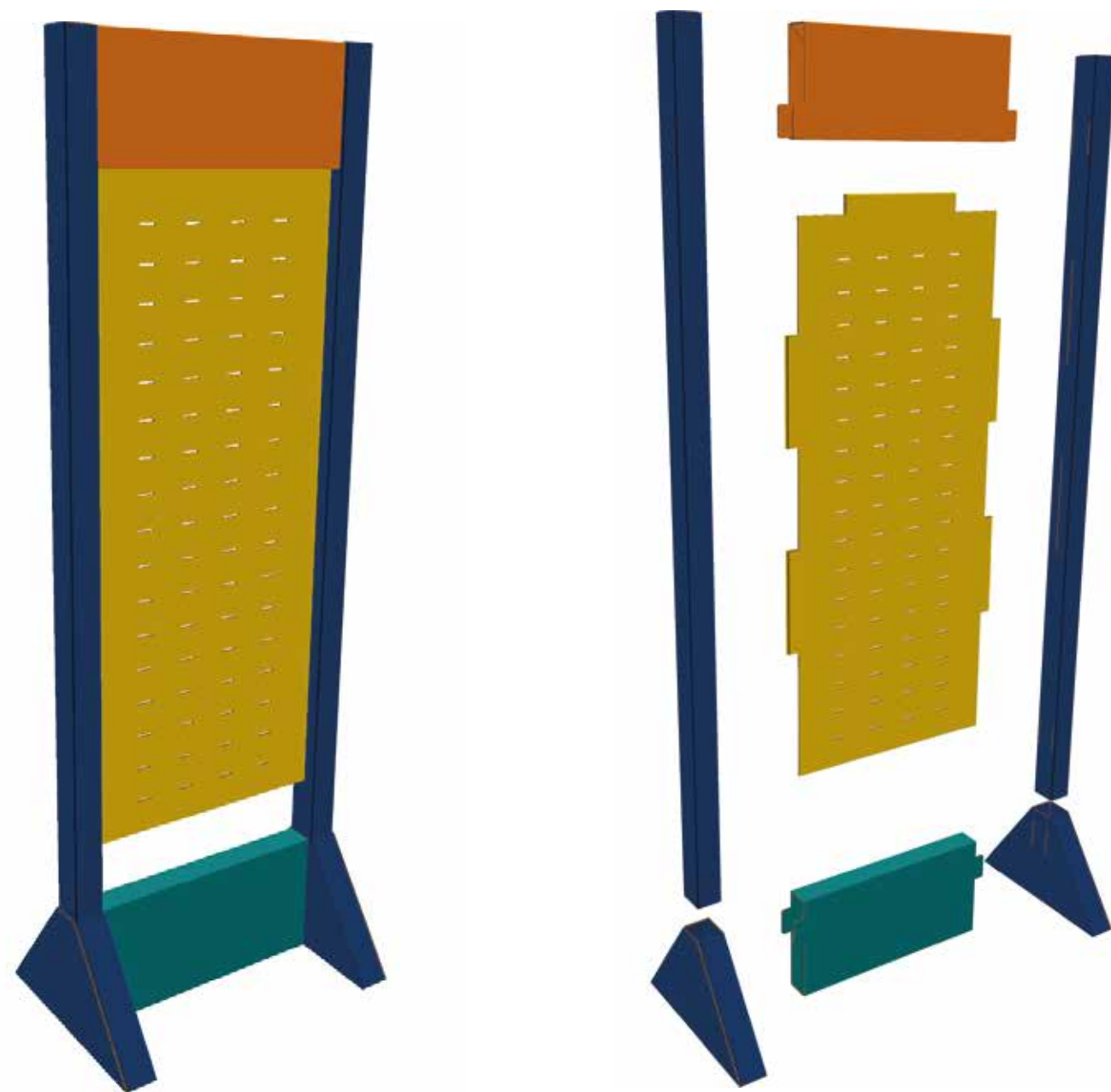
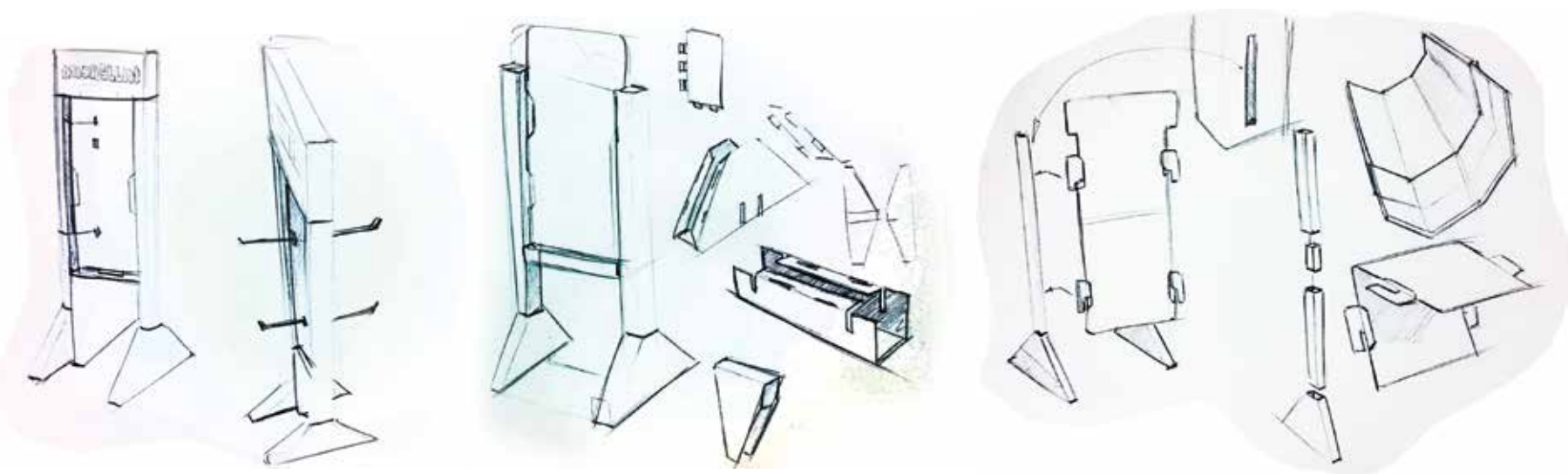

RAPHAEL FREITAS

# WIPERBLADE DISPLAY

WIPER BLADE DISPLAY is an economic expositor, designed to a large distribution to various dealers. It's very easy to transport and assembly. Material: Paper-Board. Artwork Digital.



UNILEVER GONDOLA POINT

Costumer:  
UNILEVER

RAPHAEL FREITAS

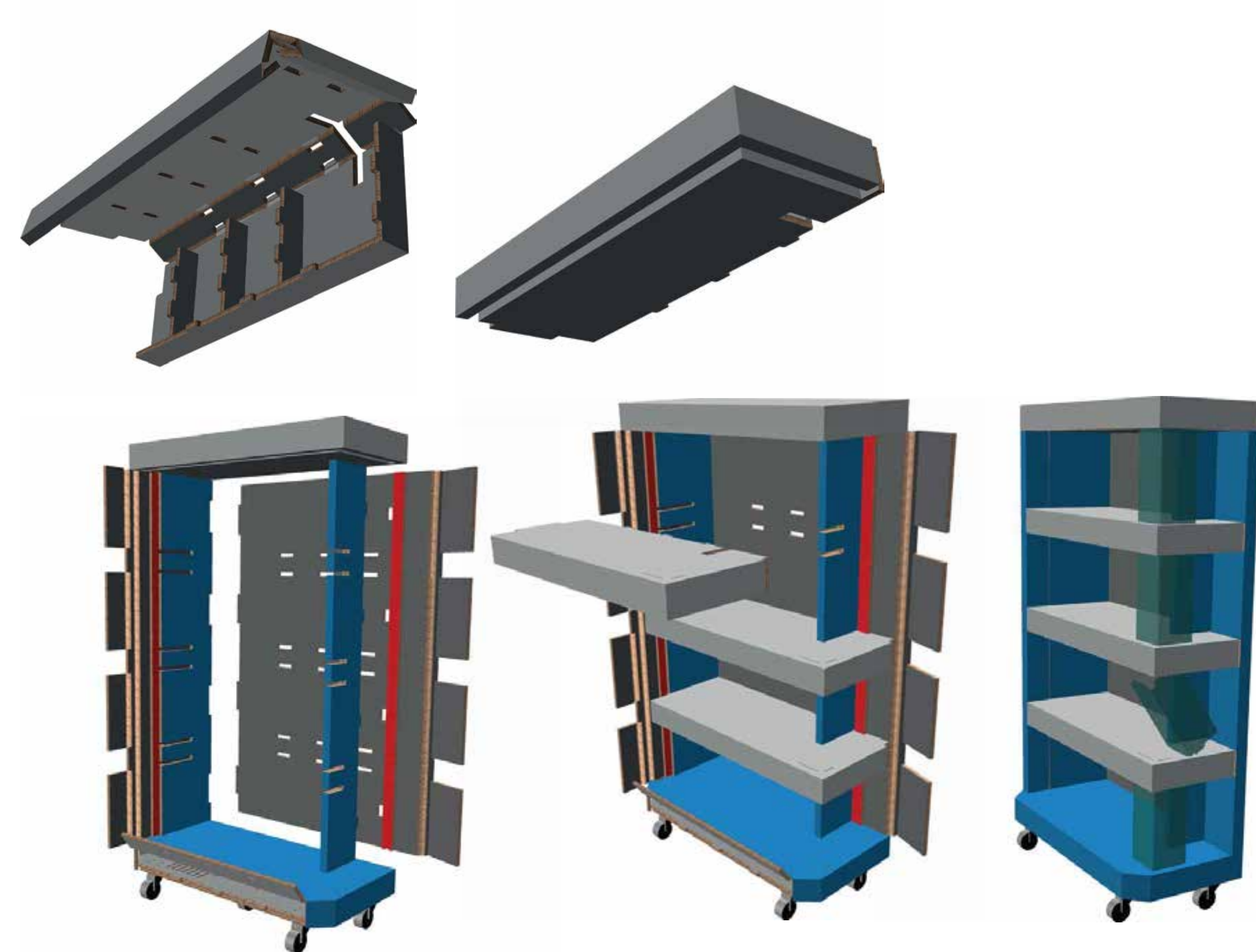

RAPHAEL FREITAS

# GONDOLA POINT

UNILEVER GONDOLA POINT is a prototype for Zona Sul Supermarket to show some Unilever products. Material: Re-Board 16mm, LED ultra light, PETG 2 mm



CONNECT



MONTANHA



CATAVENTO

SEE MORE...

[WWW.COROFLOT.COM/RAPHAELSOUZA](http://WWW.COROFLOT.COM/RAPHAELSOUZA)

# PROFESIONAL EDUCATION SKILLS

- Detail designer of steel structures  
Metalmax Projects (2007-2009)
- Internship Designer  
Hum Ponto Design (05/2012 - 07/2012)
- Internship Designer  
Artwork Digital ( 09/2012 - 12/2013)
- **PRODUCT DESIGNER**  
ARTWORK DIGITAL, SINCE 01/2014

- Mechanical Technician - Graduated  
CEFET-MG
- **PRODUCT DESIGN -**  
GRADUATED UEMG, 2013
- **INTERFACE ERGODESIGN:**  
**INFORMATION ARCHITECTURE:**  
PUC - RIO, 12/2016

- **Softwares:**  
Alias ; Solid Works; Photoshop;  
Illustrator; 3D Studio Max;  
AutoCAD; ArtiosCAD.
- **Foreign Language:**  
English
- **Skills:**  
Free-hand sketching; Photoshop  
Rendering.

31 3442-2324

31 98733-9466

RAPHAEL.FREITASOUZA@GMAIL.COM  
www.coroflot.com/raphaelsouza

RAPHAEL  
**FREITAS** CURRICULUM

**RAPHAEL FREITAS**  
Product Designer and student of  
Interface Ergodesign (Post Graduation) in PUC-Rio.