

“A camera crane for smaller productions, documentary shoots and enthusiasts.”

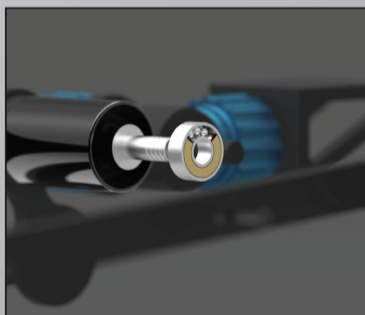

PELIKAN

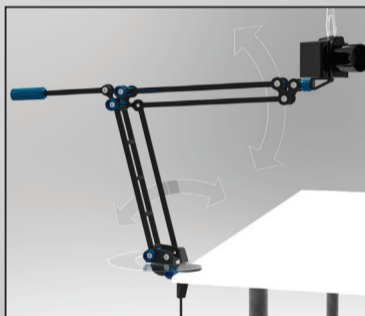

**PORTABEL**

Pelikan is designed to be portable, and easy to handle. The light weight and small size allows for easy transport from recording site to recording site.

The ability to collapse it makes it space-saving and easy to transport together with the rest of the camera equipment.

The solid construction is important with regard to transportation. The device is thus not dependent on any form of special care during handling. This supports the feeling of quality and robustness.



**PLACEMENT AND MOUNTING**

When the camera is mounted on the crane, it is only necessary with one action to place the Pelikan - and is thus ready for use.

The Pelikan is mounted with a one-hand quick clamp along with the standard camera plate on a 70 mm ball head. The quick clamp makes Pelikan flexible as it can be attached to many different objects and shapes.

It is also suited to be attached to standard tripods and other standard camera equipment.



**EASY TO USE**

It's important that the Pelikan feels easy to use, and easily produces good results. The precisely molded parts should be without any play, and give a feeling of good quality and controll.

The various ways of moving and handling Pelikan give the user alot of flexibility and room to experiment in the choice of pictures and movements.

In combination with the possibility of mounting the camera horizontally or vertically on the cameraplate, results in few limitations in the recording situation.