

Esc: 2.5:1

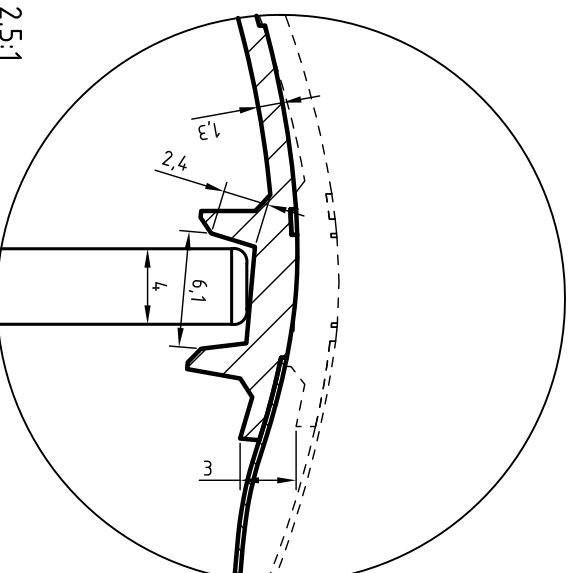

Esc: 2.5:1

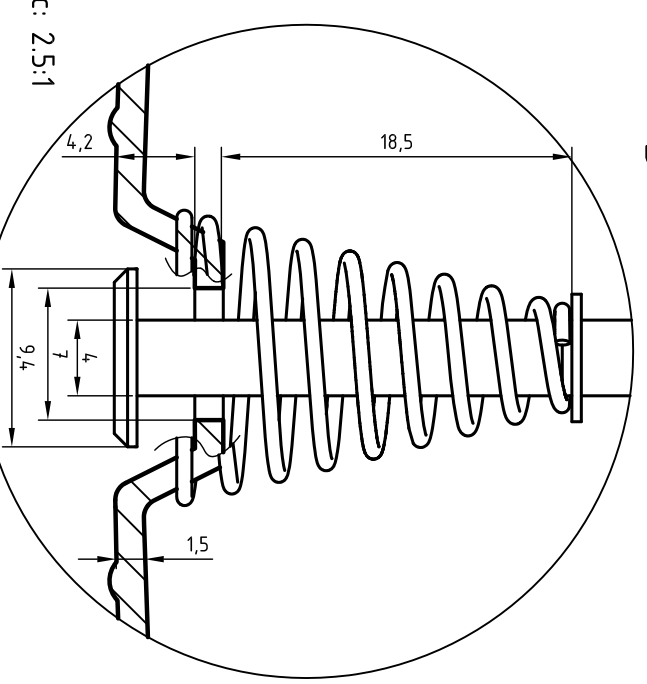

Detalle A

Detalle B

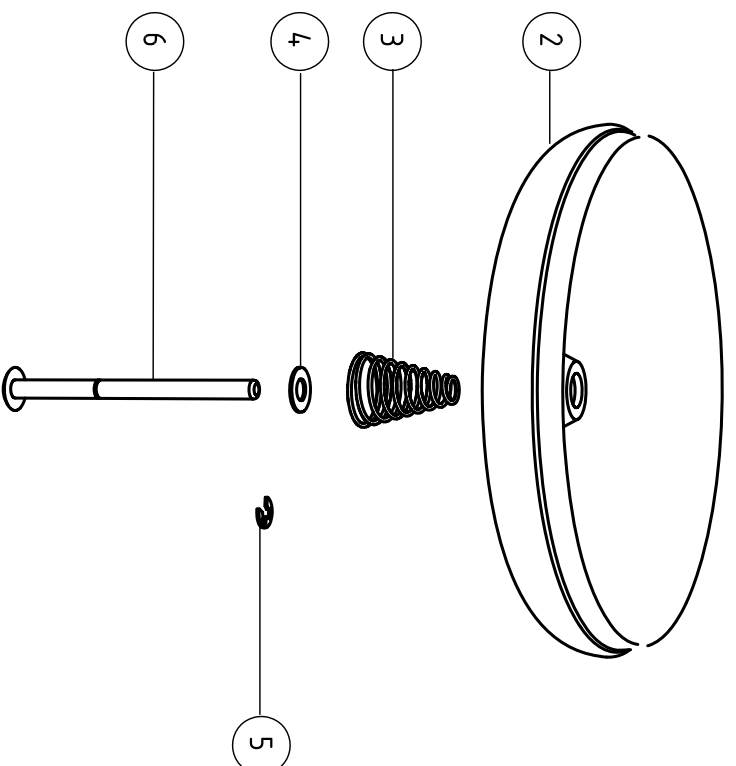

5	Eje de accionamiento	HDPE	1		
5	aro Seeger	Acero	1		
4	Arandela	Caucho	1		
3	Resorte	Acero Inoxidable	1		
2	carcasa inferior	HDPE	1		
1	Carcasa superior	HDPE	1		
Nº	Denominacion	MATERIAL	CANTIDAD	PESO (g)	Oversecciones

Dib.	Fecha	Nombre	Diseño 3	DISEÑO INDUSTRIAL FADU / UBA 2012
Rev.				
Apr.				
Esc.				

Esc.	1:1	Alumnos
Tolerancia:		

Envase quitamanchas CIF		Alumnos
Peso		

Nº de pieza		Martin Esteva
-------------	--	---------------