

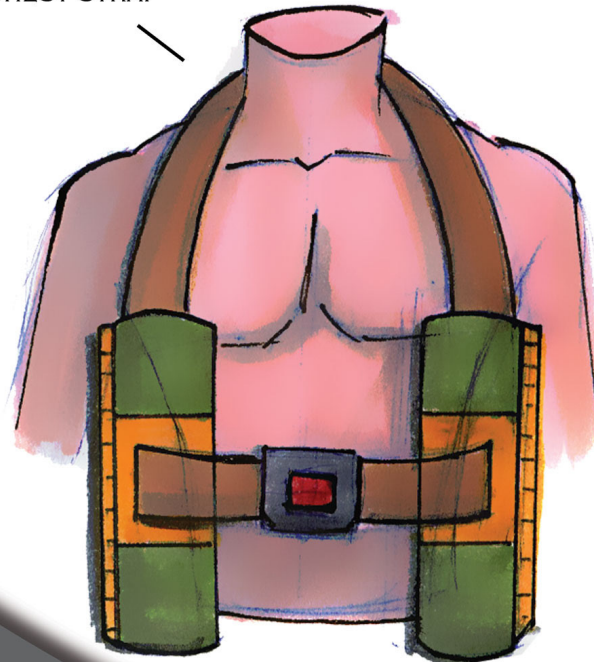

# LIBRA

BAGS REST AGAINST RIBS,  
SECURED BY A NECK,  
BACK AND CHEST STRAP



STORAGE COMPARTMENT CAN  
BE ACCESSED BY A SLIDING DOOR

INTERIOR COMPARTMENT IS  
INTERCHANGEABLE

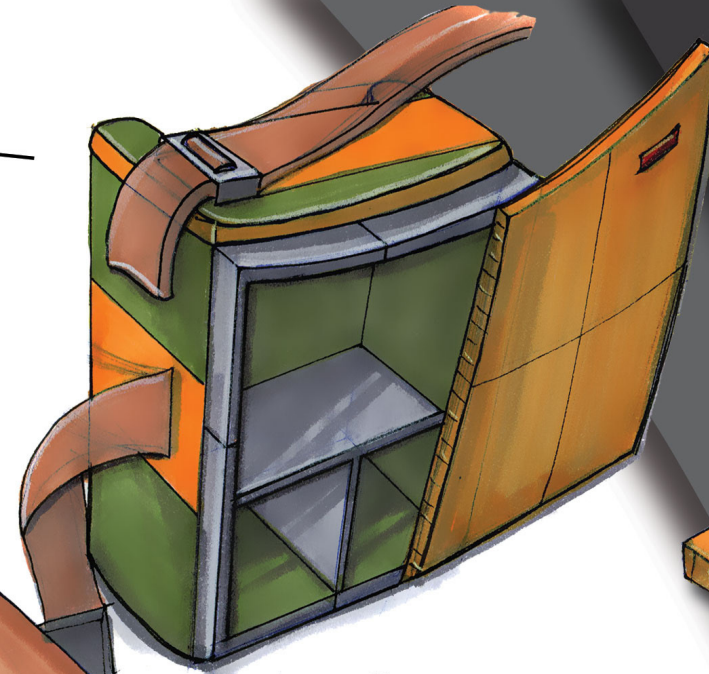

INNER RECESS DESIGNED  
TO REST ERGONOMICALLY  
AGAINST THE RIBS,  
PREVENTING SWAY AND  
CHAFFING

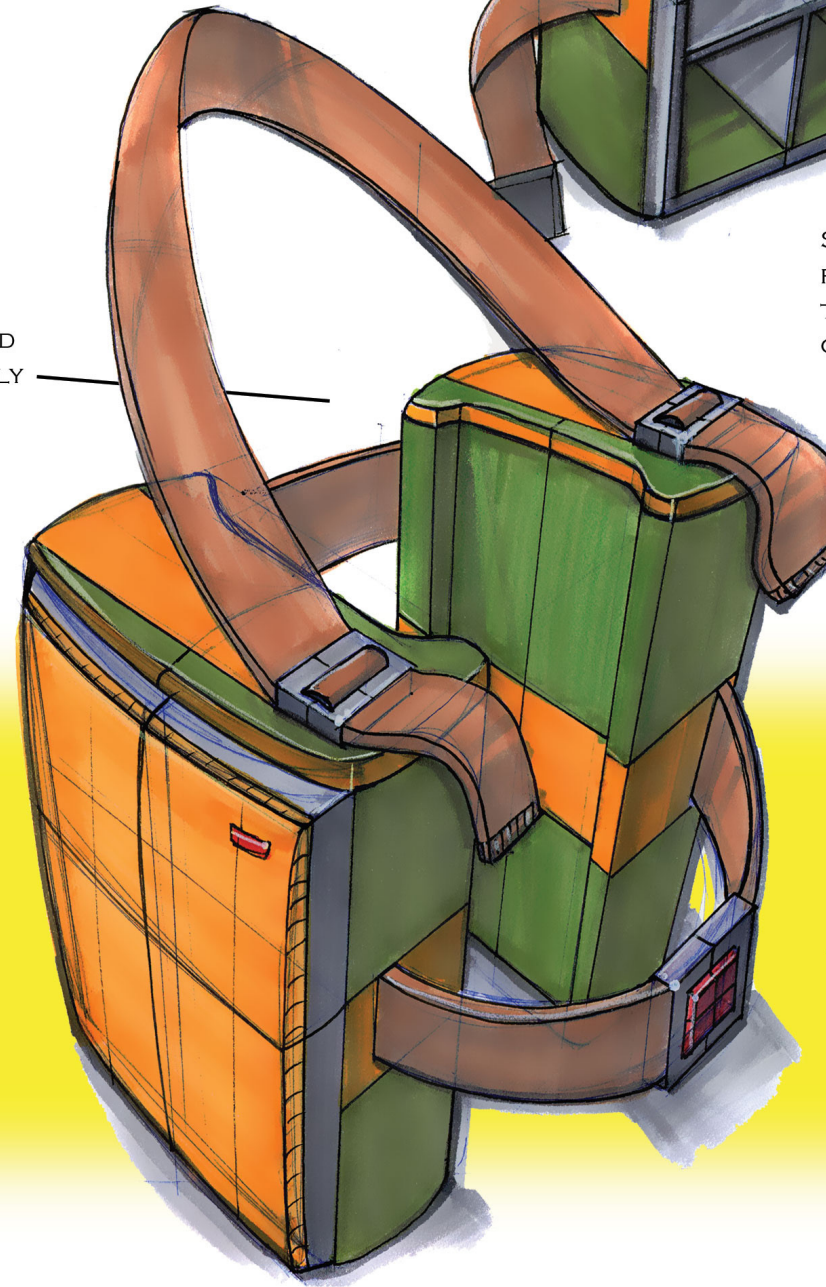

SLIDING DOOR CAN BE  
REMOVE FROM THE BAG  
TO BE USED AS A HEAD REST  
OR CUSHION

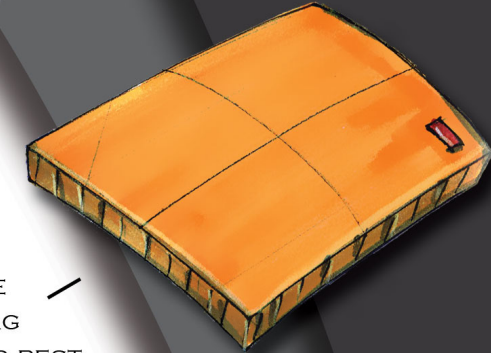

ADJUSTABLE CHEST  
AND BACK STRAPS

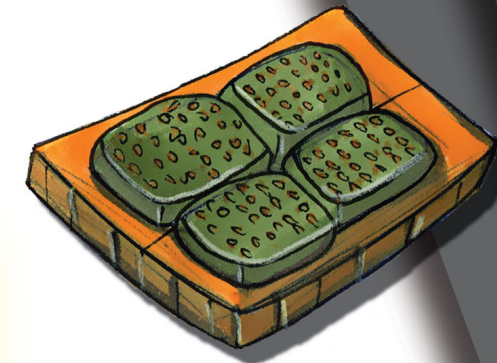

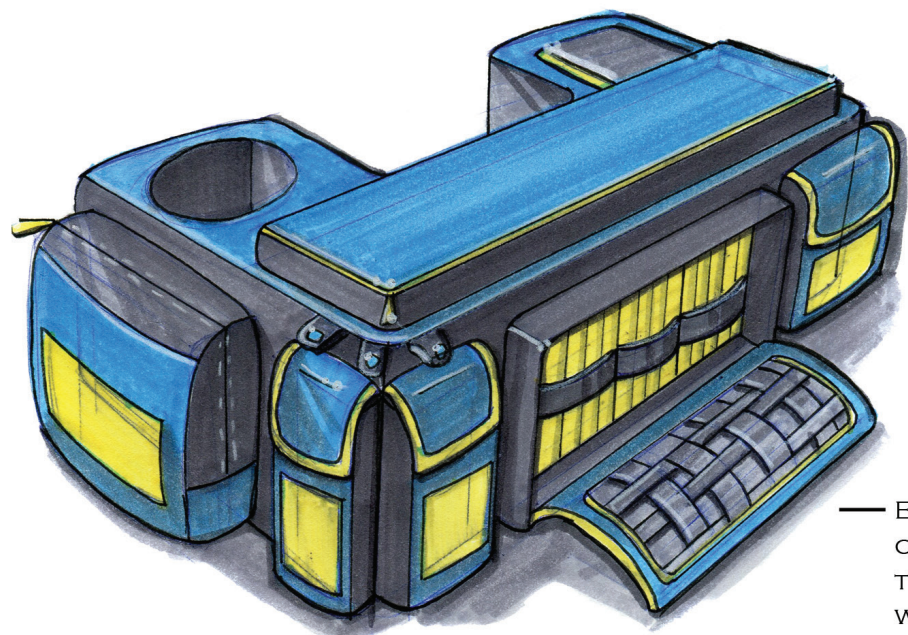

— THE BAG IS SYMMETRICAL ON EACH SIDES FOR BOTH LEFT AND RIGHT USERS.

— ELASTIC BAND WEBBING CONFORMS TO THE SHAPE OF TOOLS AND EQUIPMENT BY WEAVING THE TOOL OR OBEJECT IN BETWEEN NEIGHBORING BANDS.

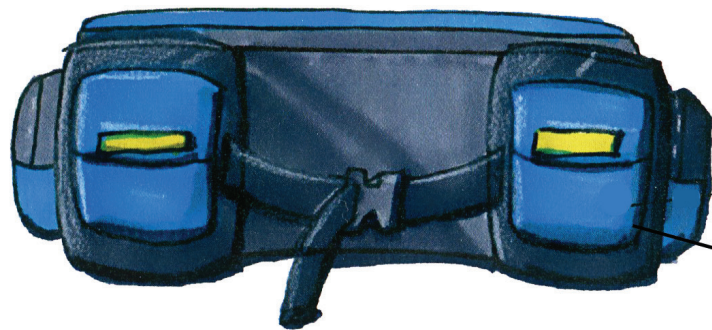

FRONT POCKETS CAN BE USED AS STORAGE OR A GLOVE DISPENSORY UNIT.

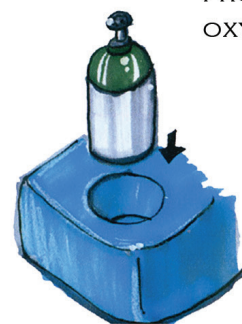

MINI OXYGEN POCKET PROVIDING INSTANT OXYGEN USAGE

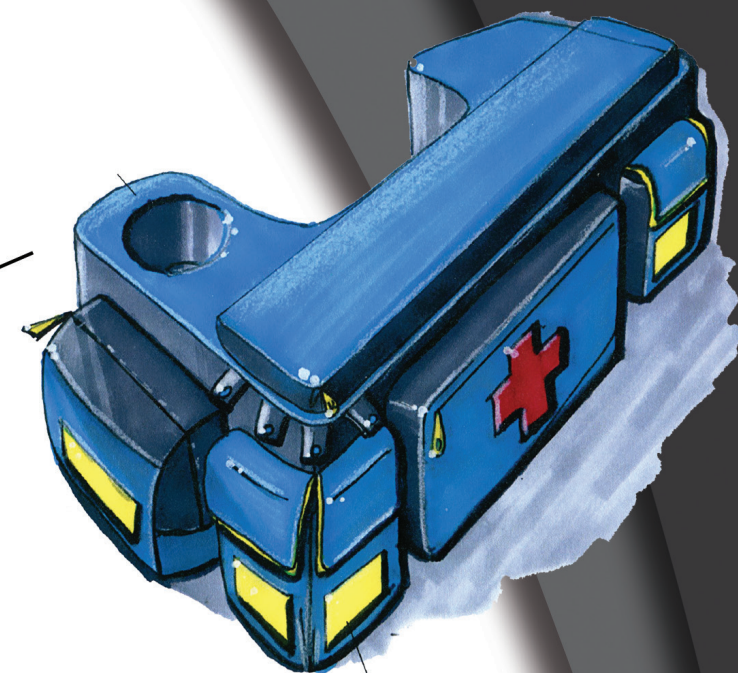

THE BAGS MAIN COMPARTMENT IS ACCESSED USING DUAL QUICK ZIPPERS TIES, LIMITING THE AMOUNT OF TIME NEEDED TO REACH SUPPLIES. THE ENTIRE COMPARTMENT IS ADJUSTABLE AND MODULAR.

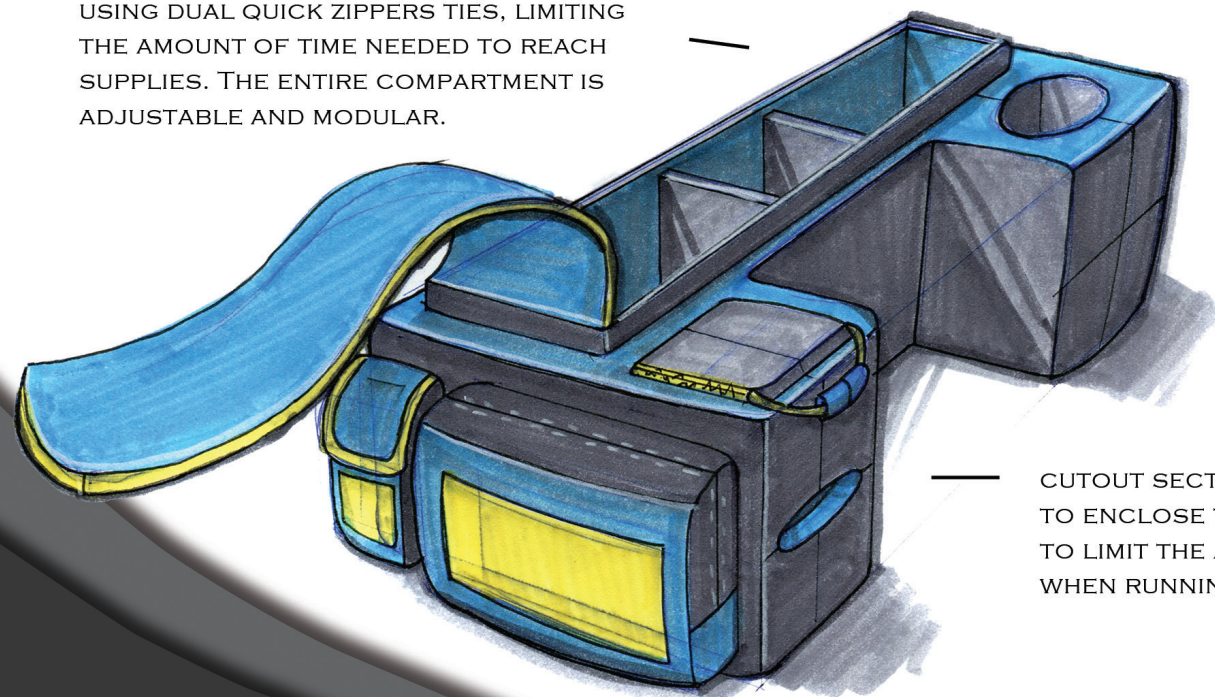

BAG IS SECURED AROUND THE HIP OR THIGHT WITH AN ADJUSTABLE STRAP UTILIZING MEMORY FOAM TO PRIVED ERGONOMIC CONFORT.

— CUTOUT SECTION DESIGNED TO ENCLOSE THE THIGH OR HIP TO LIMIT THE AMOUNT OF BAG SWAY WHEN RUNNING OR WALKING.

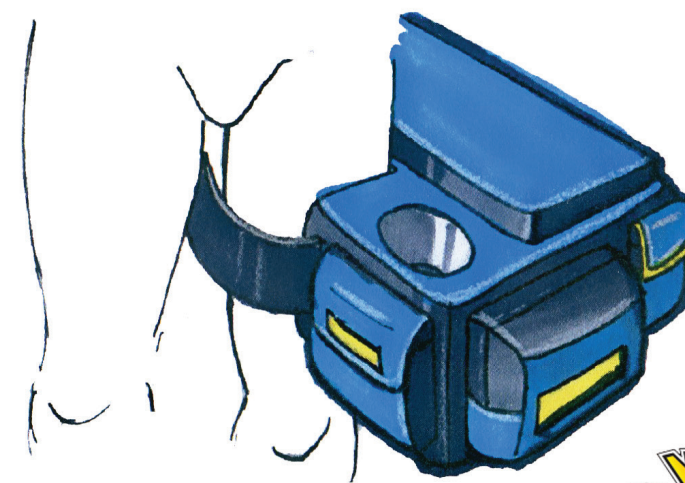

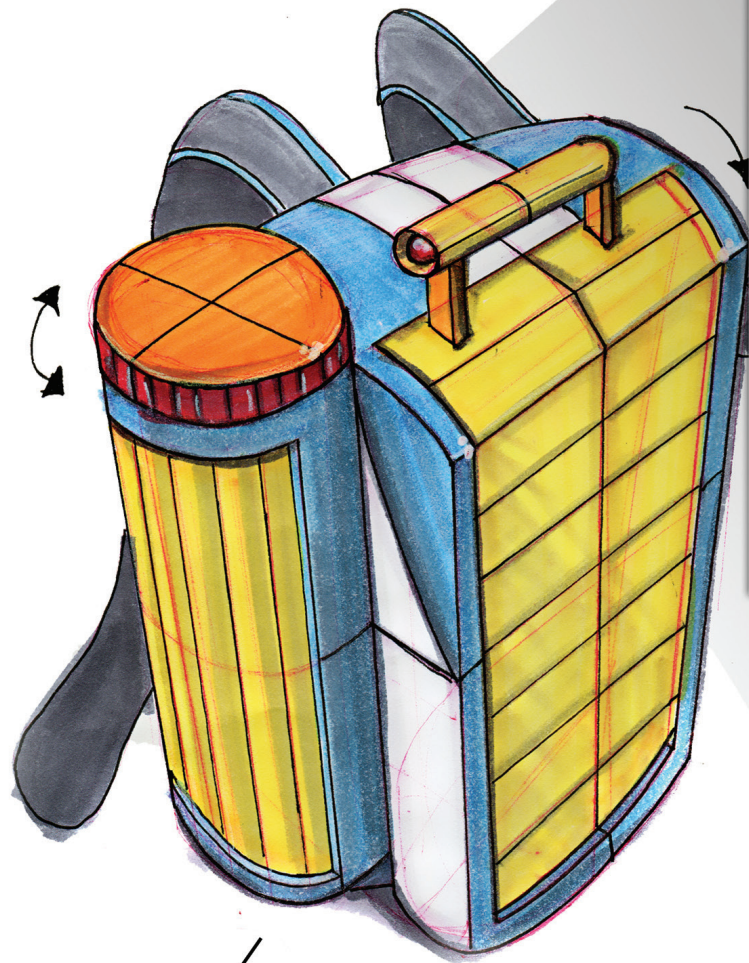

OXYGEN TANK IS REVEALED THROUGH A TWISTING COMPARTMENT. THE ROTATING COMPARTMENT GRANTS FASTER ACCESS TO OXYGEN.



SLIDING DOOR MECHANISM THAT PROVIDES THE USER WITH MORE EFFICIENT ACCESS TO TOOLS AND EQUIPMENT.

THE INTERIOR OF THE BAG CONTAINS MODULAR STORAGE, ALLOWING USERS TO CUSTOMIZE COMPARTMENTS ACCORDING TO PREFERENCE.

ERGONOMIC BACK SUPPORT PROVIDES COMFORT TO THE USER WHEN CARRYING HEAVY SUPPLIES. PADDING CONSISTS OF POLYURETHANE VISCO-ELASTIC MEMORY VFOAM.

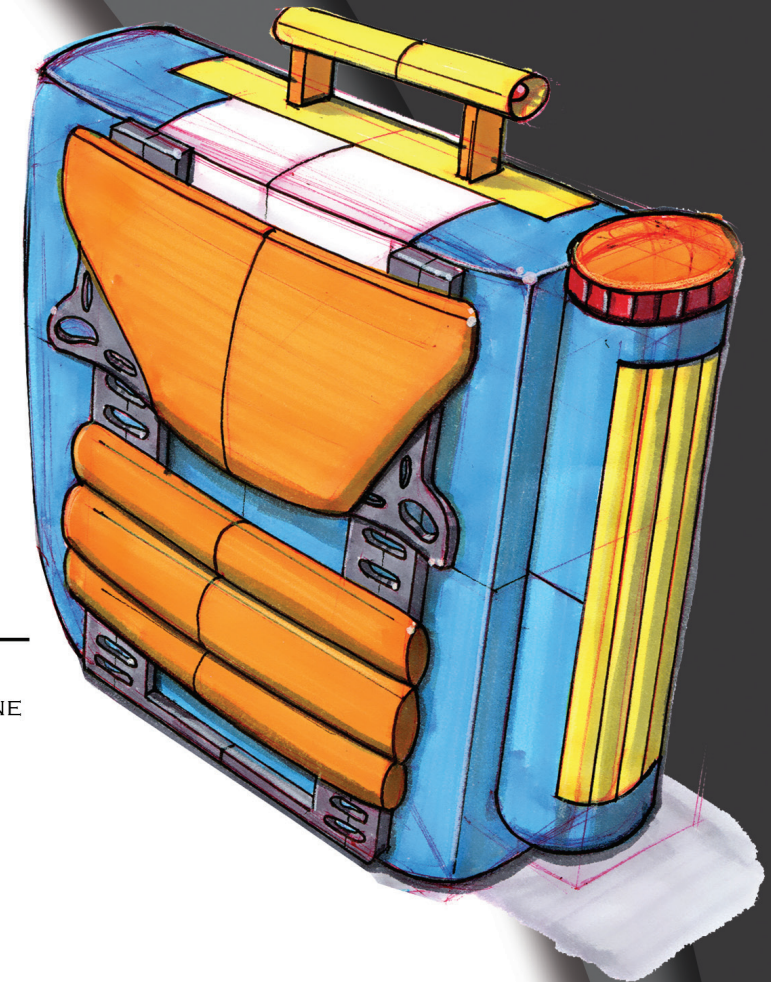

SIDE POCKETS THAT FEATURE: AN INSULATED IV POUCH, THAT GRANTS IMMEDIATE ACCESS TO VARIOUS IV BAGS.

A POCKET DESIGNED TO HOUSE A SHARPS CONTAINER AND OTHER VARIOUS TOOLS.

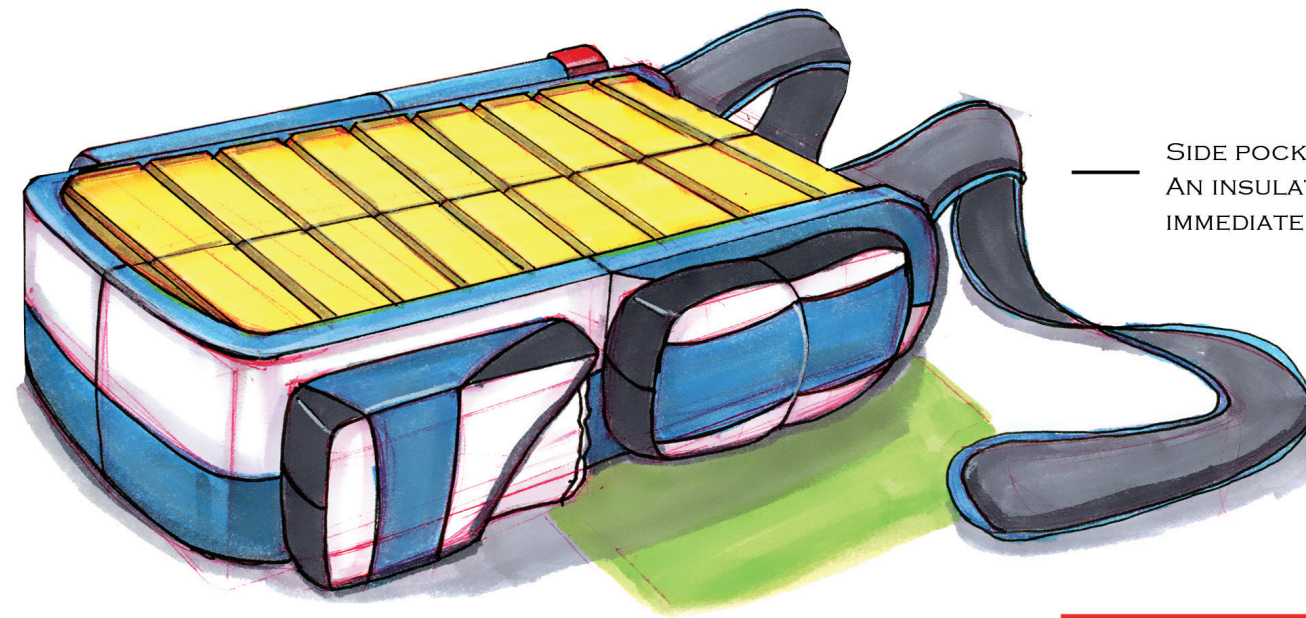

# DRABATATIS

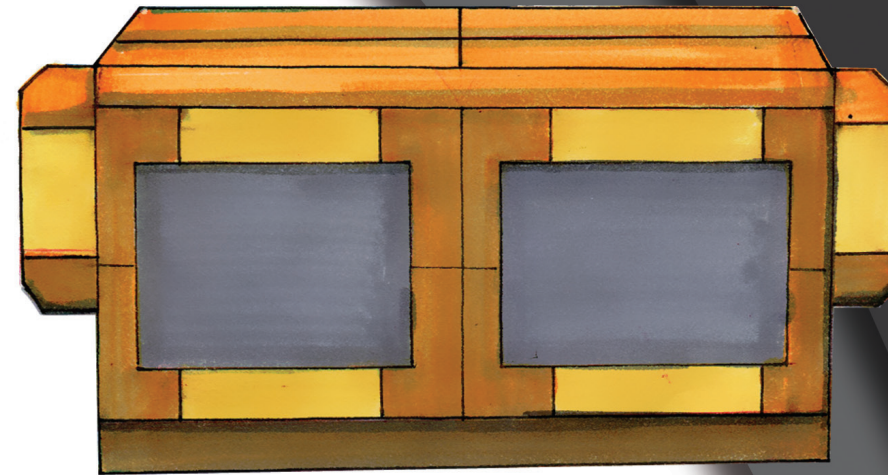

TOP SLIDING DOORS HAVE A RECESS DESIGNED TO BE USED AS A TRAY FOR TOOLS, BAGS, AND LOOSE ITEMS

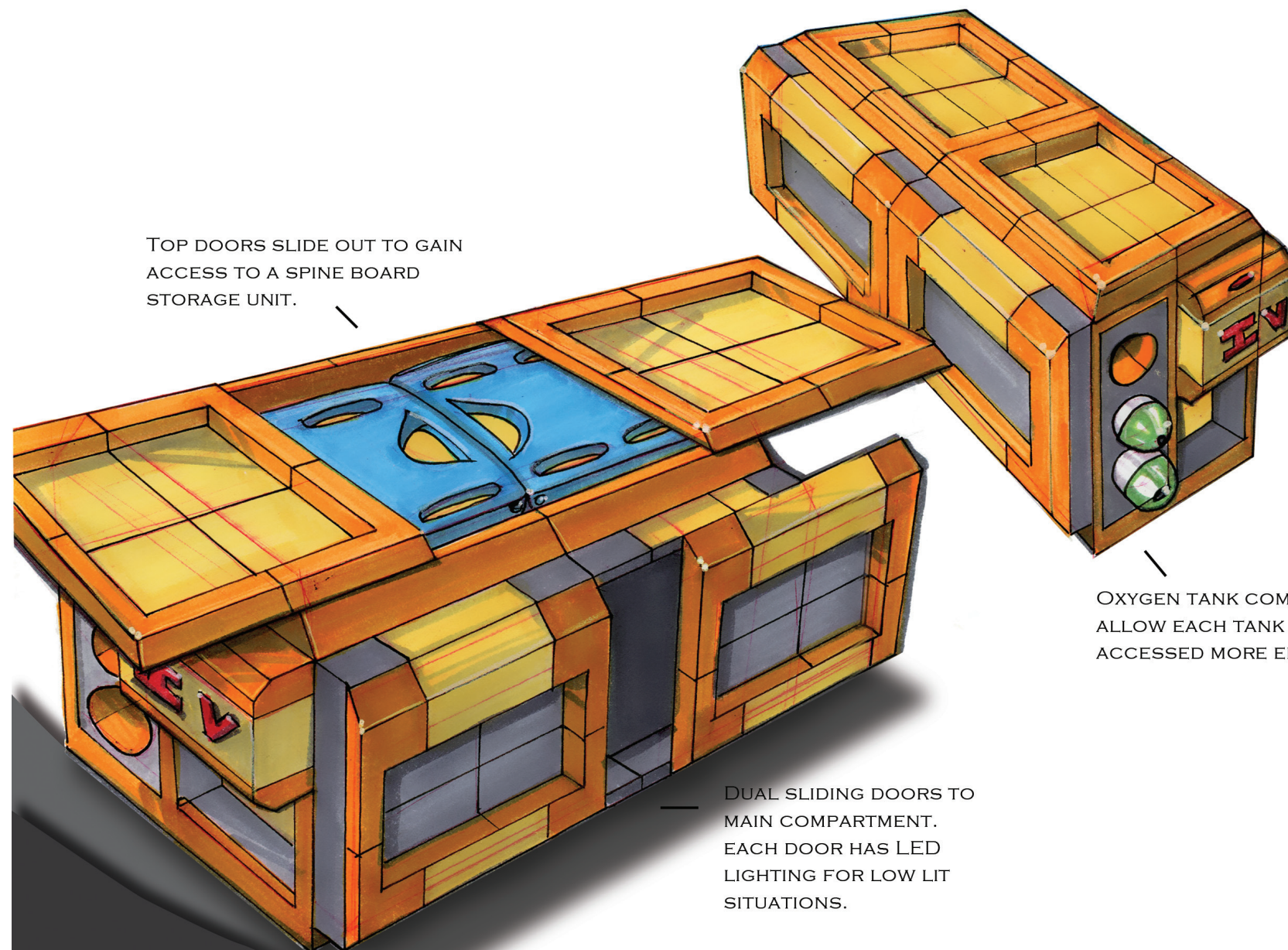

TOP DOORS SLIDE OUT TO GAIN ACCESS TO A SPINE BOARD STORAGE UNIT.

OXYGEN TANK COMPARTMENTS ALLOW EACH TANK TO BE ACCESSED MORE EFFICIENTLY.

DUAL SLIDING DOORS TO MAIN COMPARTMENT. EACH DOOR HAS LED LIGHTING FOR LOW LIT SITUATIONS.

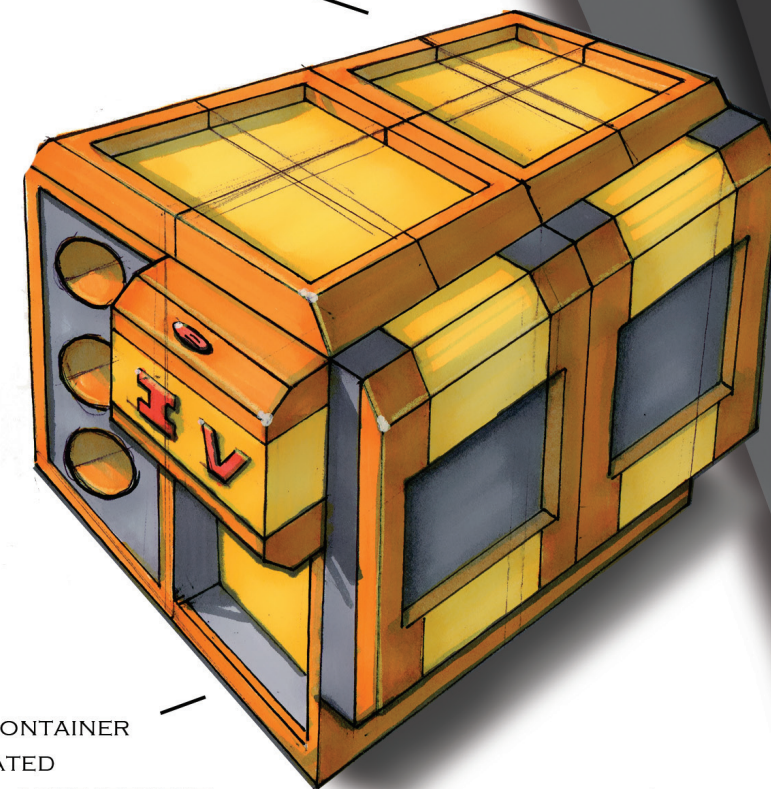

INSULATED IV CONTAINER AND A DESIGNATED DEFIBRILLATOR COMPARTMENT.