

VAL-MATIC®

Preferred Features

Advanced Technology

Proven Design



**AWWA
Rubber Seated
Butterfly Valve**

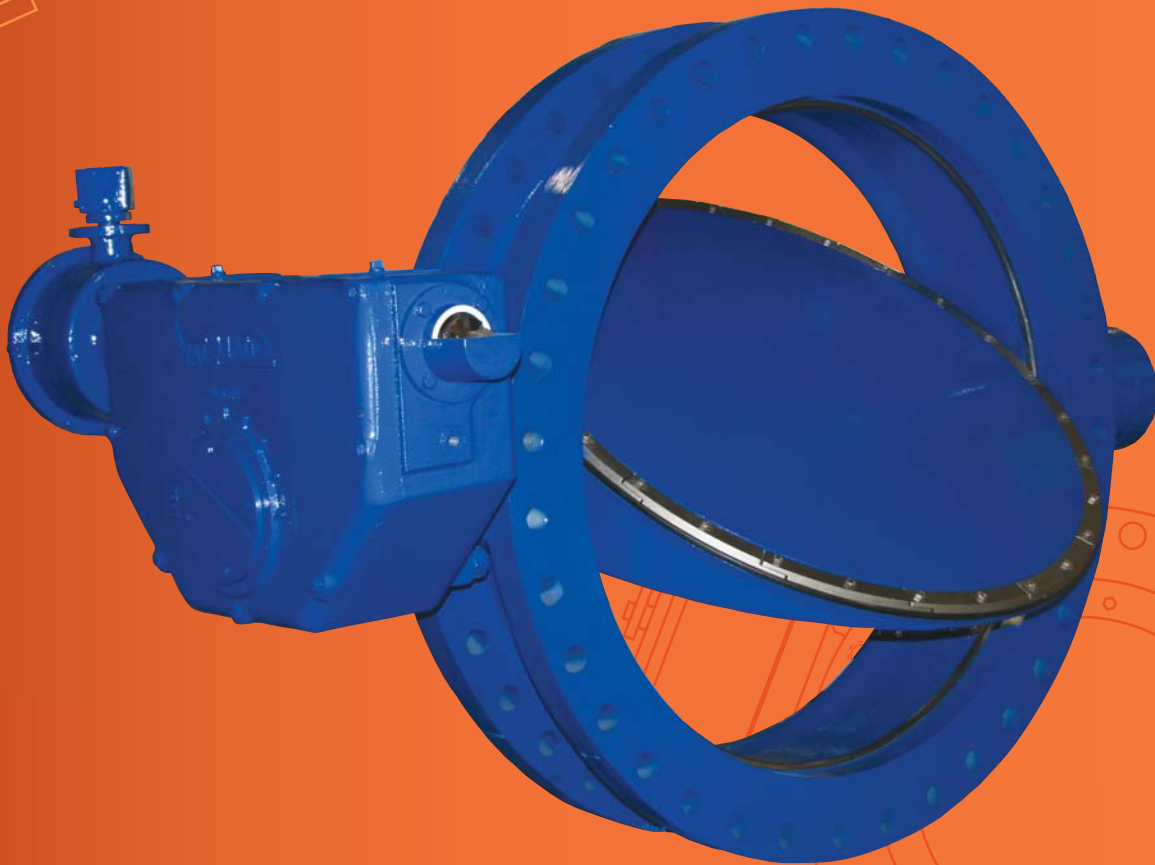

www.valmatic.com

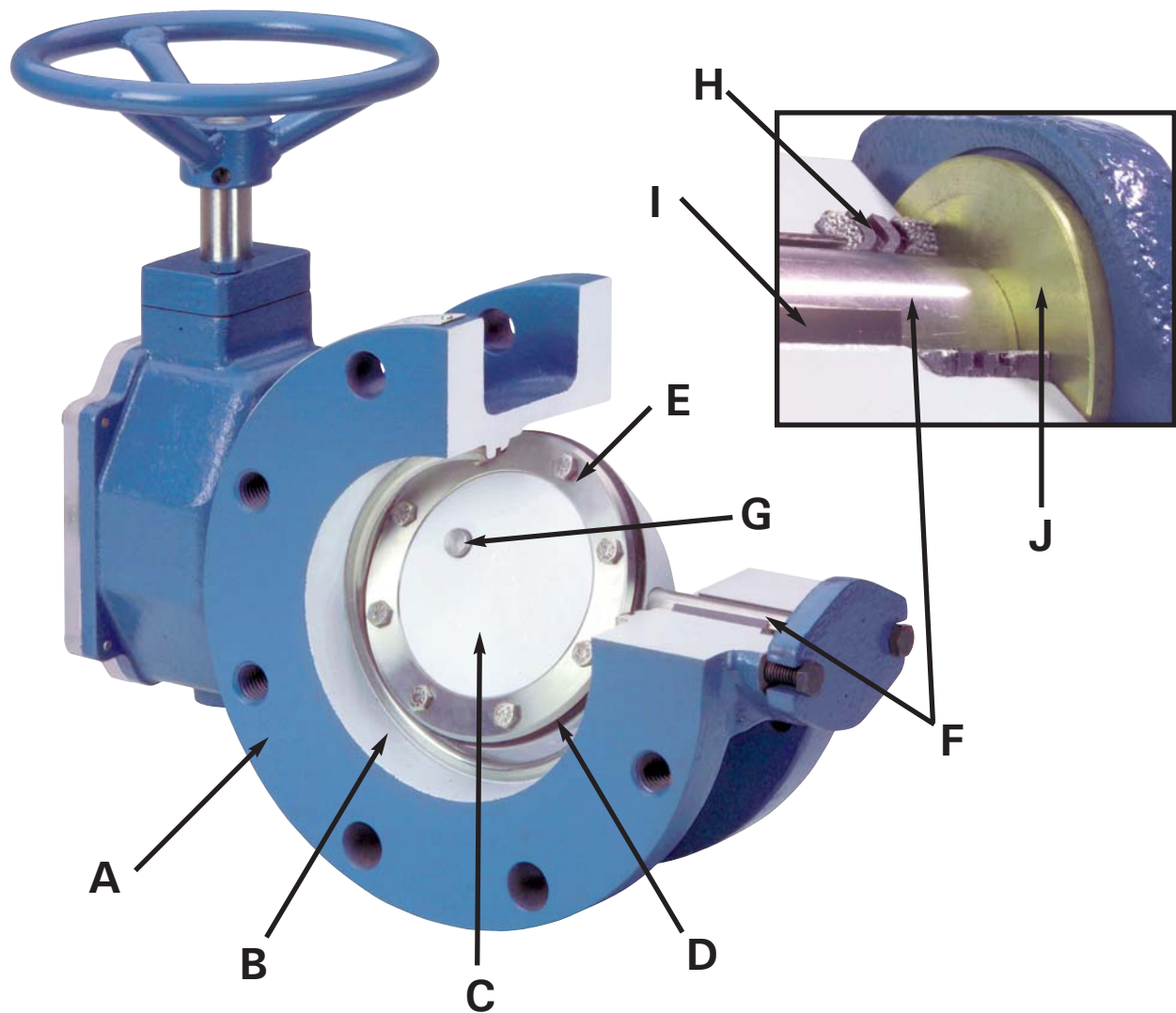

A. Body

Available in ANSI Wafer, Flanged, Mechanical Joint and Flange x Mechanical Joint End Connections in AWWA Classes 150B and 250B.

B. Body Seat

360° uninterrupted body seat with no shaft penetration facilitates leak free performance. Type 316 Stainless Steel provides long life and corrosion free mating surface for resilient seat.

C. Ductile Iron Disc

Ductile Iron provides strength and rigidity to withstand impacts from flow and pressure transients. The added strength allows the disc design to have a smaller cross section providing improved headloss characteristics.

D. Resilient Seat

Special formulated elastomers for chemical resistance and long cycle life. The 360° resilient seat is uninterrupted for positive seating.

E. Tri-Loc™ Seat Retention System

With over 35 years of proven dependability the Tri-Loc™ Seating System is easily adjusted and field replaceable. All seat hardware is Type 316 Stainless Steel.

F. Shaft

Stainless Steel shafts meet AWWA C504 diameter requirements. Through shafts provided standard on sizes 3"-24" and available on 30"-72" when specified.

G. Tangential Taper Pins

Stainless Steel Taper Pins with lock nut and o-ring seal utilizes tangential forces of the taper pin and lock nut to provide the most secure method available of locking the disc to shaft.

H. Shaft Seal

Shaft seal is a self-adjusting/wear compensating V-Type packing. Packing is easily replaced without removal of the valve from the line.

I. Sleeve Bearings

Low friction bearings are self-lubricating and non-corrosive, for a long, trouble-free life.

J. Thrust Bearing

Factory set bronze thrust bearing assures proper centering of valve disc. Field adjustable in sizes 30" and larger

A PROVEN DESIGN...

With features and benefits engineers and users prefer, and manufactured with advanced technology, the American-BFV® Butterfly Valve offers today's water/wastewater professionals a superior valve at an affordable price.

PROVEN DESIGN

The American-BFV® is designed, manufactured, and tested to meet all AWWA C504 requirements. Performance tests, leakage tests, and hydrostatic testing are all performed as standard. Third party Proof of Design Testing was successfully completed and flow testing was performed at the Utah State Hydraulics Lab, one of the premier testing labs in the world.

In order to take proven design from concept to reality, it must leave the lab and travel out into the field. Only there, and only after years of operation in thousands of installations can proven design really mean anything. This is the true test. This is the test that the American-BFV® has passed repeatedly in installations throughout the world since 1971.

PREFERRED FEATURES

The American-BFV® provides the features that engineers and users have requested and included in the AWWA C504 Butterfly Valve standard. The American-BFV® is designed to provide long life and trouble-free performance. If maintenance becomes necessary, the valve is also designed for easy field service. The shaft seal incorporates V-type packing which is easily replaced in the field without removal from the line. Adjustment of the resilient seat is easily performed

with a socket wrench...no two-part epoxy or urethane to mix...no hypodermic needles to special order. The unique Tri-Loc™ seat retention system assures seat integrity by securing the seat through three different mechanical methods to assure long-term dependable service. (See Figure 1)

The American-BFV® is supplied standard with ductile iron discs in all sizes. The added strength allows the disc design to have a smaller cross section providing improved headloss characteristics. Rest assured that the disc will withstand the flow and pressure transients to which the valves are typically subjected.

SEAT ADJUSTMENT

The American-BFV® Tri-Loc™ system makes both seat adjustment and replacement a snap. Simply remove the cap screws and replace the seat. It's that simple, and it only requires a socket wrench to do it.

Other valves on the market have bonded rubber seats which cannot be adjusted and must be returned to the factory for replacement. Body seats using epoxy require specially ordered hypodermic needles for seat adjustment. Replacement requires pressurized systems to inject the two part epoxy behind the seat.

Figure 1. Tri-Loc™ Seat Retention System

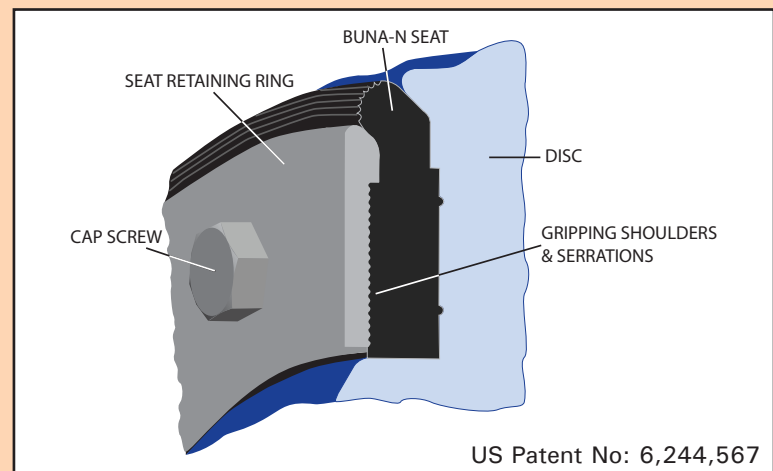

The Tri-Loc™ seat retention system provides positive mechanical retention of the valve seat while allowing easy adjustment or replacement.

The seat is secured by three methods: clamp force, through the seat bolting and opposing machined registers in the disc and seat retaining ring. Clamp force is provided by tightening the Nylok* cap screws. Tightening the screws applies pressure to the serrated seat retaining ring which in turn creates a "clamp force" on the Buna-N molded seat. These same cap screws provide through-bolting seat retention by passing through precision molded holes in the Buna-N seat. Finally, molded shoulders in the Buna-N seat are captured by machined registers in the disc and retention ring preventing outward movement of the seat.

The Tri-Loc™ system has been field proven since 1971 in thousands of installations. In fact, there has never been a reported instance of an American-BFV® Butterfly Valve resilient seat problem due to retention failure.

*Nylok is a registered trademark of Nylok corporation.

VALVE CONSTRUCTION

PRESSURE RATINGS

MAXIMUM PRESSURE RATINGS			
SERIES	CONNECTION	AWWA Class	CWP (psig)
2000	ANSI 125# Gray Iron Flange	150B	150
2100	AWWA MJ Gray Iron	150B	150
2200	ANSI 250# Ductile Iron Flange	250B	250
2300	AWWA MJ Ductile Iron	250B	250
2400	ANSI 125# Ductile Iron Flange	250B	250
2500	ANSI 125# Gray Iron Wafer	150B	150
2600	ANSI 125# FLG x MJ Gray Iron	150B	150

MATERIALS OF CONSTRUCTION

COMPONENT	STANDARD	OPTIONAL
150B Body	Cast Iron ASTM A126, Class B	Ductile Iron ASTM A536 Gr. 65-45-12
250B Body	Ductile Iron ASTM A536 Gr. 65-45-12	Consult Factory
Disc	Ductile Iron ASTM A536 Gr. 65-45-12	Consult Factory
150B Shaft	Stainless Steel ASTM A276 Type 304	Stainless Steel ASTM A276 Type 316
250B Shaft	Stainless Steel ASTM A564 Type 630, H1150	Consult Factory
Resilient Seat	Buna-N	EPDM, Viton
Shaft Bearings 2" - 24"	Nylatron	Teflon
Shaft Bearings 30" and Larger	Teflon-Lined, Fiberglass-Backed	Consult Factory
Body Seat and Hardware	T316 Stainless Steel	Consult Factory
Interior Coating	NSF 61 Epoxy	Fusion Bonded Epoxy
Exterior Coating	Universal Primer	Fusion Bonded Epoxy

FLOW COEFFICIENTS

SIZE	3	4	6	8	10	12	14	16	18
Cv	380	590	1,430	2,750	4,300	6,550	8,350	11,800	15,000

SIZE	20	24	30	36	42	48	54	60
Cv	18,600	27,000	42,000	61,900	87,100	114,000	144,000	180,000

SIZE	66	72	78	84	90	96	102	108
Cv	221,000	266,500	316,000	366,000	420,500	478,500	540,000	605,500

HEADLOSS CHART

CUBIC METERS PER HOUR

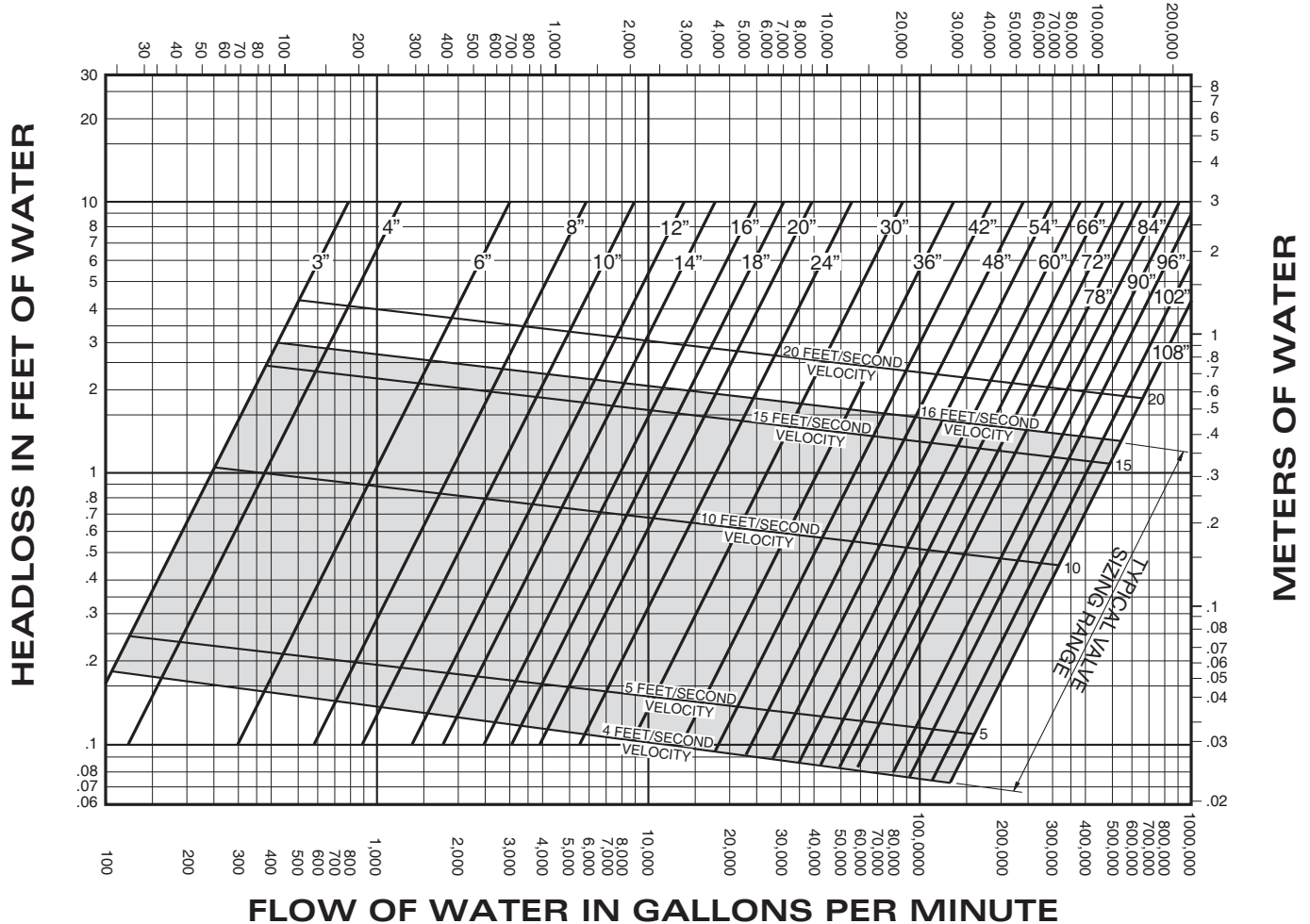

A valve actuator must be able to perform to the same level as the valve. American-BFV® gears are designed and built to provide the same long term service as the American-BFV® Butterfly Valve. Both Traveling Nut (slotted, link/lever) and Worm Gear types are available. Both are designed per AWWA C504 and meet or exceed all material and performance

requirements. The American-BFV® Traveling Nut actuators are designed to withstand 450 ft./lbs. of input torque against both closed and open stops. Buried service gears are grease packed and sealed. American-BFV® gears can be provided with handwheels, chainwheels, or 2" operator nuts. Electric and cylinder actuators are also available.

WORM GEAR

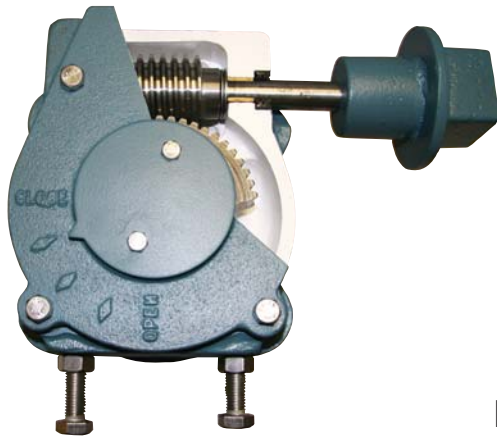

SLOTTED LEVER



LINK AND LEVER

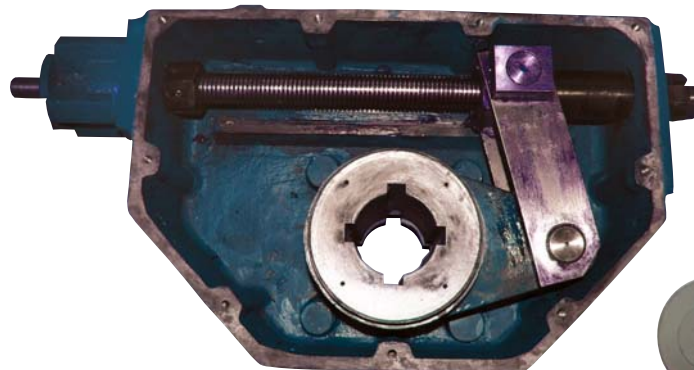

CYLINDER



ELECTRIC ACTUATOR



INSTALLATION DIMENSIONS

FLANGED END CONNECTION

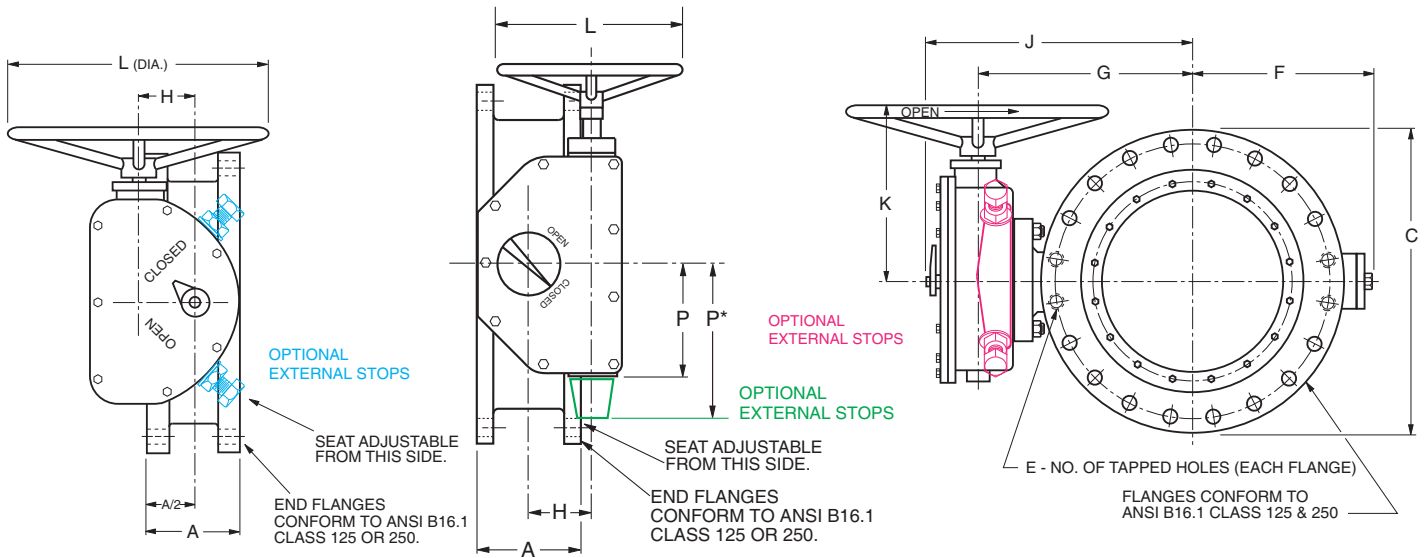

3" - 24"

Actuator Orientation

30" - 36"

Actuator Orientation

Dimensions in Inches														
Valve Size	Pressure Class	A	C	E	F	G	H	J	K	L	P	Turns to Open	Actuator Size	Weight
3	150B	5.00	7.50	4	6.00	7.56	1.50	9.62	9.38	8	-	15	LS-1	66
	250B	5.62	8.25	8										75
4	150B	5.00	9.00	0	6.00	7.56	1.50	9.62	9.38	8	-	15	LS-1	71
	250B	5.62	10.00											80
6	150B	5.00	11.00	4	7.00	8.25	1.50	10.38	9.38	8	-	15	LS-1	90
	250B	5.88	12.50			8.50								130
8	150B	6.00	13.50	0	8.00	9.18	1.50	11.25	9.38	8	-	15	LS-1	125
	250B	7.00	15.00			9.75								145
10	150B	8.00	16.00	0	10.00	11.69	2.00	14.12	10.38	12	-	20	LS-2	200
	250B	9.38	17.50											225
12	150B	8.00	19.00	0	11.06	12.75	2.00	15.25	10.38	16	-	20	LS-2	250
	250B	9.50	20.50			13.00								300
14	150B	8.00	21.00	0	13.50	15.69	3.50	19.00	15.06	24	-	35	LS-3	400
	250B	9.50	23.00											4
16	150B	8.00	23.50	0	14.62	16.69	3.50	20.00	15.06	24	-	35	LS-3	480
	250B	9.62	25.50											4
18	150B	8.00	25.00	4	15.50	18.12	5.00	21.62	18.25	24	-	50	LS-4	640
	250B	9.62	28.00											750
20	150B	8.00	27.50	4	17.50	20.12	5.00	23.62	18.25	24	-	50	LS-4	775
	250B	9.62	30.50											900
24	150B	8.00	32.00	4	20.50	23.12	5.00	26.62	18.25	24	-	50	LS-4	1085
	250B	9.75	36.00											30
30	150B	12.00	38.75	4	27.38	29.12	8.50	34.50	31.00	24.00	14.25	63	LS-5	2435
	250B	13.75	43.00											2800
36	150B	12.00	46.00	4	29.50	31.88	8.50	37.25	31.00	24.00	14.25	63	LS-5	3425
	250B	14.00	50.00											4000

Notes:

Flange drilling conforms to ANSI B16.1, Class 125 or Class 250.
Consult factory for Worm Gear dimensions.

INSTALLATION DIMENSIONS

FLANGED END CONNECTION

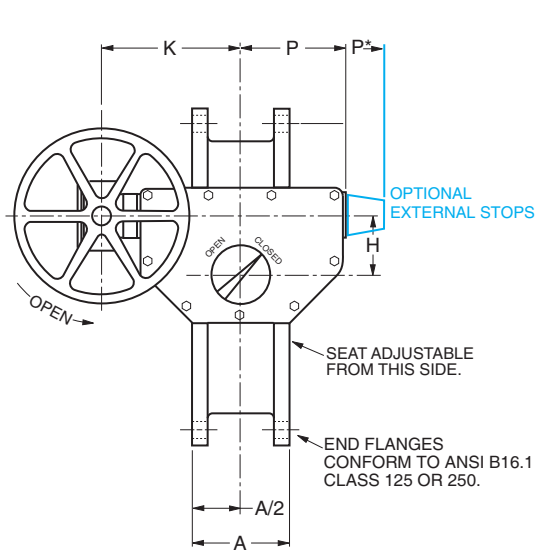

42" - 90"
Actuator Orientation

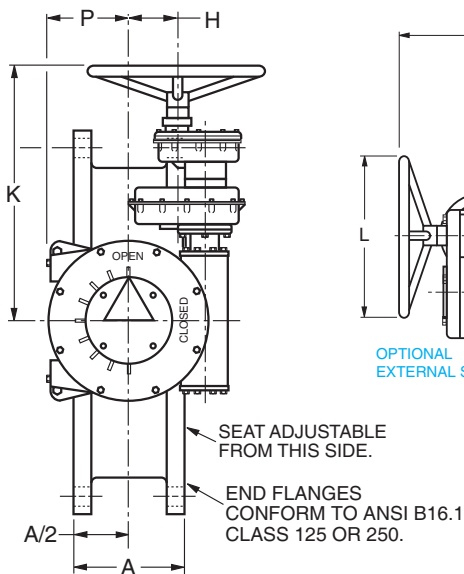

96" - 108"
Actuator Orientation

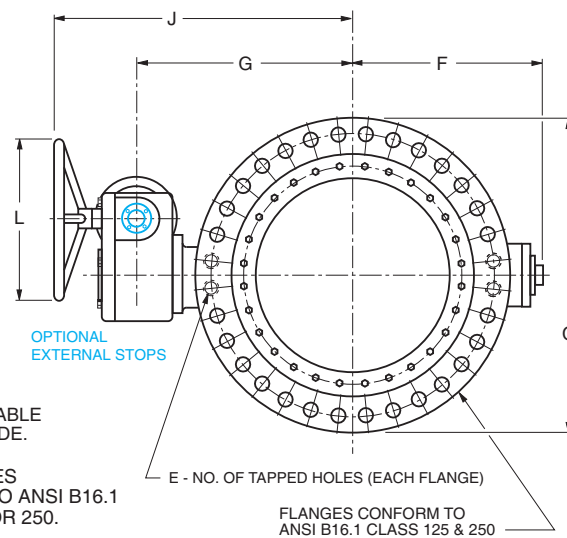

Dimensions in Inches														
Valve Size	Pressure Class	A	C	E	F	G	H	J	K	L	P	Turns to Open	Actuator Size	Weight
42	150B	12.00	53.00	4	35.25	35.88	8.50	49.50	19.50	24.00	14.25	187	LS-5.2	4544
	250B	14.12	57.00											5200
48	150B	15.00	59.50	4	39.31	41.44	10.50	57.75	24.88	24.00	17.62	290	LS-6	6925
	250B	17.50	65.00											8100
54	150B	15.00	66.25	8	44.25	45.44	10.50	61.75	24.88	24.00	17.62	290	LS-6	9255
60	150B	15.00	73.00	8	48.25	53.12	10.50	70.12	24.88	24.00	17.62	290	LS-6	12880
66	150B	18.00	80.00	8	53.31	59.38	10.50	76.38	24.88	24.00	17.62	290	LS-6	14820
72	150B	18.00	86.50	8	59.00	61.00	14.00	79.25	32.25	24.00	23.38	579	LS-7	17800
78	150B	18.00	93.00	8	54.50	73.63	14.00	94.38	32.25	24.00	23.38	579	LS-7.3	15300
84A	150B	19.00	99.75	8	58.75	76.25	14.00	98.50	32.25	30.00	23.38	579	LS-7.2	16400
90	150B	20.00	106.50	8	62.88	82.50	14.00	105.75	32.25	36.00	23.38	579	LS-7	19700
96	150B	21.00	113.25	8	68.50	72.00	19.69	92.47	50.00	24.00	21.31	-	**	24000
102	150B	24.00	120.00	8	71.70	76.10	19.69	96.57	54.00	30.00	21.31	-	**	28000
108	150B	24.00	126.75	8	75.38	79.53	19.69	100.00	56.00	36.00	21.31	-	**	32000

Notes:

**Consult factory for Worm Gear dimensions.

INSTALLATION DIMENSIONS

MECHANICAL JOINT END CONNECTION

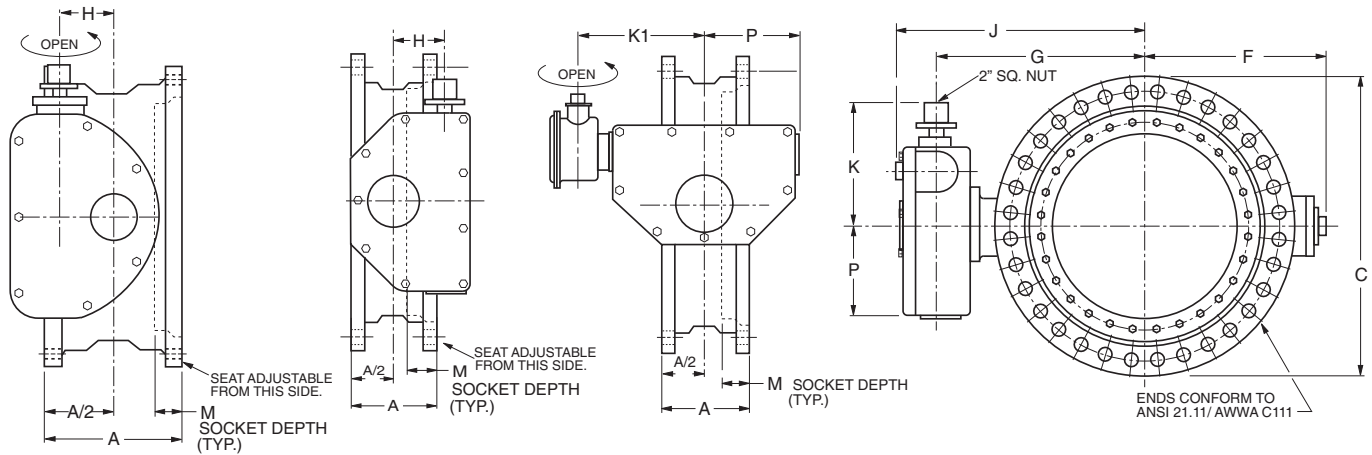

4" - 24"

Actuator Orientation

30" - 36"

Actuator Orientation

42" - 48"

Actuator Orientation

ENDS CONFORM TO ANSI 21.11/AWWA C111

Dimensions in Inches													
Valve Size	Pressure Class	A	C	F	G	H	J	K	K1	M	P	Actuator Size	Weight
4	150B	7.50	9.12	6.00	7.62	1.50	9.62	7.62	-	2.50	-	LS-1	90
	250B												
6	150B	8.00	11.12	7.03	8.25	1.50	10.25	7.62	-	2.50	-	LS-1	135
	250B												
8	150B	8.25	13.37	8.00	9.18	1.50	11.25	7.62	-	2.50	-	LS-1	190
	250B												
10	150B	8.50	15.68	10.00	11.68	2.00	14.12	8.62	-	2.50	-	LS-2	265
	250B												
12	150B	8.62	17.93	11.06	12.75	2.00	15.25	8.62	-	2.50	-	LS-2	345
	250B												
14	150B	11.37	20.31	13.50	15.68	3.50	19.12	12.06	-	3.50	-	LS-3	560
	250B												
16	150B	11.62	22.56	14.62	16.75	3.50	20.12	12.06	-	3.50	-	LS-3	670
	250B												
18	150B	12.00	24.81	15.50	18.18	5.00	21.87	13.75	-	3.50	-	LS-4	875
	250B												
20	150B	12.50	27.12	17.50	20.18	5.00	23.87	13.75	-	3.50	-	LS-4	1070
	250B												
24	150B	13.00	31.56	20.50	23.18	5.00	26.87	13.75	-	3.50	-	LS-4	1395
	250B												
30	150B	18.12	39.12	27.37	29.18	8.50	35.00	19.50	-	4	14.25	LS-5	2480
	250B												
36	150B	19.25	46.00	29.50	31.87	8.50	37.75	19.50	-	4	14.25	LS-5	3775
	250B												
42	150B	19.75	53.12	35.25	35.87	8.50	41.75	17.50	19.50	4	14.25	LS-5.2	5800
	250B												
48	150B	21.31	60.00	39.31	41.50	10.50	50.25	22.25	24.87	4	17.62	LS-6	8600
	250B												

Notes:

Mechanical Joint (MJ) end connection conform to ANSI/AWWA A21.11/C111.

INSTALLATION DIMENSIONS

FLANGE X MECHANICAL JOINT END CONNECTION

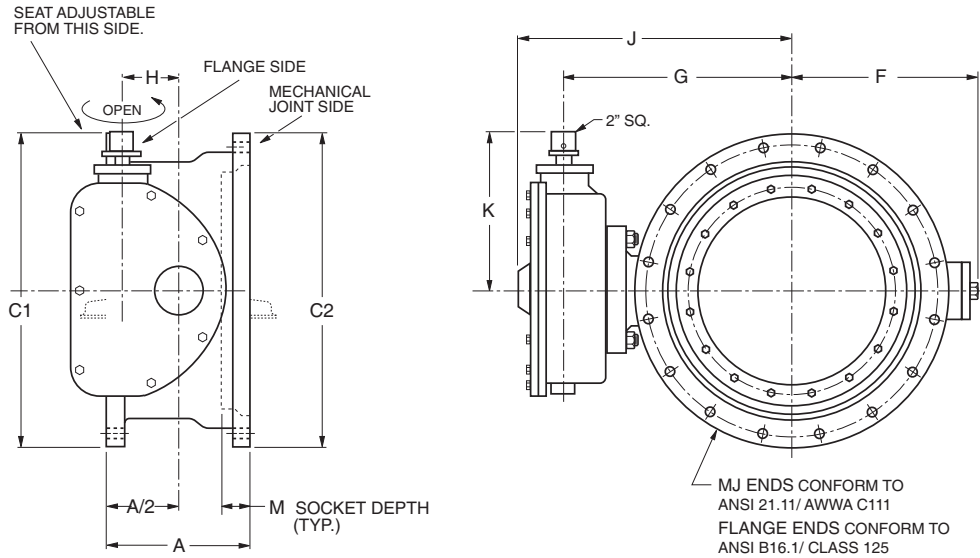

Dimensions in Inches												
Valve Size	Pressure Class	A	C1	C2	F	G	H	J	K	M	Actuator Size	Weight
6	150B	6.75	11.00	11.12	7.03	8.25	1.50	10.25	7.62	2.50	LS-1	110
8	150B	7.50	13.50	13.38	8.00	9.18	1.50	11.25	7.62	2.50	LS-1	165
12	150B	8.62	19.00	17.94	11.06	12.75	2.00	15.25	8.62	2.50	LS-2	300
16	150B	10.00	23.50	22.56	14.62	16.75	3.50	20.12	12.06	3.50	LS-3	600

WAFER END CONNECTION

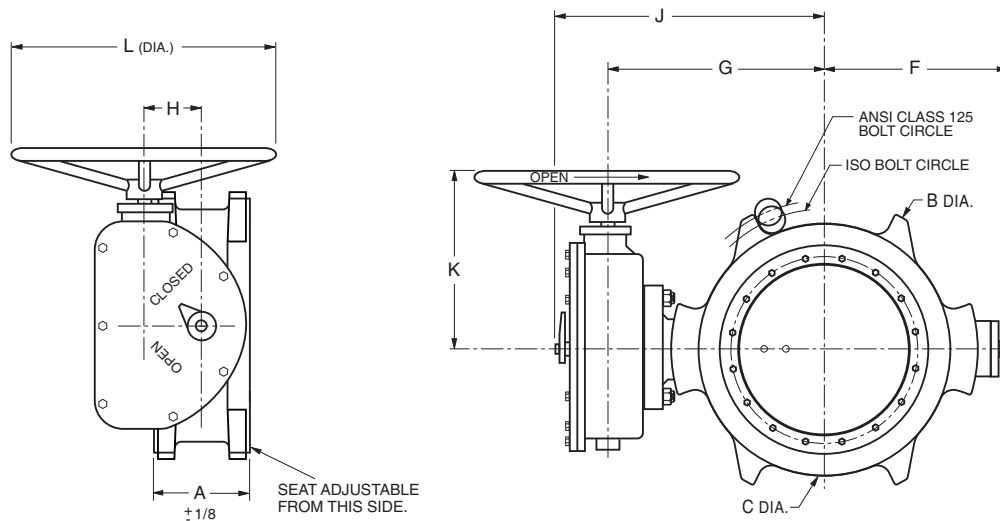

Dimensions in Inches													
Valve Size	Pressure Class	A	B	C	F	G	H	J	K	L	Turns to Open	Actuator Size	Weight
4	150B	2.25	7.88	6.41	6.00	7.56	1.50	9.62	9.38	8	15	LS-1	48
6	150B	2.81	9.70	8.59	7.00	8.25	1.50	10.38	9.38	8	15	LS-1	64
8	150B	2.94	12.50	10.75	8.00	9.18	1.50	11.25	9.38	8	15	LS-1	70
10	150B	3.13	14.75	12.94	10.00	11.69	2.00	14.12	10.38	12	20	LS-2	110
12	150B	3.38	17.38	14.88	11.06	12.75	2.00	15.25	10.38	16	20	LS-2	125

Notes:

Mechanical Joint (MJ) end connection conform to ANSI/AWWA A21.11/C111.

ACCESSORIES

Space limitations and application specifics often require special accessories. In addition to those shown below, Val-Matic offers a wide range of accessories to meet your application requirements. Please consult factory for assistance.

Extension Stem Assembly

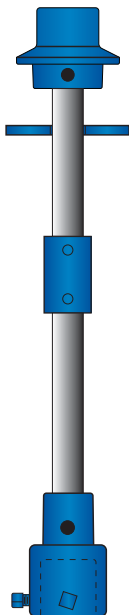

Chainwheel

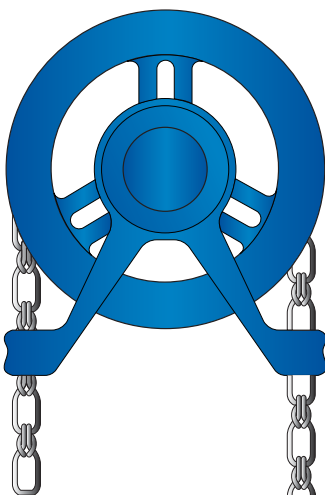

Valve Box

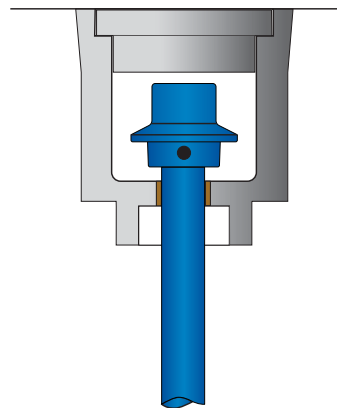

"T" Wrench

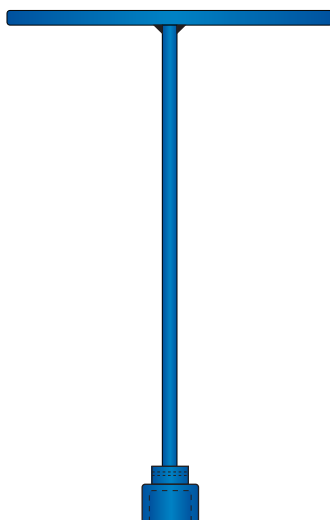

Extended Bonnet

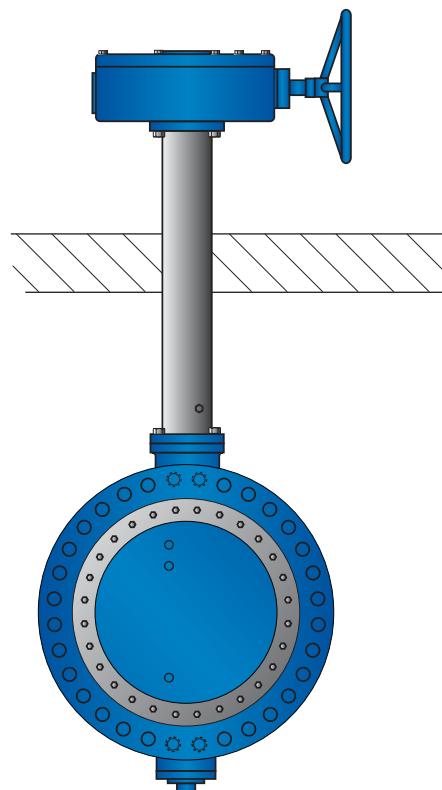

Floor Stand

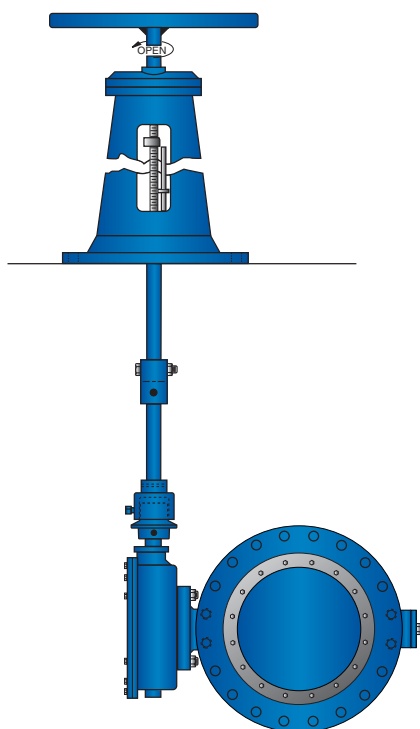

Stem Guide

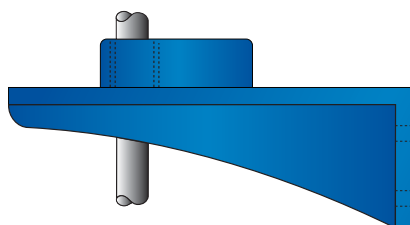

SCOPE

- 1.1 This specification is designed to cover the design, manufacture, and testing of AWWA Class 150B (3"-108") and AWWA Class 250B (4"-48") butterfly valves.

STANDARDS AND APPROVALS

- 2.1 The valves shall be designed, manufactured and tested in accordance with American Water Works Association Standard ANSI/AWWA C504.
- 2.2 Valves shall be proof of design tested in accordance with ANSI/AWWA C504, and certified to NSF/ANSI 61 Drinking Water System Components - Health Effects.
- 2.3 Manufacturer shall have a quality management system that is certified to ISO 9001:2008 by an accredited, certifying body.

CONNECTIONS

- 3.1 Flanged end connections shall fully conform with ANSI B16.1 for Class 125, Class 250 iron flanges, or AWWA C207 Class D. Both 125 and 250 flanges shall be flat faced.
- 3.2 Mechanical Joint end connections shall fully conform with ANSI/AWWA C111/A21.11.3.3 Wafer end connections shall be designed for installation between ANSI B16.1 Class 125 iron flanges or between ISO7005-2 PN10 or PN16 flanges.

DESIGN

- 4.1 Valve shafts shall be of the through-type for sizes 3"-24". 30" and larger shall be of the stub type design. Shafts shall be locked to the disc by O-Ring sealed taper pins retained with stainless steel nuts. Through-type shafts shall be supplied on 30" and larger valves when specified.
- 4.2 Valve Discs shall be of the solid type without external ribs or vanes to obstruct flow.
- 4.3 Resilient seats shall be located on the valve disc and shall provide a 360° continuous, uninterrupted seating surface. Seats shall be mechanically retained with a stainless steel retaining ring and stainless steel Nylok® cap screws which shall pass through both the resilient seat and the retaining ring. The retaining ring shall be continuous or investment cast with overlapping sections, serrated grooves, and shoulders providing a Tri-Loc™ system. The resilient seat's mating surface shall be to a 360° continuous, uninterrupted stainless steel body seat ring. Resilient seats shall be field adjustable and replaceable and shall not require hypodermic needles or pressure vessels to replace or adjust.

- 4.4 Sleeve bearings shall be provided in the valve hubs and shall be nylatron or woven teflon, fiberglass backed. They shall be self-lubricating.
- 4.5 Thrust bearings shall be provided and shall be adjustable on valves 30" and larger.
- 4.6 Shaft seals shall be of the V-type and shall be replaceable without removal of the valve from the line or the shaft from the valve.

MATERIALS

- 5.1 Body: Class 150B valve bodies shall be ASTM A126, Class B gray iron or ASTM A536 Grade 65-45-12 ductile iron. Class 250B valve bodies shall be ASTM A536 Grade 65-45-12 ductile iron.
- 5.2 Disc: Valve disc shall be ASTM A536 Grade 65-45-12 ductile iron.
- 5.3 Shafts: Shafts shall be ASTM A276 type 304, or ASTM A564, Type 630 Stainless Steel.
- 5.4 Seat: Resilient seat shall be Buna-N and mate to a Type 316 Stainless Steel body seat ring.
- 5.5 Hardware: All seat retaining hardware shall be Type 316 stainless steel.

ACTUATION

- 6.1 Manual, electric or cylinder actuation shall be provided as specified.

OPTIONS

- 7.1 Optional body material is ASTM A536, Grade 65-45-12 ductile iron.
- 7.2 Optional shaft material is ASTM A276, Type 316 stainless steel.

MANUFACTURE

- 8.1 Valve exteriors for above ground service shall be coated with a universal, alkyd primer. Valve exteriors for buried service shall be coated with an epoxy coating. Valve interiors shall be coated with an NSF/ANSI 61 epoxy coating approved for potable water. Fusion bonded epoxy shall be supplied on the exterior and interior when specified.
- 8.2 Valve shall be Val-Matic® Series 2000 or equal.

Nylok® is a registered trade mark of the Nylok Fastener Corporation.

VAL-MATIC®

Val-Matic's quality of design and meticulous workmanship has set the standards by which all others are measured. Quality design features such as Type 316 stainless steel trim as standard on Air Release, Air/Vacuum and Combination Air Valves.....combined resilient/metal to metal seating for Silent Check Valves... stabilized components that provide extended life of the Dual Disc® Check Valves... high strength and wear resistant aluminum bronze trim as standard for Tilted Disc® Check Valves... unrestricted full flow area through Swing-Flex® and Surgebuster® Check Valves... heavy duty stainless steel screened inlet on Sure Seal Foot Valves... a Cam-Centric® Plug Valve with more requested features than any other eccentric plug valve... the American-BFV® Butterfly Valve that provides field replaceable seat without the need for special tools... an Ener•G® efficient AWWA Ball Valve with fusion bonded epoxy and adjustable resilient seating and the VaultSafe® family of products includes the FloodSafe® Inflow Preventer, FrostSafe® two-way damper and the VentSafe® vent pipe security cage. These features coupled with our attention to detail put Val-Matic Valves in a class by themselves.

Val-Matic is totally committed to providing the highest quality valves and outstanding service to our customers. Complete customer satisfaction is our goal.

Make the Change to Quality!

Specify

VAL-MATIC®

Val-Matic Valve and Manufacturing Corp.
905 Riverside Drive, Elmhurst, IL 60126
Phone: 630-941-7600 Fax: 630-941-8042
www.valmatic.com
valves@valmatic.com

Copyright © 2010 Val-Matic Valve & Mfg. Corp.
ISO 9001:2008 certified company

