

Existing View

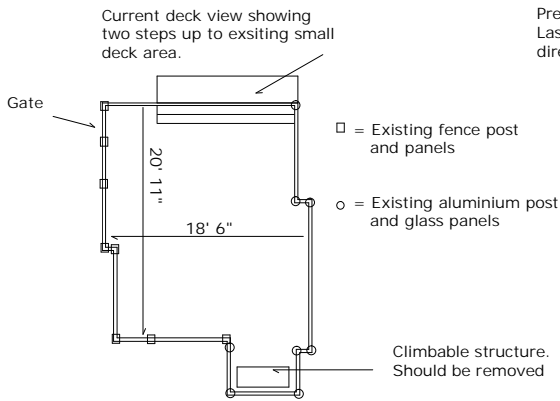

Framing View

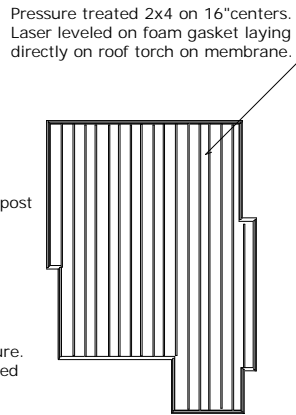

Decking View

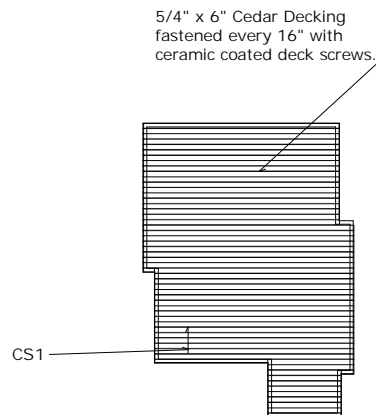

Proposed View

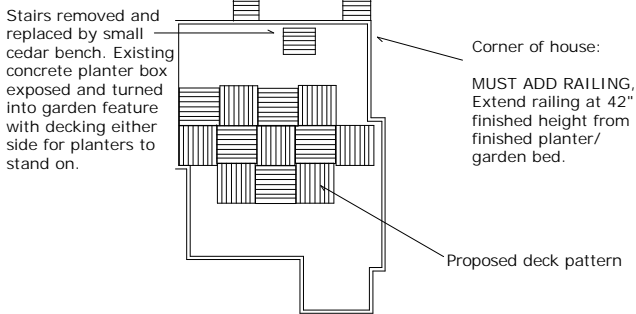

CS1: Cross Section 1 Drawing:

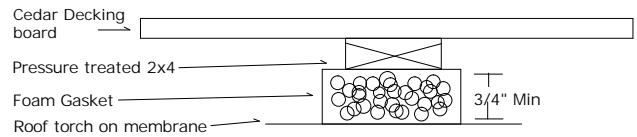

NO.	DESCRIPTION	BY	DATE
SHEET TITLE			
Top Views			
PROJECT DESCRIPTION			
Croslyn & Jon #901 1237 Dabbess Avenue City West Vancouver V7V 1P8			
DRAWING PROVIDED BY			
Cedar Creek Contracting Ltd 1732 Lily / 275/563 Maple 604-476-2834			
DATE:			
4/23/2015			
NOT TO SCALE			
SHEET:			
S-1			