

DETAIL A

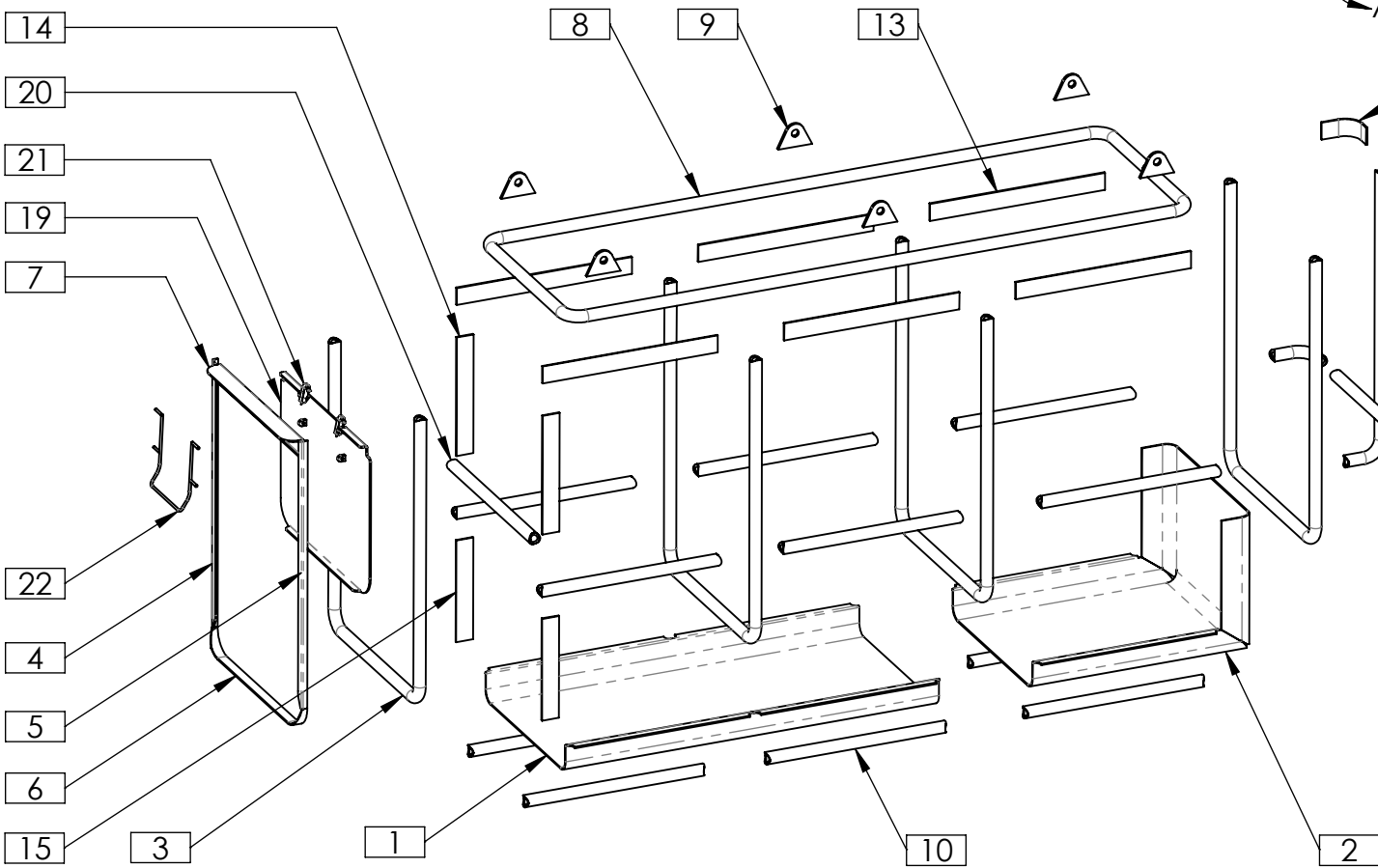

#	PART NUMBER	Q.
1	BB 2rnd - bottom tray - F	1
2	BB 2rnd - bottom tray - R	1
3	BB 2rnd - bottom U	4
4	BB 2rnd - door frame - h angle	1
5	MirrorBB 2rnd - door frame - h angle	1
6	BB 2rnd - door frame - bottom - U	1
7	BB 2rnd - door frame - top channel	1
8	BB 2rnd - top ring	1
9	BB 2rnd - lift lugs x6	6
10	BB 2rnd - center tubes	12
11	BB 2rnd - rear L	2
12	BB 2rnd - corner	2
13	BB 2rnd - support strap	6
14	BB 2rnd - support strap v1	2
15	BB 2rnd - support strap v2	2
16	BB 2rnd - support strap corner	2
17	BB 2rnd - support strap - rear	1
18	BB 2rnd - rear horizontal	1
19	BB 2rnd - door	1
20	BB 2rnd - front horizontal	1
21	Clip Hook	2
22	BB 2rnd - door - wire handle	1

[JMB] STAINLESS	JOB NAME: BONE BASKET - BROTH TANK	SALES ORDER / CONTACT: JMB STAINLESS		
	TOLERANCE: +/- 1/16"	MATERIAL: 304 S.S.	MODEL NUMBER: SQ. BONE TANK	REVISION: A
	DRAWN BY: O. W. D.	DATE: Friday, May 13, 2016		