

Part 1 (1 : 2)

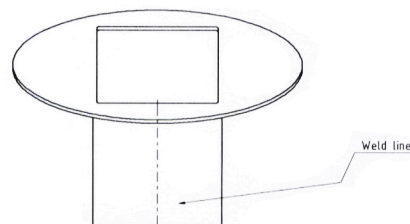

Flat Pattern for
MTS_Base_p1&2

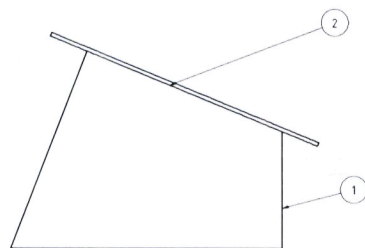
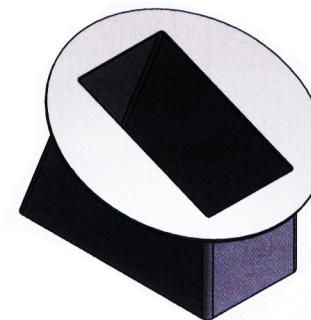
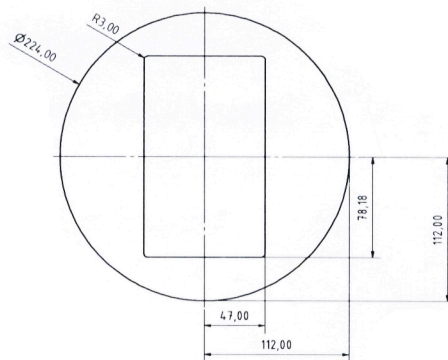
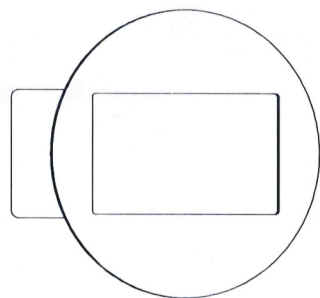
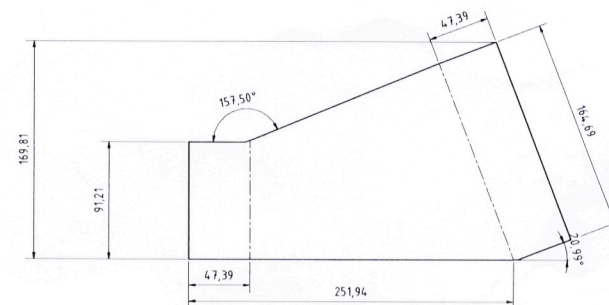

Part 2 - MTS330_Base-p1 (1 : 2)

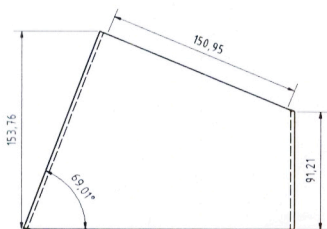
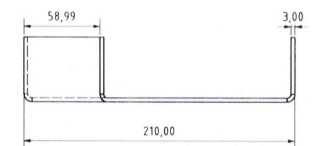

Part2 - MTS330_Base-p2 (1 : 2)

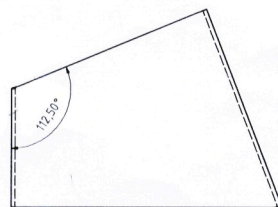

PARTS LIST				
ITEM	QTY	PART NUMBER	DESCRIPTION	MATERIAL
1	1	MTS330_Base	Sheet metal 3mm	Default
2	1	MTS330_flange_V2	Sheet metal 3mm	Default

Projection		Project	
Author	engin-alg	Title	
Scale	1:2	Format	A1
Date	9-9-2013	Drawing nr	MTS330
Checked		 MTS330 ENGINEERING Monks Mill BV Parallelweg 4 5451 GW Maastricht www.mts330.nl	