

PARTS LIST			
ITEM	QTY	PART NUMBER	DESCRIPTION
1	1	1-BASE	
2	1	2-SLIDING JAW	
3	2	3-JAW PLATE	
4	1	4-VISE SCREW	
5	1	5-COLLAR	
6	1	6-SPECIAL KEY	
7	2	9-SLIDE KEY	
8	2	10-SET SCREW	
9	4	ANSI B18.6.2 - 1/4-20 UNC x 0.625	Slotted Flat Countersunk Head Cap Screw
10	1	7-HANDLE ROD	
11	2	8-HANDLE BALL	
12	2	#000 TAPER PIN	

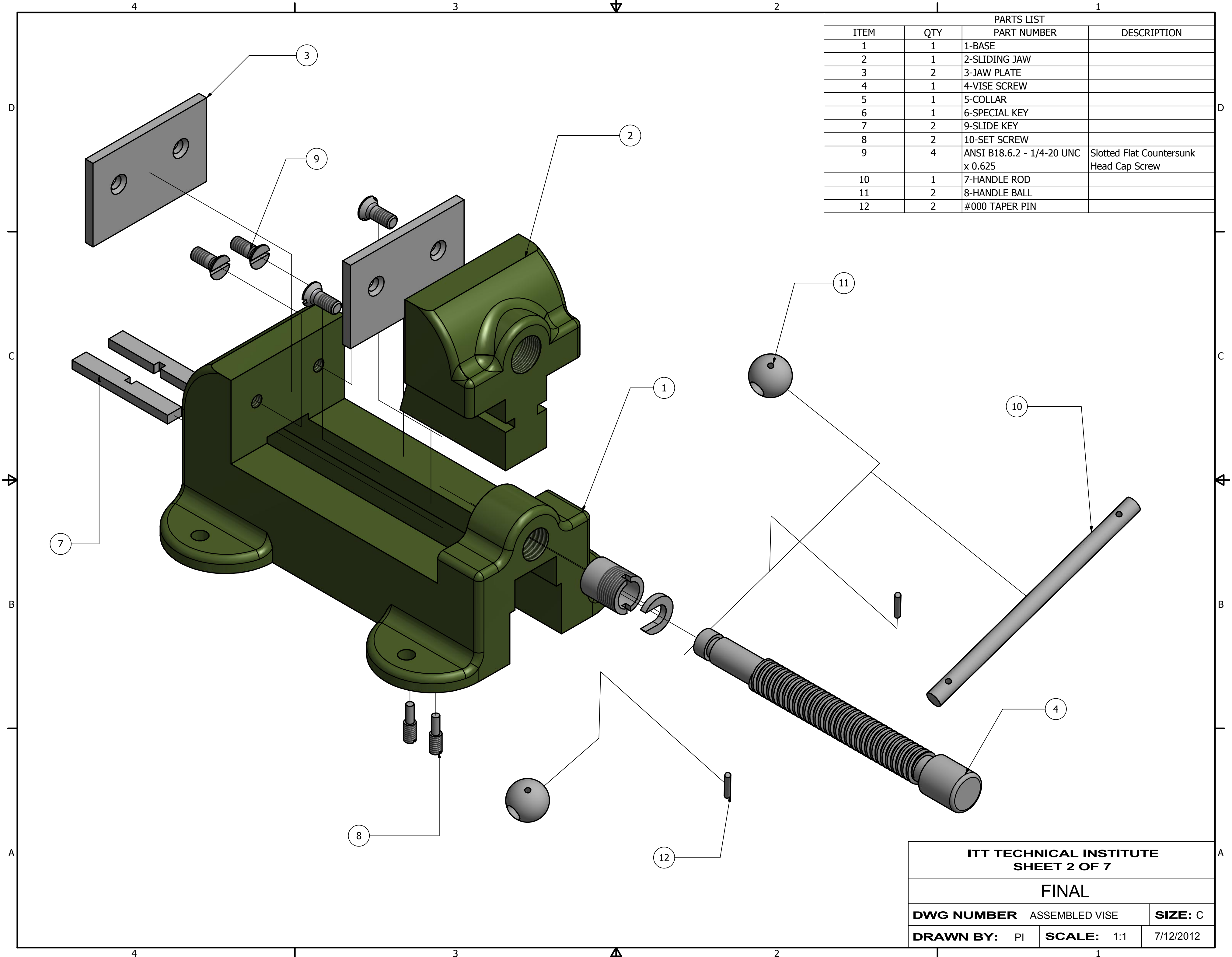

ITT TECHNICAL INSTITUTE		
SHEET 2 OF 7		
FINAL		
DWG NUMBER	ASSEMBLED VISE	SIZE: C
DRAWN BY:	PI	SCALE: 1:1
		7/12/2012

PRODUCED BY AN AUTODESK EDUCATIONAL PRODUCT

PRODUCED BY AN AUTODESK EDUCATIONAL PRODUCT