

# TECNOLOGÍA

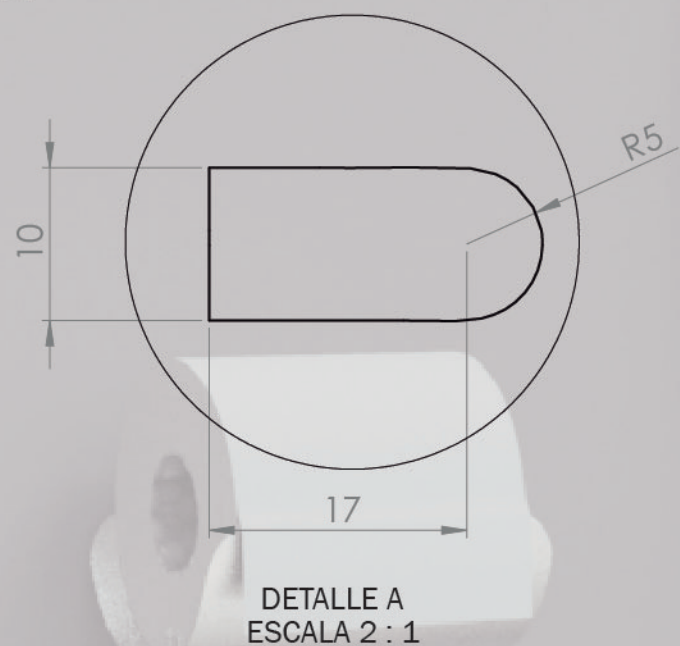

MATERIAL: Aluminio  
 Espesor cte: 2 mm  
 PROCESOS: Corte waterjet, punzonado, curvado y granallado.

# PLANOS

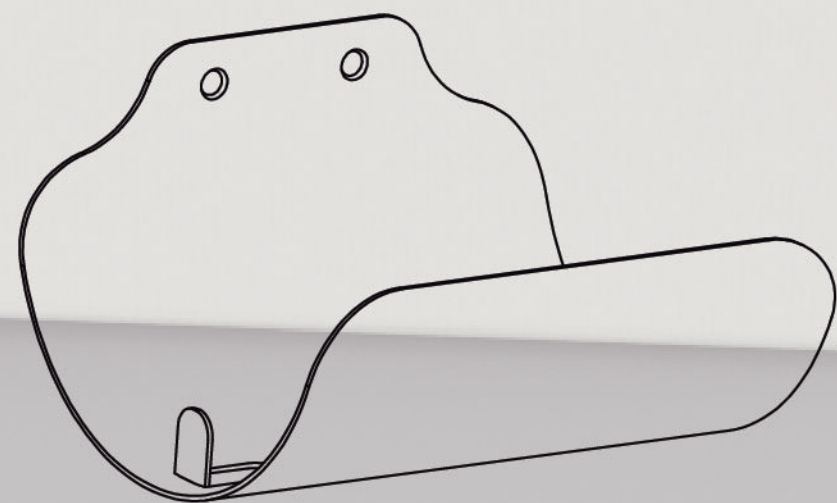
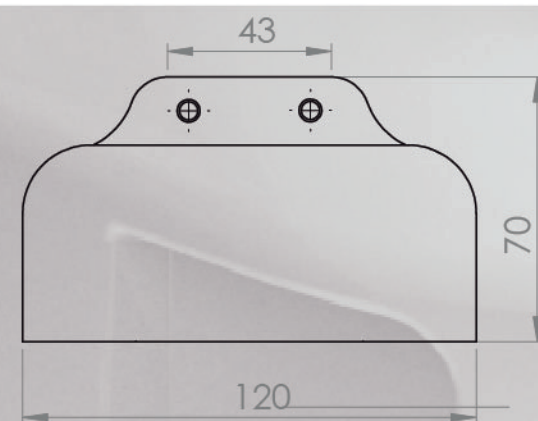
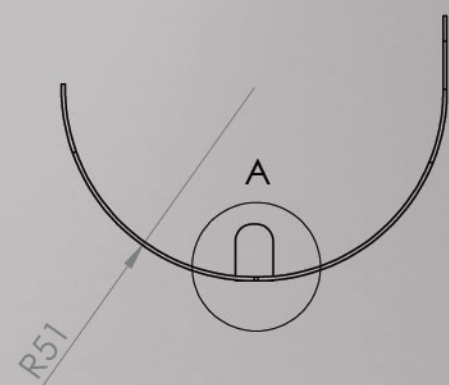
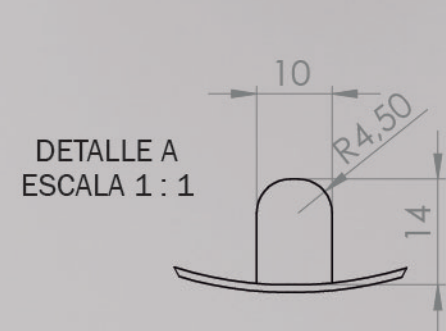

Escala: 1:1

Escala: 1:2

# INSTALACIÓN

## 1



Marcar la posición de los agujeros

## 2

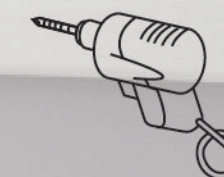

Realizar agujeros con una mecha de diametro 6mm

## 3



Colocar 2 tarugos plásticos

## 4

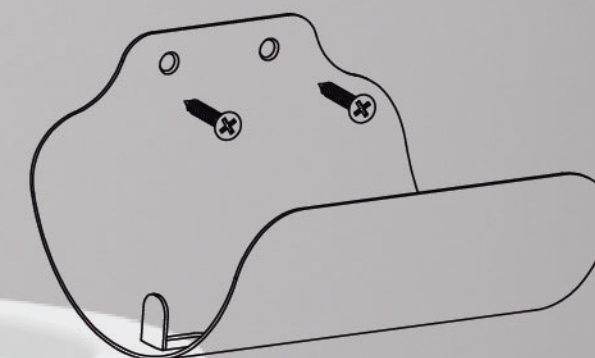

Ubicar el portarollo y atornillarlo

## 5

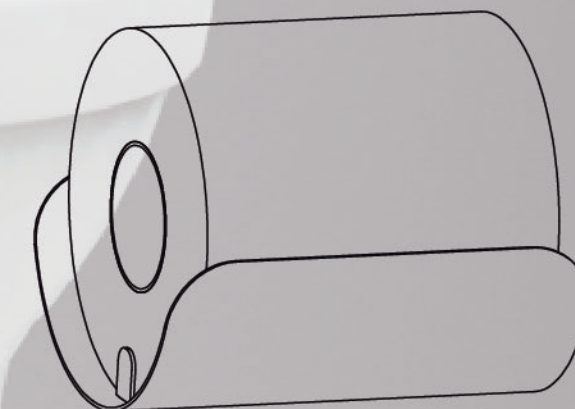

Alumina

