

ALL GLASS PANELS MUST BE
GLUED TO METAL FRAME
USING UV10 GLUE BY MASTERBOND
(WWW.MASTERBOND.COM)

NOTE:
DISPLAY SETUP (SEE SHT 3 OF 3)
1. HANG AND FOLD UNIT (1 TOP SHELF, 3 HANGBARS and 9 FACEOUTS)

13	62000983	22H-03-CG WOOD BASE CABINET 60" X 20' 15" HIGH WITH DRAWERS	2
12	20000182	OPEN CASE DOUBLE FACEOUT 9"	9
11	40000556	22H-02-CG OPEN CASE HANGBAR 56"	1
10	40000554	OPEN CASE SIDE HANGBAR SUPPORT 18-7/8" OC.	6
9	54000254	A22-H-02-CG METAL SHELF 20" X 57"	1
8	39000261	SHELF SUPPORT BRACKET	4
7		FLAT HEAD WOOD SCREW #8 X 2"	16
6	62000982	22H-02-CG GLASS TOP SHELF 1/4" X 19-3/4" X 59-3/4" CLEAR TEMPERED	1
5	62000909	22H-02-CG/22H-03-CG GLASS PANEL 1/4" X 17-5/8" X 71-5/8" CLR. TEMP.	2
4	91255A578	BUTTON HEAD CAP SCREW 5/16-18 X 1/2"	4
3	33001434	22H-02-CG SIDE BOTTOM FRAME	2
2	33001433	22H-02-CG SIDE TOP FRAME	2
1	33001485	22H-02-CG FRONT/BACK METAL FRAME 60" WIDE	2
ITEM	PART No.	DESCRIPTION	QTY.

BILL OF MATERIALS

UNLESS OTHERWISE SPECIFIED, DIMENSIONS ARE INCHES. TOLERANCES ARE:		CUSTOMER		 Pico Rivera, CA. (562) 949-2535	
FRACTIONS: +/- 1/32	DECIMALS: .xx +/- .01 .xxx +/- .005	ANGLES: +/- 1/2	FRED SEGAL		
FINISH: POWDER COAT BRASS /BLK LACQ. WOOD BASE			APPROVALS	DATE	TITLE
DO NOT SCALE DRAWING			DRAWN JEL	4/9/2014	22-H-02-CG CUSTOM GLASS CASE 60" WIDE
			CHK'D.		SIZE B
			APVD.		DWG. No. 49001322
			EQCB No.		REV.
			SCALE: N.T.S.		SHEET: 1 OF 3

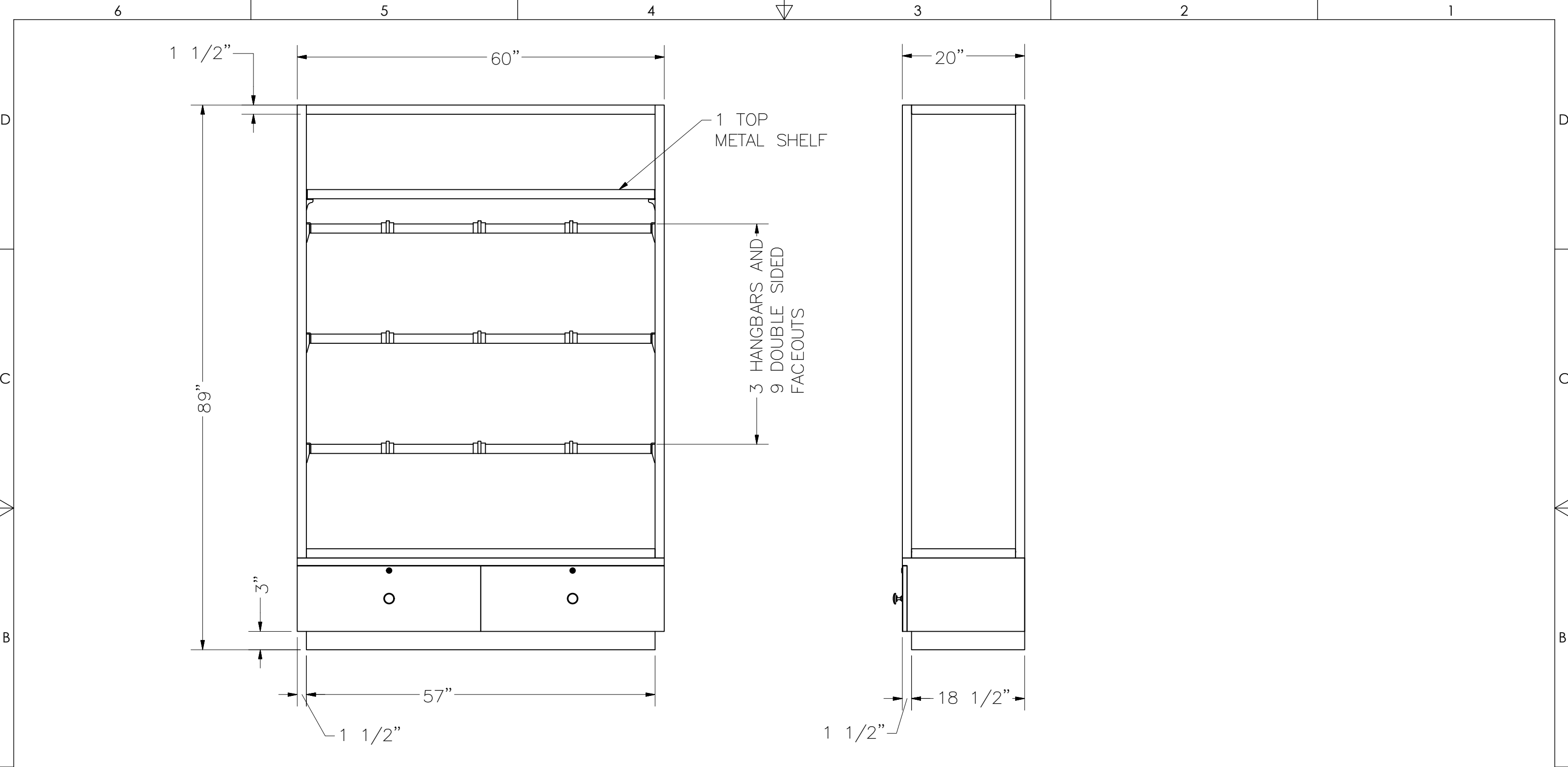

UNLESS OTHERWISE SPECIFIED,
DIMENSIONS ARE INCHES.
TOLERANCES ARE:

FRACTIONS: +/- 1/32	DECIMALS: .xx +/- .01 .xxx +/- .005	ANGLES: +/- 1/2
------------------------	---	--------------------

FINISH POWDER COAT
BRASS /BLK LACQ.
WOOD BASE

DO NOT SCALE DRAWING

CUSTOMER
FRED SEGAL

APPROVALS	DATE
DRAWN JEL	4/9/2014

CHK'D.	
APVD.	
EQCB No.	

REEVE

STORE EQUIPMENT CO.
Pico Rivera, CA. (562) 949-2535

TITLE **22-H-02-CG CUSTOM GLASS CASE 60"
WIDE**

SIZE B	DWG. No. 49001322	REV.
--------	--------------------------	------

SCALE: N.T.S.	SHEET: 2 OF 3
---------------	---------------



DISPLAY SETUP

9

8

10

11

12

UNLESS OTHERWISE SPECIFIED, DIMENSIONS ARE INCHES. TOLERANCES ARE: FRACTIONS: DECIMALS: ANGLES: +/- 1/32 .xx +/- .01 +/- 1/2 .xxx +/- .005 FINISH POWDER COAT BRASS /BLK LACQ. WOOD BASE DO NOT SCALE DRAWING	CUSTOMER		 STORE EQUIPMENT CO. Pico Rivera, CA. (562) 949-2535		TITLE 22-H-02-CG CUSTOM GLASS CASE 60" WIDE	SIZE B	DWG. No. 49001322	REV.
	FRED SEGAL							
	DRAWN	JEL	4/9/2014					
	CHK'D.							
	APVD.							
EQCB No.				SCALE:	N.T.S.	SHEET:	3 OF 3	

THIS DRAWING IS THE EXCLUSIVE PROPERTY OF REEVE STORE EQUIPMENT CO. WHO HOLDS AND MAINTAINS FULL COPYRIGHT PROTECTION UNDER FEDERAL AND STATE LAW. THIS DRAWING CANNOT BE DUPLICATED, PHOTOCOPIED, DIGITALLY TRANSFERRED, OR REPRODUCED WITHOUT THE EXPRESS WRITTEN CONSENT OF REEVE STORE EQUIPMENT CO. COPYRIGHT 2012, 2011, 2010, 2009, 2008, 2007, 2006, 2005, 2004, 2003, 2002. ALL RIGHTS RESERVED.

6 5 4 3 2 1

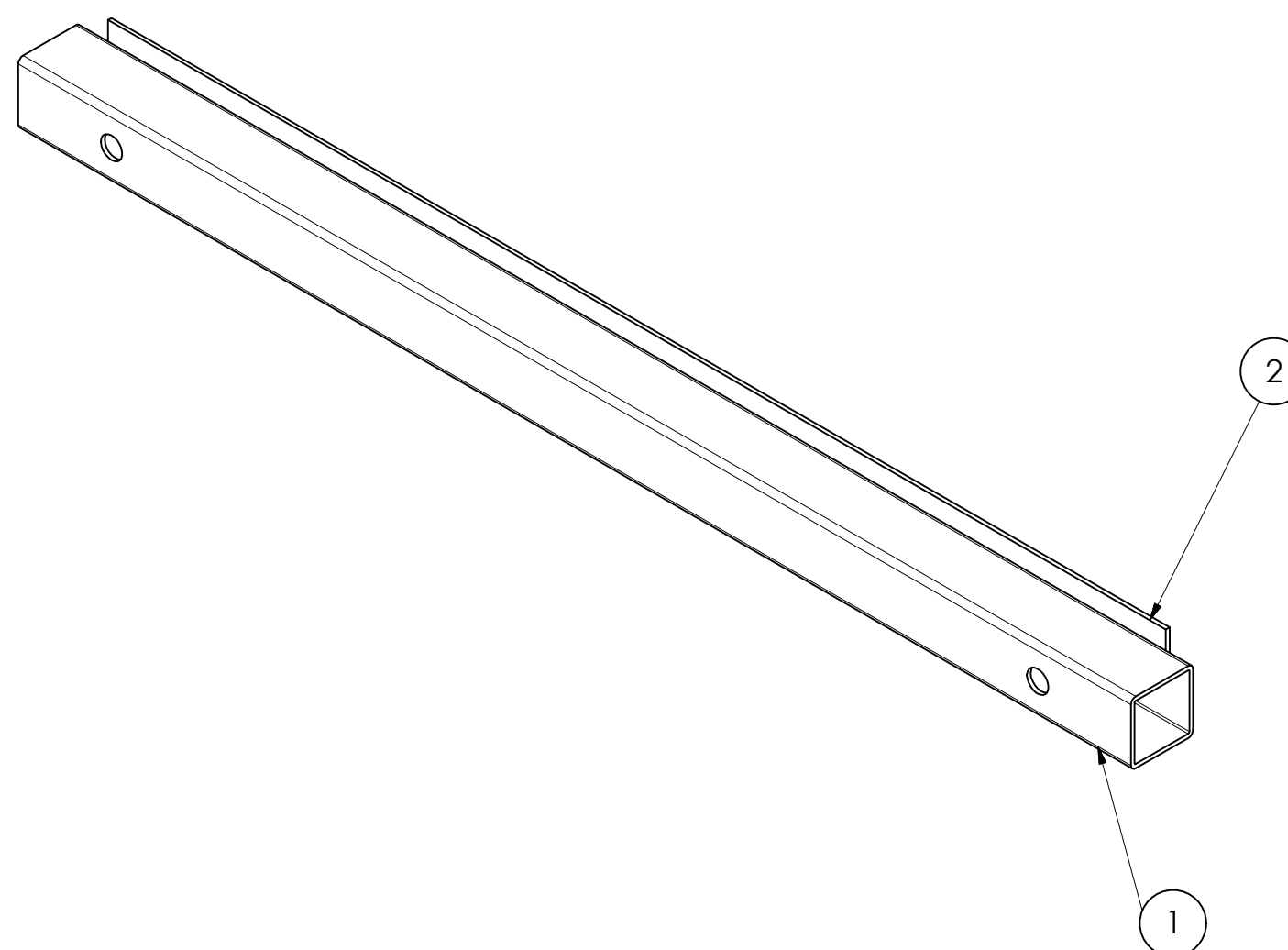
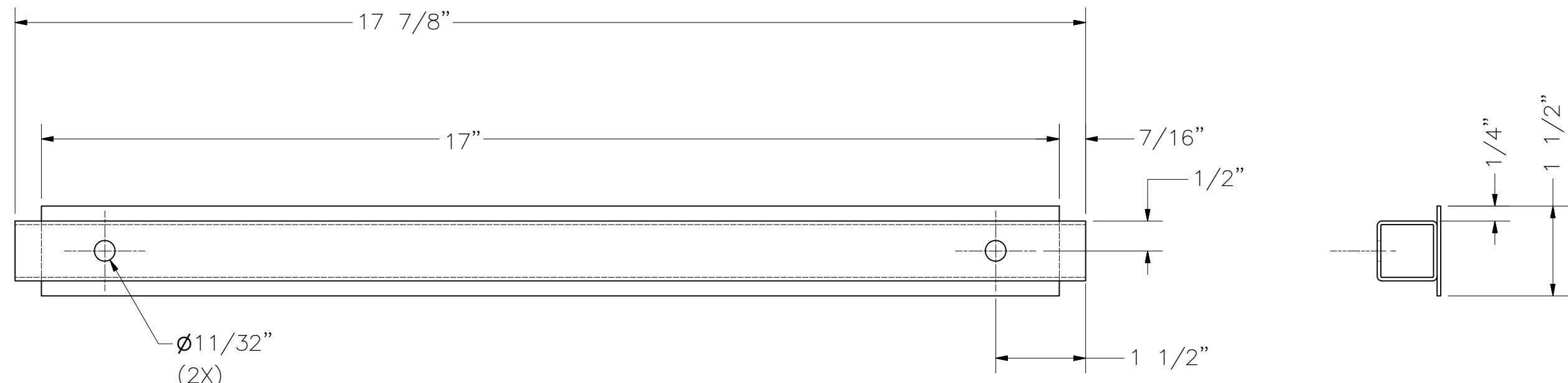

2	R366	METAL SHEET 16GA. X 48" X 120" C.R.S.	1
1	R70	SQ. TUBE 1" 16GA. C.R.S.	1
ITEM	PART No.	DESCRIPTION	QTY.

BILL OF MATERIALS

UNLESS OTHERWISE SPECIFIED,
DIMENSIONS ARE INCHES.
TOLERANCES ARE:

FRACTIONS: +/- 1/32	DECIMALS: .xx +/- .01 .xxx +/- .005	ANGLES: +/- 1/2
------------------------	---	--------------------

FINISH
POLISHED BRASS

DO NOT SCALE DRAWING

CUSTOMER FRED SEGAL	
APPROVALS DRAWN JEL	DATE 4/9/2014
CHK'D.	
APVD.	
EQCB No.	

REEVE
STORE EQUIPMENT CO.
Pico Rivera, CA. (562) 949-2535

TITLE
22H-02-CG SIDE TOP FRAME

SIZE **B** DWG. No. **33001433** REV.

SCALE: **N.T.S.** SHEET: **1 OF 1**

6 5 4 3 2 1

COUNTERSUNK
HOLE FOR
#8 FLAT HD
WOOD SCREW
(3X)

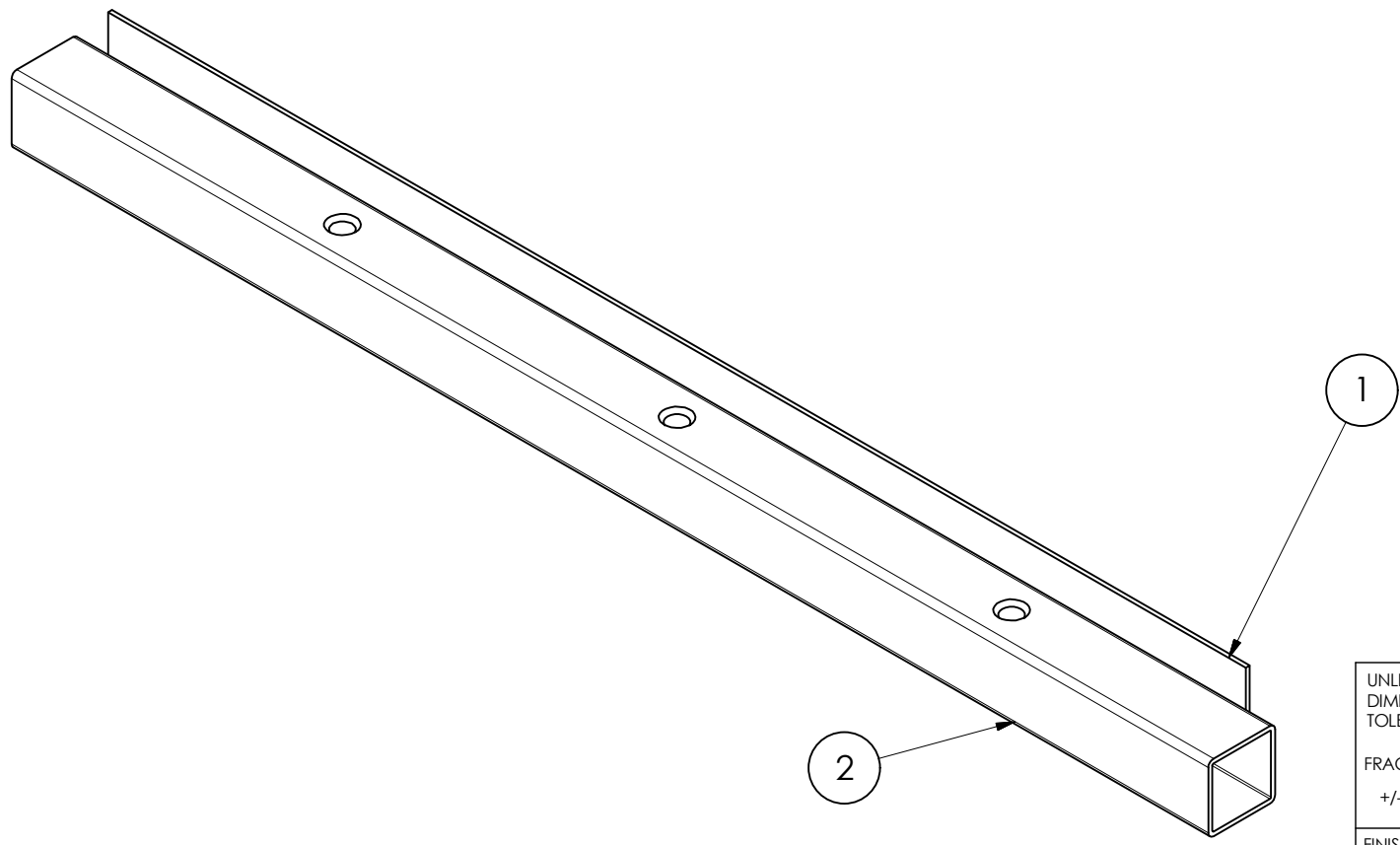
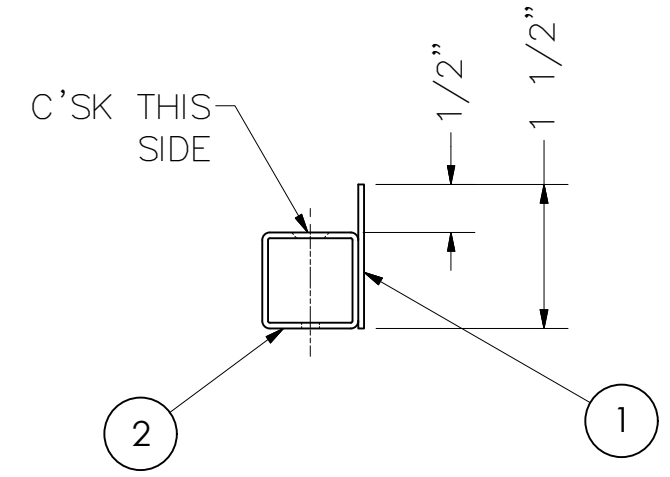
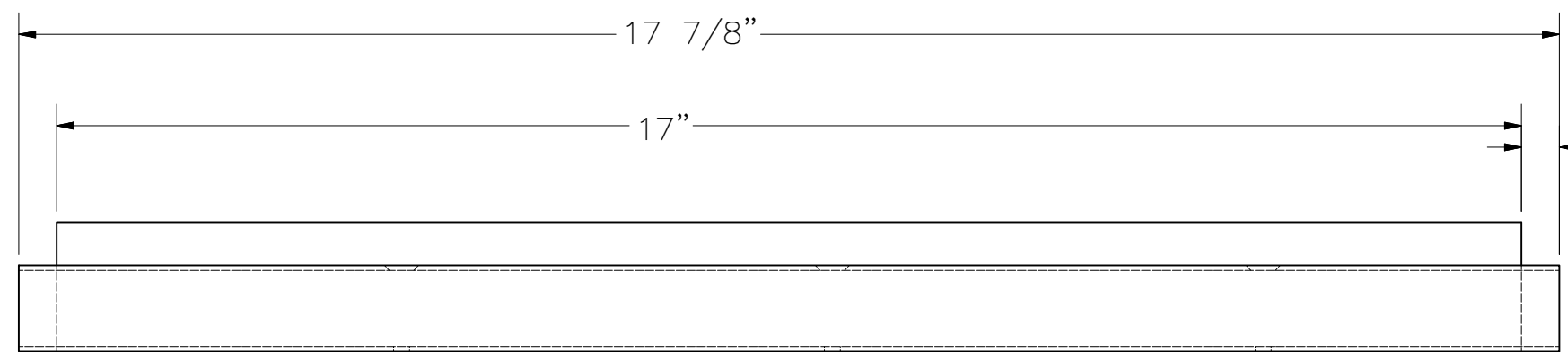
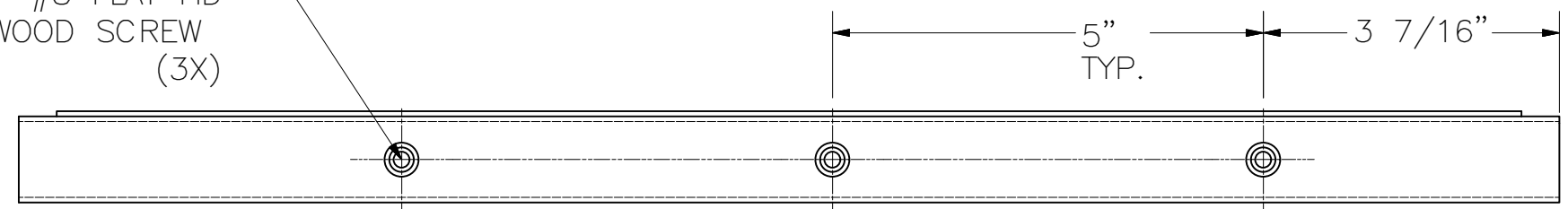

ITEM	PART No.	DESCRIPTION	QTY.
2	R70	SQ. TUBE 1" 16GA. C.R.S.	1
1	R366	METAL SHEET 16GA. X 48" X 120" C.R.S.	1

BILL OF MATERIALS

CUSTOMER FRED SEGAL	
APPROVALS	DATE
DRAWN JEL	4/9/2014
CHK'D.	
APVD.	
EQCB No.	

 Pico Rivera, CA. (562) 949-2535		TITLE	22H-02-CG SIDE TOP FRAME
		SIZE B	
SCALE: N.T.S.		SHEET:	1 OF 1

UNLESS OTHERWISE SPECIFIED,
DIMENSIONS ARE INCHES.
TOLERANCES ARE:

FRACTIONS: +/- 1/32	DECIMALS: .xx +/- .01 .xxx +/- .005	ANGLES: +/- 1/2
------------------------	---	--------------------

FINISH
POLISHED BRASS

DO NOT SCALE DRAWING

THIS DRAWING IS THE EXCLUSIVE PROPERTY OF REEVE STORE EQUIPMENT CO. WHO HOLDS AND MAINTAINS FULL COPYRIGHT PROTECTION UNDER FEDERAL AND STATE LAW. THIS DRAWING CANNOT BE DUPLICATED, PHOTOCOPIED, DIGITALLY TRANSFERRED, OR REPRODUCED WITHOUT THE EXPRESS WRITTEN CONSENT OF REEVE STORE EQUIPMENT CO. COPYRIGHT 2012, 2011, 2010, 2009, 2008, 2007, 2006, 2005, 2004, 2003, 2002. ALL RIGHTS RESERVED.

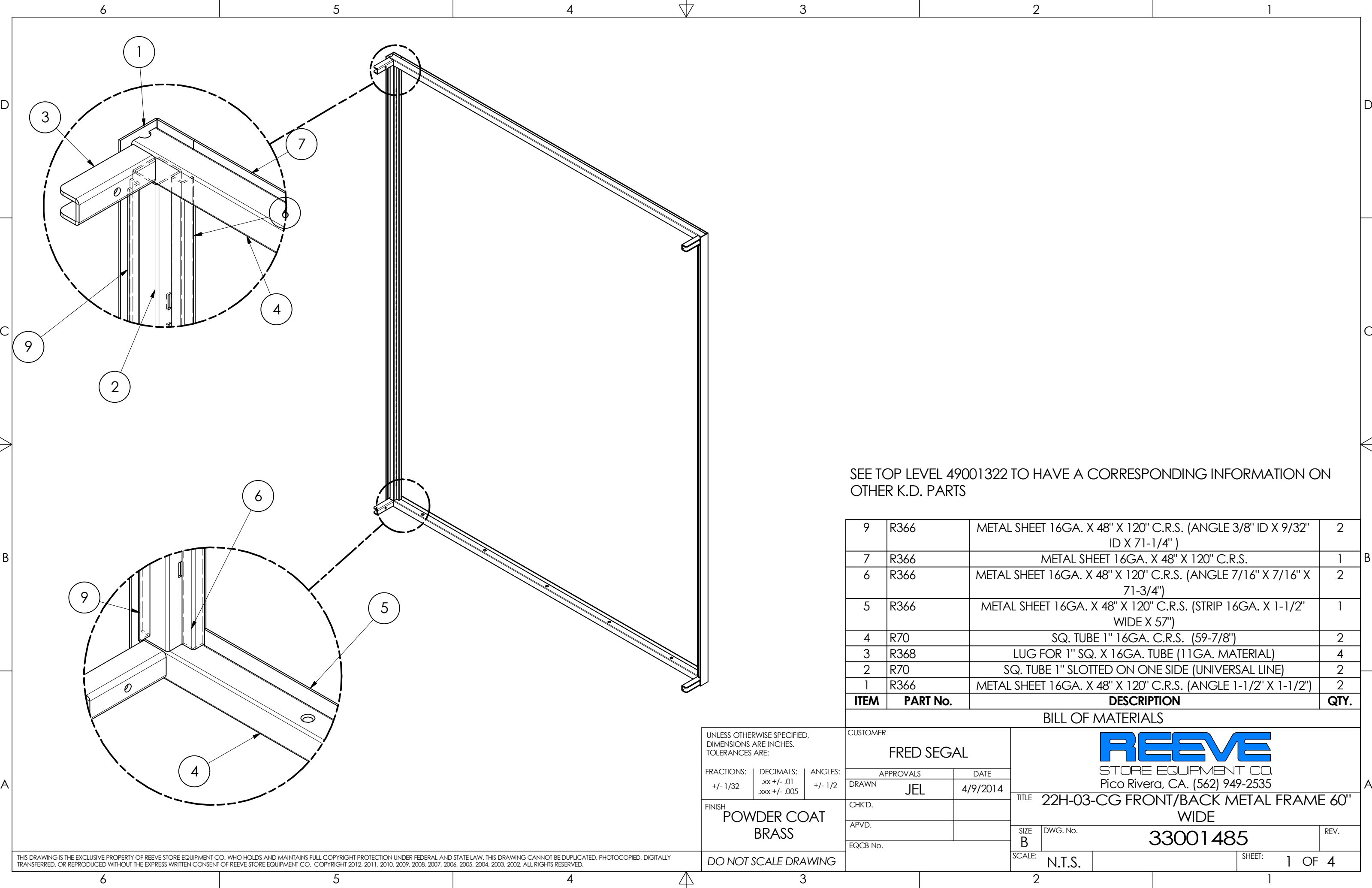

SEE TOP LEVEL 49001322 TO HAVE A CORRESPONDING INFORMATION ON OTHER K.D. PARTS

9	R366	METAL SHEET 16GA. X 48" X 120" C.R.S. (ANGLE 3/8" ID X 9/32" ID X 71-1/4")	2
7	R366	METAL SHEET 16GA. X 48" X 120" C.R.S.	1
6	R366	METAL SHEET 16GA. X 48" X 120" C.R.S. (ANGLE 7/16" X 7/16" X 71-3/4")	2
5	R366	METAL SHEET 16GA. X 48" X 120" C.R.S. (STRIP 16GA. X 1-1/2" WIDE X 57")	1
4	R70	SQ. TUBE 1" 16GA. C.R.S. (59-7/8")	2
3	R368	LUG FOR 1" SQ. X 16GA. TUBE (11GA. MATERIAL)	4
2	R70	SQ. TUBE 1" SLOTTED ON ONE SIDE (UNIVERSAL LINE)	2
1	R366	METAL SHEET 16GA. X 48" X 120" C.R.S. (ANGLE 1-1/2" X 1-1/2")	2
ITEM	PART No.	DESCRIPTION	QTY.

BILL OF MATERIALS

UNLESS OTHERWISE SPECIFIED, DIMENSIONS ARE INCHES. TOLERANCES ARE:		CUSTOMER		 Pico Rivera, CA. (562) 949-2535	
FRACTIONS:	DECIMALS:	ANGLES:	FRED SEGAL		
+/- 1/32	.xx +/- .01 .xxx +/- .005	+/- 1/2	APPROVALS	DATE	TITLE
FINISH			DRAWN	JEL	4/9/2014
POWDER COAT BRASS			CHK'D.		
DO NOT SCALE DRAWING			APVD.		
			EQCB No.		
			DWG. No.		33001485
			SCALE:	N.T.S.	REV.
			SHEET:		1 OF 4

THIS DRAWING IS THE EXCLUSIVE PROPERTY OF REEVE STORE EQUIPMENT CO. WHO HOLDS AND MAINTAINS FULL COPYRIGHT PROTECTION UNDER FEDERAL AND STATE LAW. THIS DRAWING CANNOT BE DUPLICATED, PHOTOCOPIED, DIGITALLY TRANSFERRED, OR REPRODUCED WITHOUT THE EXPRESS WRITTEN CONSENT OF REEVE STORE EQUIPMENT CO. COPYRIGHT 2012, 2011, 2010, 2009, 2008, 2007, 2006, 2005, 2004, 2003, 2002. ALL RIGHTS RESERVED.

6 5 4 3 2 1

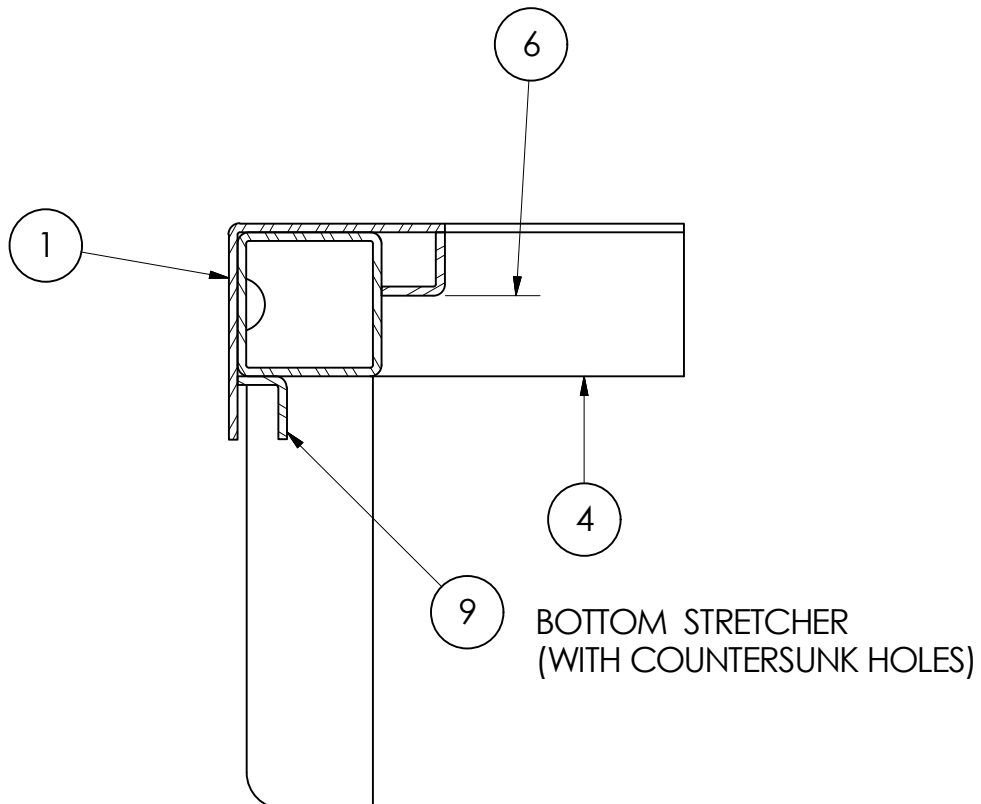
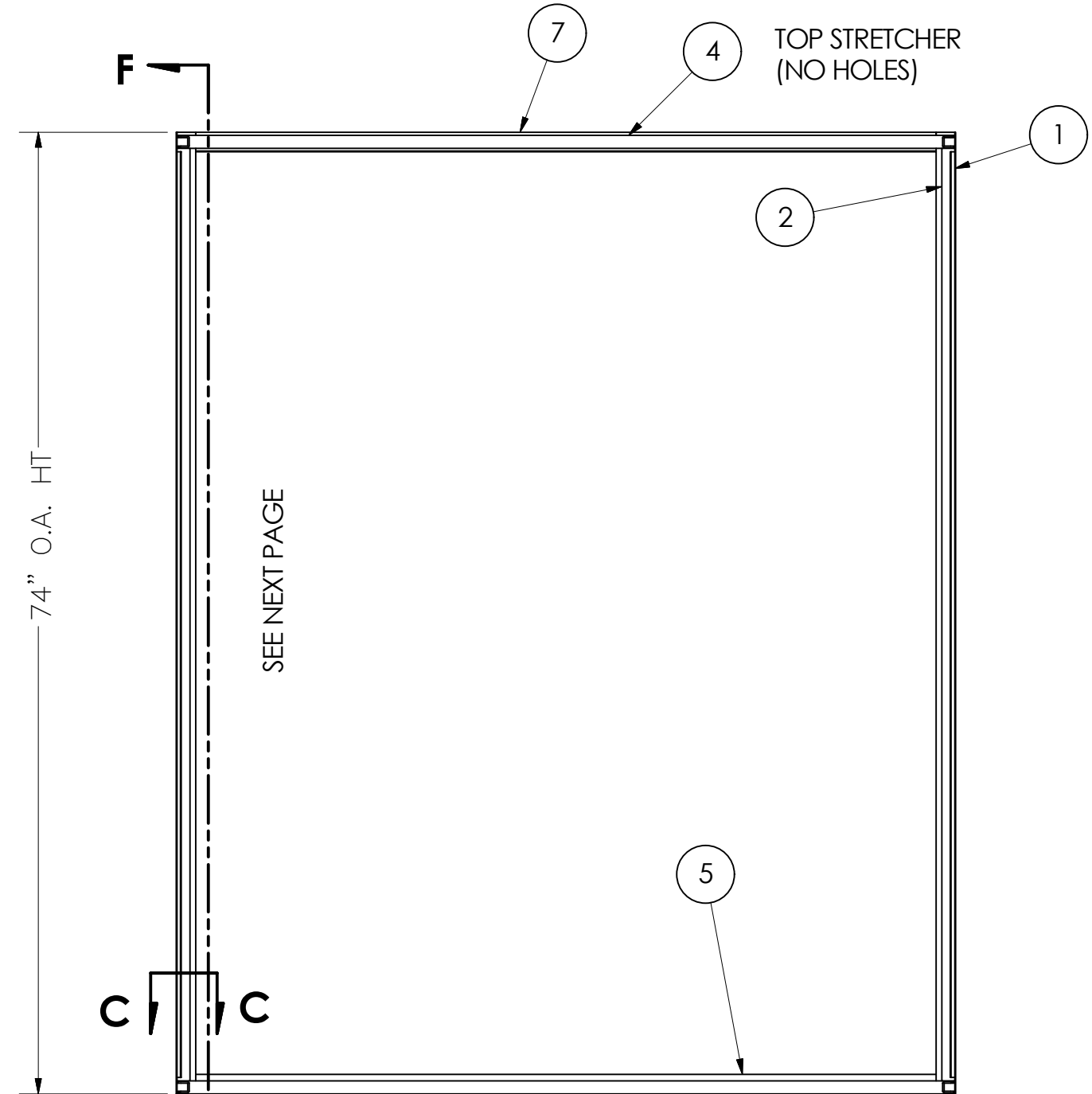
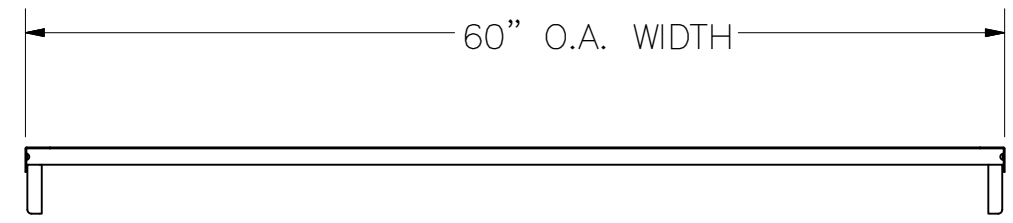

9	R366	METAL SHEET 16GA. X 48" X 120" C.R.S. (ANGLE 3/8" ID X 9/32" ID X 71-1/4")	2
7	R366	METAL SHEET 16GA. X 48" X 120" C.R.S.	1
6	R366	METAL SHEET 16GA. X 48" X 120" C.R.S. (ANGLE 7/16" X 7/16" X 71-3/4")	2
5	R366	METAL SHEET 16GA. X 48" X 120" C.R.S. (STRIP 16GA. X 1-1/2" WIDE X 57")	1
4	R70	SQ. TUBE 1" 16GA. C.R.S. (59-7/8")	2
3	R368	LUG FOR 1" SQ. X 16GA. TUBE (11GA. MATERIAL)	4
2	R70	SQ. TUBE 1" SLOTTED ON ONE SIDE (UNIVERSAL LINE)	2
1	R366	METAL SHEET 16GA. X 48" X 120" C.R.S. (ANGLE 1-1/2" X 1-1/2")	2
ITEM	PART No.	DESCRIPTION	QTY.

BILL OF MATERIALS

UNLESS OTHERWISE SPECIFIED, DIMENSIONS ARE INCHES. TOLERANCES ARE: FRACTIONS: +/- 1/32 DECIMALS: .xx +/- .01 ANGLES: +/- 1/2 .xxx +/- .005 FINISH: POWDER COAT BRASS DO NOT SCALE DRAWING	CUSTOMER: FRED SEGAL		 Pico Rivera, CA. (562) 949-2535	
	APPROVALS: DRAWN JEL	DATE: 4/9/2014		
	CHK'D.	APVD.	SIZE B	DWG. No. 33001485
	EQCB No.	SCALE: N.T.S.	REV.	SHEET: 2 OF 4

THIS DRAWING IS THE EXCLUSIVE PROPERTY OF REEVE STORE EQUIPMENT CO. WHO HOLDS AND MAINTAINS FULL COPYRIGHT PROTECTION UNDER FEDERAL AND STATE LAW. THIS DRAWING CANNOT BE DUPLICATED, PHOTOCOPIED, DIGITALLY TRANSFERRED, OR REPRODUCED WITHOUT THE EXPRESS WRITTEN CONSENT OF REEVE STORE EQUIPMENT CO. COPYRIGHT 2012, 2011, 2010, 2009, 2008, 2007, 2006, 2005, 2004, 2003, 2002. ALL RIGHTS RESERVED.

6 5 4 3 2 1

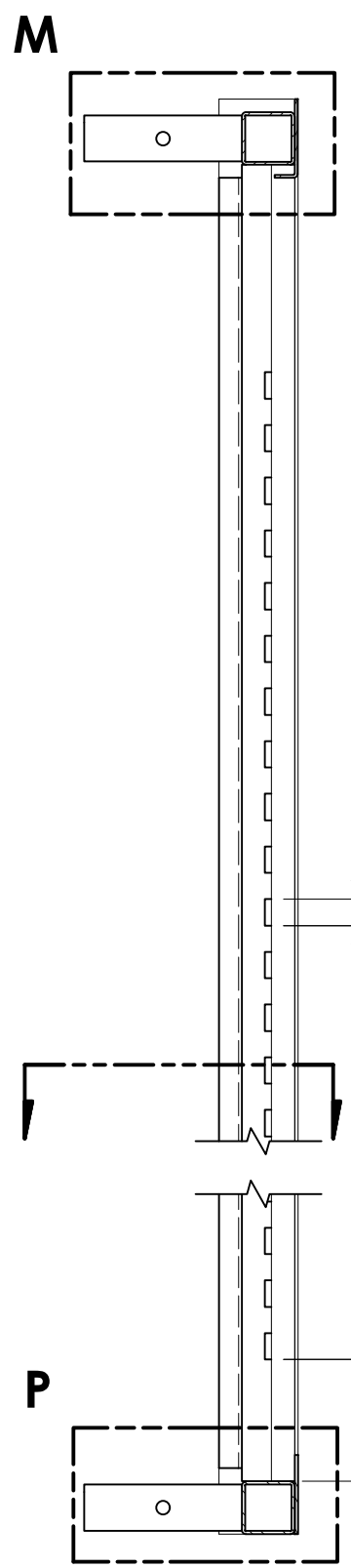

SECTION L-L

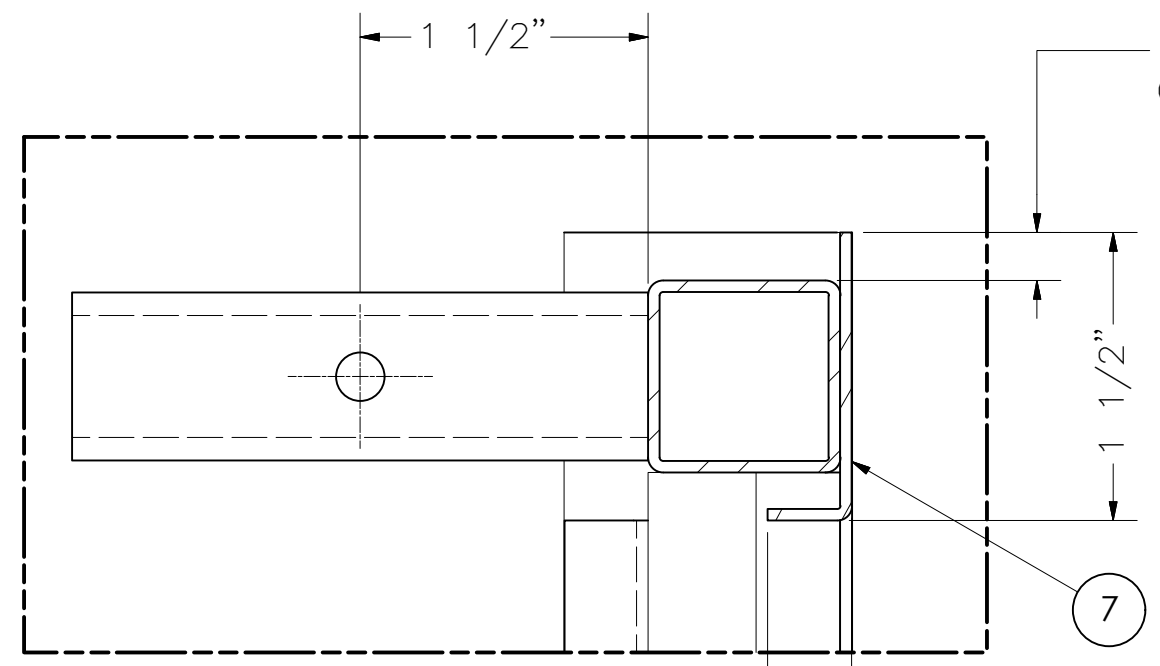

DETAIL M

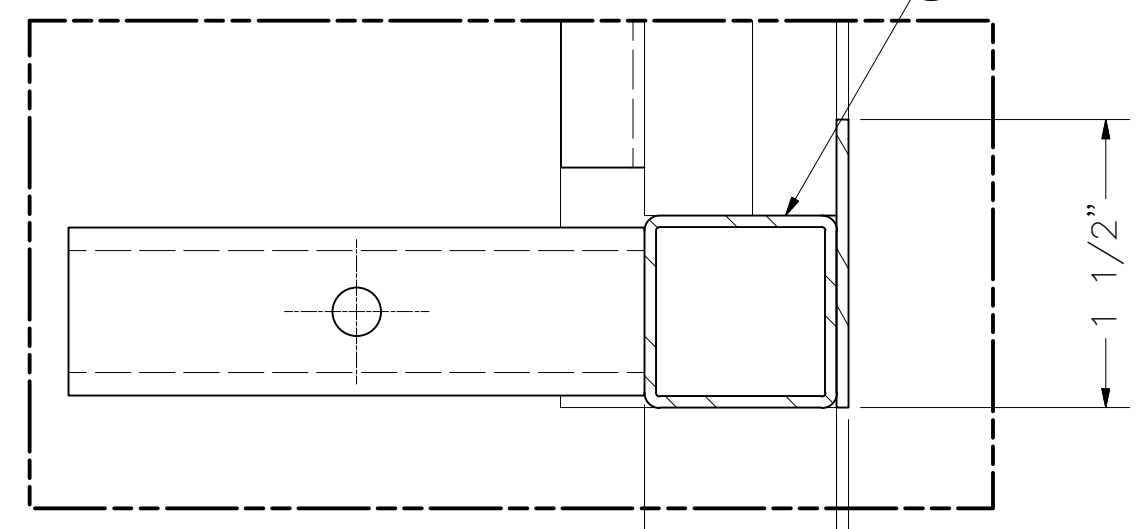

DETAIL P

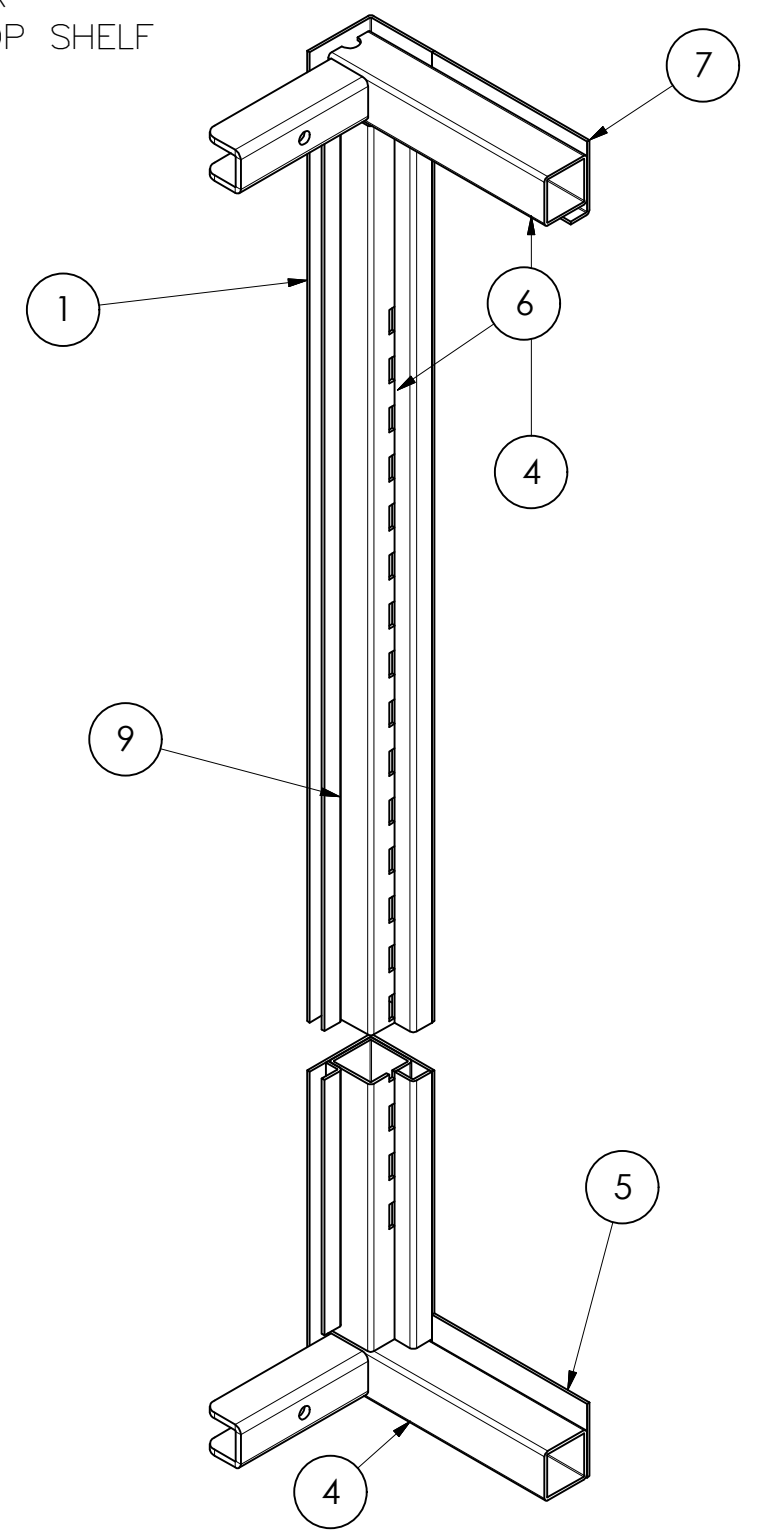

UNLESS OTHERWISE SPECIFIED, DIMENSIONS ARE INCHES. TOLERANCES ARE:			CUSTOMER FRED SEGAL	
FRACTIONS: +/- 1/32	DECIMALS: .xx +/- .01 .xxx +/- .005	ANGLES: +/- 1/2	APPROVALS	DATE
FINISH POWDER COAT BRASS			DRAWN JEL	4/9/2014
DO NOT SCALE DRAWING			CHK'D.	
			APVD.	
			EQCB No.	

REEVE STORE EQUIPMENT CO. Pico Rivera, CA. (562) 949-2535		
TITLE 22H-03-CG FRONT/BACK METAL FRAME 60" WIDE		
SIZE B	DWG. No. 33001485	REV.
SCALE: N.T.S.	SHEET: 3 OF 4	

THIS DRAWING IS THE EXCLUSIVE PROPERTY OF REEVE STORE EQUIPMENT CO. WHO HOLDS AND MAINTAINS FULL COPYRIGHT PROTECTION UNDER FEDERAL AND STATE LAW. THIS DRAWING CANNOT BE DUPLICATED, PHOTOCOPIED, DIGITALLY TRANSFERRED, OR REPRODUCED WITHOUT THE EXPRESS WRITTEN CONSENT OF REEVE STORE EQUIPMENT CO. COPYRIGHT 2012, 2011, 2010, 2009, 2008, 2007, 2006, 2005, 2004, 2003, 2002. ALL RIGHTS RESERVED.

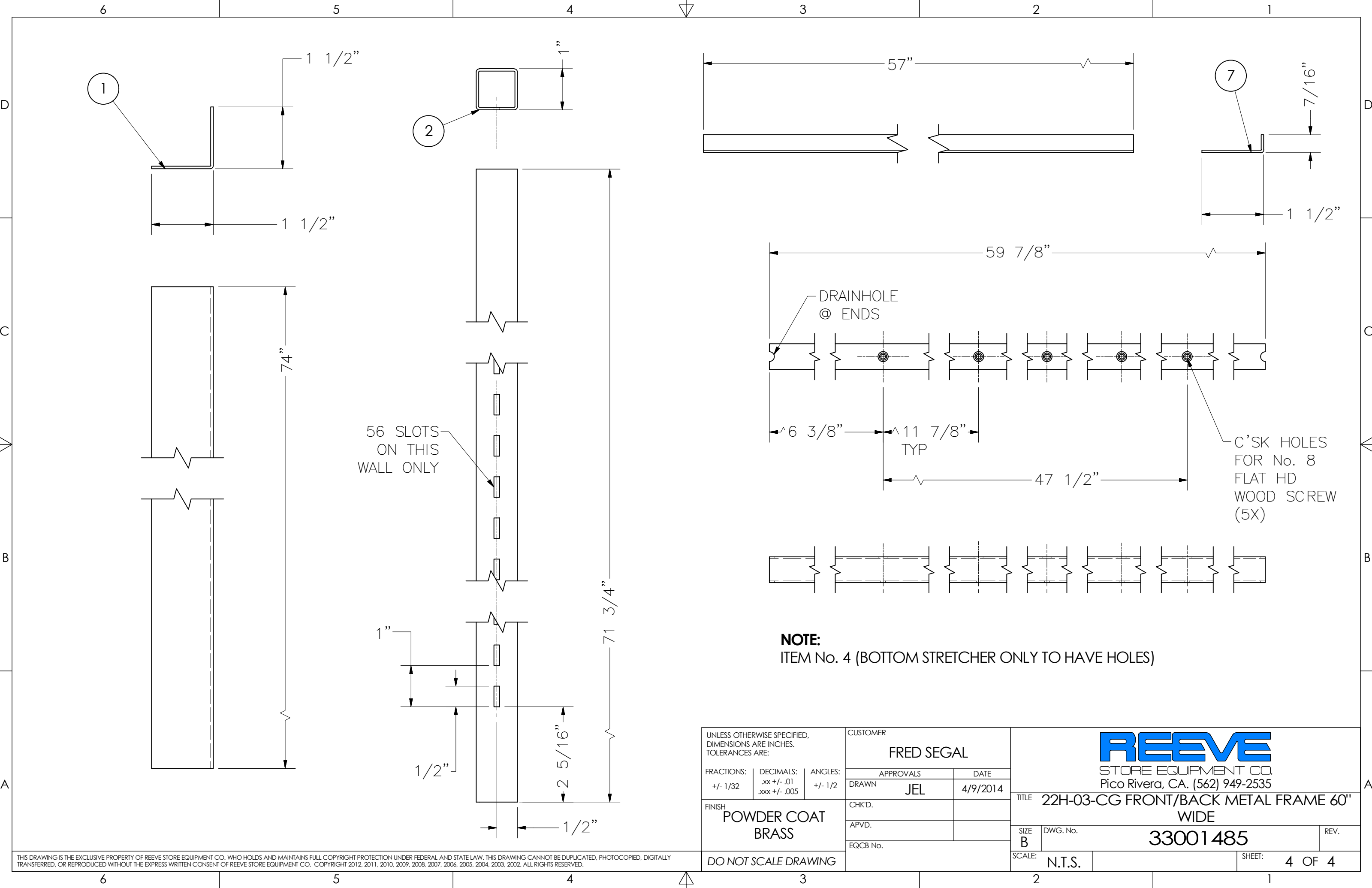

56 SLOTS
ON THIS
WALL ONLY

DRAINHOLE
@ ENDS

C'SK HOLES
FOR No. 8
FLAT HD
WOOD SCREW
(5X)

NOTE:
ITEM No. 4 (BOTTOM STRETCHER ONLY TO HAVE HOLES)

UNLESS OTHERWISE SPECIFIED, DIMENSIONS ARE INCHES. TOLERANCES ARE:	CUSTOMER		 STORE EQUIPMENT CO. Pico Rivera, CA. (562) 949-2535	
	FRED SEGAL			
FRACTIONS: +/- 1/32	DECIMALS: .xx +/- .01 .xxx +/- .005	ANGLES: +/- 1/2	APPROVALS	DATE
FINISH POWDER COAT BRASS			CHK'D.	
DO NOT SCALE DRAWING			APVD.	
			EQCB No.	
			TITLE	22H-03-CG FRONT/BACK METAL FRAME 60" WIDE
			SIZE B	DWG. No. 33001485
			SCALE: N.T.S.	REV. SHEET: 4 OF 4

THIS DRAWING IS THE EXCLUSIVE PROPERTY OF REEVE STORE EQUIPMENT CO. WHO HOLDS AND MAINTAINS FULL COPYRIGHT PROTECTION UNDER FEDERAL AND STATE LAW. THIS DRAWING CANNOT BE DUPLICATED, PHOTOCOPIED, DIGITALLY TRANSFERRED, OR REPRODUCED WITHOUT THE EXPRESS WRITTEN CONSENT OF REEVE STORE EQUIPMENT CO. COPYRIGHT 2012, 2011, 2010, 2009, 2008, 2007, 2006, 2005, 2004, 2003, 2002. ALL RIGHTS RESERVED.

6

5

4

3

2

1

71 5/8"

17 5/8"

NO SHARP EDGES

UNLESS OTHERWISE SPECIFIED, DIMENSIONS ARE INCHES. TOLERANCES ARE:			CUSTOMER		 STORE EQUIPMENT CO. Pico Rivera, CA. (562) 949-2535
FRACTIONS: +/- 1/32	DECIMALS: .xx +/- .01 .xxx +/- .005	ANGLES: +/- 1/2	APPROVALS	DATE	
FINISH CLEAR TEMPERED			DRAWN JEL	4/9/2014	TITLE 22H-02-CG GLASS PANEL 1/4" X 17-5/8" X 71-5/8" CLEAR TEMPERED
DO NOT SCALE DRAWING			CHK'D.		SIZE B
			APVD.		DWG. No. 62000909
			EQCB No.		REV.
					SCALE: N.T.S.
					SHEET: 1 OF 1

THIS DRAWING IS THE EXCLUSIVE PROPERTY OF REEVE STORE EQUIPMENT CO. WHO HOLDS AND MAINTAINS FULL COPYRIGHT PROTECTION UNDER FEDERAL AND STATE LAW. THIS DRAWING CANNOT BE DUPLICATED, PHOTOCOPIED, DIGITALLY TRANSFERRED, OR REPRODUCED WITHOUT THE EXPRESS WRITTEN CONSENT OF REEVE STORE EQUIPMENT CO. COPYRIGHT 2012, 2011, 2010, 2009, 2008, 2007, 2006, 2005, 2004, 2003, 2002. ALL RIGHTS RESERVED.

6 5 4 3 2 1

D
C
B
A

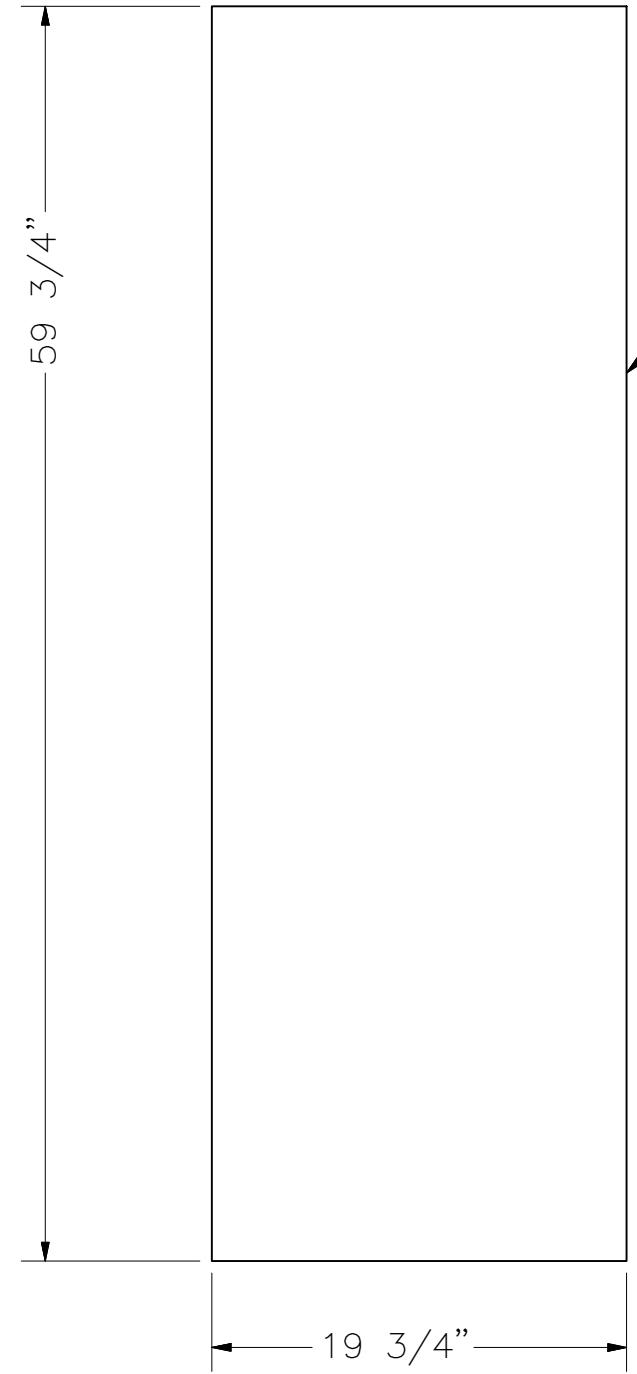

POLISHED ALL SIDES

MATERIAL:
1/4" THK. CLEAR TEMPERED GLASS WITH POLISHED EDGES

UNLESS OTHERWISE SPECIFIED, DIMENSIONS ARE INCHES. TOLERANCES ARE:			CUSTOMER	
FRACTIONS: +/- 1/32	DECIMALS: .xx +/- .01 .xxx +/- .005	ANGLES: +/- 1/2	APPROVALS	DATE
FINISH CLEAR TEMPERED			DRAWN JEL	4/9/2014
DO NOT SCALE DRAWING			CHK'D.	
			APVD.	
			EQCB No.	



STORE EQUIPMENT CO.
Pico Rivera, CA. (562) 949-2535

TITLE 22H-02-CG GLASS TOP SHELF 1/4" X 19-3/4" X 59-3/4" CLEAR TEMPERED		
SIZE B	DWG. No. 62000982	REV.
SCALE: N.T.S.	SHEET: 1 OF 1	

THIS DRAWING IS THE EXCLUSIVE PROPERTY OF REEVE STORE EQUIPMENT CO. WHO HOLDS AND MAINTAINS FULL COPYRIGHT PROTECTION UNDER FEDERAL AND STATE LAW. THIS DRAWING CANNOT BE DUPLICATED, PHOTOCOPIED, DIGITALLY TRANSFERRED, OR REPRODUCED WITHOUT THE EXPRESS WRITTEN CONSENT OF REEVE STORE EQUIPMENT CO. COPYRIGHT 2012, 2011, 2010, 2009, 2008, 2007, 2006, 2005, 2004, 2003, 2002. ALL RIGHTS RESERVED.

6 5 4 3 2 1

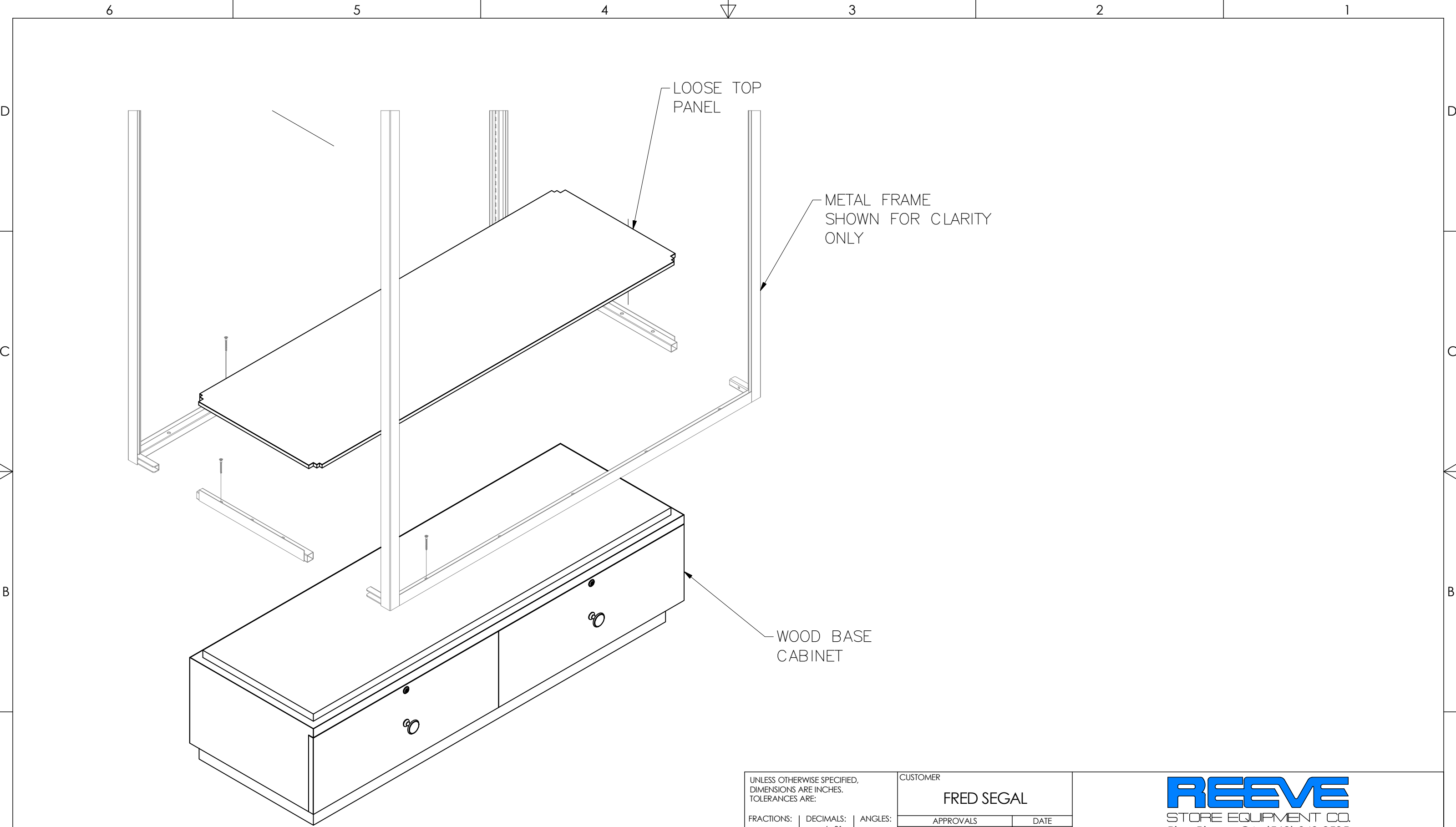

UNLESS OTHERWISE SPECIFIED, DIMENSIONS ARE INCHES. TOLERANCES ARE:		
FRACTIONS: +/- 1/32	DECIMALS: .xx +/- .01 .xxx +/- .005	ANGLES: +/- 1/2
FINISH SEE ABOVE		
DO NOT SCALE DRAWING		

CUSTOMER FRED SEGAL	
APPROVALS	DATE
DRAWN JEL	4/9/2014
CHK'D.	
APVD.	
EQCB No.	

 STORE EQUIPMENT CO. Pico Rivera, CA. (562) 949-2535		
TITLE 22H-02-CG WOOD BASE CABINET 60" X 20" 15" HIGH WITH DRAWERS		
SIZE B	DWG. No. 62000983	REV.
SCALE: N.T.S.	SHEET: 1 OF 5	

THIS DRAWING IS THE EXCLUSIVE PROPERTY OF REEVE STORE EQUIPMENT CO. WHO HOLDS AND MAINTAINS FULL COPYRIGHT PROTECTION UNDER FEDERAL AND STATE LAW. THIS DRAWING CANNOT BE DUPLICATED, PHOTOCOPIED, DIGITALLY TRANSFERRED, OR REPRODUCED WITHOUT THE EXPRESS WRITTEN CONSENT OF REEVE STORE EQUIPMENT CO. COPYRIGHT 2012, 2011, 2010, 2009, 2008, 2007, 2006, 2005, 2004, 2003, 2002. ALL RIGHTS RESERVED.

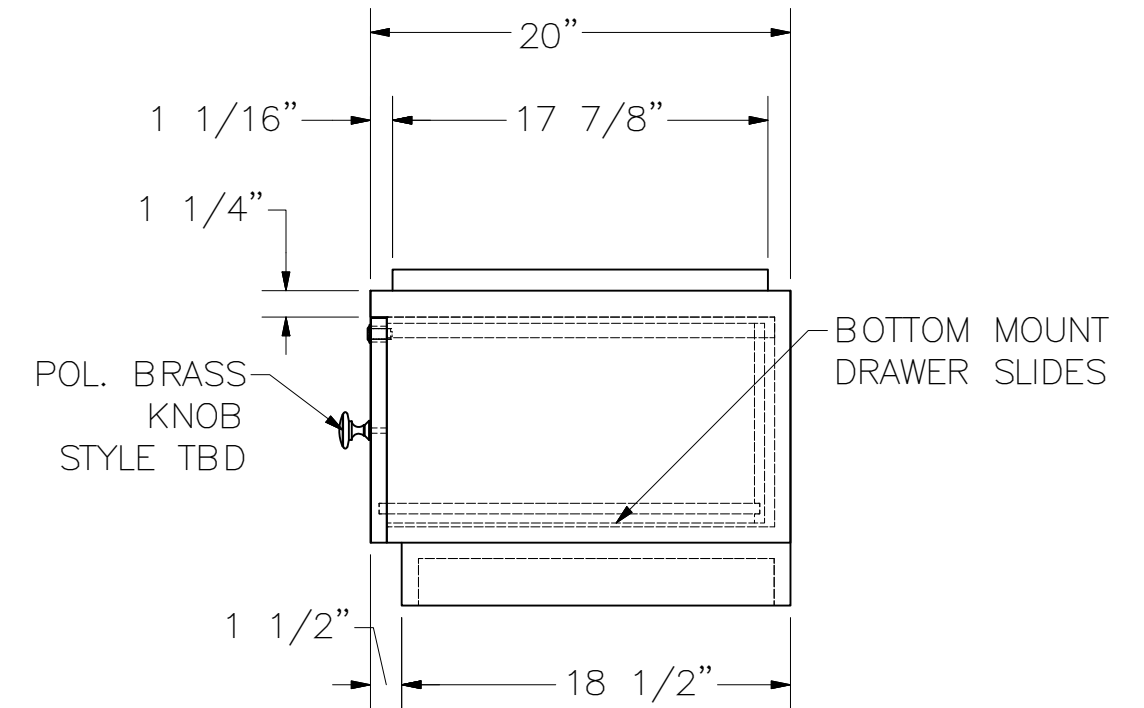
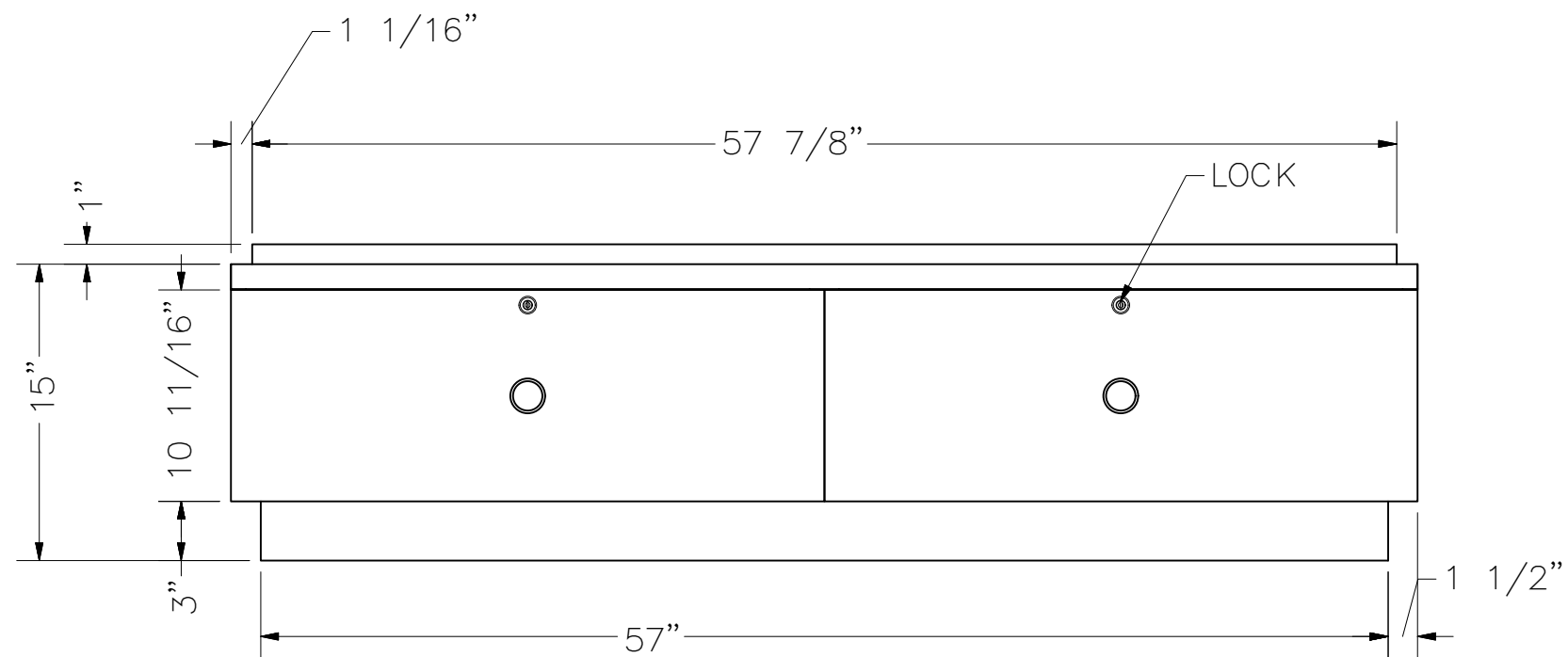
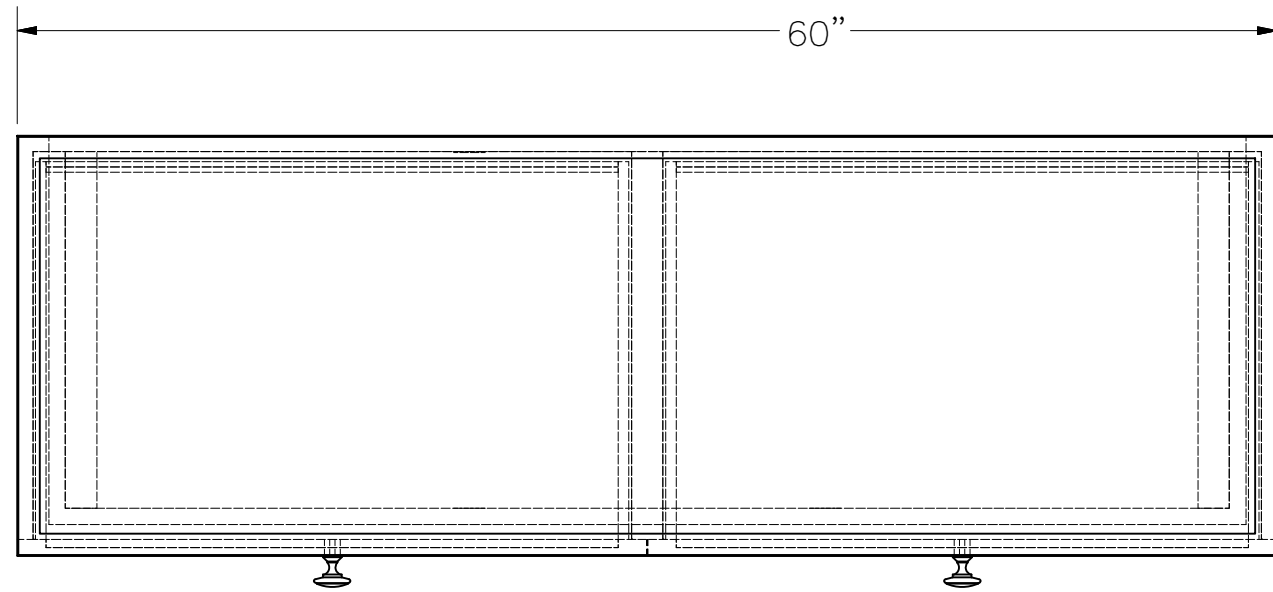

UNLESS OTHERWISE SPECIFIED, DIMENSIONS ARE INCHES. TOLERANCES ARE:			CUSTOMER FRED SEGAL	
FRACTIONS: +/- 1/32	DECIMALS: .xx +/- .01 .xxx +/- .005	ANGLES: +/- 1/2	APPROVALS	DATE
FINISH SEE ABOVE			DRAWN JEL	4/9/2014
DO NOT SCALE DRAWING			CHK'D.	
			APVD.	
			EQCB No.	

REEVE
STORE EQUIPMENT CO.
Pico Rivera, CA. (562) 949-2535

TITLE: **22H-02-CG WOOD BASE CABINET 60" X 20" 15" HIGH WITH DRAWERS**

SIZE: **B** DWG. No. **62000983** REV.

SCALE: **N.T.S.** SHEET: **2 OF 5**

THIS DRAWING IS THE EXCLUSIVE PROPERTY OF REEVE STORE EQUIPMENT CO. WHO HOLDS AND MAINTAINS FULL COPYRIGHT PROTECTION UNDER FEDERAL AND STATE LAW. THIS DRAWING CANNOT BE DUPLICATED, PHOTOCOPIED, DIGITALLY TRANSFERRED, OR REPRODUCED WITHOUT THE EXPRESS WRITTEN CONSENT OF REEVE STORE EQUIPMENT CO. COPYRIGHT 2012, 2011, 2010, 2009, 2008, 2007, 2006, 2005, 2004, 2003, 2002. ALL RIGHTS RESERVED.

6 5 4 3 2 1

1 1/16"
FOR 1" SQ.
METAL FRAME
ALL AROUND

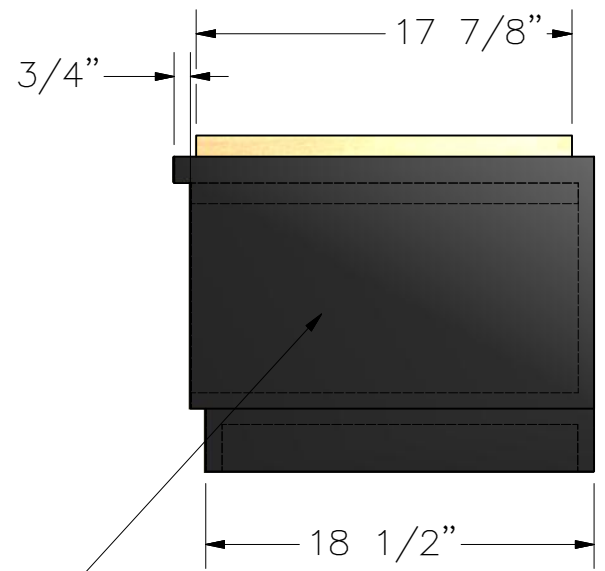
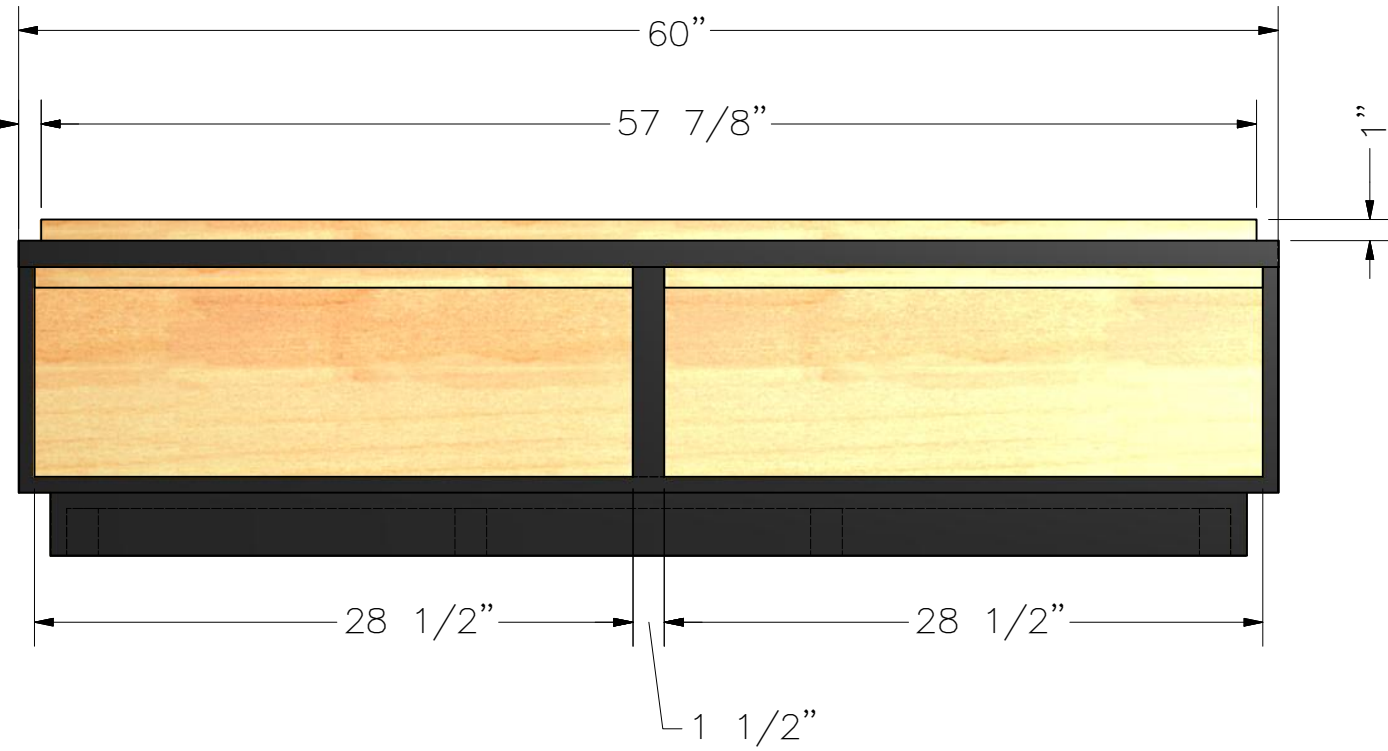

BLACK LACQUER
FINISH TO MATCH
PANTONE 4C

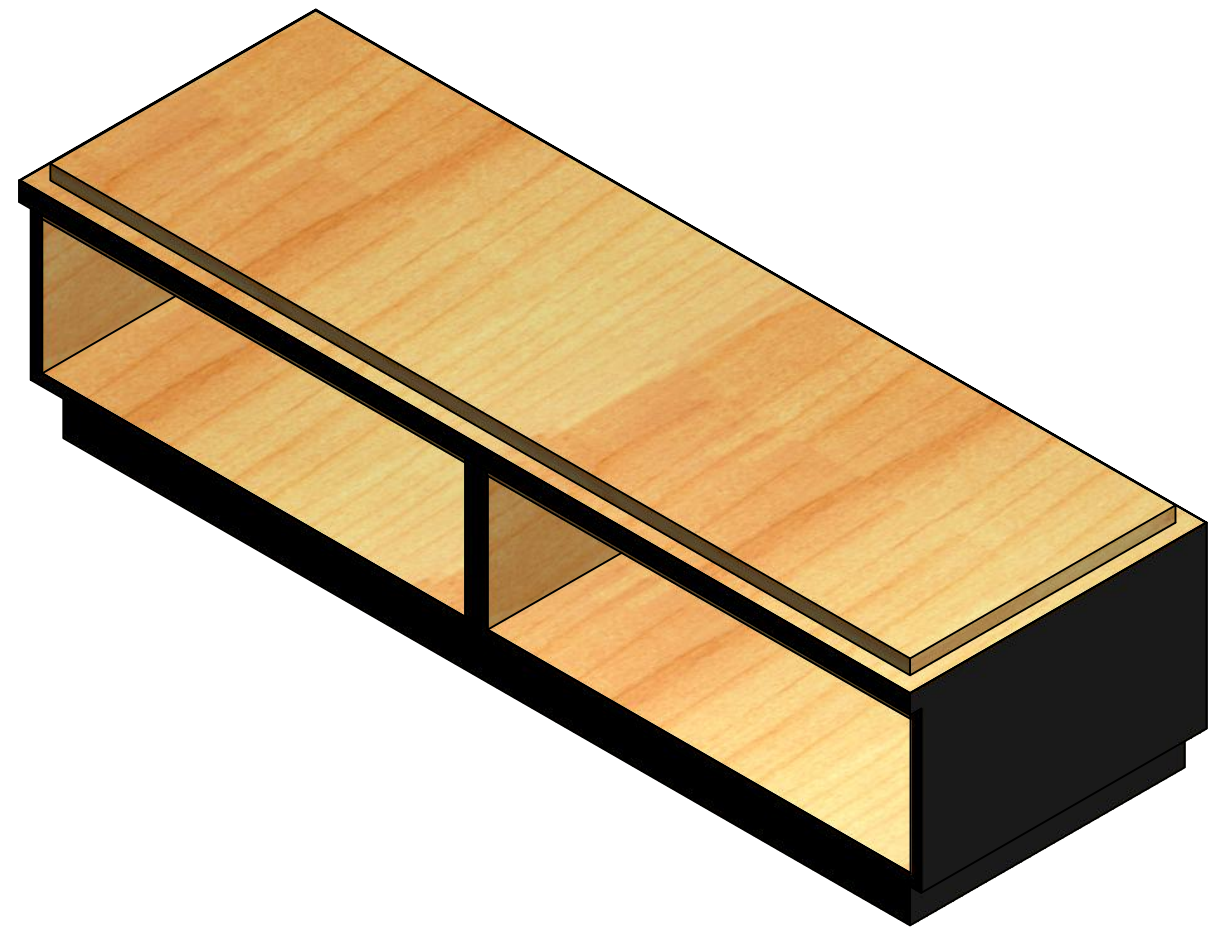

MATERIAL:
3/4" THK PLY AND MDF

<small>UNLESS OTHERWISE SPECIFIED, DIMENSIONS ARE INCHES. TOLERANCES ARE:</small> <small>FRACTIONS: DECIMALS: ANGLES:</small> <small>+/- 1/32 .xx +/- .01 +/- 1/2</small> <small> .xxx +/- .005</small> <small>FINISH</small> <p style="text-align: center;">SEE ABOVE</p>	<small>CUSTOMER</small> <p style="text-align: center;">FRED SEGAL</p>		 <small>STORE EQUIPMENT CO. Pico Rivera, CA. (562) 949-2535</small>	
	<small>APPROVALS</small> <small>DRAWN</small> JEL	<small>DATE</small> 4/9/2014		
	<small>CHK'D.</small> <small>APVD.</small> <small>EQCB No.</small>	<small>SCALE</small> N.T.S.	<small>DWG. No.</small> <p style="text-align: center;">62000983</p>	<small>REV.</small>
	<p style="text-align: center;"><i>DO NOT SCALE DRAWING</i></p>		<small>SHEET:</small> 3 OF 5	

THIS DRAWING IS THE EXCLUSIVE PROPERTY OF REEVE STORE EQUIPMENT CO. WHO HOLDS AND MAINTAINS FULL COPYRIGHT PROTECTION UNDER FEDERAL AND STATE LAW. THIS DRAWING CANNOT BE DUPLICATED, PHOTOCOPIED, DIGITALLY TRANSFERRED, OR REPRODUCED WITHOUT THE EXPRESS WRITTEN CONSENT OF REEVE STORE EQUIPMENT CO. COPYRIGHT 2012, 2011, 2010, 2009, 2008, 2007, 2006, 2005, 2004, 2003, 2002. ALL RIGHTS RESERVED.

6 5 4 3 2 1

POLISHED BRASS LOCK

INSIDE OF DRAWER TO BE FINISHED WITH CLEAR LACQUER

POLISHED BRASS KNOB
STYLE TBD

BLACK LACQUER FINISH TO MATCH PANTONE 4C ON THE FACE AND EXPOSED EDGES OF DRAWER DOOR.

BOTTOM MOUNT DRAWER SLIDES

1/2"

3/4"

MATERIAL:
3/4" AND 1/2" THK. TYPE B PLYWOOD

UNLESS OTHERWISE SPECIFIED, DIMENSIONS ARE INCHES. TOLERANCES ARE: FRACTIONS: +/- 1/32 DECIMALS: .xx +/- .01 .xxx +/- .005 ANGLES: +/- 1/2	CUSTOMER FRED SEGAL		 STORE EQUIPMENT CO. Pico Rivera, CA. (562) 949-2535
	APPROVALS DRAWN JEL	DATE 4/9/2014	
FINISH SEE ABOVE	CHK'D.		SIZE B
	APVD.		DWG. No. 62000983
DO NOT SCALE DRAWING	EQCB No.		SCALE: N.T.S.
			SHEET: 4 OF 5

THIS DRAWING IS THE EXCLUSIVE PROPERTY OF REEVE STORE EQUIPMENT CO. WHO HOLDS AND MAINTAINS FULL COPYRIGHT PROTECTION UNDER FEDERAL AND STATE LAW. THIS DRAWING CANNOT BE DUPLICATED, PHOTOCOPIED, DIGITALLY TRANSFERRED, OR REPRODUCED WITHOUT THE EXPRESS WRITTEN CONSENT OF REEVE STORE EQUIPMENT CO. COPYRIGHT 2012, 2011, 2010, 2009, 2008, 2007, 2006, 2005, 2004, 2003, 2002. ALL RIGHTS RESERVED.

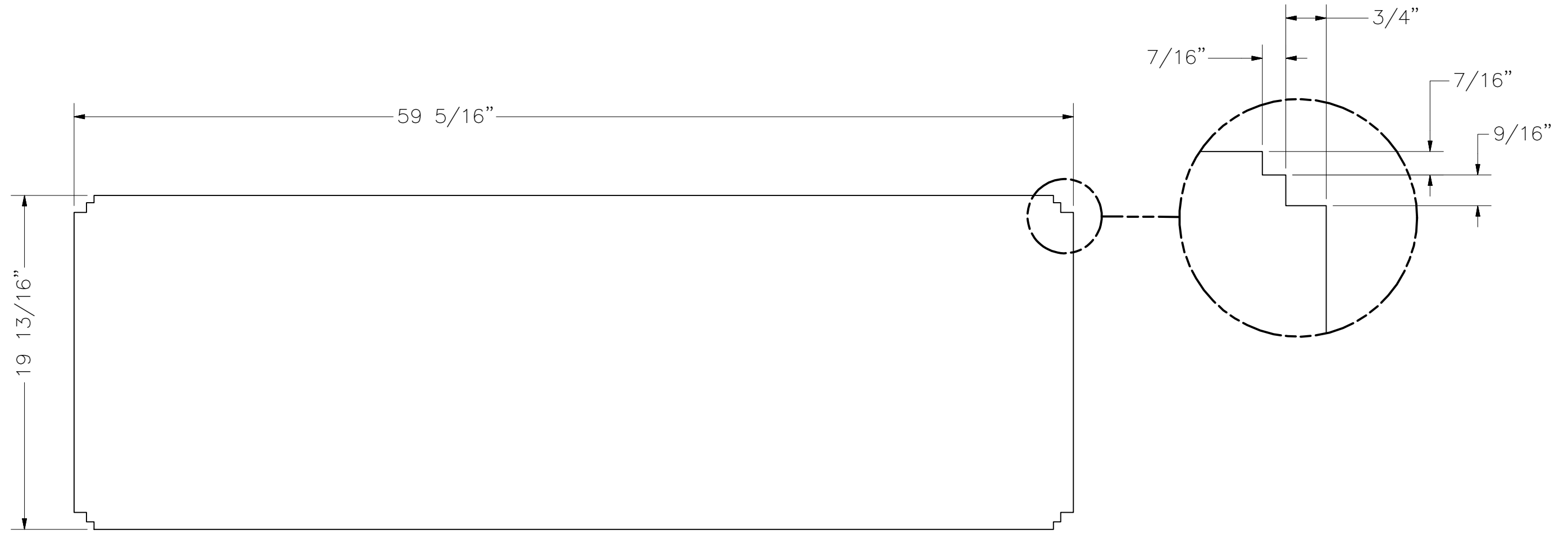

BLACK LACQUER FINISH
TO MATCH PANTONE 4C
ON TOP, SHORT AND LONG
EDGES

LOOSE TOP PANEL

MATERIAL:
1/2" THK. TYPE B PLYWOOD

UNLESS OTHERWISE SPECIFIED, DIMENSIONS ARE INCHES. TOLERANCES ARE:			CUSTOMER FRED SEGAL		 STORE EQUIPMENT CO. Pico Rivera, CA. (562) 949-2535
FRACTIONS: +/- 1/32	DECIMALS: .xx +/- .01 .xxx +/- .005	ANGLES: +/- 1/2	APPROVALS	DATE	
FINISH SEE ABOVE			DRAWN JEL	4/9/2014	
DO NOT SCALE DRAWING			CHK'D.		TITLE 22H-03-CG WOOD BASE CABINET 60" X 20" 15" HIGH WITH DRAWERS
			APVD.		SIZE B
			EQCB No.		DWG. No. 62000983
					SCALE: N.T.S.
					REV.
					SHEET: 5 OF 5

THIS DRAWING IS THE EXCLUSIVE PROPERTY OF REEVE STORE EQUIPMENT CO. WHO HOLDS AND MAINTAINS FULL COPYRIGHT PROTECTION UNDER FEDERAL AND STATE LAW. THIS DRAWING CANNOT BE DUPLICATED, PHOTOCOPIED, DIGITALLY TRANSFERRED, OR REPRODUCED WITHOUT THE EXPRESS WRITTEN CONSENT OF REEVE STORE EQUIPMENT CO. COPYRIGHT 2012, 2011, 2010, 2009, 2008, 2007, 2006, 2005, 2004, 2003, 2002. ALL RIGHTS RESERVED.

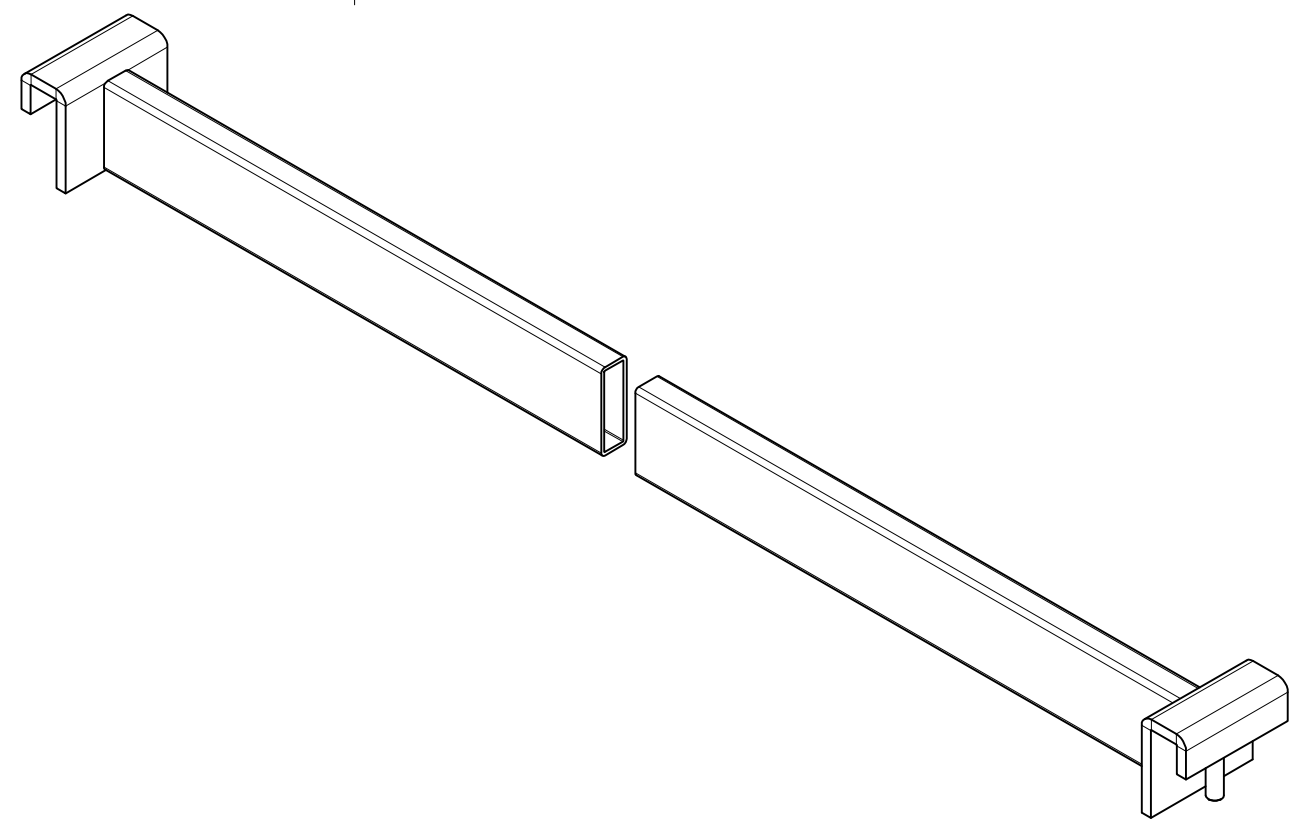
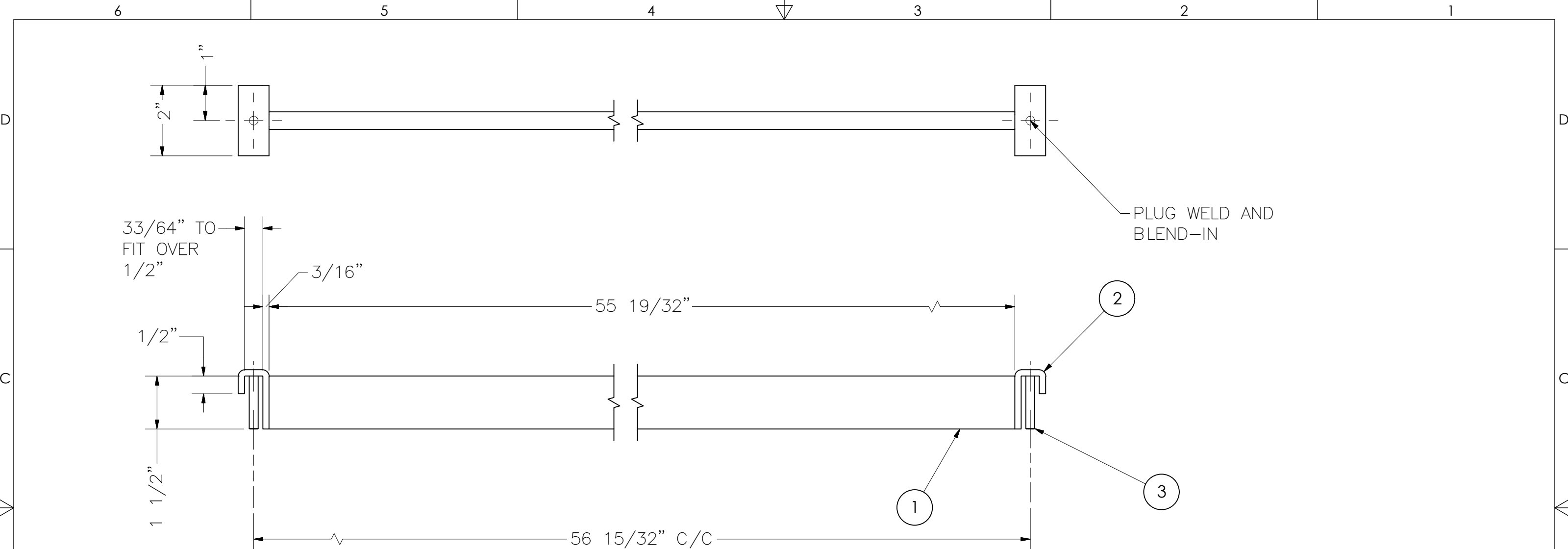

NOTE:
USED ON DWG. No. 40000554 AS AN ASSEMBLY HANGBAR UNIT FOR 49001322

ITEM	PART No.	DESCRIPTION	QTY.
3	R228	3 GA. (.2437) B.B.W. 1008 PACKED ON STEMS	2
2	C725-KM-UN N-MOD	SADDLE FOR 1/2" X 1-1/2" TUBE (MOD)	2
1	R44	RECT. TUBE 1/2" X 1-1/2" 16GA. C.R.S.	1

BILL OF MATERIALS

UNLESS OTHERWISE SPECIFIED, DIMENSIONS ARE INCHES. TOLERANCES ARE:		CUSTOMER FRED SEGAL		 Pico Rivera, CA. (562) 949-2535	
FRACTIONS: +/- 1/32	DECIMALS: .xx +/- .01 .xxx +/- .005	ANGLES: +/- 1/2	APPROVALS		
FINISH POWDER COAT BRASS			DRAWN JEL	5/22/2014	TITLE 22H-02-CG OPEN CASE HANGBAR 56"
DO NOT SCALE DRAWING			CHK'D.		SIZE B
			APVD.		DWG. No. 40000556
			EQCB No.		SCALE: N.T.S.
					REV. 1 OF 1
					SHEET: 1 OF 1

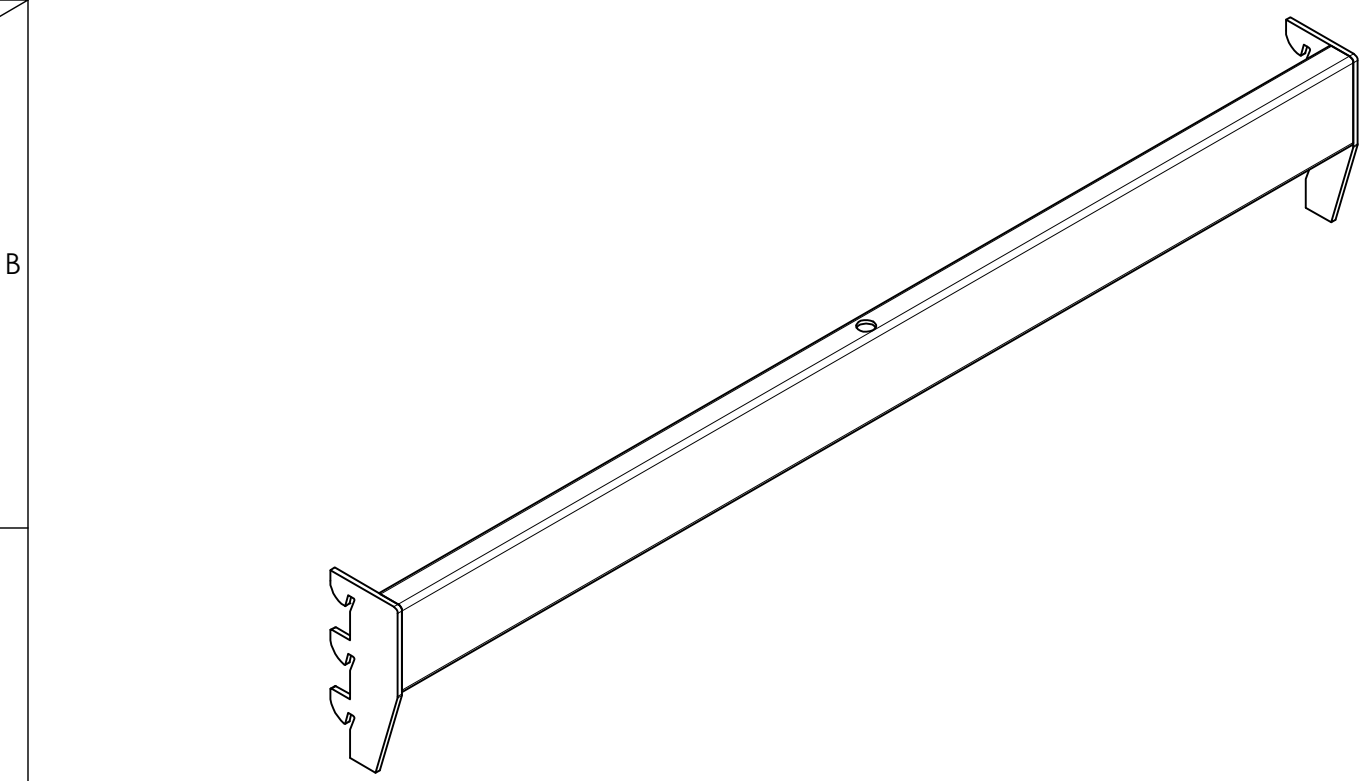
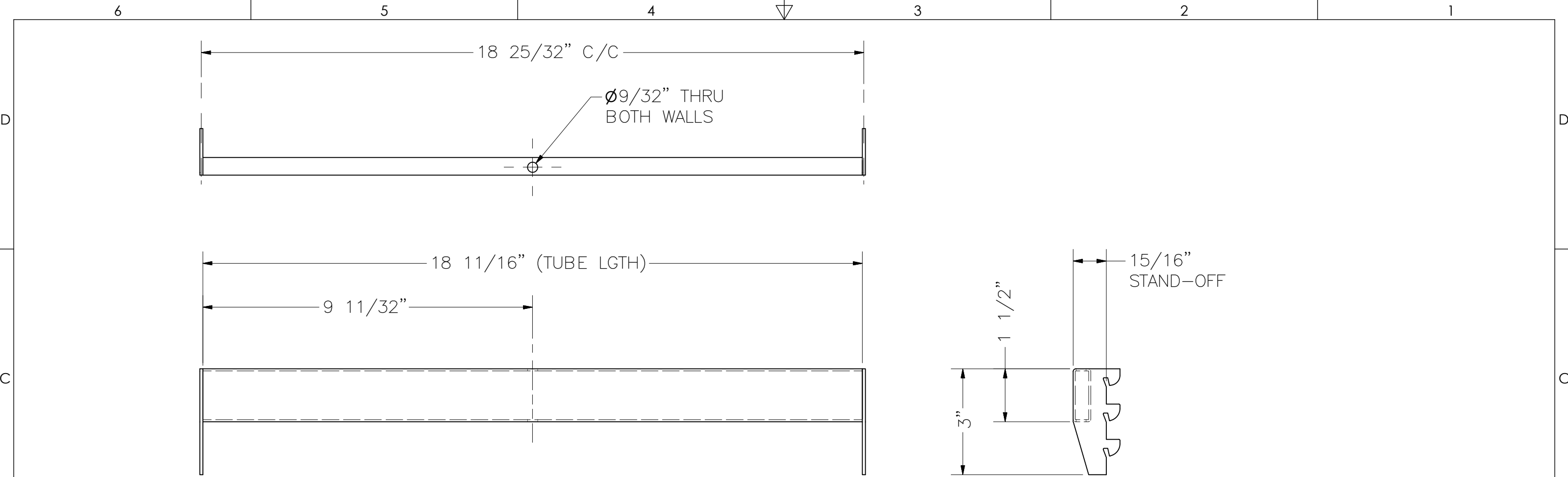

NOTE:
USED ON BOTH DWG. No. 49001292 AND 49001322

2	C680-4 STUB	UNIVERSAL LINE C680 STUB BRACKET (MODIFIED)	2
1	R444	RECT. TUBE 1/2" X 1-1/2" 16GA. C.R.S.	1
ITEM	PART No.	DESCRIPTION	QTY.

BILL OF MATERIALS

UNLESS OTHERWISE SPECIFIED, DIMENSIONS ARE INCHES. TOLERANCES ARE:		CUSTOMER FRED SEGAL		 Pico Rivera, CA. (562) 949-2535	
FRACTIONS: +/- 1/32	DECIMALS: .xx +/- .01 .xxx +/- .005	ANGLES: +/- 1/2	APPROVALS		
FINISH POLISHED BRASS			DRAWN JEL	5/22/2014	TITLE OPEN CASE SIDE HANGBAR 18-7/8" OC.
DO NOT SCALE DRAWING			CHK'D.		SIZE B
			APVD.		DWG. No. 40000554
			EQCB No.		SCALE: N.T.S.
				SHEET:	1 OF 1

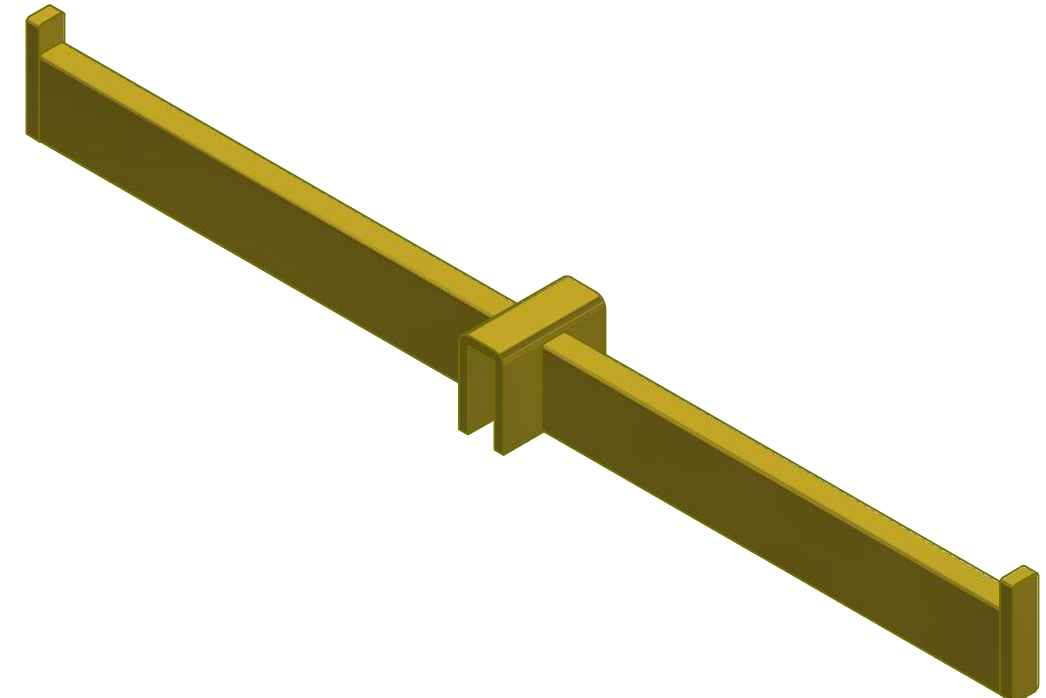
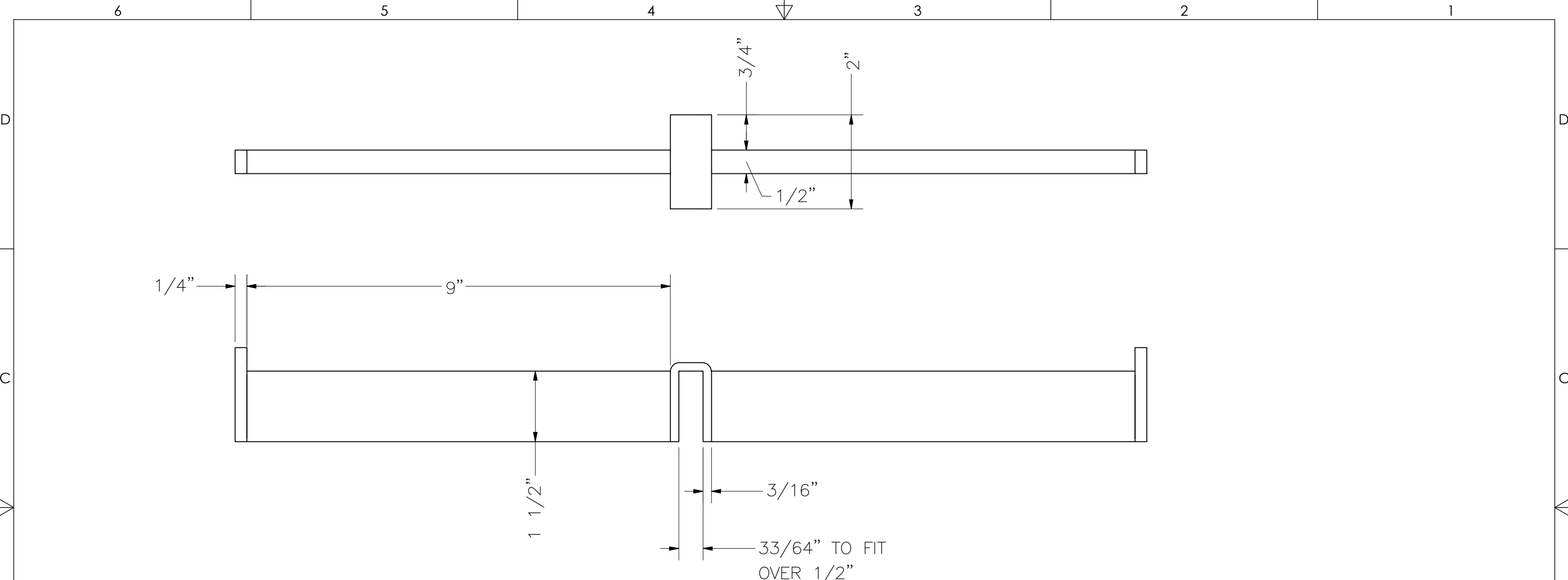

NOTE:
USED ON BOTH DWG. No. 49001292 AND 49001322

ITEM	PART No.	DESCRIPTION	QTY.
3	C227-2-CAP	END CAP 1/4" X 1/2" X 2"	2
2	C725-KM-UNP	SADDLE FOR 1/2" X 1-1/2" TUBE	1
1	R444	RECT. TUBE 1/2" X 1-1/2" 16GA. C.R.S.	2

BILL OF MATERIALS

UNLESS OTHERWISE SPECIFIED,
DIMENSIONS ARE INCHES.
TOLERANCES ARE:

FRACTIONS: +/- 1/32	DECIMALS: .xx +/- .01 .xxx +/- .005	ANGLES: +/- 1/2
------------------------	---	--------------------

FINISH
POLISHED BRASS

DO NOT SCALE DRAWING

CUSTOMER FRED SEGAL	
APPROVALS	DATE
DRAWN JEL	5/22/2014
CHK'D.	
APVD.	
EQCB No.	

 Pico Rivera, CA. (562) 949-2535		TITLE OPEN CASE DOUBLE FACEOUT 9"	
		SIZE B	DWG. No. 20000182
SCALE: N.T.S.		SHEET: 1 OF 1	

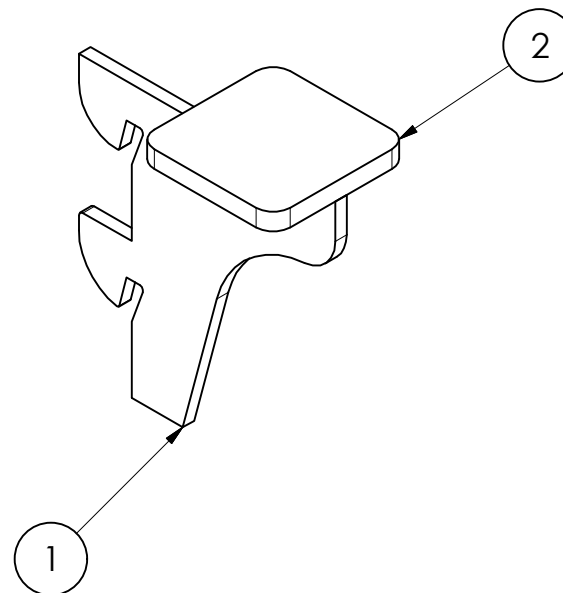
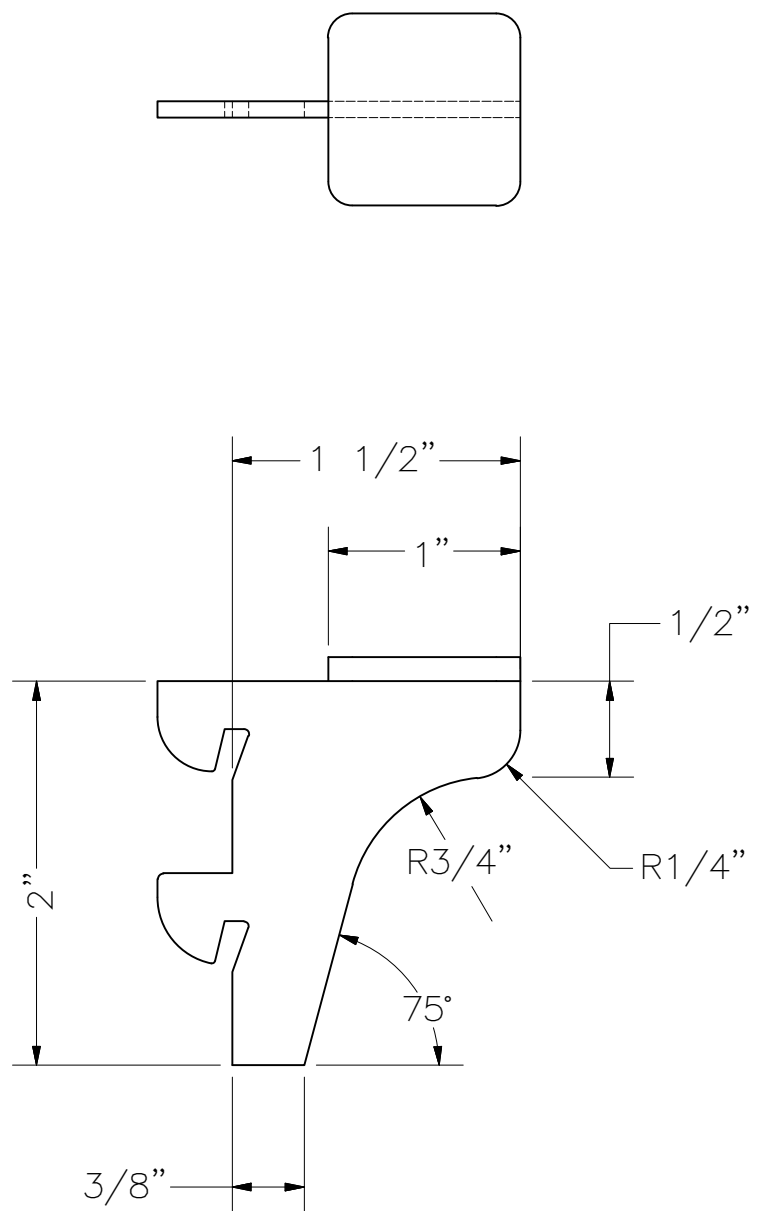

2	R343	FLAT BAR 1/8" X 1" HRPO	1
1	C680-4 STUB	UNIVERSAL LINE C680 STUB BRACKET (MODIFIED)	1
ITEM	PART No.	DESCRIPTION	QTY.

BILL OF MATERIALS

UNLESS OTHERWISE SPECIFIED,
DIMENSIONS ARE INCHES.
TOLERANCES ARE:

FRACTIONS: +/- 1/32	DECIMALS: .xx +/- .01 .xxx +/- .005	ANGLES: +/- 1/2
------------------------	---	--------------------

FINISH
POLISHED BRASS

DO NOT SCALE DRAWING

CUSTOMER FRED SEGAL	
APPROVALS	DATE
DRAWN JEL	4/10/2014
CHK'D.	
APVD.	
EQCB No.	

 Pico Rivera, CA. (562) 949-2535		TITLE SHELF SUPPORT BRACKET-PIN
		SIZE B DWG. No. 39000261 REV.

SCALE: N.T.S.	SHEET: 1 OF 1
----------------------	----------------------

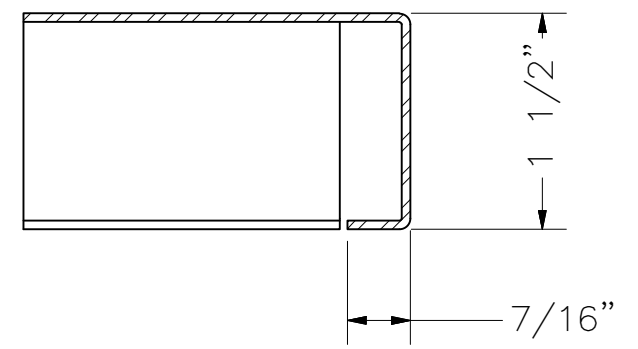
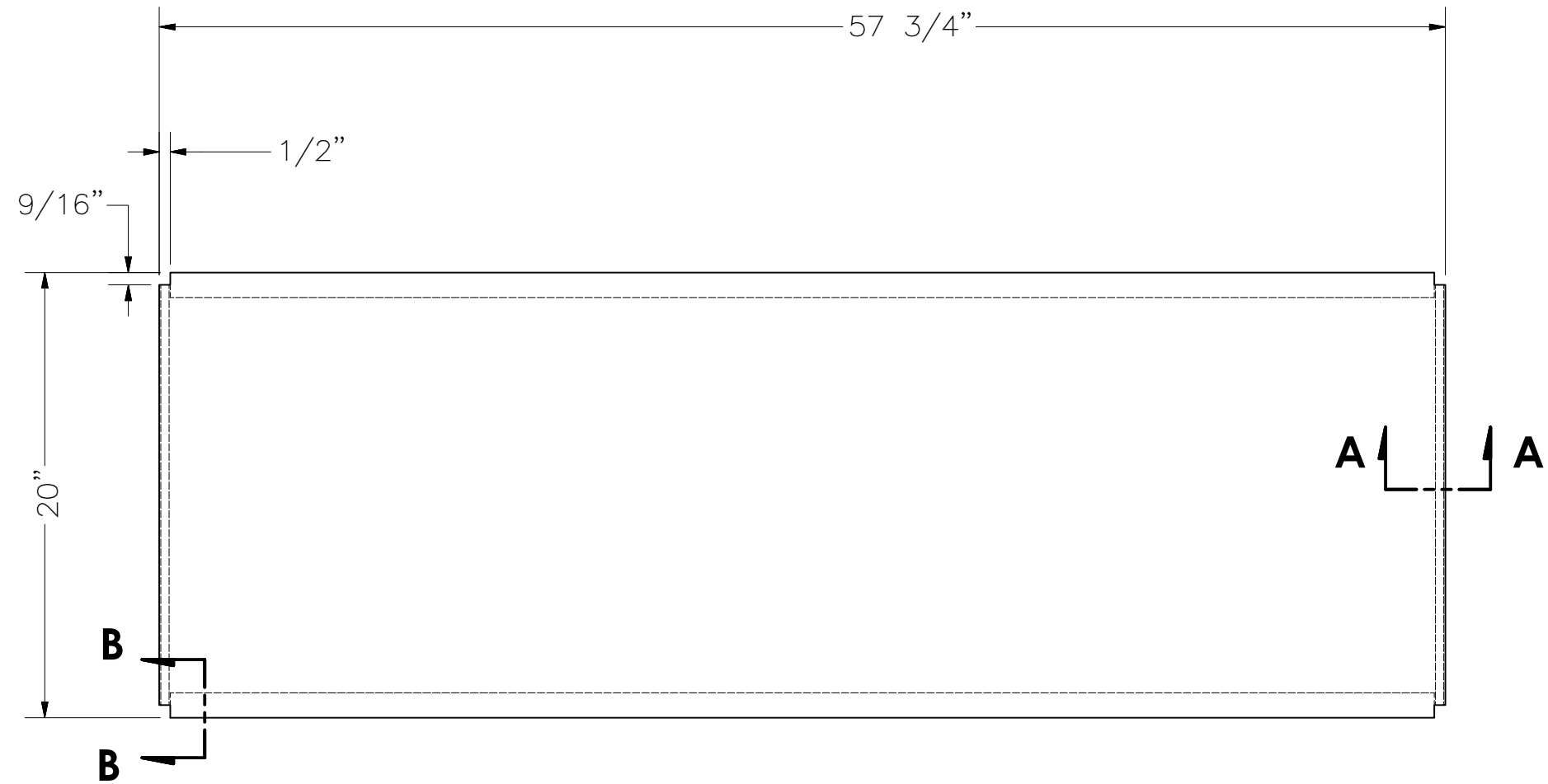

SECTION A-A

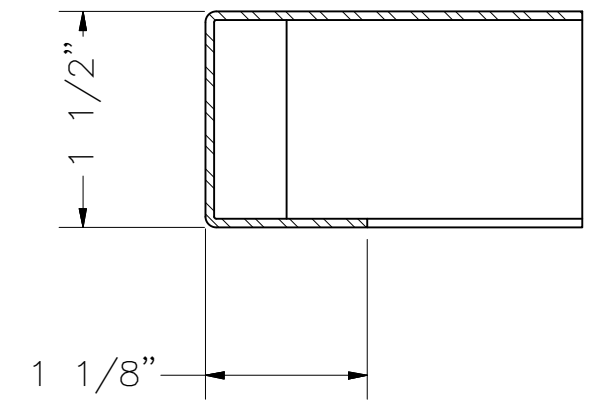

SECTION B-B

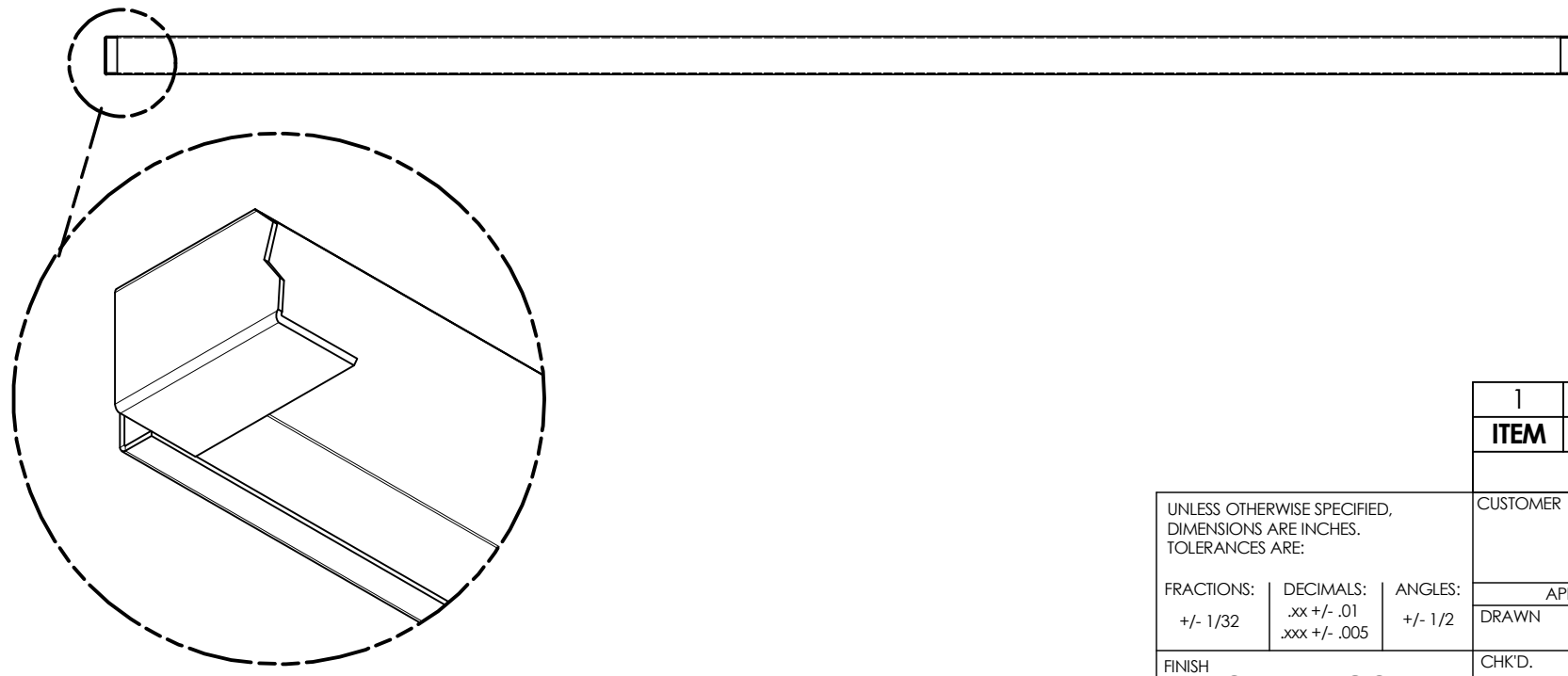

UNLESS OTHERWISE SPECIFIED,
DIMENSIONS ARE INCHES.
TOLERANCES ARE:

FRACTIONS: +/- 1/32	DECIMALS: .xx +/- .01 .xxx +/- .005	ANGLES: +/- 1/2
------------------------	---	--------------------

FINISH
**POWDER COAT
BRASS**

DO NOT SCALE DRAWING

1	R366	METAL SHEET 16GA. X 48" X 120" C.R.S.	1
ITEM	PART No.	DESCRIPTION	QTY.
BILL OF MATERIALS			
CUSTOMER FRED SEGAL		 Pico Rivera, CA. (562) 949-2535	
APPROVALS DRAWN JEL	DATE 4/9/2014		
CHK'D.		TITLE A22-H-02-CG METAL SHELF 20" X 57"	
APVD.		SIZE B	REV.
EQCB No.		DWG. No. 54000259	
		SCALE: N.T.S.	SHEET: 1 OF 2

THIS DRAWING IS THE EXCLUSIVE PROPERTY OF REEVE STORE EQUIPMENT CO. WHO HOLDS AND MAINTAINS FULL COPYRIGHT PROTECTION UNDER FEDERAL AND STATE LAW. THIS DRAWING CANNOT BE DUPLICATED, PHOTOCOPIED, DIGITALLY TRANSFERRED, OR REPRODUCED WITHOUT THE EXPRESS WRITTEN CONSENT OF REEVE STORE EQUIPMENT CO. COPYRIGHT 2012, 2011, 2010, 2009, 2008, 2007, 2006, 2005, 2004, 2003, 2002. ALL RIGHTS RESERVED.

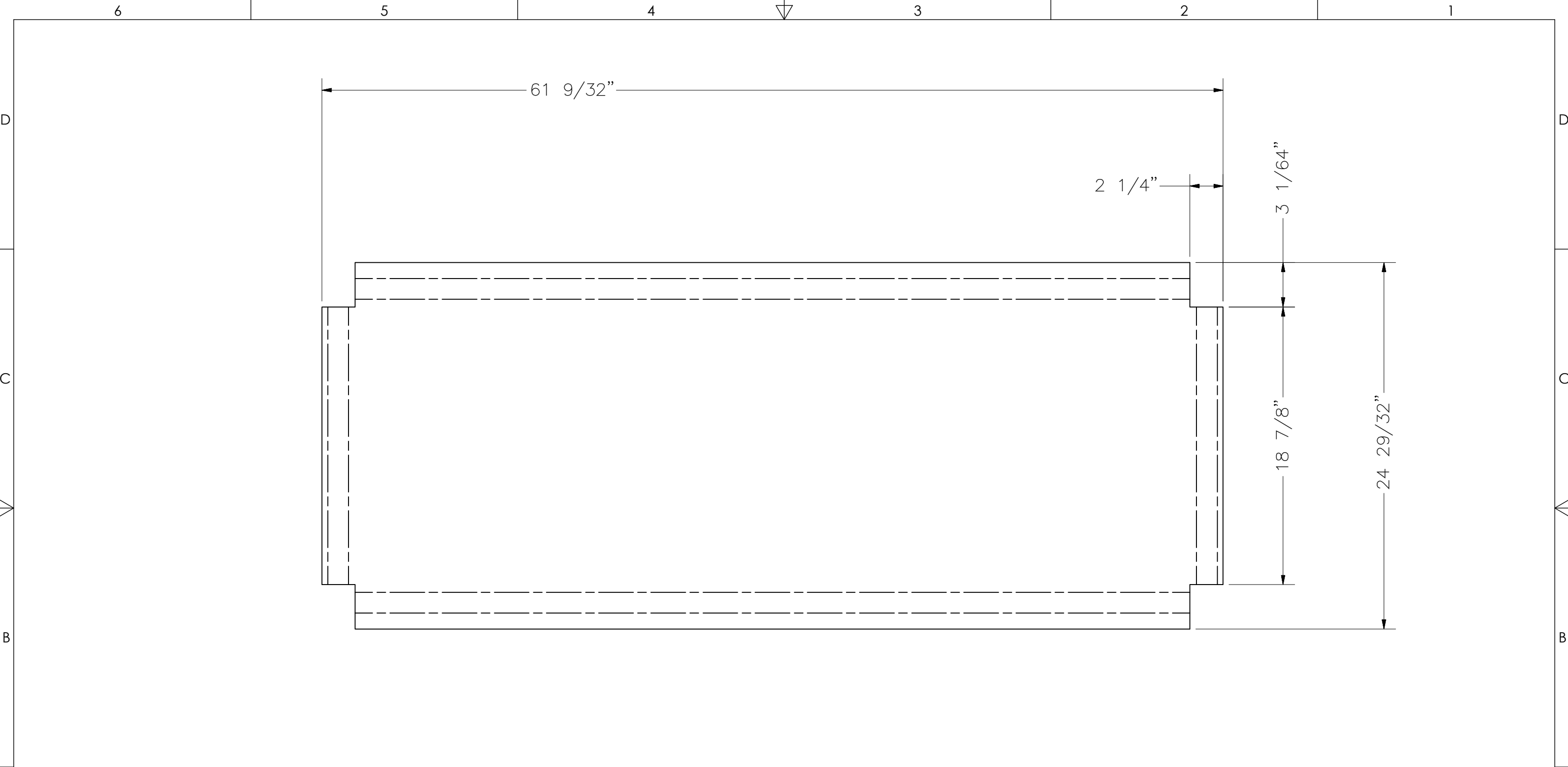

UNLESS OTHERWISE SPECIFIED,
DIMENSIONS ARE INCHES.
TOLERANCES ARE:

FRACTIONS: +/- 1/32	DECIMALS: .xx +/- .01 .xxx +/- .005	ANGLES: +/- 1/2
------------------------	---	--------------------

FINISH
**POWDER COAT
BRASS**

DO NOT SCALE DRAWING

CUSTOMER
FRED SEGAL

APPROVALS	DATE
DRAWN JEL	4/9/2014

CHK'D.	
APVD.	
EQCB No.	



STORE EQUIPMENT CO.
Pico Rivera, CA. (562) 949-2535

TITLE
A22-H-02-CG METAL SHELF 20" X 57"

SIZE B	DWG. No. 54000259	REV.
------------------	-----------------------------	------

SCALE: N.T.S.	SHEET: 2 OF 2
-------------------------	-------------------------