

APPLY  
UV/LED GLUE  
FROM MASTERBOND  
TO BOND DOOR  
FRAME, GLASS  
AND DRAWER  
PANEL

| 21   |             | LEVELER 1-3/8" BASE DIA., 3/8-16 X 1" STEM                            | 4    |
|------|-------------|---|------|
| 20   |             | THREAD FORMING SCREW 8-18 X 3/4" 316 S.S.<br>MCM#92525A825            | 20   |
| 19   | 92525A814   | PAN HEAD PHILLIPS SELF-THREADING SCREW 8-18 X 3/8"<br>STAINLESS STEEL | 8    |
| 18   | 91581A325   | LOCKNUT 8-32 WITH NYLON INSERT MCM#91581A325                          | 10   |
| 17   |             | FLATWASHER FOR #8 SCREW (3/8" OD X .04" THK) 316 S.S.                 | 4    |
| 16   |             | PAN HEAD PHILLIPS SCREW 8-32 X 1/2" MCM #90272A194                    | 10   |
| 15   | 62000967    | 22E-02-CG DISPLAY CASE GLASS FRONT PANEL                              | 1    |
| 14   |             | CAMLOCK 3/4" OD HOLE X 1-1/8" LG WITH OFFSET CAM                      | 1    |
| 13   | 62000966    | 22E-02-CG MENS DISPLAY CASE GLASS DOOR PANEL                          | 1    |
| 12   | 62000965    | 22E-02-CG MENS DISPLAY CASE GLASS SIDE PANEL                          | 2    |
| 11   | 62000964    | 22E-02-CG MENS DISPLAY CASE GLASS TOP                                 | 1    |
| 10   | 63835A360   | PARTIAL EXTENSION SIDE MOUNT DRAWER SLIDE 22" CLOSED<br>LENGTH        | 4    |
| 9    | 33001481    | 22E-02-CG MENS DISPLAY CASE BOTTOM FRAME PANEL                        | 1    |
| 8    | 33001480    | 22E-02-CG MENS DISPLAY CASE SIDE GLASS PANEL STOPPER                  | 4    |
| 7    | 33001479    | 22E-02-CG MENS DISPLAY CASE METAL TOP STRETCHER - KEY<br>SLOT         | 1    |
| 6    | 33001478    | 22E-02-CG MENS DISPLAY CASE METAL DRAWER BOTTOM<br>PANEL              | 1    |
| 5    | 33001477    | 22E-02-CG MENS DISPLAY CASE METAL BOTTOM GLASS<br>STRETCHER           | 1    |
| 4    | 33001476    | 22E-02-CG MENS DISPLAY CASE METAL TOP GASS STRETCHER                  | 1    |
| 3    | 33001475    | 22E-02-CG MENS DISPLAY CASE METAL DRAWER FRONT FRAME                  | 1    |
| 2    | 33001474-LH | 22E-02-CG MENS METAL TABLE FRAME -LEFT HAND                           | 1    |
| 1    | 33001474-RH | 22E-02-CG MENS METAL TABLE FRAME -RIGHT HAND                          | 1    |
| ITEM | PART No.    | DESCRIPTION   | QTY. |

BILL OF MATERIALS

|  |   |                               |                         |  |   |
|--|---|-------------------------------|-------------------------|--|---|
| UNLESS OTHERWISE SPECIFIED,<br>DIMENSIONS ARE INCHES.<br>TOLERANCES ARE: |   | CUSTOMER<br><b>FRED SEGAL</b> |                         | <br>STORE EQUIPMENT CO.<br>Pico Rivera, CA. (562) 949-2535 |   |
| FRACTIONS:<br>+/- 1/32   | DECIMALS:<br>.xx +/- .01<br>.xxx +/- .005 | ANGLES:<br>+/- 1/2            | APPROVALS               |  |   |
| FINISH<br><b>POWDER COAT<br/>BLACK</b>                                   |   |                               | DRAWN<br><b>JEL</b>     | 5/6/2014   | TITLE<br><b>22E-02-CG MENS DISPLAY CASE</b> |
| DO NOT SCALE DRAWING   |   |                               | CHK'D.                  |  | SIZE<br><b>B</b>                            |
|  |   |                               | APVD.                   |  | DWG. No.<br><b>49001317</b>                 |
|  |   |                               | EQCB No.                |  | REV.<br>1 OF 2                              |
|  |   |                               | SCALE:<br><b>N.T.S.</b> |  | SHEET:<br><b>1 OF 2</b>                     |

THIS DRAWING IS THE EXCLUSIVE PROPERTY OF REEVE STORE EQUIPMENT CO. WHO HOLDS AND MAINTAINS FULL COPYRIGHT PROTECTION UNDER FEDERAL AND STATE LAW. THIS DRAWING CANNOT BE DUPLICATED, PHOTOCOPIED, DIGITALLY TRANSFERRED, OR REPRODUCED WITHOUT THE EXPRESS WRITTEN CONSENT OF REEVE STORE EQUIPMENT CO. COPYRIGHT 2012, 2011, 2010, 2009, 2008, 2007, 2006, 2005, 2004, 2003, 2002. ALL RIGHTS RESERVED.

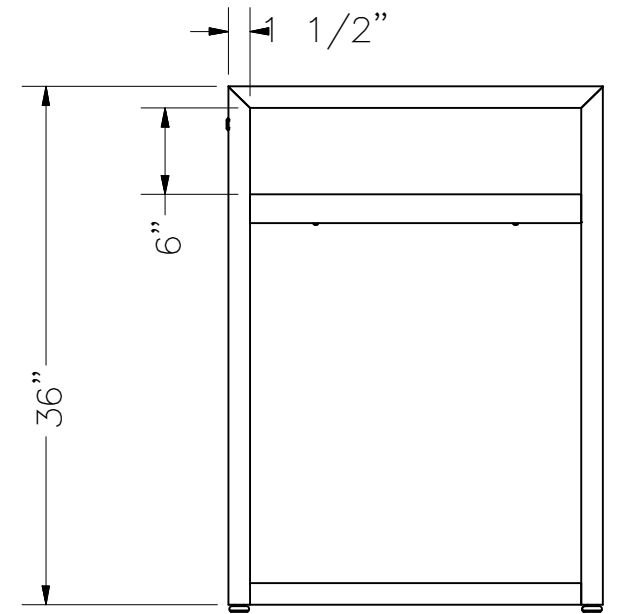
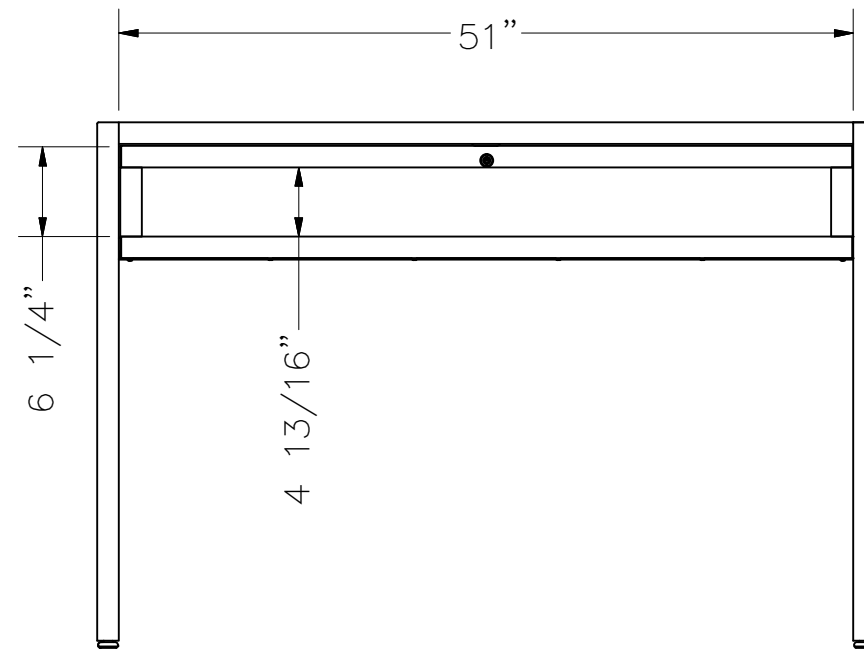
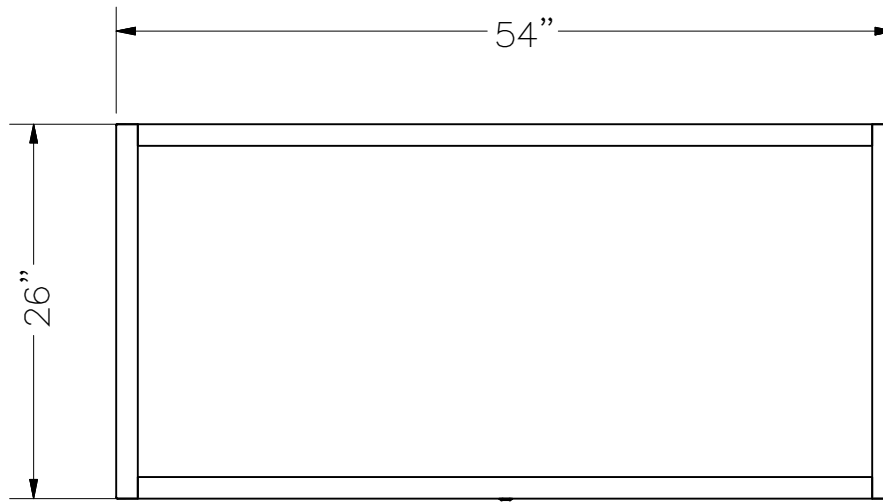
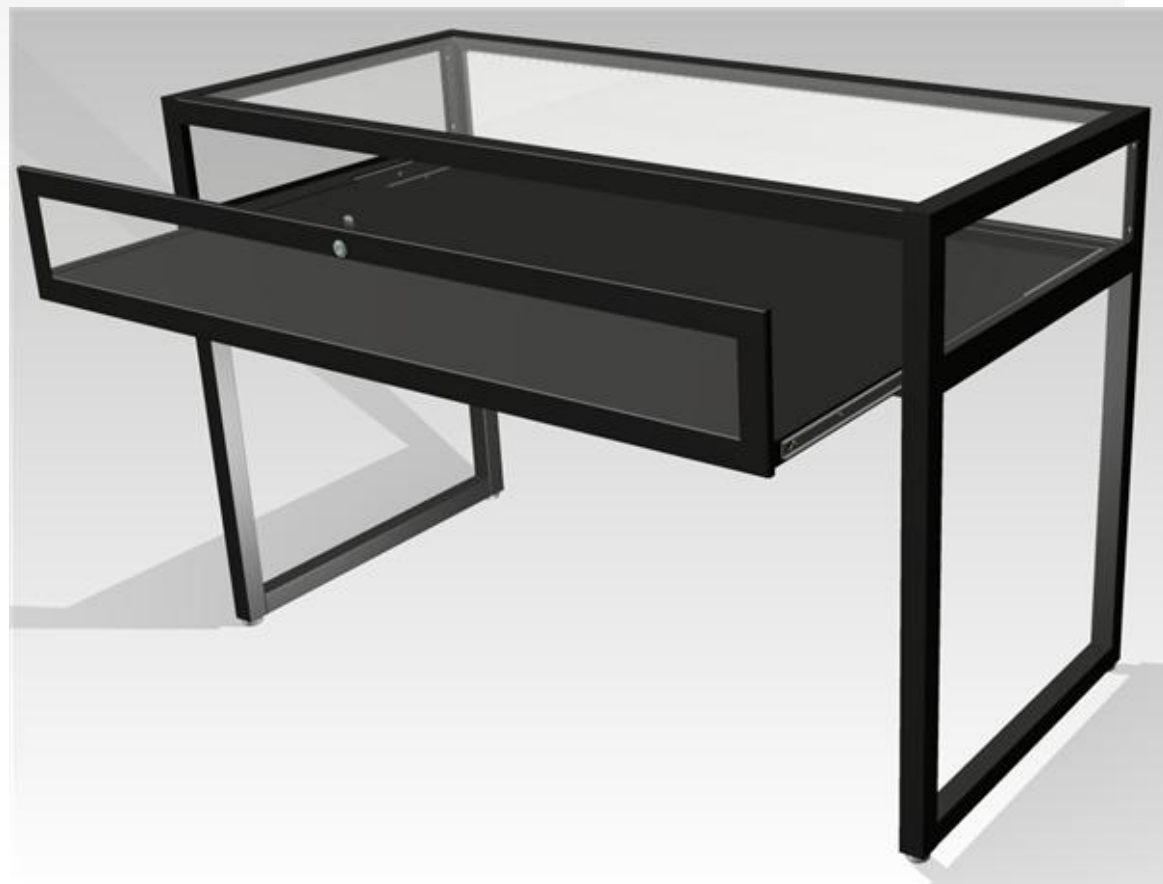
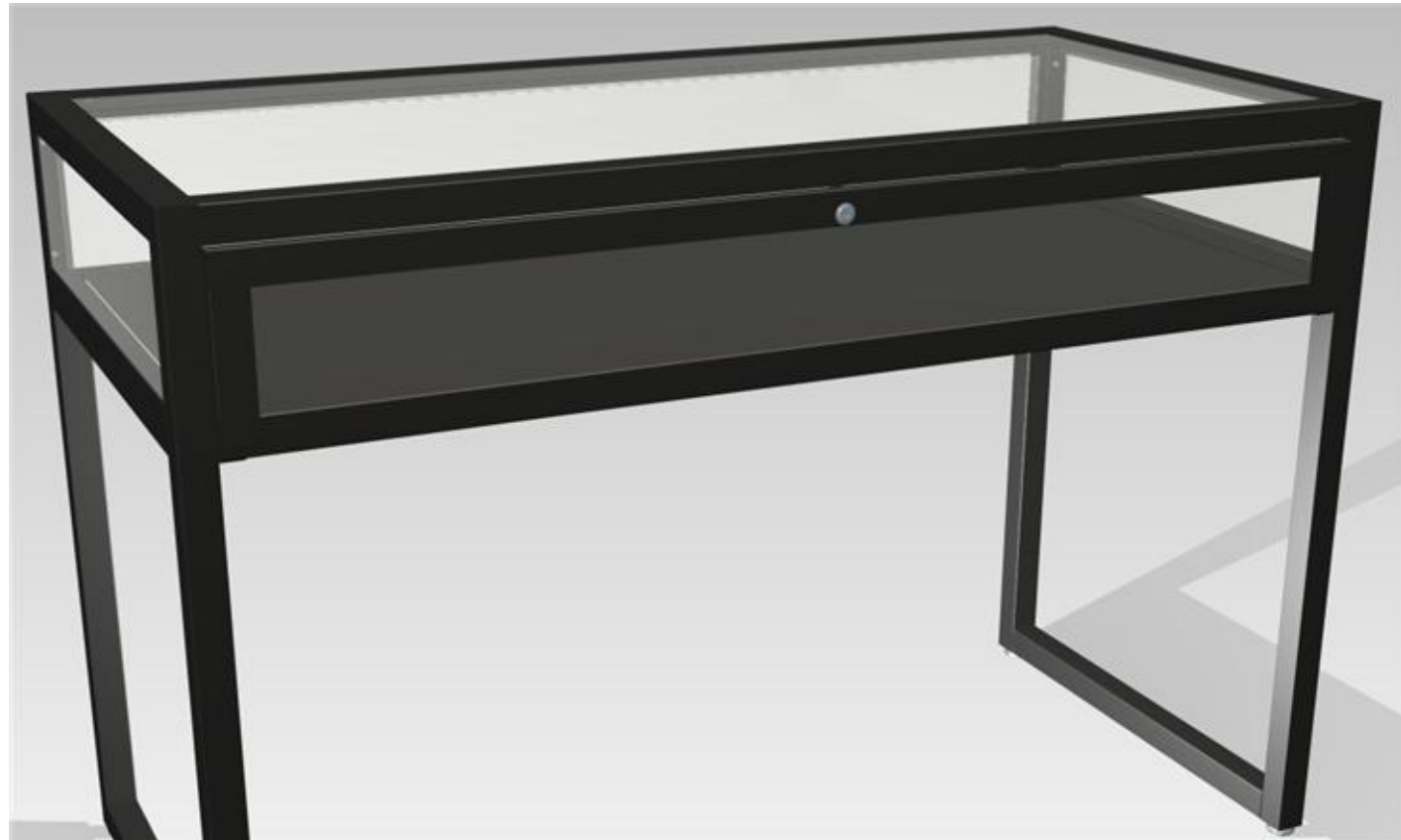

|  |   |                    |                               |          |
|--|---|--------------------|-------------------------------|----------|
| UNLESS OTHERWISE SPECIFIED, DIMENSIONS ARE INCHES. TOLERANCES ARE: |   |                    | CUSTOMER<br><b>FRED SEGAL</b> |          |
| FRACTIONS:<br>+/- 1/32   | DECIMALS:<br>.xx +/- .01<br>.xxx +/- .005 | ANGLES:<br>+/- 1/2 | APPROVALS                     | DATE     |
| FINISH<br><b>POWDER COAT<br/>BLACK</b>                             |   |                    | DRAWN<br><b>JEL</b>           | 5/6/2014 |
| <b>DO NOT SCALE DRAWING</b>  |   |                    | CHK'D.                        |          |
|  |   |                    | APVD.                         |          |
|  |   |                    | EQCB No.                      |          |

|                                     |                             |      |
|-------------------------------------|-----------------------------|------|
| <br>Pico Rivera, CA. (562) 949-2535 |                             |      |
| <b>22E-02-CG MENS DISPLAY CASE</b>  |                             |      |
| SIZE<br><b>B</b>                    | DWG. No.<br><b>49001317</b> | REV. |
| SCALE:<br><b>N.T.S.</b>             | SHEET:<br><b>2 OF 2</b>     |      |

THIS DRAWING IS THE EXCLUSIVE PROPERTY OF REEVE STORE EQUIPMENT CO. WHO HOLDS AND MAINTAINS FULL COPYRIGHT PROTECTION UNDER FEDERAL AND STATE LAW. THIS DRAWING CANNOT BE DUPLICATED, PHOTOCOPIED, DIGITALLY TRANSFERRED, OR REPRODUCED WITHOUT THE EXPRESS WRITTEN CONSENT OF REEVE STORE EQUIPMENT CO. COPYRIGHT 2012, 2011, 2010, 2009, 2008, 2007, 2006, 2005, 2004, 2003, 2002. ALL RIGHTS RESERVED.

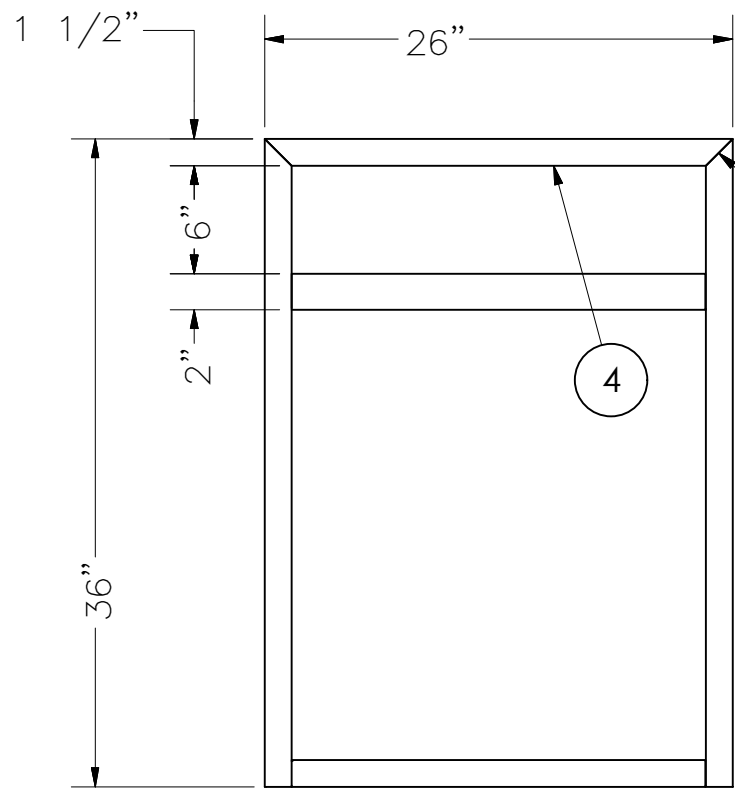
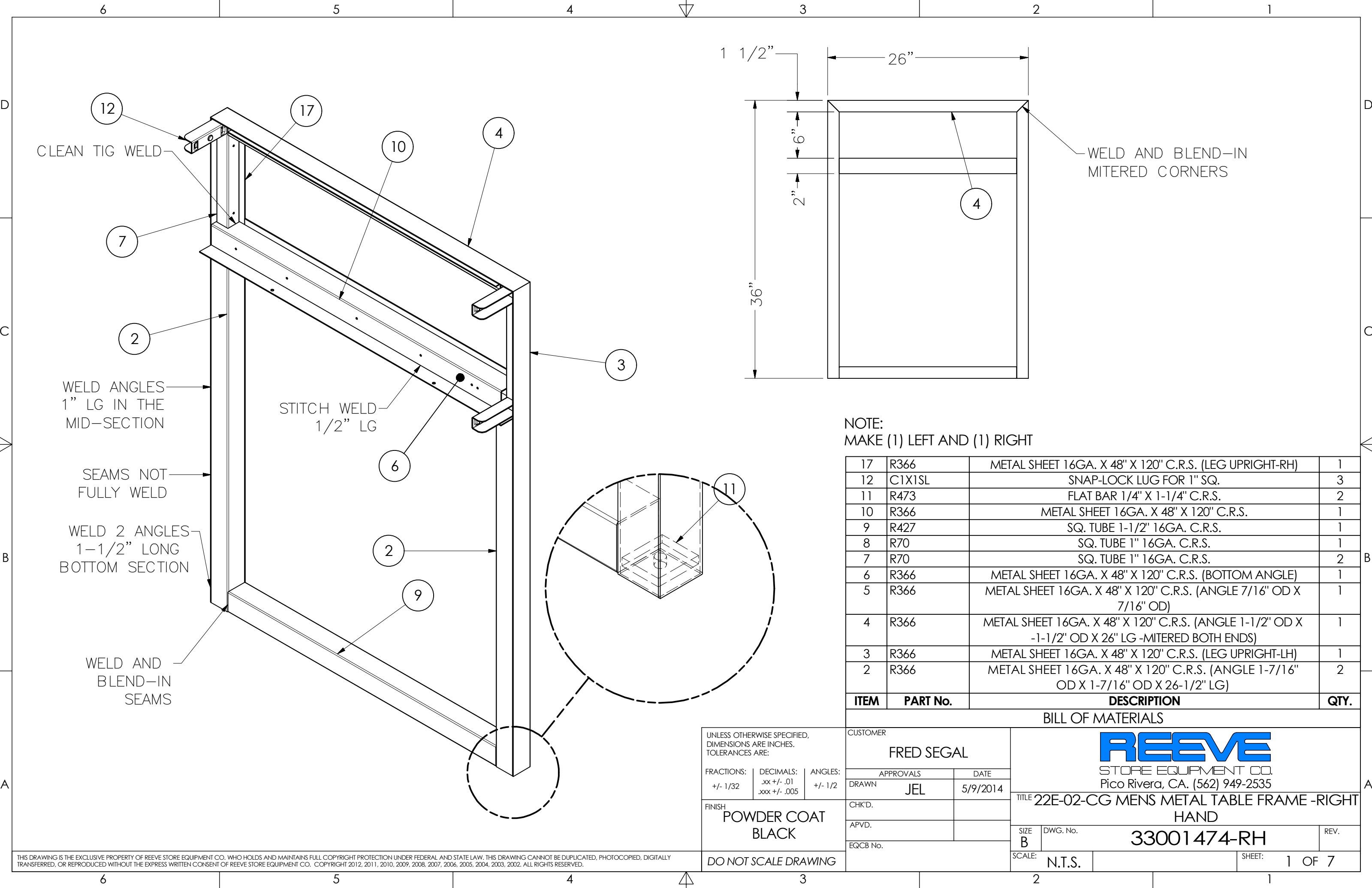

WELD AND BLEND-IN MITERED CORNERS

NOTE:  
MAKE (1) LEFT AND (1) RIGHT

| 17   | R366     | METAL SHEET 16GA. X 48" X 120" C.R.S. (LEG UPRIGHT-RH)   | 1    |
|------|----------|--|------|
| 12   | C1X1SL   | SNAP-LOCK LUG FOR 1" SQ.   | 3    |
| 11   | R473     | FLAT BAR 1/4" X 1-1/4" C.R.S.  | 2    |
| 10   | R366     | METAL SHEET 16GA. X 48" X 120" C.R.S.  | 1    |
| 9    | R427     | SQ. TUBE 1-1/2" 16GA. C.R.S.   | 1    |
| 8    | R70      | SQ. TUBE 1" 16GA. C.R.S.   | 1    |
| 7    | R70      | SQ. TUBE 1" 16GA. C.R.S.   | 2    |
| 6    | R366     | METAL SHEET 16GA. X 48" X 120" C.R.S. (BOTTOM ANGLE)   | 1    |
| 5    | R366     | METAL SHEET 16GA. X 48" X 120" C.R.S. (ANGLE 7/16" OD X 7/16" OD)                                | 1    |
| 4    | R366     | METAL SHEET 16GA. X 48" X 120" C.R.S. (ANGLE 1-1/2" OD X -1-1/2" OD X 26" LG -MITERED BOTH ENDS) | 1    |
| 3    | R366     | METAL SHEET 16GA. X 48" X 120" C.R.S. (LEG UPRIGHT-LH)   | 1    |
| 2    | R366     | METAL SHEET 16GA. X 48" X 120" C.R.S. (ANGLE 1-7/16" OD X 1-7/16" OD X 26-1/2" LG)               | 2    |
| ITEM | PART No. | DESCRIPTION  | QTY. |

BILL OF MATERIALS

UNLESS OTHERWISE SPECIFIED,  
DIMENSIONS ARE INCHES.  
TOLERANCES ARE:

|            |                              |         |
|------------|------------------------------|---------|
| FRACTIONS: | DECIMALS:                    | ANGLES: |
| +/- 1/32   | .xx +/- .01<br>.xxx +/- .005 | +/- 1/2 |

FINISH  
**POWDER COAT  
BLACK**

DO NOT SCALE DRAWING

CUSTOMER  
**FRED SEGAL**

|                  |          |
|------------------|----------|
| APPROVALS        | DATE     |
| DRAWN <b>JEL</b> | 5/9/2014 |
| CHK'D.           |          |
| APVD.            |          |
| EQCB No.         |          |

**REEVE**  
STORE EQUIPMENT CO.  
Pico Rivera, CA. (562) 949-2535

TITLE **22E-02-CG MENS METAL TABLE FRAME -RIGHT  
HAND**

|                         |                                |      |
|-------------------------|--------------------------------|------|
| SIZE<br><b>B</b>        | DWG. No.<br><b>33001474-RH</b> | REV. |
| SCALE:<br><b>N.T.S.</b> | SHEET:<br><b>1 OF 7</b>        |      |

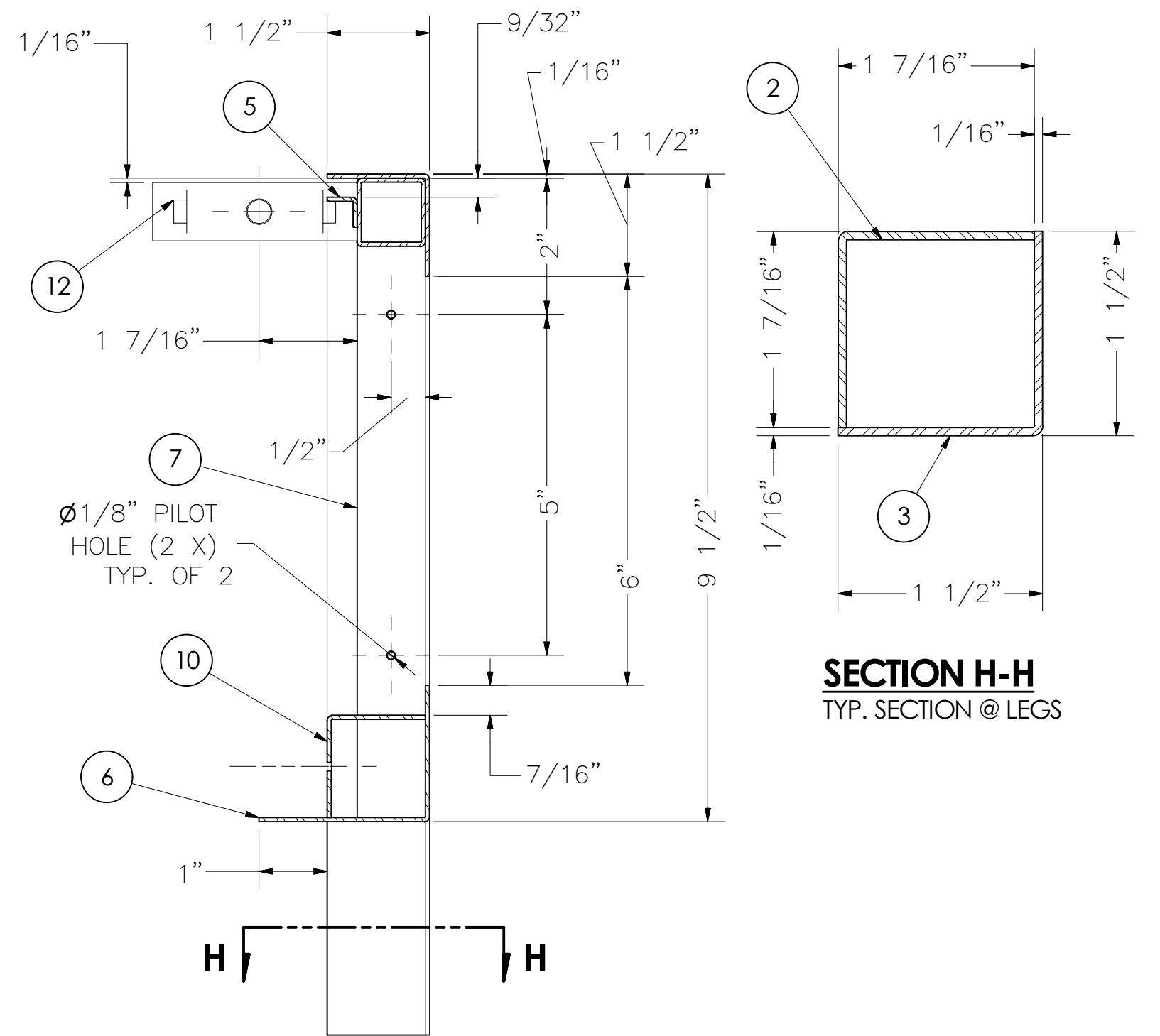
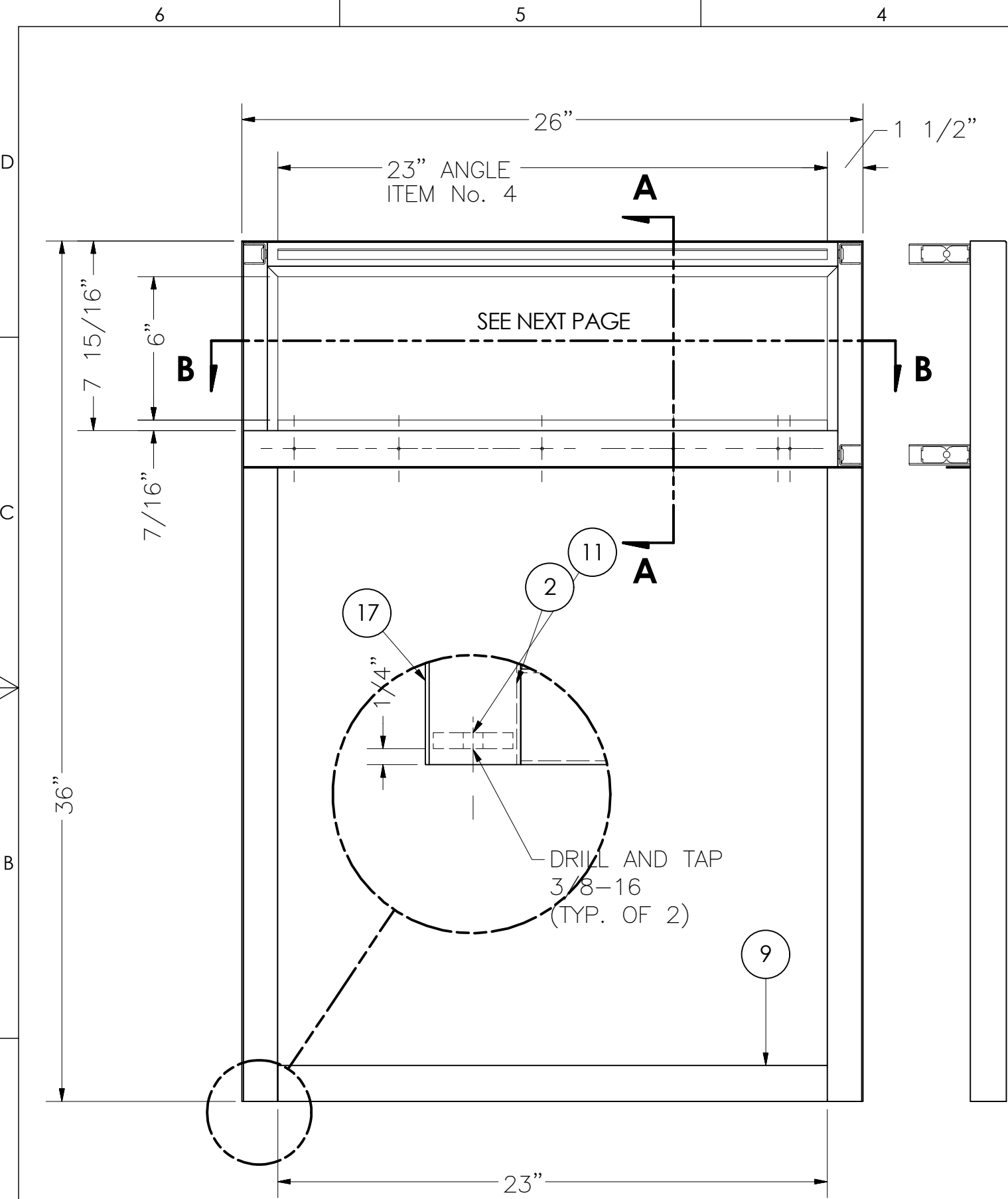

|   |  |        |  |           |  |
|---|--|--------|--|-----------|--|
| UNLESS OTHERWISE SPECIFIED,<br>DIMENSIONS ARE INCHES.<br>TOLERANCES ARE:<br><br>FRACTIONS:    DECIMALS:    ANGLES:<br>+/- 1/32    .xx +/- .01    +/- 1/2<br>.xxx +/- .005 | CUSTOMER<br><b>FRED SEGAL</b>          |        | <br>STORE EQUIPMENT CO.<br>Pico Rivera, CA. (562) 949-2535 |           |  |
|   | APPROVALS                              | DATE   |  |           |  |
|   | DRAWN                                  | JEL    | 5/9/2014   | TITLE     | 22E-02-CG MENS METAL TABLE FRAME -RIGHT HAND |
|   | FINISH<br><b>POWDER COAT<br/>BLACK</b> | CHK'D. |  | SIZE<br>B | DWG. No.<br><b>33001474-RH</b>               |
| DO NOT SCALE DRAWING  | APVD.                                  |        | SCALE:   | N.T.S.    |  |
|   | EQCB No.                               |        | SHEET:   | 2 OF 7    |  |

THIS DRAWING IS THE EXCLUSIVE PROPERTY OF REEVE STORE EQUIPMENT CO. WHO HOLDS AND MAINTAINS FULL COPYRIGHT PROTECTION UNDER FEDERAL AND STATE LAW. THIS DRAWING CANNOT BE DUPLICATED, PHOTOCOPIED, DIGITALLY TRANSFERRED, OR REPRODUCED WITHOUT THE EXPRESS WRITTEN CONSENT OF REEVE STORE EQUIPMENT CO. COPYRIGHT 2012, 2011, 2010, 2009, 2008, 2007, 2006, 2005, 2004, 2003, 2002. ALL RIGHTS RESERVED.

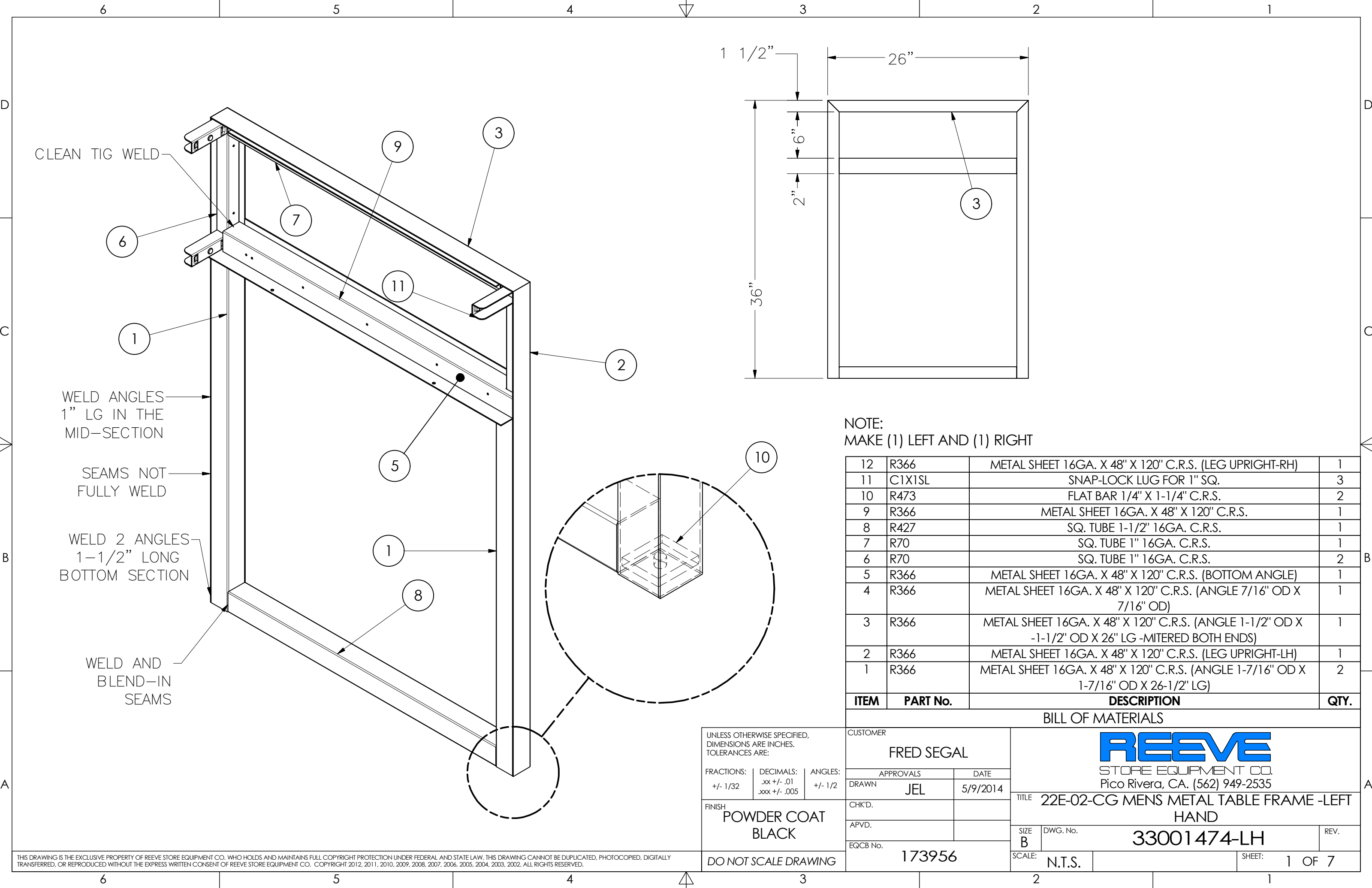

NOTE:  
MAKE (1) LEFT AND (1) RIGHT

| 12   | R366     | METAL SHEET 16GA. X 48" X 120" C.R.S. (LEG UPRIGHT-RH)   | 1    |
|------|----------|--|------|
| 11   | C1X1SL   | SNAP-LOCK LUG FOR 1" SQ.   | 3    |
| 10   | R473     | FLAT BAR 1/4" X 1-1/4" C.R.S.  | 2    |
| 9    | R366     | METAL SHEET 16GA. X 48" X 120" C.R.S.  | 1    |
| 8    | R427     | SQ. TUBE 1-1/2" 16GA. C.R.S.   | 1    |
| 7    | R70      | SQ. TUBE 1" 16GA. C.R.S.   | 1    |
| 6    | R70      | SQ. TUBE 1" 16GA. C.R.S.   | 2    |
| 5    | R366     | METAL SHEET 16GA. X 48" X 120" C.R.S. (BOTTOM ANGLE)   | 1    |
| 4    | R366     | METAL SHEET 16GA. X 48" X 120" C.R.S. (ANGLE 7/16" OD X 7/16" OD)                                | 1    |
| 3    | R366     | METAL SHEET 16GA. X 48" X 120" C.R.S. (ANGLE 1-1/2" OD X -1-1/2" OD X 26" LG -MITERED BOTH ENDS) | 1    |
| 2    | R366     | METAL SHEET 16GA. X 48" X 120" C.R.S. (LEG UPRIGHT-LH)   | 1    |
| 1    | R366     | METAL SHEET 16GA. X 48" X 120" C.R.S. (ANGLE 1-7/16" OD X 1-7/16" OD X 26-1/2" LG)               | 2    |
| ITEM | PART No. | DESCRIPTION  | QTY. |

BILL OF MATERIALS

|  |   |                               |                           |
|--|---|-------------------------------|---------------------------|
| UNLESS OTHERWISE SPECIFIED, DIMENSIONS ARE INCHES. TOLERANCES ARE: |   | CUSTOMER<br><b>FRED SEGAL</b> |                           |
| FRACTIONS:<br>+/- 1/32   | DECIMALS:<br>.xx +/- .01<br>.xxx +/- .005 | ANGLES:<br>+/- 1/2            | APPROVALS                 |
| FINISH<br><b>POWDER COAT BLACK</b>                                 |   |                               | DATE<br>5/9/2014          |
| DO NOT SCALE DRAWING   |   |                               | CHK'D.                    |
|  |   |                               | APVD.                     |
|  |   |                               | EQCB No.<br><b>173956</b> |

**REEVE**  
STORE EQUIPMENT CO.  
Pico Rivera, CA. (562) 949-2535

TITLE: **22E-02-CG MENS METAL TABLE FRAME -LEFT HAND**

SIZE: **B** DWG. No. **33001474-LH** REV.

SCALE: **N.T.S.** SHEET: **1 OF 7**

THIS DRAWING IS THE EXCLUSIVE PROPERTY OF REEVE STORE EQUIPMENT CO. WHO HOLDS AND MAINTAINS FULL COPYRIGHT PROTECTION UNDER FEDERAL AND STATE LAW. THIS DRAWING CANNOT BE DUPLICATED, PHOTOCOPIED, DIGITALLY TRANSFERRED, OR REPRODUCED WITHOUT THE EXPRESS WRITTEN CONSENT OF REEVE STORE EQUIPMENT CO. COPYRIGHT 2012, 2011, 2010, 2009, 2008, 2007, 2006, 2005, 2004, 2003, 2002. ALL RIGHTS RESERVED.

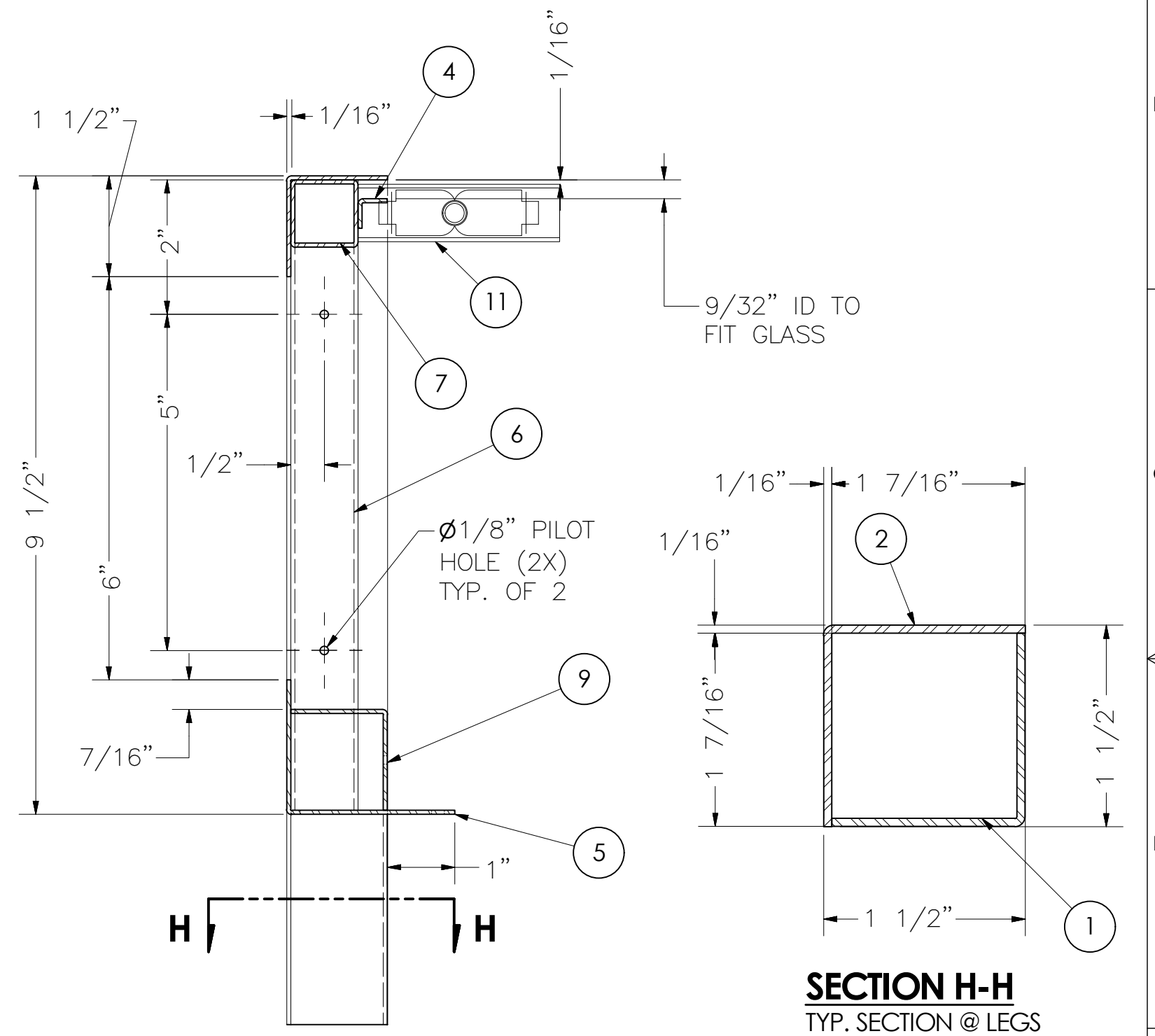
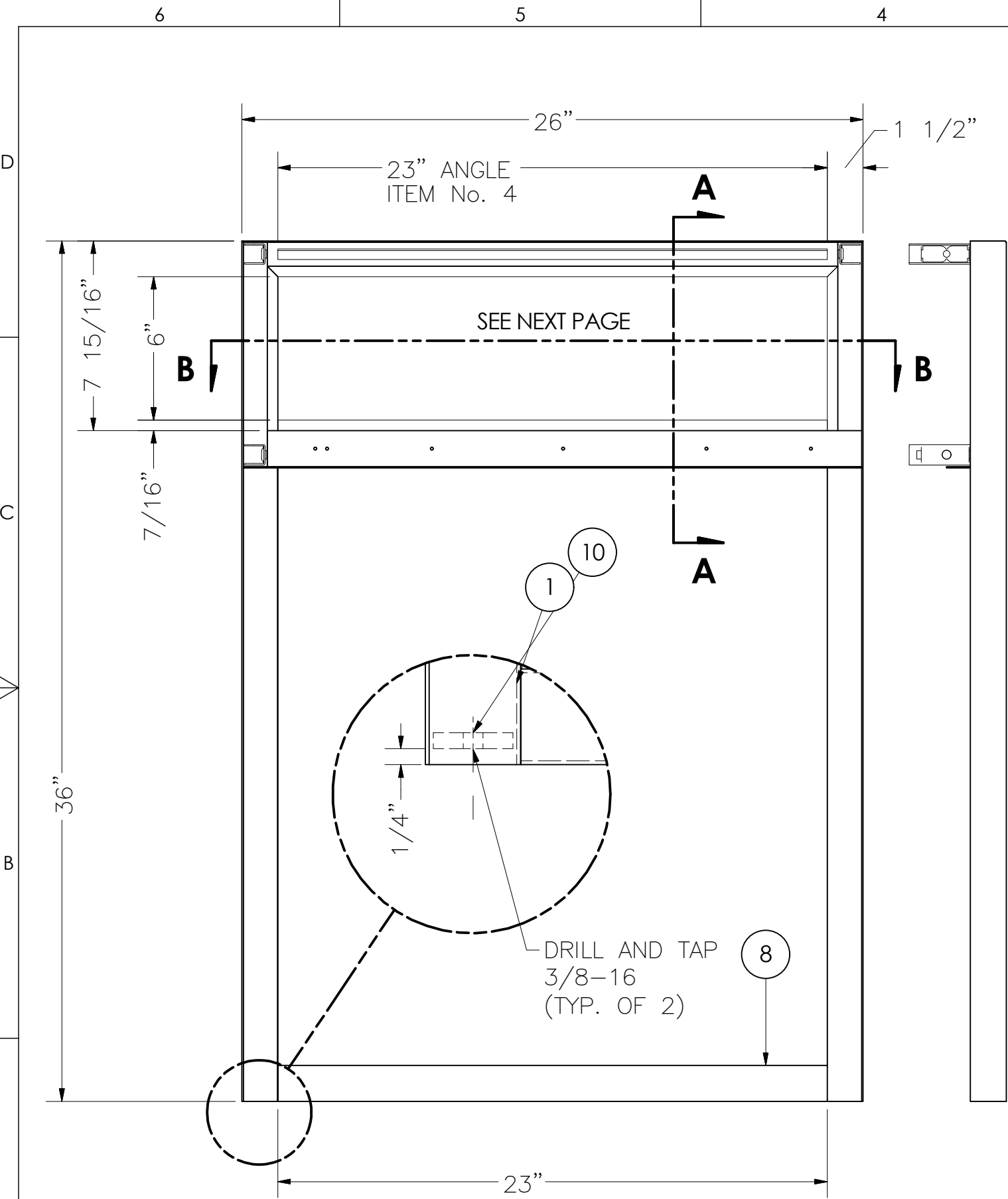

|  |   |                               |                           |  |   |
|--|---|-------------------------------|---------------------------|--|---|
| UNLESS OTHERWISE SPECIFIED, DIMENSIONS ARE INCHES. TOLERANCES ARE: |   | CUSTOMER<br><b>FRED SEGAL</b> |                           | <br>STORE EQUIPMENT CO.<br>Pico Rivera, CA. (562) 949-2535 |   |
| FRACTIONS:<br>+/- 1/32   | DECIMALS:<br>.xx +/- .01<br>.xxx +/- .005 | ANGLES:<br>+/- 1/2            | APPROVALS                 |  |   |
| FINISH<br><b>POWDER COAT BLACK</b>                                 |   |                               | DRAWN<br><b>JEL</b>       | 5/9/2014   | TITLE<br><b>22E-02-CG MENS METAL TABLE FRAME -LEFT HAND</b> |
| DO NOT SCALE DRAWING   |   |                               | EQCB No.<br><b>173956</b> | SIZE<br><b>B</b>   | DWG. No.<br><b>33001474-LH</b>                              |
|  |   |                               |                           | SCALE:<br><b>N.T.S.</b>                                    | REV.<br><b>2 OF 7</b>                                       |

THIS DRAWING IS THE EXCLUSIVE PROPERTY OF REEVE STORE EQUIPMENT CO. WHO HOLDS AND MAINTAINS FULL COPYRIGHT PROTECTION UNDER FEDERAL AND STATE LAW. THIS DRAWING CANNOT BE DUPLICATED, PHOTOCOPIED, DIGITALLY TRANSFERRED, OR REPRODUCED WITHOUT THE EXPRESS WRITTEN CONSENT OF REEVE STORE EQUIPMENT CO. COPYRIGHT 2012, 2011, 2010, 2009, 2008, 2007, 2006, 2005, 2004, 2003, 2002. ALL RIGHTS RESERVED.

CLEAN TIG WELD

FLUSH WHEN ALL COMPONENTS ASSEMBLED

WELD ANGLES 1" LG IN THE MID-SECTION

STITCH WELD 1/2" LG

SEAMS NOT FULLY WELD

WELD 2 ANGLES 1-1/2" LONG BOTTOM SECTION

WELD AND BLEND-IN SEAMS

UNLESS OTHERWISE SPECIFIED, DIMENSIONS ARE INCHES. TOLERANCES ARE:

|            |                              |         |
|------------|------------------------------|---------|
| FRACTIONS: | DECIMALS:                    | ANGLES: |
| +/- 1/32   | .xx +/- .01<br>.xxx +/- .005 | +/- 1/2 |

FINISH  
POWDER COAT  
BLACK

DO NOT SCALE DRAWING

CUSTOMER

FRED SEGAL

|           |          |
|-----------|----------|
| APPROVALS | DATE     |
| DRAWN JEL | 5/9/2014 |

CHK'D.

APVD.

EQCB No. 173956

**REEVE**

STORE EQUIPMENT CO.  
Pico Rivera, CA. (562) 949-2535

TITLE 22E-02-CG MENS METAL TABLE FRAME -LEFT HAND

|        |                      |      |
|--------|----------------------|------|
| SIZE B | DWG. No. 33001474-LH | REV. |
|--------|----------------------|------|

|               |               |
|---------------|---------------|
| SCALE: N.T.S. | SHEET: 3 OF 7 |
|---------------|---------------|

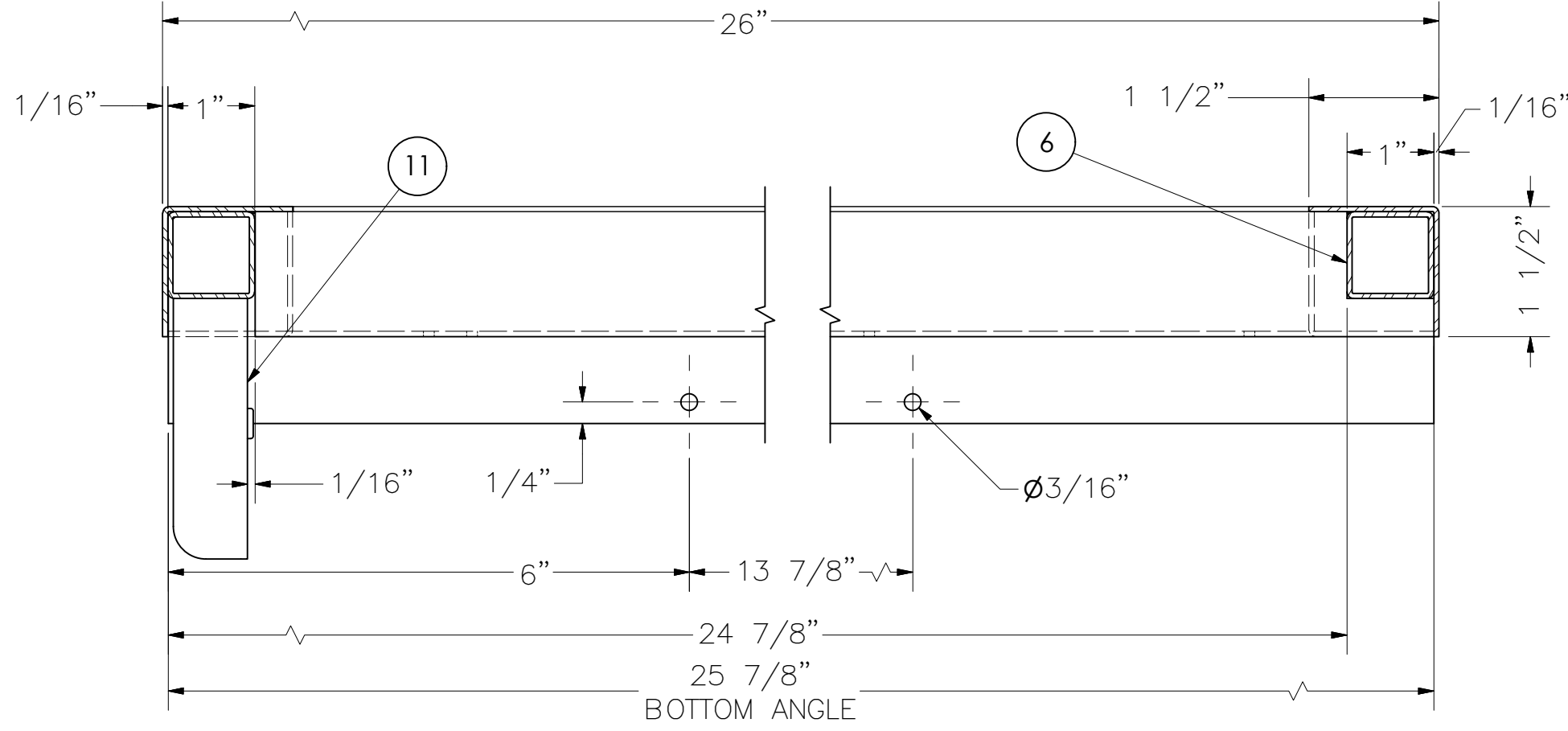

**SECTION B-B**

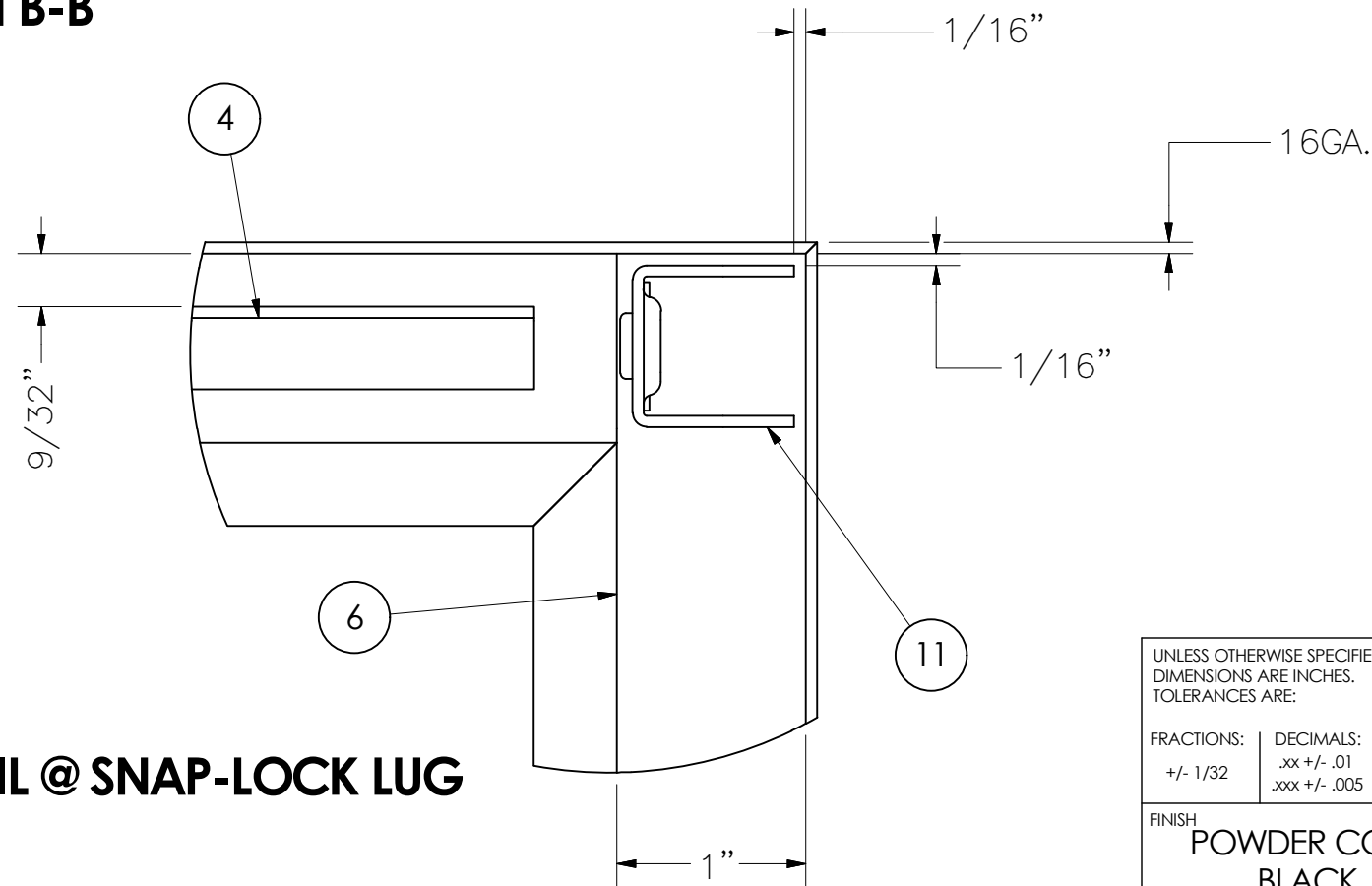

**DETAIL @ SNAP-LOCK LUG**

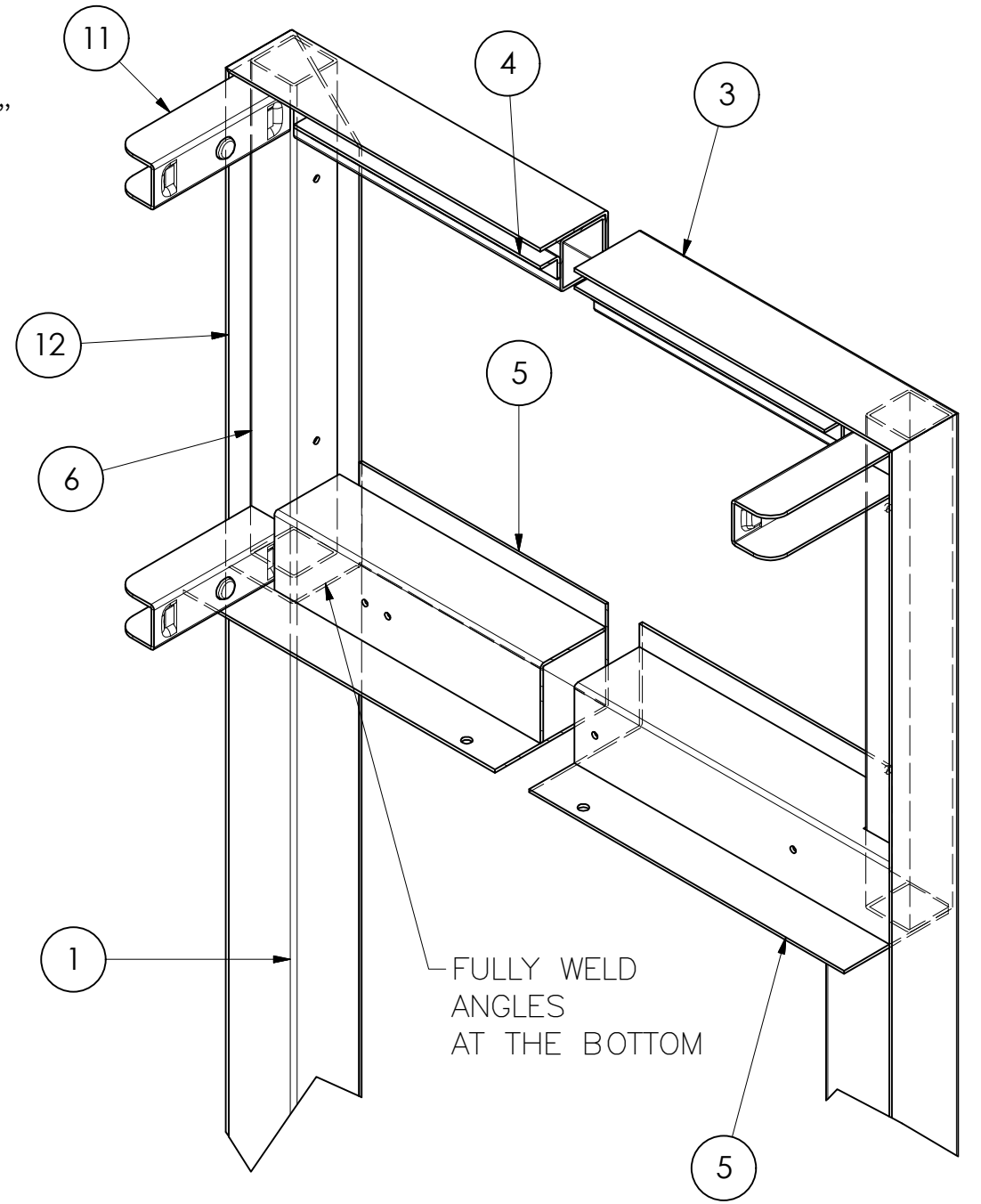

FULLY WELD  
ANGLES  
AT THE BOTTOM

|  |   |                    |                               |                                |   |
|--|---|--------------------|-------------------------------|--------------------------------|---|
| UNLESS OTHERWISE SPECIFIED,<br>DIMENSIONS ARE INCHES.<br>TOLERANCES ARE: |   |                    | CUSTOMER<br><b>FRED SEGAL</b> |                                | <br>Pico Rivera, CA. (562) 949-2535                             |
| FRACTIONS:<br>+/- 1/32   | DECIMALS:<br>.xx +/- .01<br>.xxx +/- .005 | ANGLES:<br>+/- 1/2 | APPROVALS                     | DATE                           |   |
| FINISH<br><b>POWDER COAT<br/>BLACK</b>                                   |   |                    | DRAWN<br><b>JEL</b>           | 5/9/2014                       | TITLE<br><b>22E-02-CG MENS METAL TABLE FRAME -LEFT<br/>HAND</b> |
| <b>DO NOT SCALE DRAWING</b>  |   |                    | EQCB No.<br><b>173956</b>     | DWG. No.<br><b>33001474-LH</b> | REV.  |
|  |   |                    | SCALE:<br><b>N.T.S.</b>       | SHEET:<br><b>4 OF 7</b>        |   |

THIS DRAWING IS THE EXCLUSIVE PROPERTY OF REEVE STORE EQUIPMENT CO. WHO HOLDS AND MAINTAINS FULL COPYRIGHT PROTECTION UNDER FEDERAL AND STATE LAW. THIS DRAWING CANNOT BE DUPLICATED, PHOTOCOPIED, DIGITALLY TRANSFERRED, OR REPRODUCED WITHOUT THE EXPRESS WRITTEN CONSENT OF REEVE STORE EQUIPMENT CO. COPYRIGHT 2012, 2011, 2010, 2009, 2008, 2007, 2006, 2005, 2004, 2003, 2002. ALL RIGHTS RESERVED.



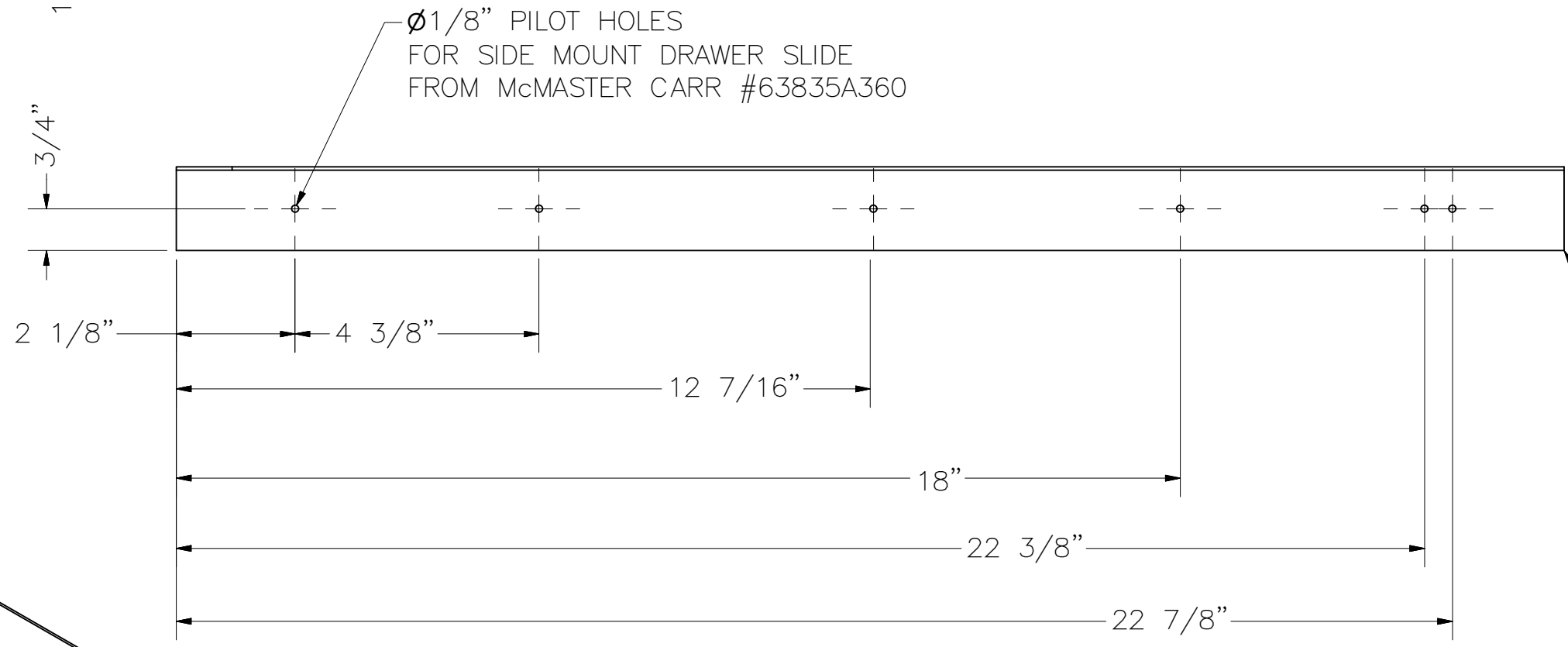
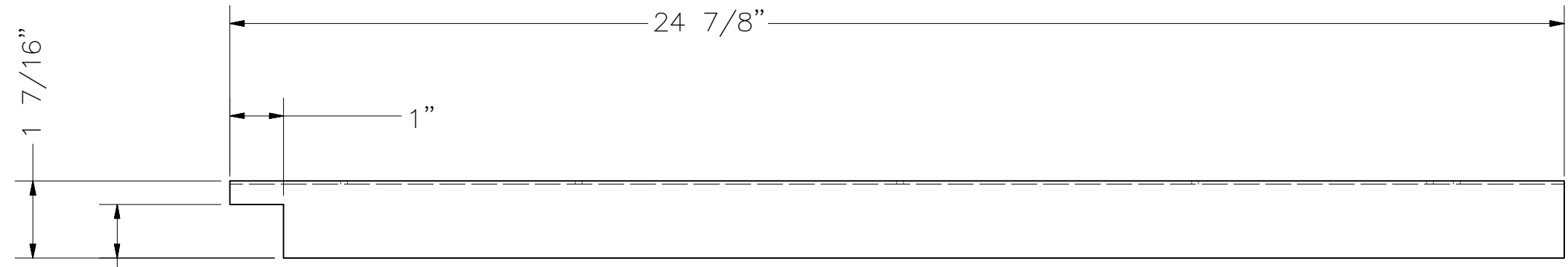

Ø1/8" PILOT HOLES  
FOR SIDE MOUNT DRAWER SLIDE  
FROM McMASTER CARR #63835A360

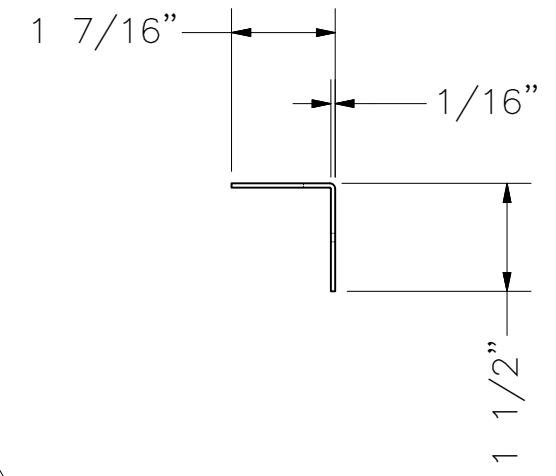

9

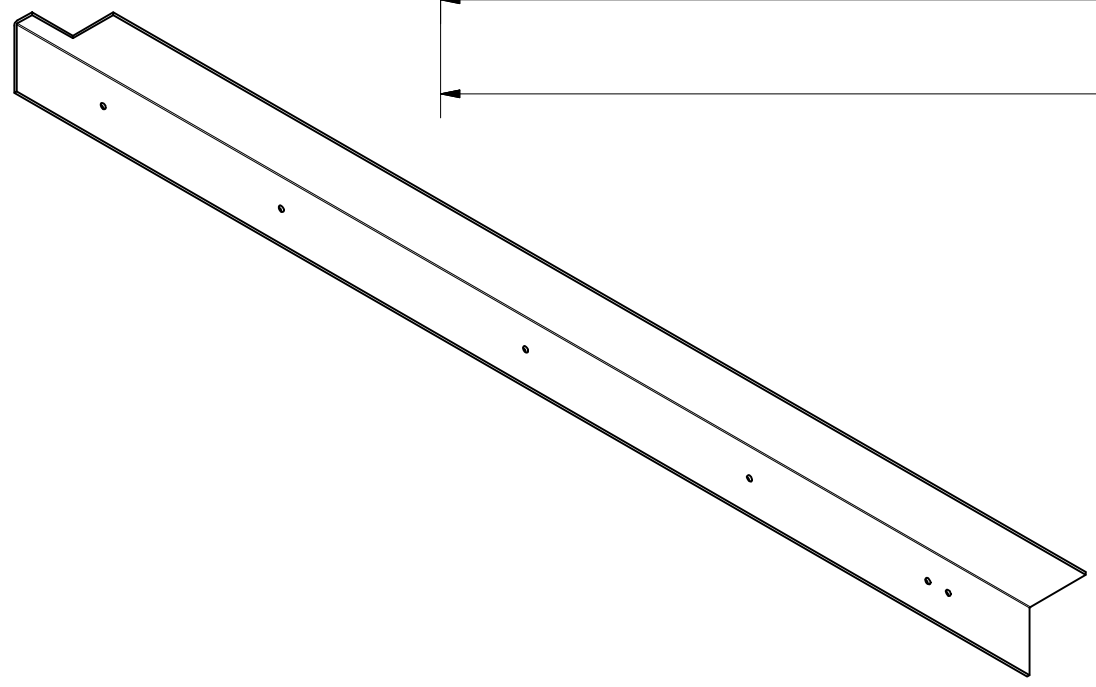

|  |   |                    |                               |          |
|--|---|--------------------|-------------------------------|----------|
| UNLESS OTHERWISE SPECIFIED,<br>DIMENSIONS ARE INCHES.<br>TOLERANCES ARE: |   |                    | CUSTOMER<br><b>FRED SEGAL</b> |          |
| FRACTIONS:<br>+/- 1/32   | DECIMALS:<br>.xx +/- .01<br>.xxx +/- .005 | ANGLES:<br>+/- 1/2 | APPROVALS                     | DATE     |
| FINISH<br><b>POWDER COAT<br/>BLACK</b>                                   |   |                    | DRAWN<br><b>JEL</b>           | 5/9/2014 |
| DO NOT SCALE DRAWING   |   |                    | CHK'D.                        |          |
|  |   |                    | APVD.                         |          |
|  |   |                    | EQCB No.<br><b>173956</b>     |          |

|  |                                |      |
|--|--------------------------------|------|
| <b>REEVE</b><br>STORE EQUIPMENT CO.<br>Pico Rivera, CA. (562) 949-2535 |                                |      |
| TITLE <b>22E-02-CG MENS METAL TABLE FRAME -LEFT<br/>HAND</b>           |                                |      |
| SIZE<br><b>B</b>   | DWG. No.<br><b>33001474-LH</b> | REV. |
| SCALE:<br><b>N.T.S.</b>  | SHEET:<br><b>5 OF 7</b>        |      |

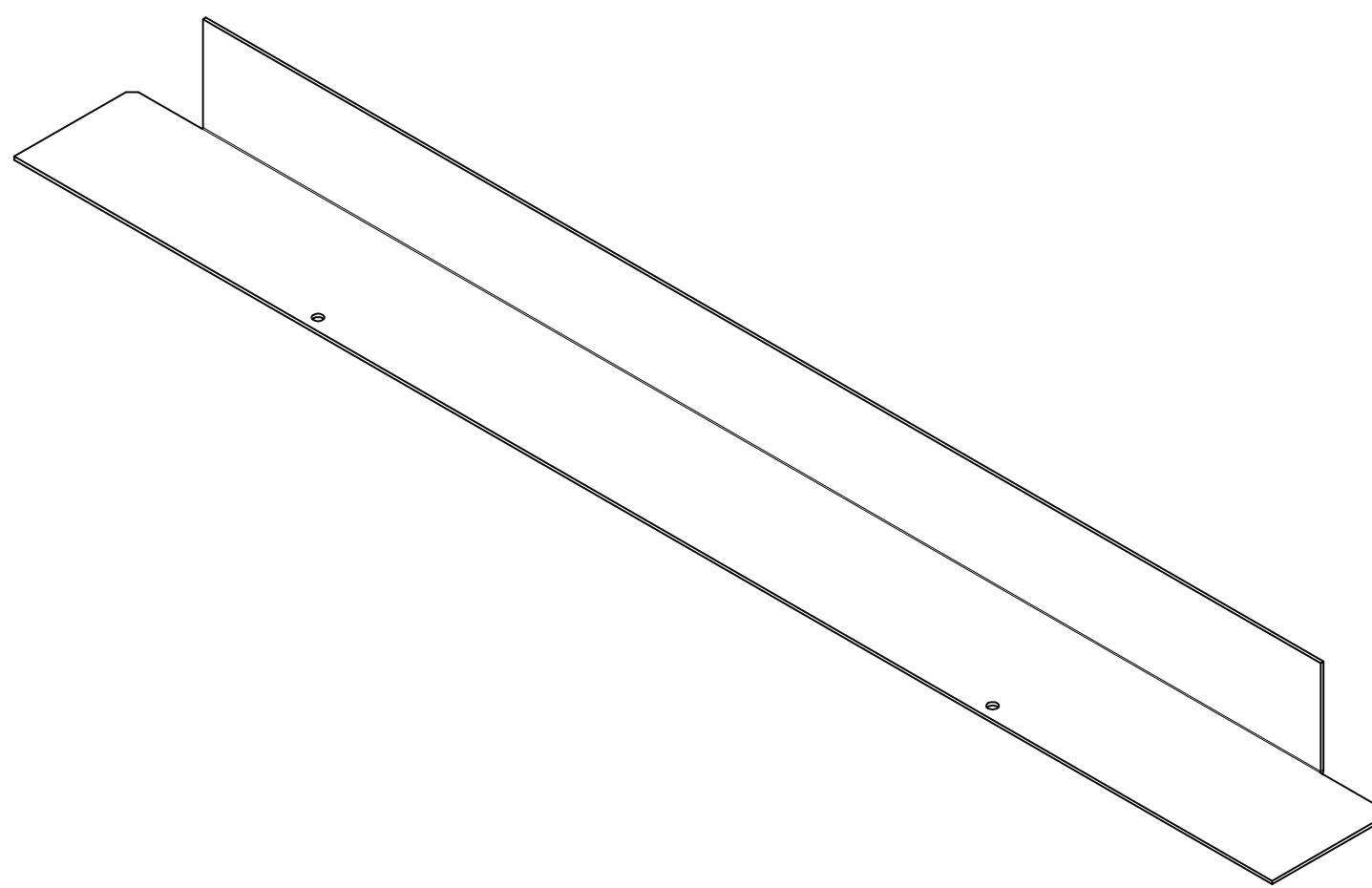
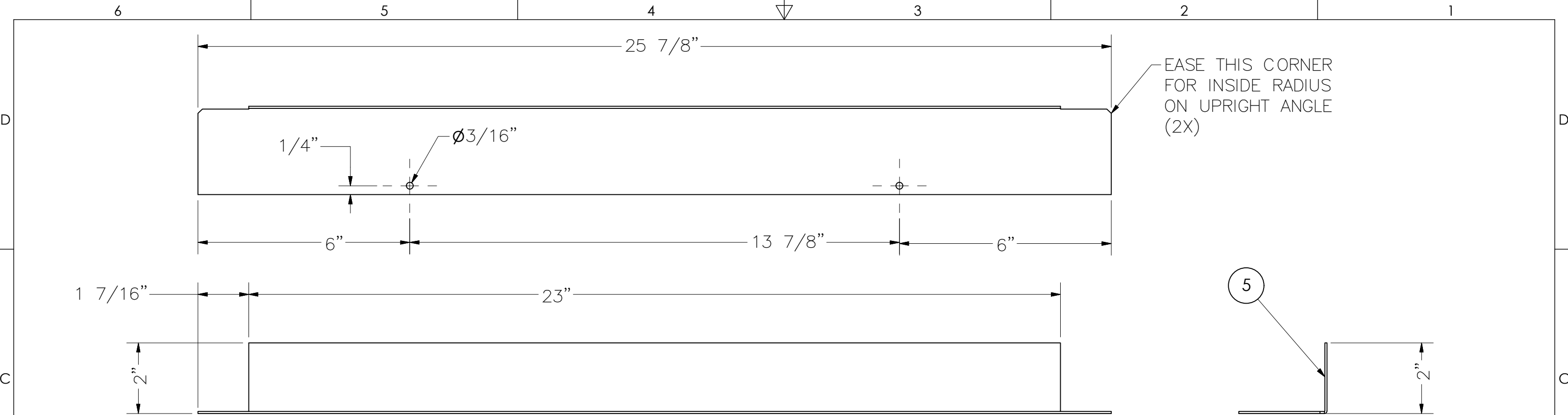

|  |   |                    |                               |          |  |
|--|---|--------------------|-------------------------------|----------|--|
| UNLESS OTHERWISE SPECIFIED, DIMENSIONS ARE INCHES. TOLERANCES ARE: |   |                    | CUSTOMER<br><b>FRED SEGAL</b> |          | <br>STORE EQUIPMENT CO.<br>Pico Rivera, CA. (562) 949-2535   |
| FRACTIONS:<br>+/- 1/32   | DECIMALS:<br>.xx +/- .01<br>.xxx +/- .005 | ANGLES:<br>+/- 1/2 | APPROVALS                     | DATE     |  |
| FINISH<br><b>POWDER COAT BLACK</b>                                 |   |                    | DRAWN<br><b>JEL</b>           | 5/9/2014 | TITLE<br><b>22E-02-CG MENS METAL TABLE FRAME -RIGHT HAND</b> |
| DO NOT SCALE DRAWING   |   |                    | CHK'D.                        |          | SIZE<br><b>B</b>   |
|  |   |                    | APVD.                         |          | DWG. No.<br><b>33001474-RH</b>                               |
|  |   |                    | EQCB No.<br><b>173956</b>     |          | REV.   |
|  |   |                    |                               |          | SCALE:<br><b>N.T.S.</b>                                      |
|  |   |                    |                               |          | SHEET:<br><b>6 OF 7</b>                                      |

THIS DRAWING IS THE EXCLUSIVE PROPERTY OF REEVE STORE EQUIPMENT CO. WHO HOLDS AND MAINTAINS FULL COPYRIGHT PROTECTION UNDER FEDERAL AND STATE LAW. THIS DRAWING CANNOT BE DUPLICATED, PHOTOCOPIED, DIGITALLY TRANSFERRED, OR REPRODUCED WITHOUT THE EXPRESS WRITTEN CONSENT OF REEVE STORE EQUIPMENT CO. COPYRIGHT 2012, 2011, 2010, 2009, 2008, 2007, 2006, 2005, 2004, 2003, 2002. ALL RIGHTS RESERVED.

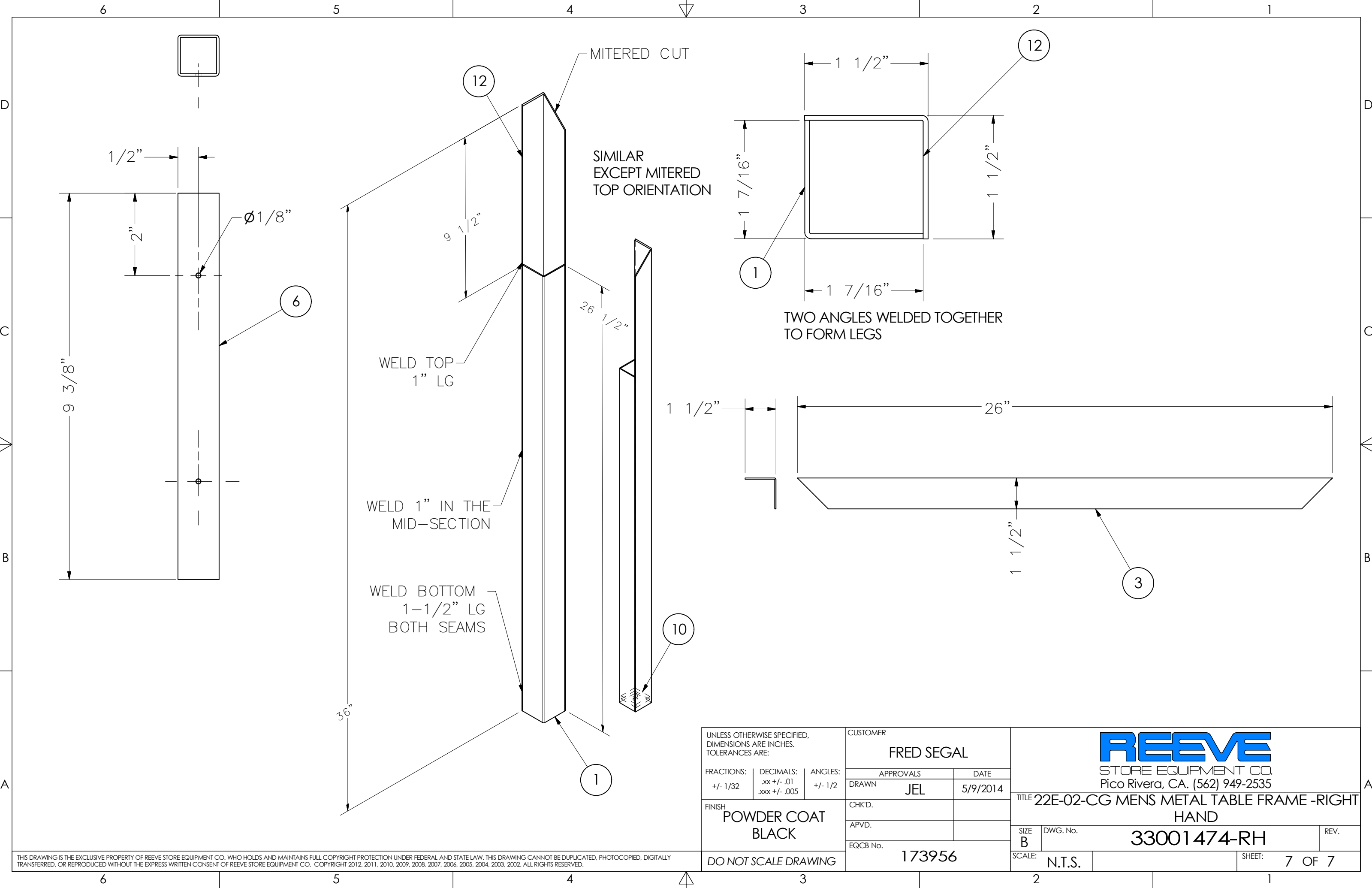

CLEAN TIG WELD

FLUSH WHEN ASSEMBLED ALL COMPONENTS

WELD ANGLES 1" LG IN THE MID-SECTION

STITCH WELD 1/2" LG

SEAMS NOT FULLY WELD

WELD 2 ANGLES 1-1/2" LONG BOTTOM SECTION

WELD AND BLEND-IN SEAMS

UNLESS OTHERWISE SPECIFIED, DIMENSIONS ARE INCHES. TOLERANCES ARE:

|            |                              |         |
|------------|------------------------------|---------|
| FRACTIONS: | DECIMALS:                    | ANGLES: |
| +/- 1/32   | .xx +/- .01<br>.xxx +/- .005 | +/- 1/2 |

FINISH  
POWDER COAT  
BLACK

DO NOT SCALE DRAWING

CUSTOMER

FRED SEGAL

|           |          |
|-----------|----------|
| APPROVALS | DATE     |
| DRAWN JEL | 5/9/2014 |

CHK'D.

APVD.

EQCB No.

**REEVE**

STORE EQUIPMENT CO.  
Pico Rivera, CA. (562) 949-2535

TITLE 22E-02-CG MENS METAL TABLE FRAME -RIGHT HAND

|        |             |      |
|--------|-------------|------|
| SIZE B | DWG. No.    | REV. |
|        | 33001474-RH |      |

|               |               |
|---------------|---------------|
| SCALE: N.T.S. | SHEET: 3 OF 7 |
|---------------|---------------|

THIS DRAWING IS THE EXCLUSIVE PROPERTY OF REEVE STORE EQUIPMENT CO. WHO HOLDS AND MAINTAINS FULL COPYRIGHT PROTECTION UNDER FEDERAL AND STATE LAW. THIS DRAWING CANNOT BE DUPLICATED, PHOTOCOPIED, DIGITALLY TRANSFERRED, OR REPRODUCED WITHOUT THE EXPRESS WRITTEN CONSENT OF REEVE STORE EQUIPMENT CO. COPYRIGHT 2012, 2011, 2010, 2009, 2008, 2007, 2006, 2005, 2004, 2003, 2002. ALL RIGHTS RESERVED.

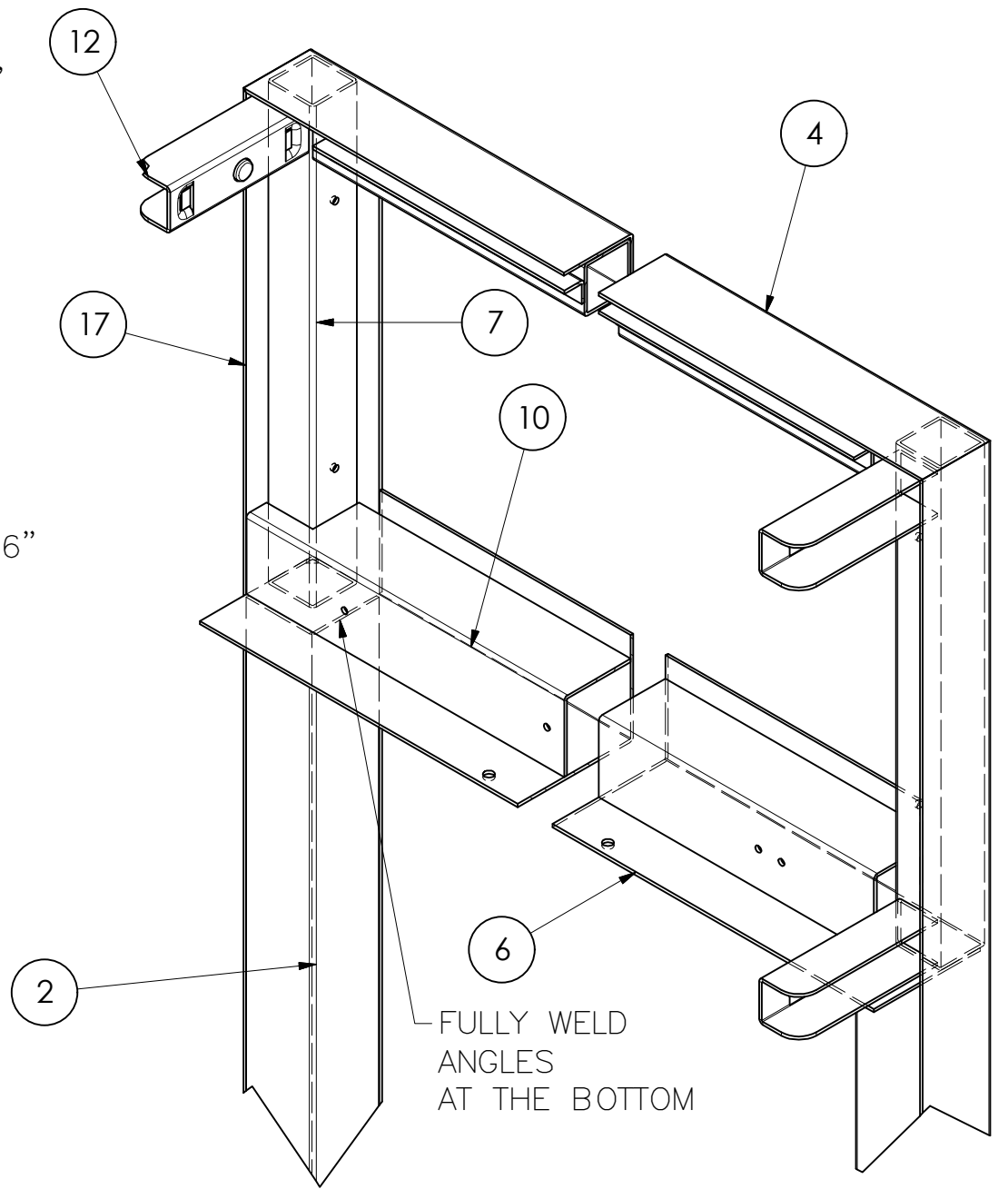
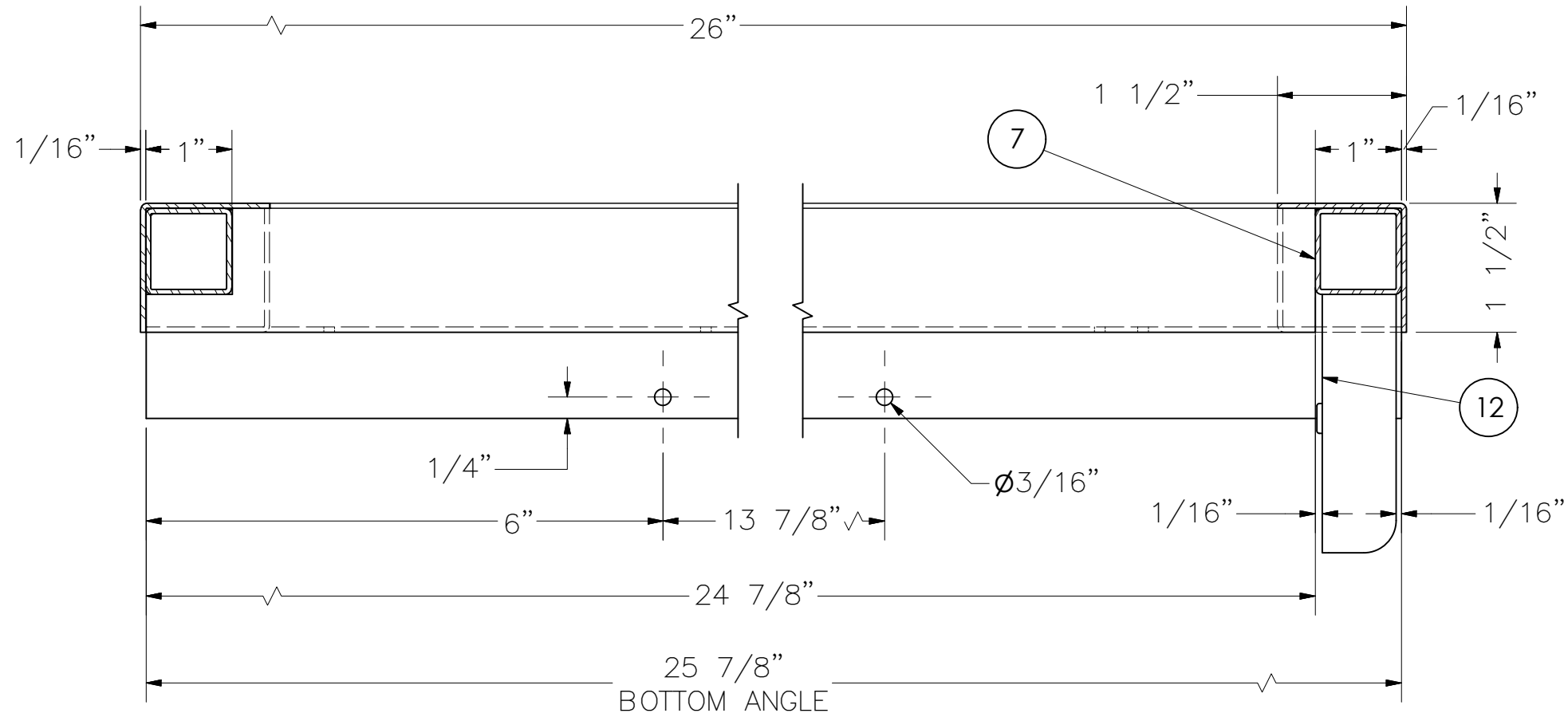

**SECTION B-B**

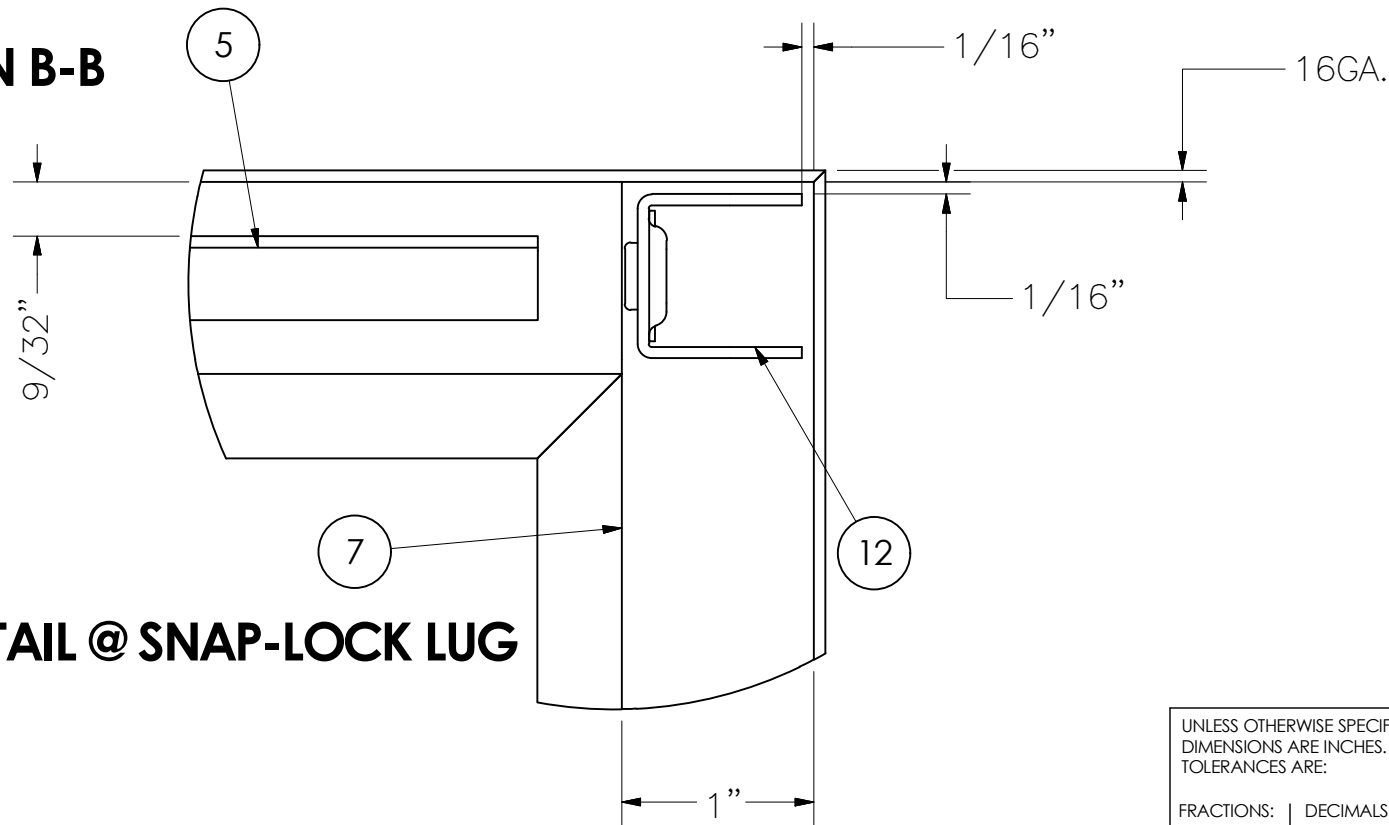

**DETAIL @ SNAP-LOCK LUG**

|  |   |                    |                               |          |
|--|---|--------------------|-------------------------------|----------|
| UNLESS OTHERWISE SPECIFIED, DIMENSIONS ARE INCHES. TOLERANCES ARE: |   |                    | CUSTOMER<br><b>FRED SEGAL</b> |          |
| FRACTIONS:<br>+/- 1/32   | DECIMALS:<br>.xx +/- .01<br>.xxx +/- .005 | ANGLES:<br>+/- 1/2 | APPROVALS                     | DATE     |
| FINISH<br><b>POWDER COAT BLACK</b>                                 |   |                    | DRAWN<br><b>JEL</b>           | 5/9/2014 |
| <b>DO NOT SCALE DRAWING</b>  |   |                    | CHK'D.                        |          |
|  |   |                    | APVD.                         |          |
|  |   |                    | EQCB No.                      |          |

|  |                                |      |
|--|--------------------------------|------|
| <b>REEVE</b><br>STORE EQUIPMENT CO.<br>Pico Rivera, CA. (562) 949-2535 |                                |      |
| TITLE <b>22E-02-CG MENS METAL TABLE FRAME -RIGHT HAND</b>              |                                |      |
| SIZE<br><b>B</b>   | DWG. No.<br><b>33001474-RH</b> | REV. |
| SCALE:<br><b>N.T.S.</b>  | SHEET:<br><b>4 OF 7</b>        |      |

6 5 4 3 2 1

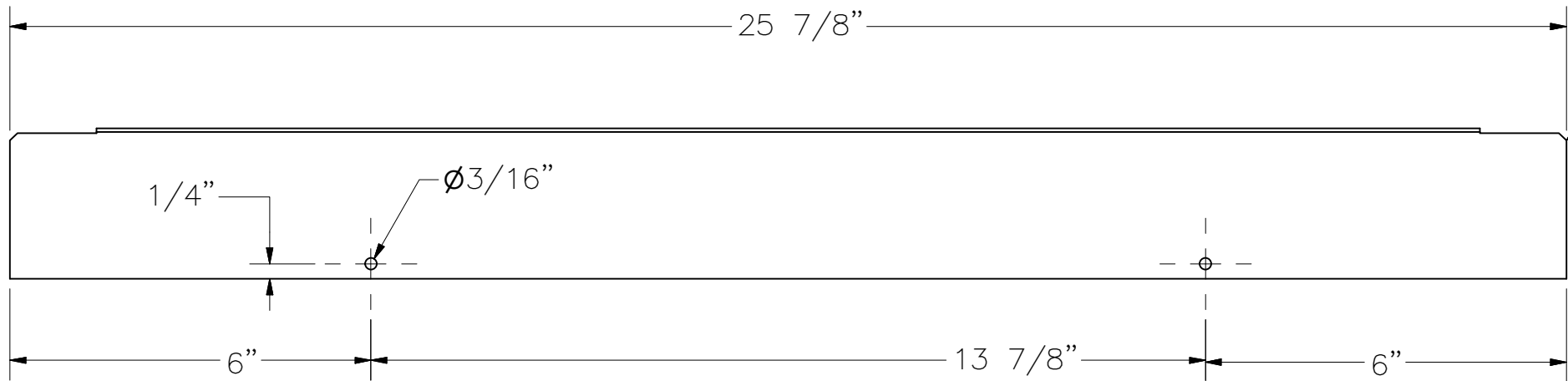

EASE THIS CORNER FOR INSIDE RADIUS ON UPRIGHT ANGLE (2X)

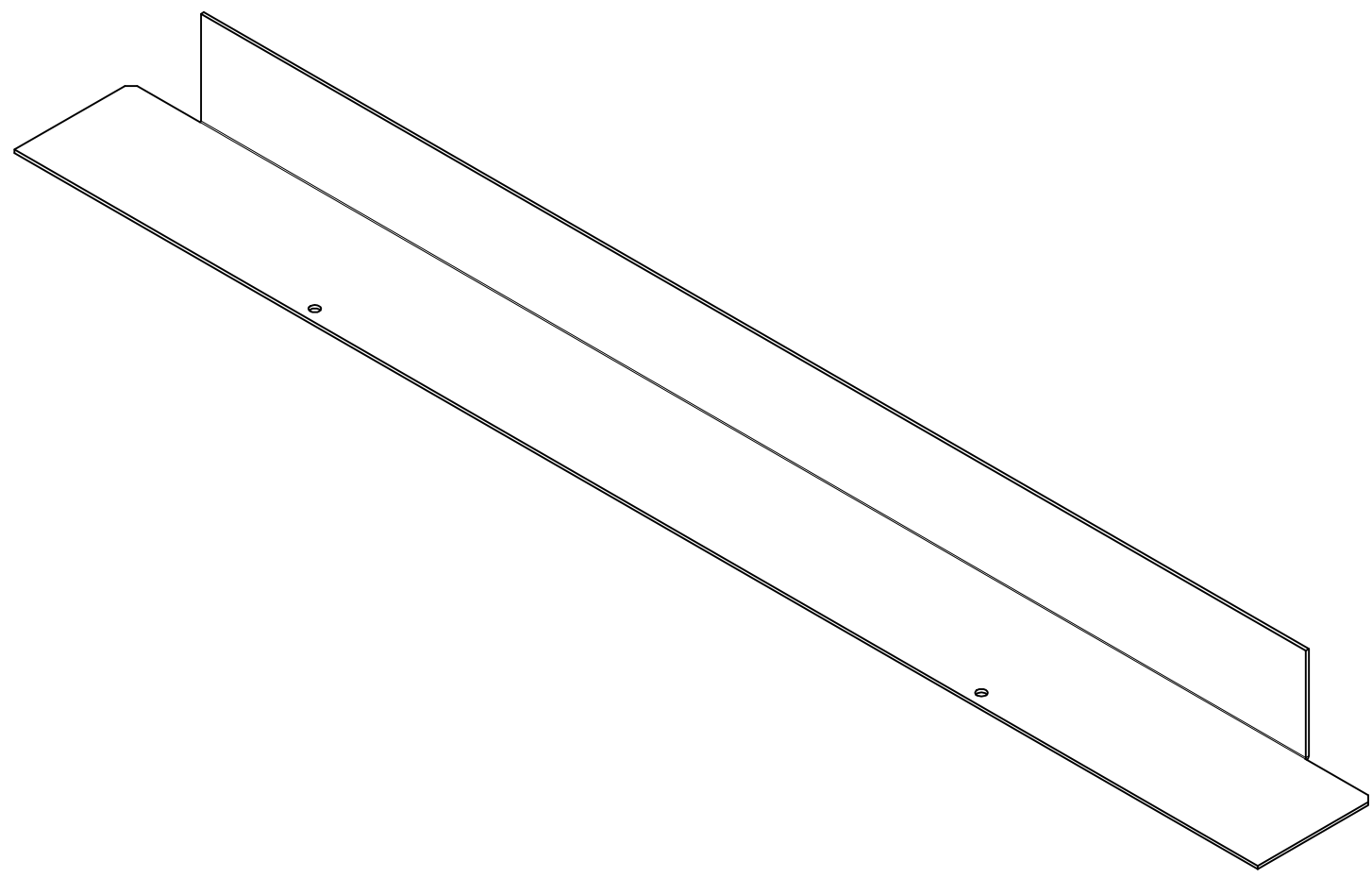
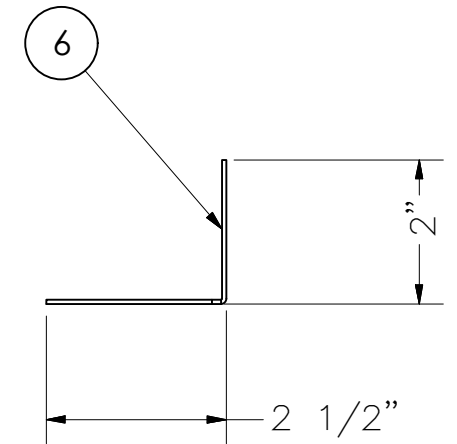
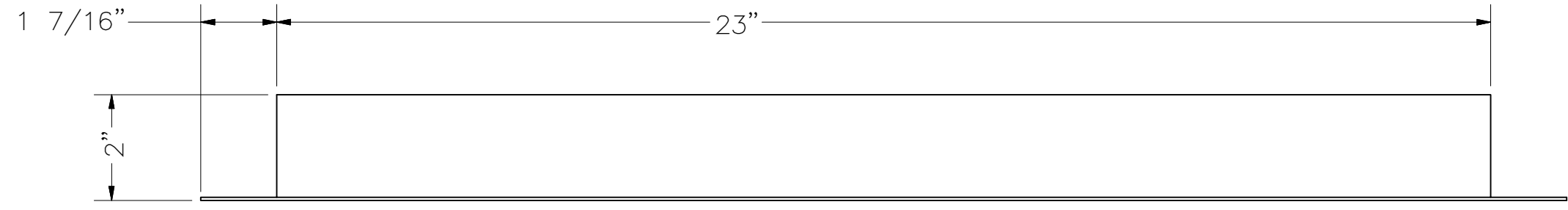

▽

B

A

|  |   |                    |                               |          |  |
|--|---|--------------------|-------------------------------|----------|--|
| UNLESS OTHERWISE SPECIFIED, DIMENSIONS ARE INCHES. TOLERANCES ARE: |   |                    | CUSTOMER<br><b>FRED SEGAL</b> |          | <br>STORE EQUIPMENT CO.<br>Pico Rivera, CA. (562) 949-2535   |
| FRACTIONS:<br>+/- 1/32   | DECIMALS:<br>.xx +/- .01<br>.xxx +/- .005 | ANGLES:<br>+/- 1/2 | APPROVALS                     | DATE     |  |
| FINISH<br><b>POWDER COAT BLACK</b>                                 |   |                    | DRAWN<br><b>JEL</b>           | 5/9/2014 | TITLE<br><b>22E-02-CG MENS METAL TABLE FRAME -RIGHT HAND</b> |
| DO NOT SCALE DRAWING   |   |                    | CHK'D.                        |          | SIZE<br><b>B</b>   |
|  |   |                    | APVD.                         |          | DWG. No.<br><b>33001474-RH</b>                               |
|  |   |                    | EQCB No.                      |          | REV.   |
|  |   |                    | SCALE:<br><b>N.T.S.</b>       |          | SHEET:<br><b>5 OF 7</b>                                      |

THIS DRAWING IS THE EXCLUSIVE PROPERTY OF REEVE STORE EQUIPMENT CO. WHO HOLDS AND MAINTAINS FULL COPYRIGHT PROTECTION UNDER FEDERAL AND STATE LAW. THIS DRAWING CANNOT BE DUPLICATED, PHOTOCOPIED, DIGITALLY TRANSFERRED, OR REPRODUCED WITHOUT THE EXPRESS WRITTEN CONSENT OF REEVE STORE EQUIPMENT CO. COPYRIGHT 2012, 2011, 2010, 2009, 2008, 2007, 2006, 2005, 2004, 2003, 2002. ALL RIGHTS RESERVED.

6 5 4 3 2 1

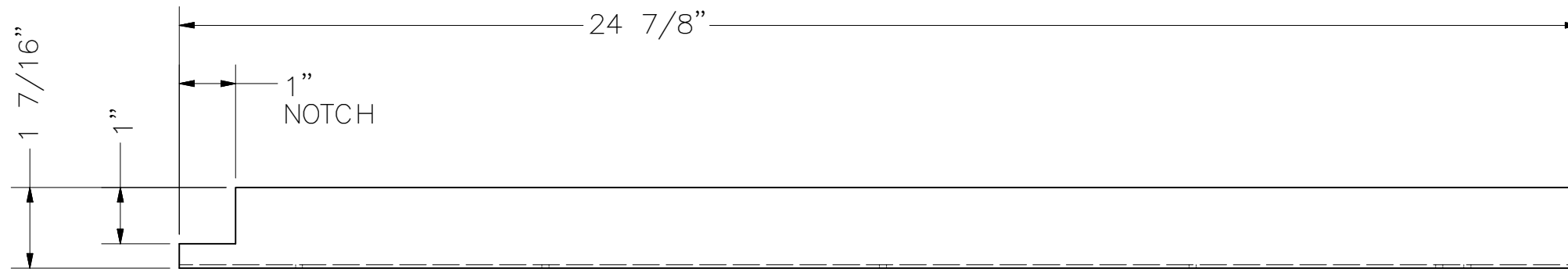

Ø1/8"  
PILOT HOLES FOR  
SIDE MOUNT DRAWER SLIDE  
FROM McMASTER CARR #63835A360

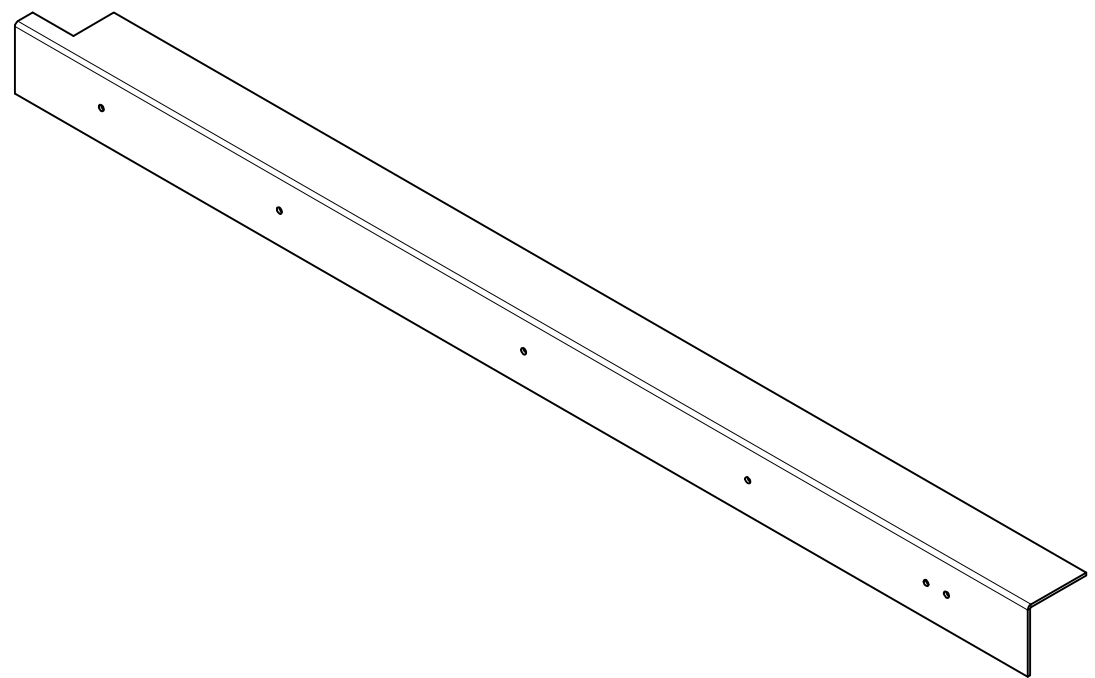
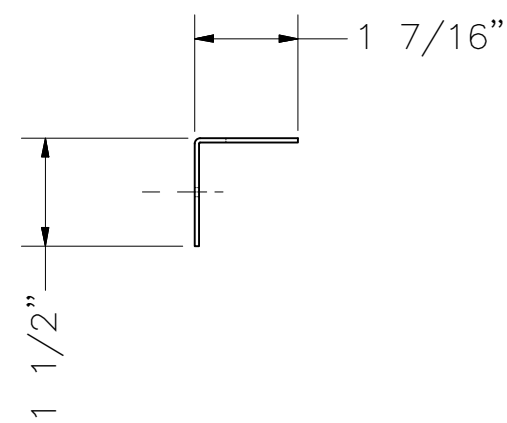
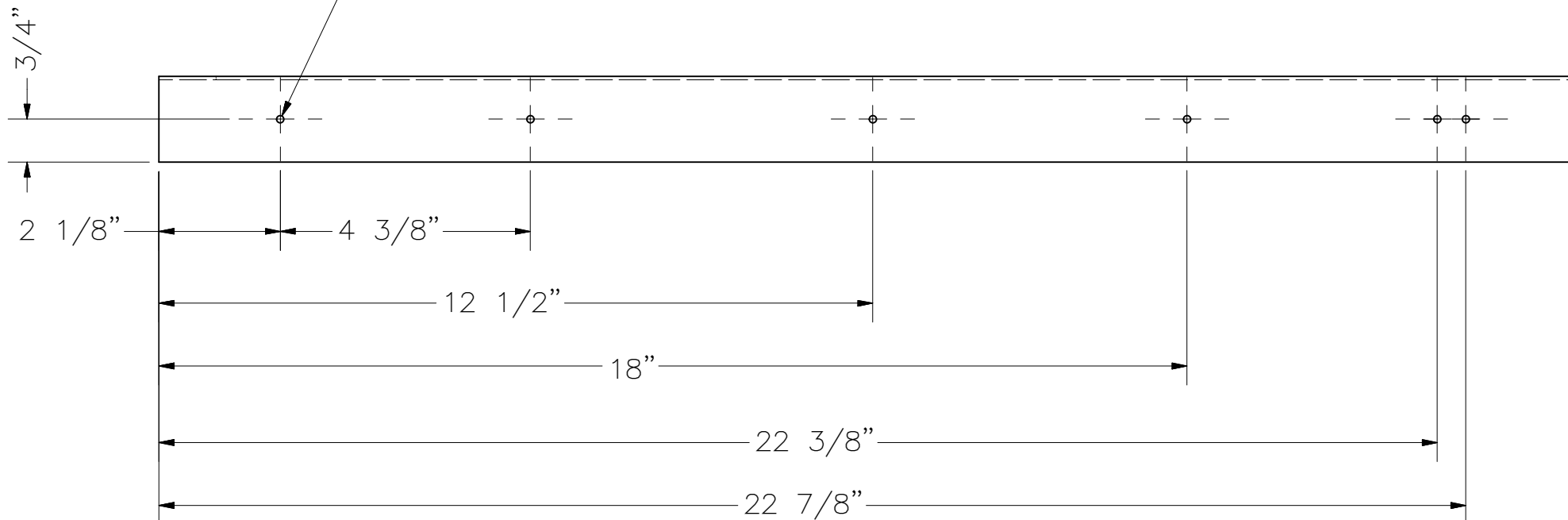

UNLESS OTHERWISE SPECIFIED,  
DIMENSIONS ARE INCHES.  
TOLERANCES ARE:

|                        |   |                    |
|------------------------|---|--------------------|
| FRACTIONS:<br>+/- 1/32 | DECIMALS:<br>.xx +/- .01<br>.xxx +/- .005 | ANGLES:<br>+/- 1/2 |
|------------------------|---|--------------------|

FINISH  
**POWDER COAT  
BLACK**

**DO NOT SCALE DRAWING**

CUSTOMER  
**FRED SEGAL**

|                  |          |
|------------------|----------|
| APPROVALS        | DATE     |
| DRAWN <b>JEL</b> | 5/9/2014 |

|          |  |
|----------|--|
| CHK'D.   |  |
| APVD.    |  |
| EQCB No. |  |

**REEVE**

STORE EQUIPMENT CO.  
Pico Rivera, CA. (562) 949-2535

TITLE **22E-02-CG MENS METAL TABLE FRAME -RIGHT  
HAND**

|                  |                                |      |
|------------------|--------------------------------|------|
| SIZE<br><b>B</b> | DWG. No.<br><b>33001474-RH</b> | REV. |
|------------------|--------------------------------|------|

|                         |                         |
|-------------------------|-------------------------|
| SCALE:<br><b>N.T.S.</b> | SHEET:<br><b>6 OF 7</b> |
|-------------------------|-------------------------|

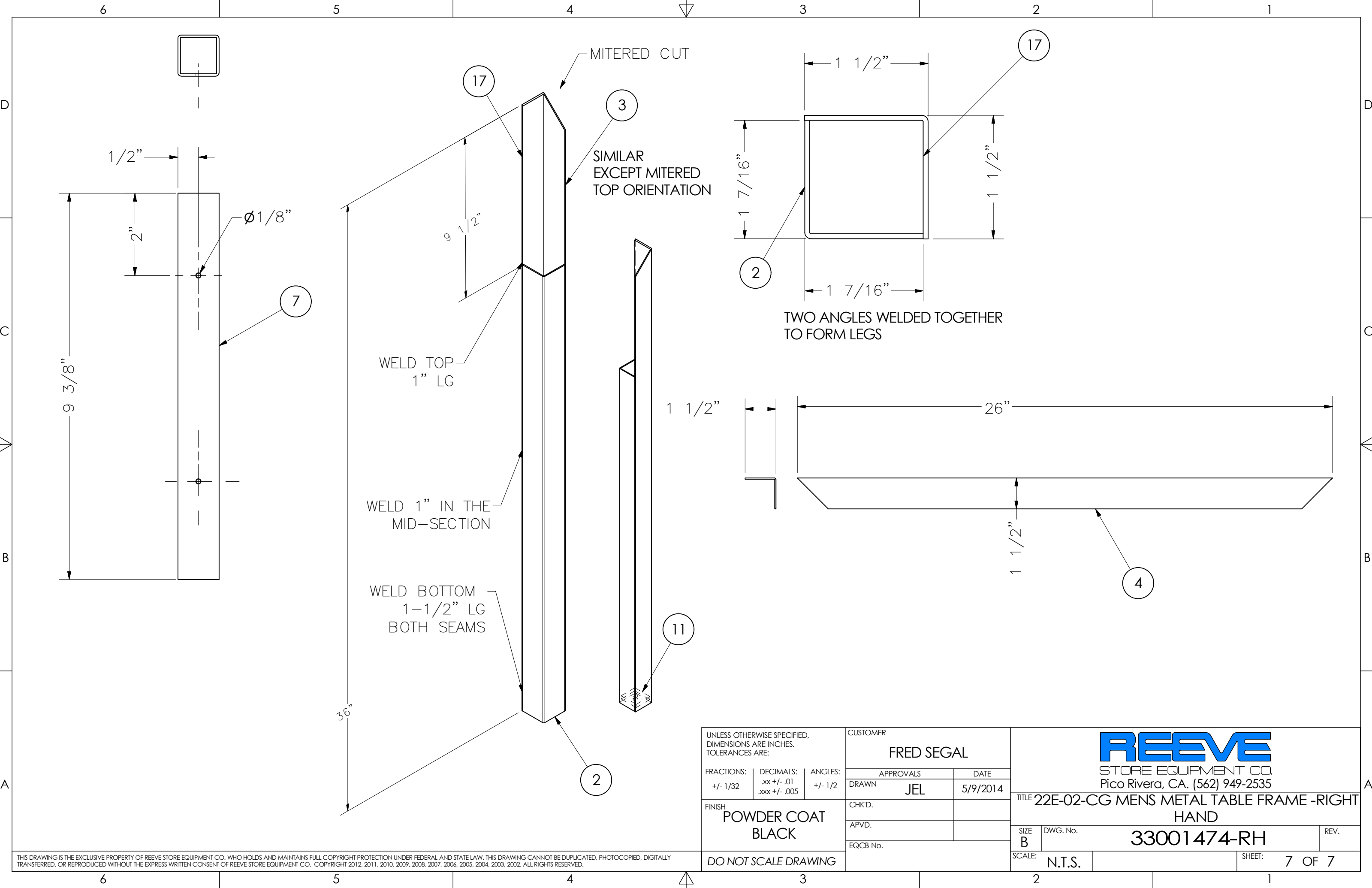

UNLESS OTHERWISE SPECIFIED,  
DIMENSIONS ARE INCHES.  
TOLERANCES ARE:

|                        |   |                    |
|------------------------|---|--------------------|
| FRACTIONS:<br>+/- 1/32 | DECIMALS:<br>.xx +/- .01<br>.xxx +/- .005 | ANGLES:<br>+/- 1/2 |
|------------------------|---|--------------------|

FINISH  
**POWDER COAT  
BLACK**

DO NOT SCALE DRAWING

CUSTOMER  
**FRED SEGAL**

|                  |          |
|------------------|----------|
| APPROVALS        | DATE     |
| DRAWN <b>JEL</b> | 5/9/2014 |

|          |  |
|----------|--|
| CHK'D.   |  |
| APVD.    |  |
| EQCB No. |  |

**REEVE**

STORE EQUIPMENT CO.  
Pico Rivera, CA. (562) 949-2535

TITLE **22E-02-CG MENS METAL TABLE FRAME -RIGHT  
HAND**

|                  |                                |      |
|------------------|--------------------------------|------|
| SIZE<br><b>B</b> | DWG. No.<br><b>33001474-RH</b> | REV. |
|------------------|--------------------------------|------|

|                         |                         |
|-------------------------|-------------------------|
| SCALE:<br><b>N.T.S.</b> | SHEET:<br><b>7 OF 7</b> |
|-------------------------|-------------------------|



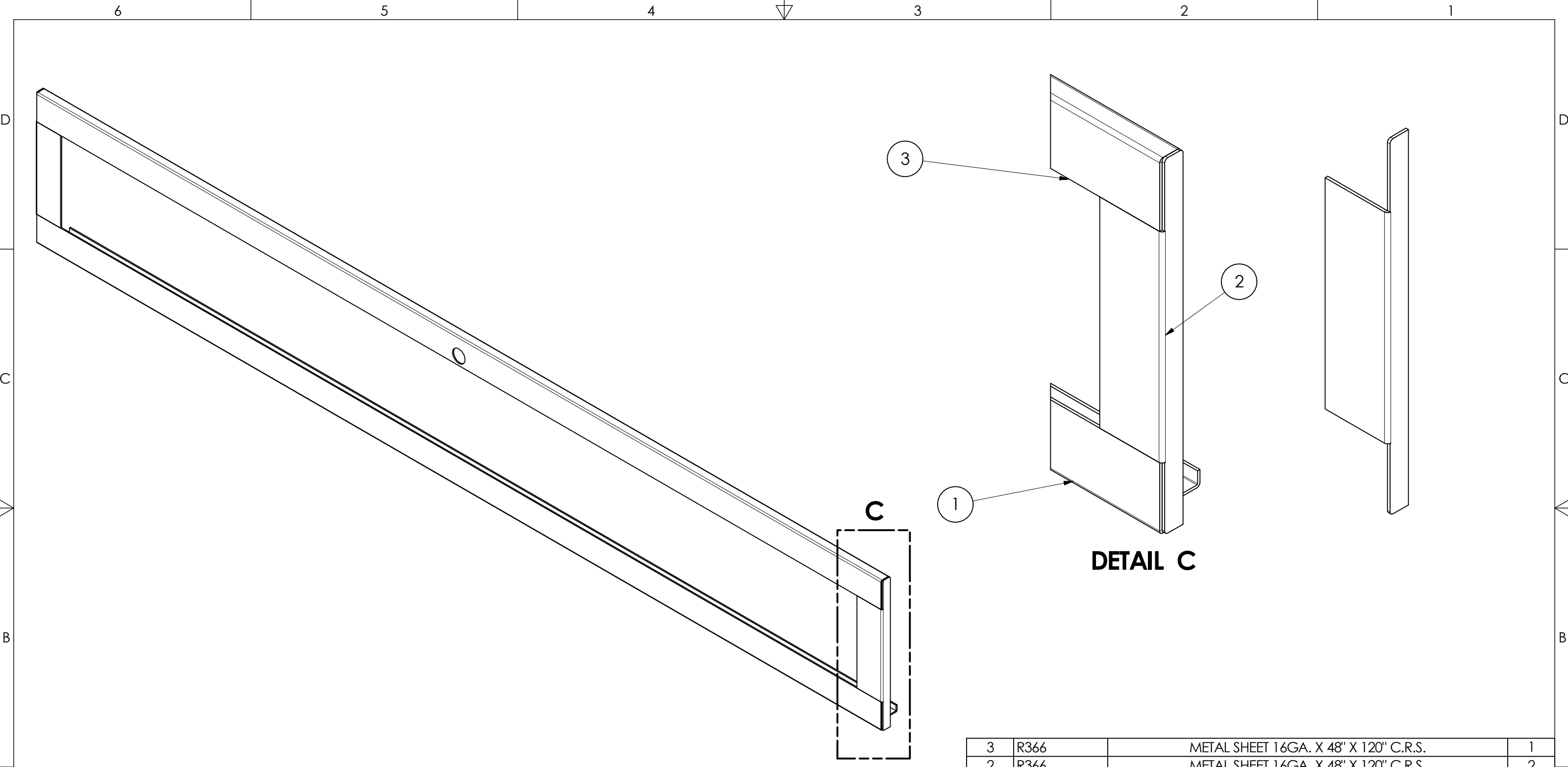

| ITEM | PART No. | DESCRIPTION                           | QTY. |
|------|----------|---------------------------------------|------|
| 3    | R366     | METAL SHEET 16GA. X 48" X 120" C.R.S. | 1    |
| 2    | R366     | METAL SHEET 16GA. X 48" X 120" C.R.S. | 2    |
| 1    | R366     | METAL SHEET 16GA. X 48" X 120" C.R.S. | 1    |

**BILL OF MATERIALS**

|  |   |                               |                     |  |  |
|--|---|-------------------------------|---------------------|--|--|
| UNLESS OTHERWISE SPECIFIED, DIMENSIONS ARE INCHES. TOLERANCES ARE: |   | CUSTOMER<br><b>FRED SEGAL</b> |                     | <br>STORE EQUIPMENT CO.<br>Pico Rivera, CA. (562) 949-2535 |  |
| FRACTIONS:<br>+/- 1/32   | DECIMALS:<br>.xx +/- .01<br>.xxx +/- .005 | ANGLES:<br>+/- 1/2            | APPROVALS           |  |  |
| FINISH<br><b>POWDER COAT<br/>BLACK</b>                             |   |                               | DRAWN<br><b>JEL</b> | 5/9/2014   | TITLE<br><b>22E-02-CG MENS DISPLAY CASE METAL<br/>DRAWER FRONT FRAME</b> |
| <b>DO NOT SCALE DRAWING</b>  |   |                               | CHK'D.              |  | SIZE<br><b>B</b>   |
|  |   |                               | APVD.               |  | DWG. No.<br><b>33001475</b>  |
|  |   |                               | EQCB No.            |  | SCALE:<br><b>N.T.S.</b>  |
|  |   |                               |                     |  | SHEET:<br><b>1 OF 3</b>  |

THIS DRAWING IS THE EXCLUSIVE PROPERTY OF REEVE STORE EQUIPMENT CO. WHO HOLDS AND MAINTAINS FULL COPYRIGHT PROTECTION UNDER FEDERAL AND STATE LAW. THIS DRAWING CANNOT BE DUPLICATED, PHOTOCOPIED, DIGITALLY TRANSFERRED, OR REPRODUCED WITHOUT THE EXPRESS WRITTEN CONSENT OF REEVE STORE EQUIPMENT CO. COPYRIGHT 2012, 2011, 2010, 2009, 2008, 2007, 2006, 2005, 2004, 2003, 2002. ALL RIGHTS RESERVED.

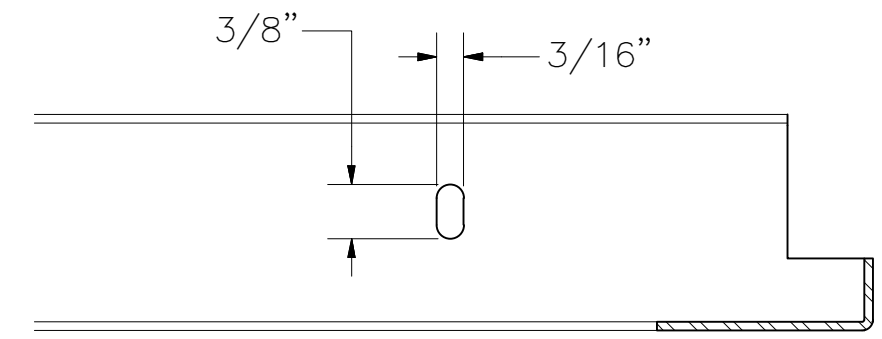
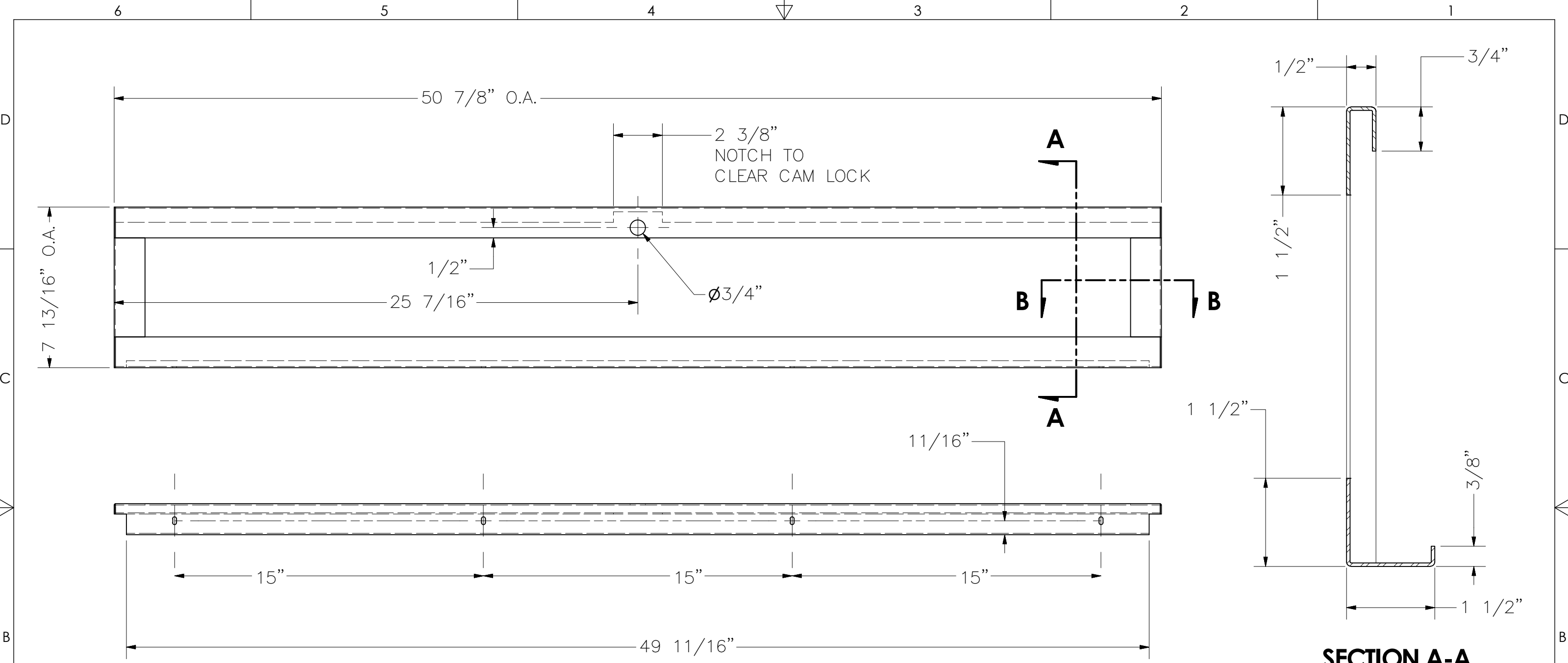

**SECTION B-B**

|  |   |                    |                               |          |
|--|---|--------------------|-------------------------------|----------|
| UNLESS OTHERWISE SPECIFIED, DIMENSIONS ARE INCHES. TOLERANCES ARE: |   |                    | CUSTOMER<br><b>FRED SEGAL</b> |          |
| FRACTIONS:<br>+/- 1/32   | DECIMALS:<br>.xx +/- .01<br>.xxx +/- .005 | ANGLES:<br>+/- 1/2 | APPROVALS                     | DATE     |
| FINISH<br><b>POWDER COAT BLACK</b>                                 |   |                    | DRAWN<br><b>JEL</b>           | 5/9/2014 |
| <b>DO NOT SCALE DRAWING</b>  |   |                    | CHK'D.                        |          |
|  |   |                    | APVD.                         |          |
|  |   |                    | EQCB No.                      |          |

|                                     |  |        |                  |   |                 |
|-------------------------------------|--|--------|------------------|---|-----------------|
| <br>Pico Rivera, CA. (562) 949-2535 |  |        | TITLE            | <b>22E-02-CG MENS DISPLAY CASE METAL DRAWER FRONT FRAME</b> |                 |
|                                     |  |        | SIZE<br><b>B</b> | DWG. No.  | <b>33001475</b> |
| SCALE:<br><b>N.T.S.</b>             |  | SHEET: |                  | <b>2 OF 3</b>   |                 |

THIS DRAWING IS THE EXCLUSIVE PROPERTY OF REEVE STORE EQUIPMENT CO. WHO HOLDS AND MAINTAINS FULL COPYRIGHT PROTECTION UNDER FEDERAL AND STATE LAW. THIS DRAWING CANNOT BE DUPLICATED, PHOTOCOPIED, DIGITALLY TRANSFERRED, OR REPRODUCED WITHOUT THE EXPRESS WRITTEN CONSENT OF REEVE STORE EQUIPMENT CO. COPYRIGHT 2012, 2011, 2010, 2009, 2008, 2007, 2006, 2005, 2004, 2003, 2002. ALL RIGHTS RESERVED.

6

5

4

3

2

1

D

D

C

C

B

B

A

A

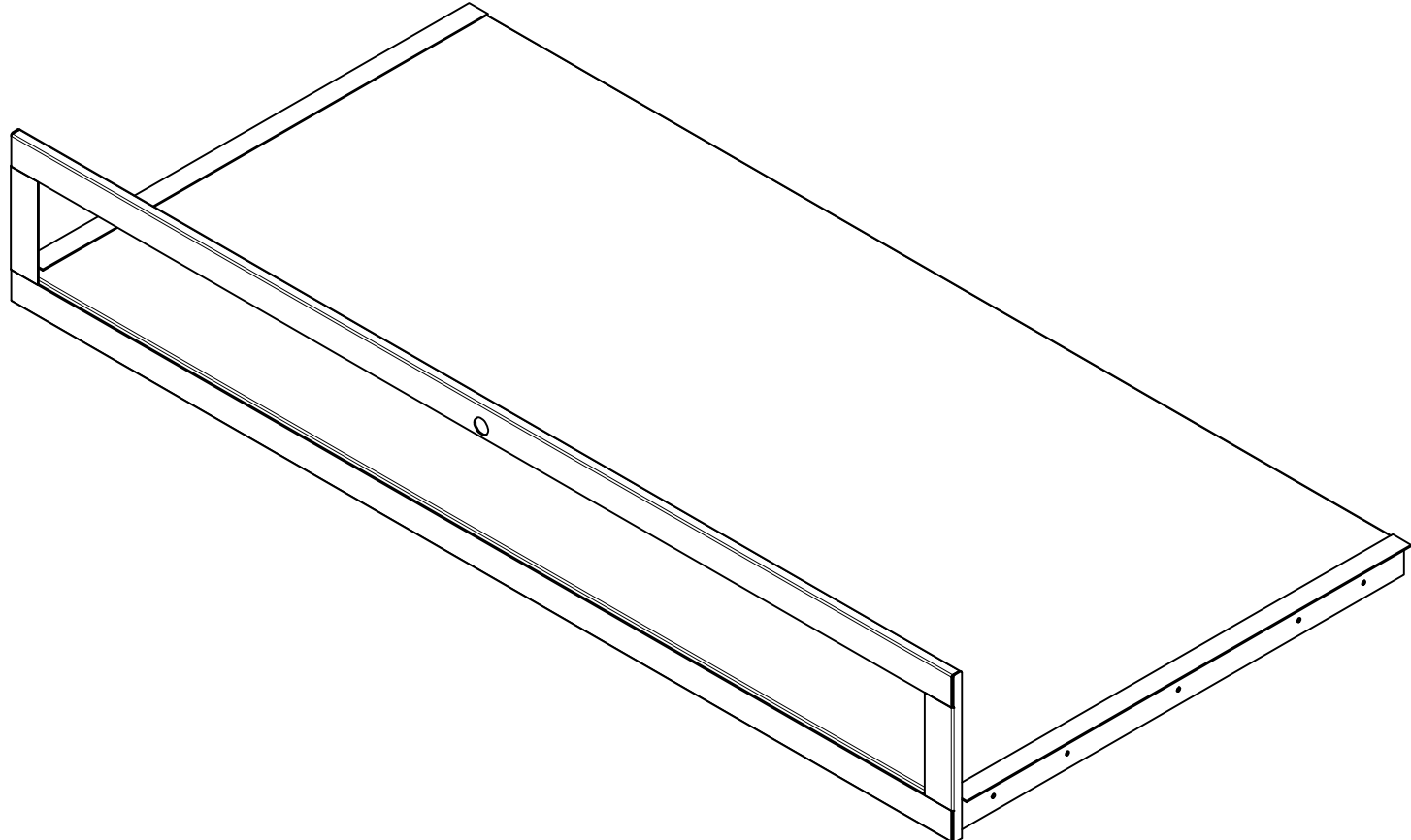
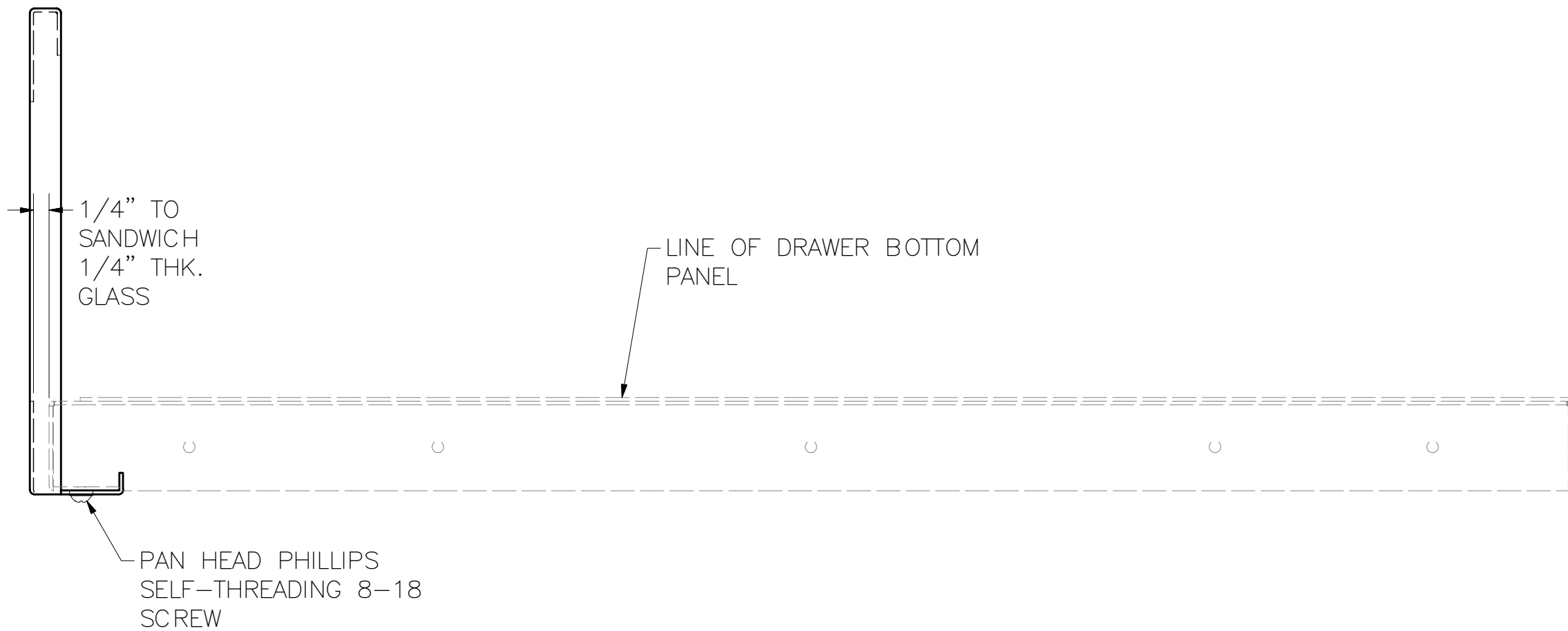

UNLESS OTHERWISE SPECIFIED,  
DIMENSIONS ARE INCHES.  
TOLERANCES ARE:

|  |   |                    |
|--|---|--------------------|
| FRACTIONS:<br>+/- 1/32                 | DECIMALS:<br>.xx +/- .01<br>.xxx +/- .005 | ANGLES:<br>+/- 1/2 |
| FINISH<br><b>POWDER COAT<br/>BLACK</b> |   |                    |
| <b>DO NOT SCALE DRAWING</b>            |   |                    |

|                               |          |
|-------------------------------|----------|
| CUSTOMER<br><b>FRED SEGAL</b> |          |
| APPROVALS                     | DATE     |
| DRAWN<br><b>JEL</b>           | 5/9/2014 |
| CHK'D.                        |          |
| APVD.                         |          |
| EQCB No.                      |          |

|   |                             |      |
|---|-----------------------------|------|
| <br>STORE EQUIPMENT CO.<br>Pico Rivera, CA. (562) 949-2535 |                             |      |
| TITLE<br><b>22E-02-CG MENS DISPLAY CASE METAL<br/>DRAWER FRONT FRAME</b>  |                             |      |
| SIZE<br><b>B</b>  | DWG. No.<br><b>33001475</b> | REV. |
| SCALE:<br><b>N.T.S.</b>   | SHEET:<br><b>3 OF 3</b>     |      |

THIS DRAWING IS THE EXCLUSIVE PROPERTY OF REEVE STORE EQUIPMENT CO. WHO HOLDS AND MAINTAINS FULL COPYRIGHT PROTECTION UNDER FEDERAL AND STATE LAW. THIS DRAWING CANNOT BE DUPLICATED, PHOTOCOPIED, DIGITALLY TRANSFERRED, OR REPRODUCED WITHOUT THE EXPRESS WRITTEN CONSENT OF REEVE STORE EQUIPMENT CO. COPYRIGHT 2012, 2011, 2010, 2009, 2008, 2007, 2006, 2005, 2004, 2003, 2002. ALL RIGHTS RESERVED.

6

5

4

3

2

1

6 5 4 3 2 1

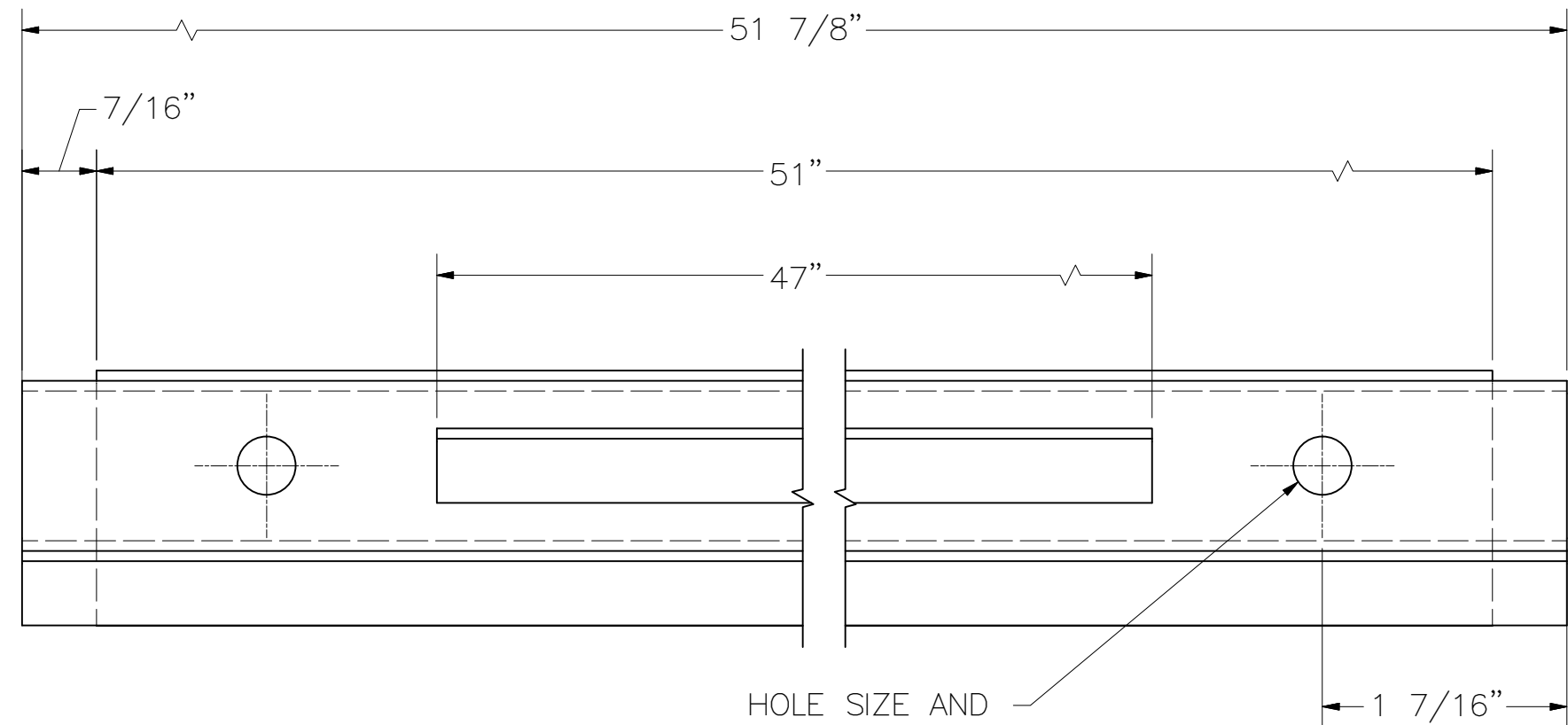

HOLE SIZE AND LOCATION MUST MATCH SNAP-LOCK LUG

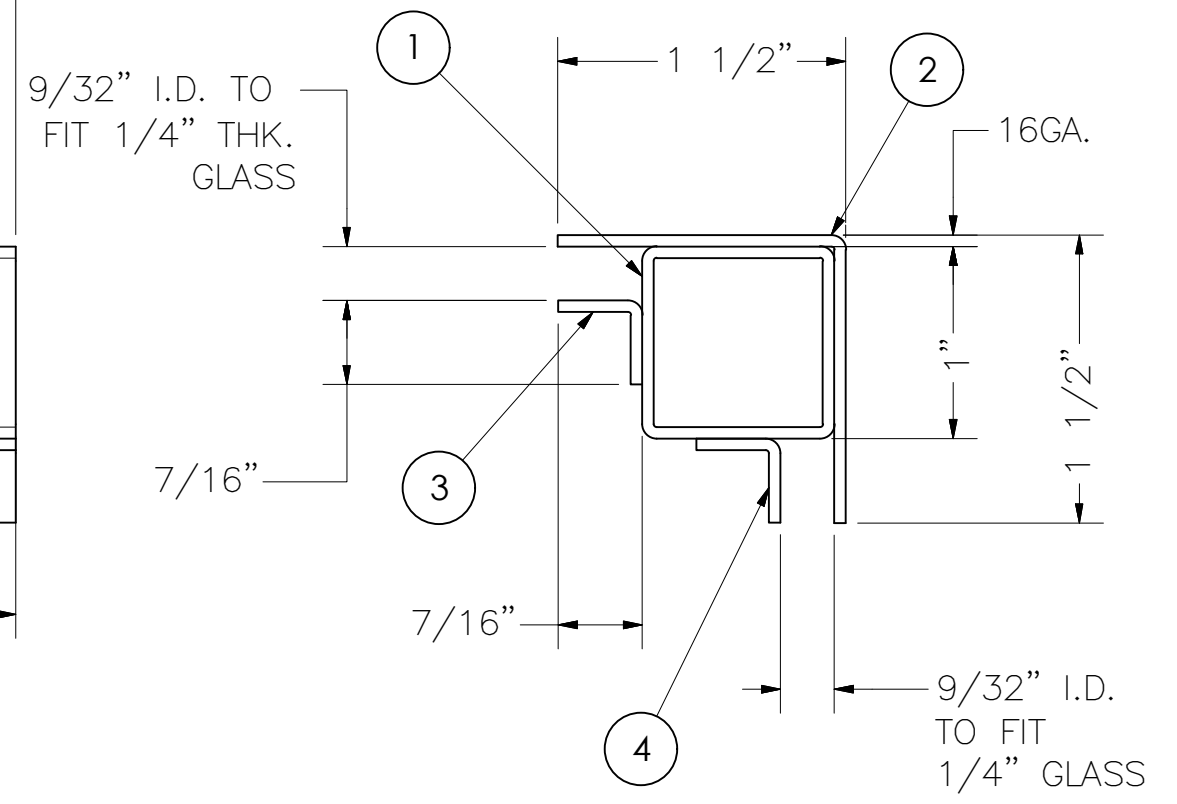
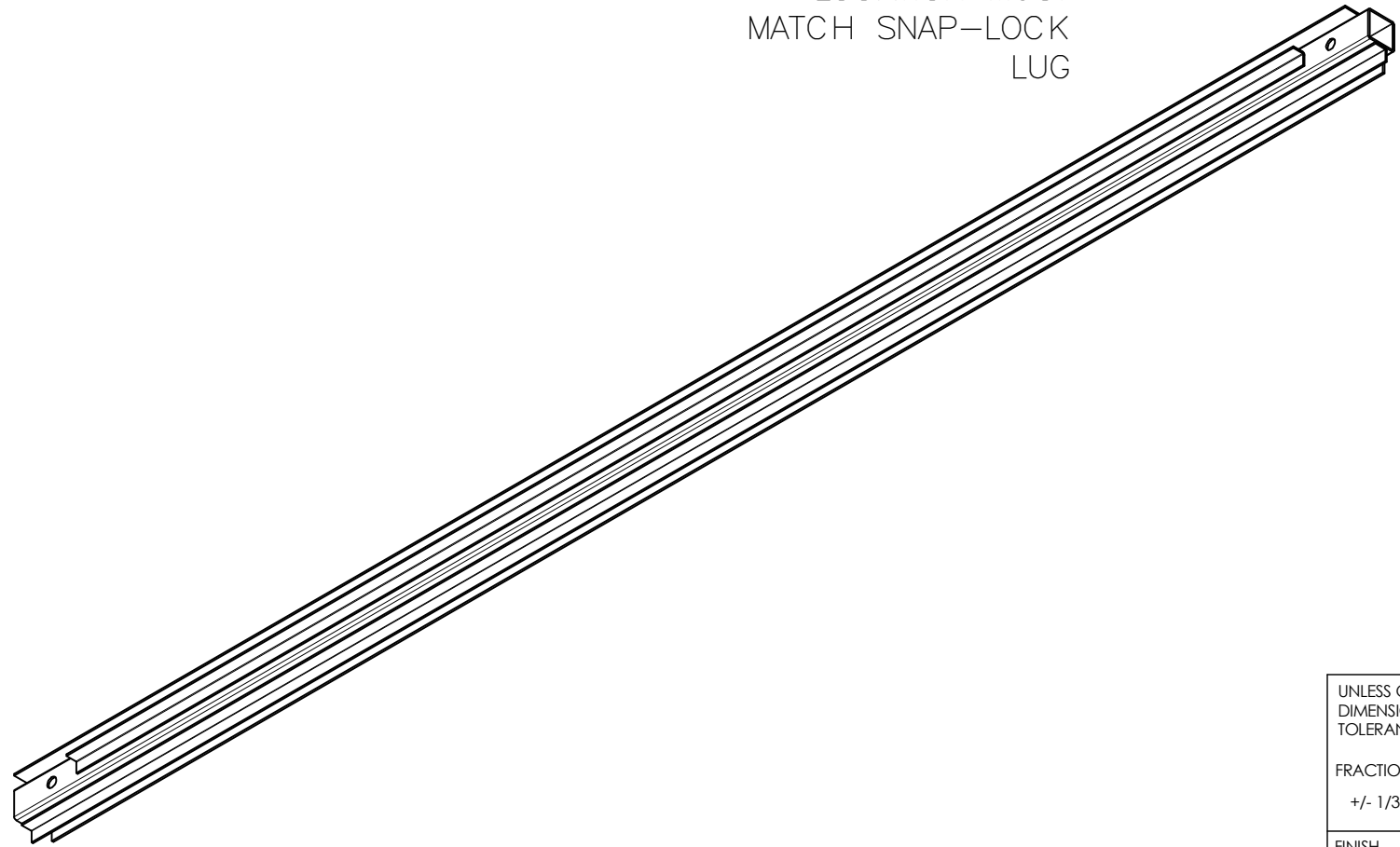

| ITEM | PART No. | DESCRIPTION                           | QTY. |
|------|----------|---------------------------------------|------|
| 4    | R366     | METAL SHEET 16GA. X 48" X 120" C.R.S. | 1    |
| 3    | R366     | METAL SHEET 16GA. X 48" X 120" C.R.S. | 1    |
| 2    | R366     | METAL SHEET 16GA. X 48" X 120" C.R.S. | 1    |
| 1    | R70      | .060 x 1.00 SQ x 290 C.R. TUBE (85)   | 1    |

BILL OF MATERIALS

|  |   |                    |
|--|---|--------------------|
| UNLESS OTHERWISE SPECIFIED, DIMENSIONS ARE INCHES. TOLERANCES ARE: |   |                    |
| FRACTIONS:<br>+/- 1/32   | DECIMALS:<br>.xx +/- .01<br>.xxx +/- .005 | ANGLES:<br>+/- 1/2 |
| FINISH<br><b>POWDER COAT BLACK</b>                                 |   |                    |
| <b>DO NOT SCALE DRAWING</b>  |   |                    |

|                               |          |
|-------------------------------|----------|
| CUSTOMER<br><b>FRED SEGAL</b> |          |
| APPROVALS                     | DATE     |
| DRAWN<br><b>JEL</b>           | 5/9/2014 |
| CHK'D.                        |          |
| APVD.                         |          |
| EQCB No.                      |          |

**REEVE**  
STORE EQUIPMENT CO.  
Pico Rivera, CA. (562) 949-2535

TITLE: **22E-02-CG MENS DISPLAY CASE METAL TOP GASS STRETCHER**

SIZE B DWG. No. **33001476** REV.

SCALE: **N.T.S.** SHEET: **1 OF 1**

6 5 4 3 2 1

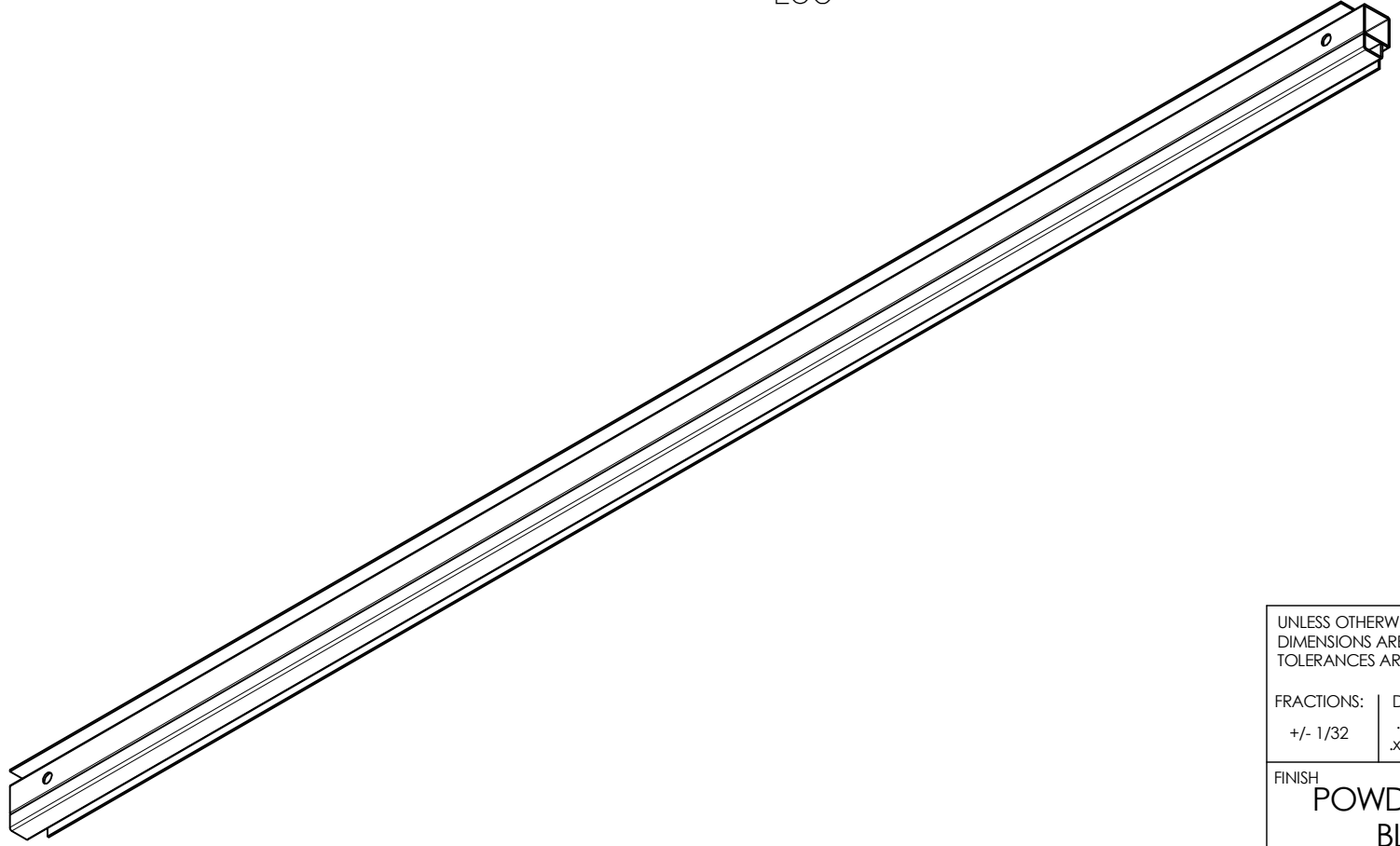
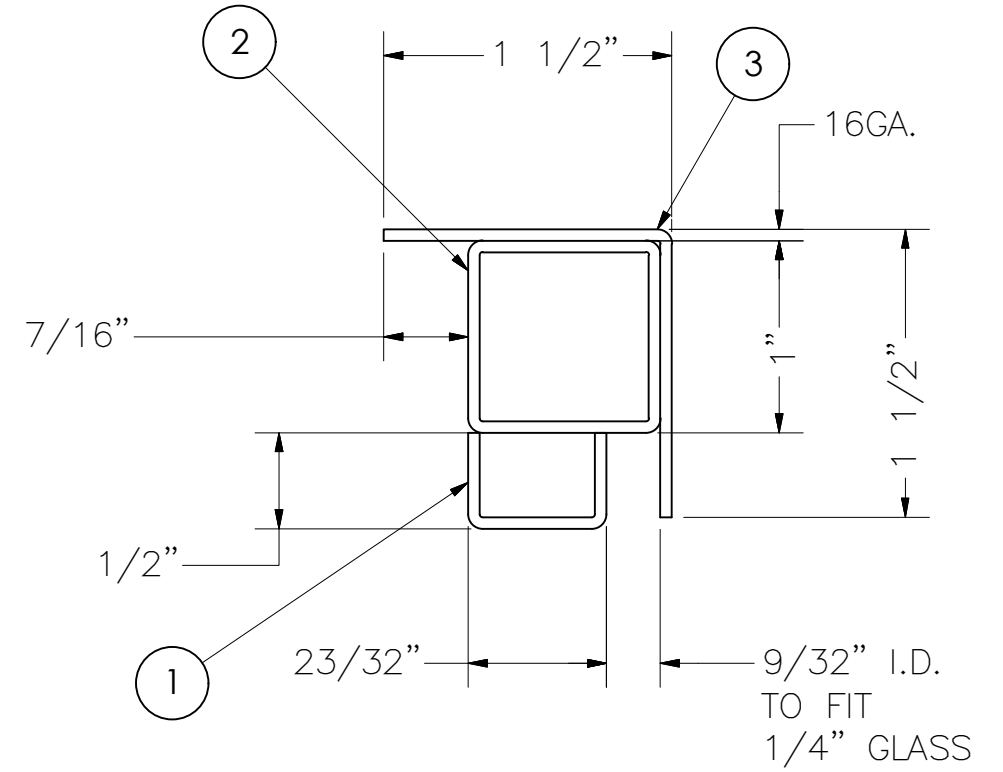
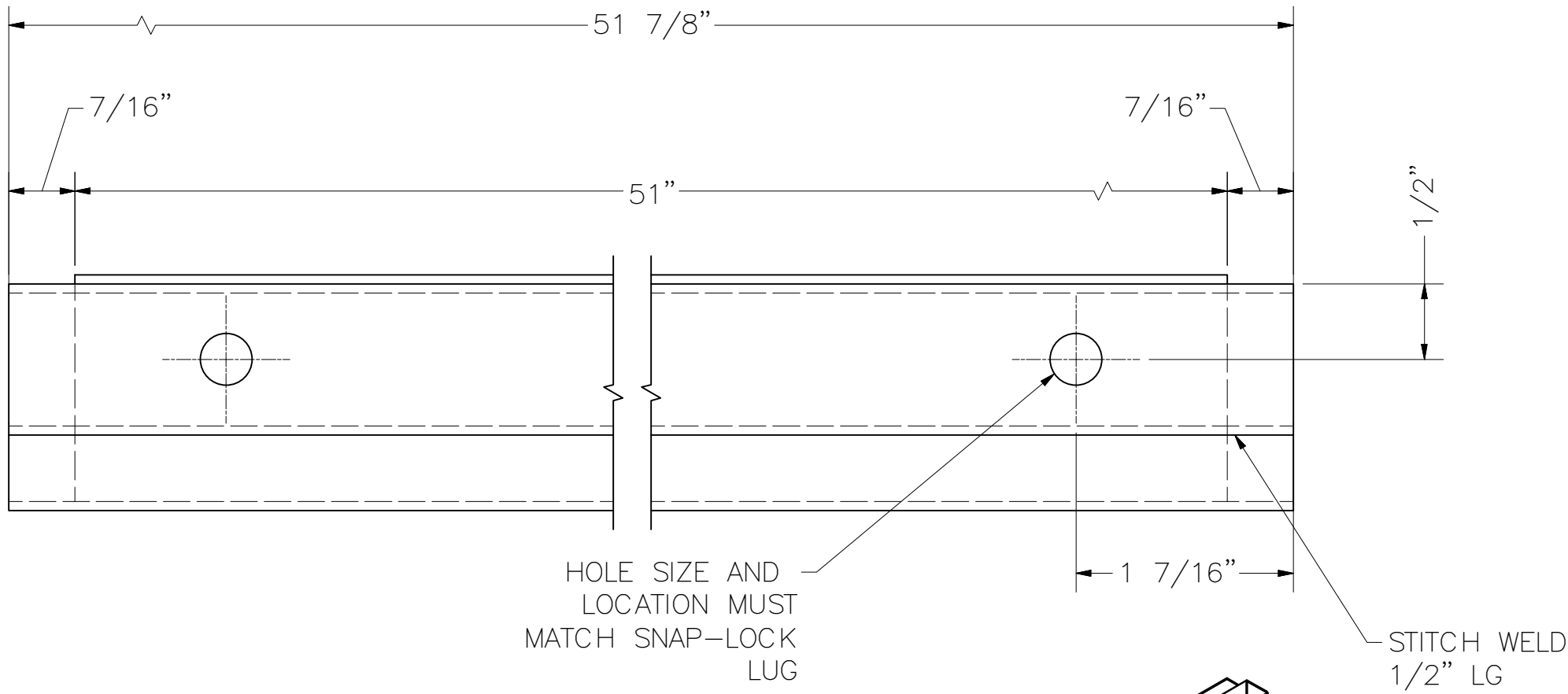

| ITEM | PART No. | DESCRIPTION                           | QTY. |
|------|----------|---------------------------------------|------|
| 1    | R366     | METAL SHEET 16GA. X 48" X 120" C.R.S. | 1    |
| 3    | R366     | METAL SHEET 16GA. X 48" X 120" C.R.S. | 1    |
| 2    | R70      | .060 x 1.00 SQ x 290 C.R. TUBE (85)   | 1    |

BILL OF MATERIALS

|  |   |                    |            |
|--|---|--------------------|------------|
| UNLESS OTHERWISE SPECIFIED, DIMENSIONS ARE INCHES. TOLERANCES ARE: |   | CUSTOMER           |            |
| FRACTIONS:<br>+/- 1/32   | DECIMALS:<br>.xx +/- .01<br>.xxx +/- .005 | ANGLES:<br>+/- 1/2 | FRED SEGAL |
| FINISH<br>POWDER COAT<br>BLACK                                     |   | APPROVALS          | DATE       |
| DO NOT SCALE DRAWING   |   | DRAWN<br>JEL       | 5/9/2014   |
|  |   | CHK'D.             |            |
|  |   | APVD.              |            |
|  |   | EQCB No.           |            |

|  |          |   |        |
|--|----------|---|--------|
| <br>STORE EQUIPMENT CO.<br>Pico Rivera, CA. (562) 949-2535 |          | TITLE   |        |
|  |          | 22E-02-CG MENS DISPLAY CASE METAL<br>BOTTOM GLASS STRETCHER |        |
| SIZE<br>B  | DWG. No. | REV.  |        |
| SCALE:<br>N.T.S.   | 33001477 | SHEET:  | 1 OF 1 |

THIS DRAWING IS THE EXCLUSIVE PROPERTY OF REEVE STORE EQUIPMENT CO. WHO HOLDS AND MAINTAINS FULL COPYRIGHT PROTECTION UNDER FEDERAL AND STATE LAW. THIS DRAWING CANNOT BE DUPLICATED, PHOTOCOPIED, DIGITALLY TRANSFERRED, OR REPRODUCED WITHOUT THE EXPRESS WRITTEN CONSENT OF REEVE STORE EQUIPMENT CO. COPYRIGHT 2012, 2011, 2010, 2009, 2008, 2007, 2006, 2005, 2004, 2003, 2002. ALL RIGHTS RESERVED.

6 5 4 3 2 1

D

D

C

C

B

B

A

A

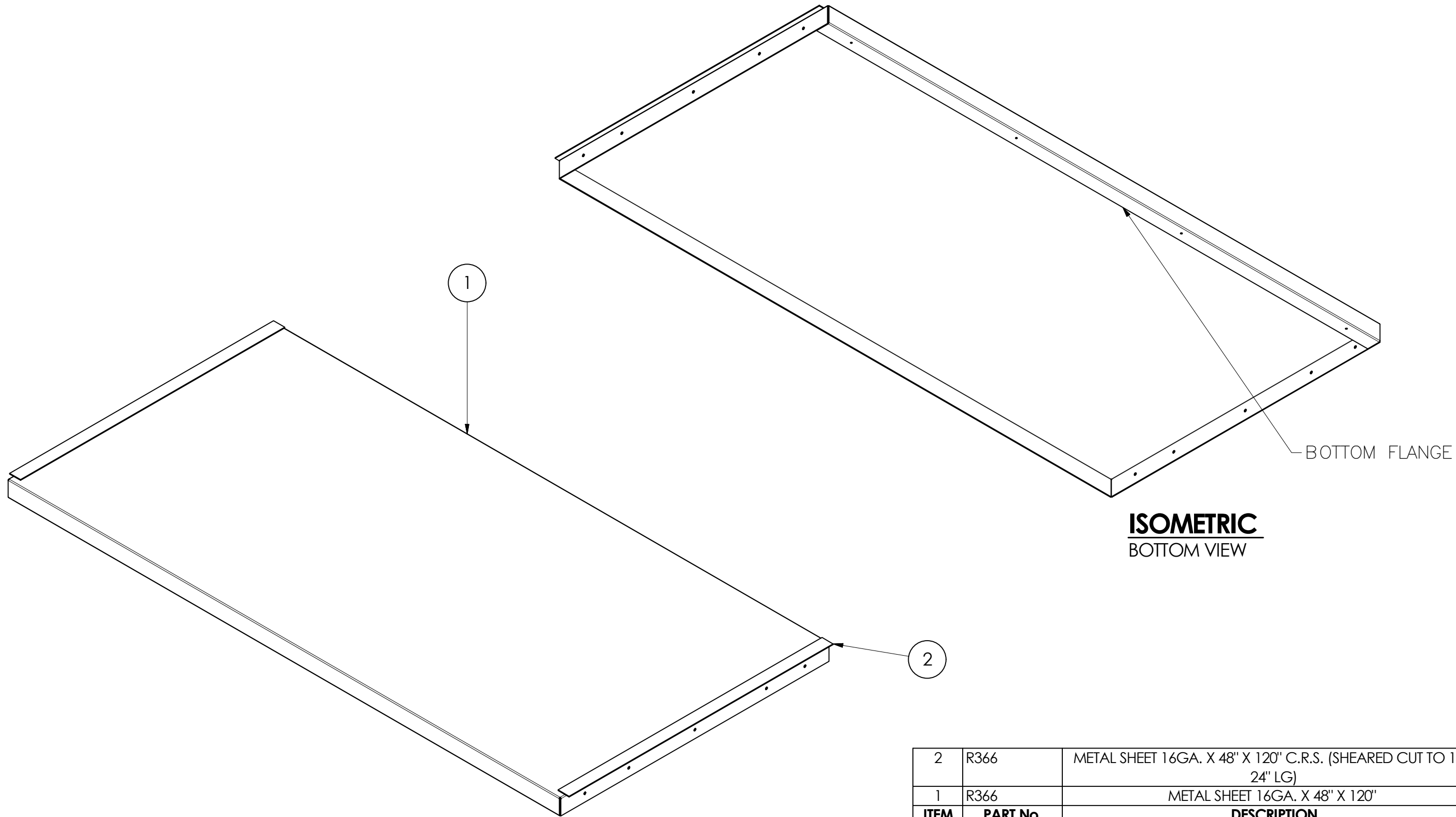

**ISOMETRIC**  
BOTTOM VIEW

| 2    | R366     | METAL SHEET 16GA. X 48" X 120" C.R.S. (SHEARED CUT TO 1" X 24" LG) | 2    |
|------|----------|--|------|
| 1    | R366     | METAL SHEET 16GA. X 48" X 120"                                     | 1    |
| ITEM | PART No. | DESCRIPTION  | QTY. |

BILL OF MATERIALS

UNLESS OTHERWISE SPECIFIED,  
DIMENSIONS ARE INCHES.  
TOLERANCES ARE:

|                        |   |                    |
|------------------------|---|--------------------|
| FRACTIONS:<br>+/- 1/32 | DECIMALS:<br>.xx +/- .01<br>.xxx +/- .005 | ANGLES:<br>+/- 1/2 |
| FINISH                 |   |                    |

|                               |          |
|-------------------------------|----------|
| CUSTOMER<br><b>FRED SEGAL</b> |          |
| APPROVALS                     | DATE     |
| DRAWN<br><b>JEL</b>           | 5/9/2014 |
| CHK'D.                        |          |
| APVD.                         |          |
| EQCB No.                      |          |

**REEVE**  
STORE EQUIPMENT CO.  
Pico Rivera, CA. (562) 949-2535

TITLE: **22E-02-CG MENS DISPLAY CASE METAL  
DRAWER BOTTOM PANEL**

|                  |                             |      |
|------------------|-----------------------------|------|
| SIZE<br><b>B</b> | DWG. No.<br><b>33001478</b> | REV. |
|------------------|-----------------------------|------|

THIS DRAWING IS THE EXCLUSIVE PROPERTY OF REEVE STORE EQUIPMENT CO. WHO HOLDS AND MAINTAINS FULL COPYRIGHT PROTECTION UNDER FEDERAL AND STATE LAW. THIS DRAWING CANNOT BE DUPLICATED, PHOTOCOPIED, DIGITALLY TRANSFERRED, OR REPRODUCED WITHOUT THE EXPRESS WRITTEN CONSENT OF REEVE STORE EQUIPMENT CO. COPYRIGHT 2012, 2011, 2010, 2009, 2008, 2007, 2006, 2005, 2004, 2003, 2002. ALL RIGHTS RESERVED.

DO NOT SCALE DRAWING

SCALE: N.T.S. SHEET: 1 OF 3

6 5 4 3 2 1

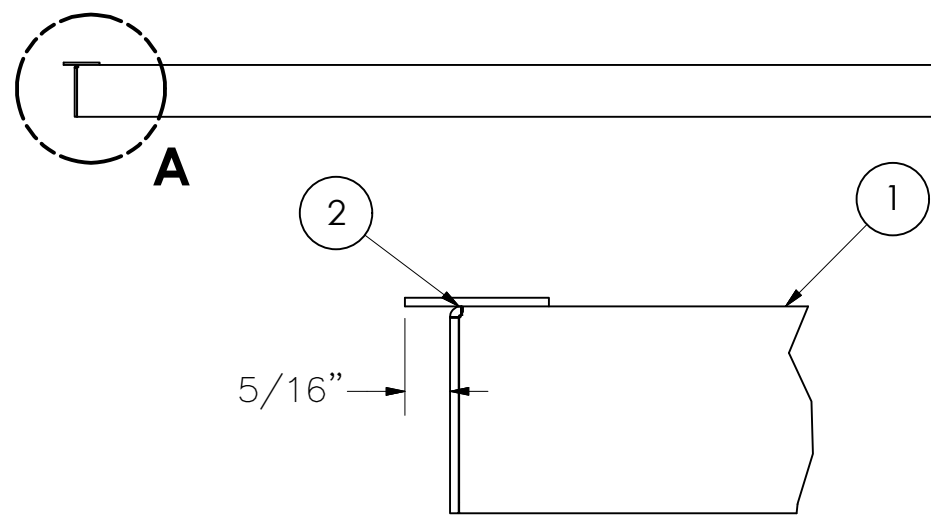
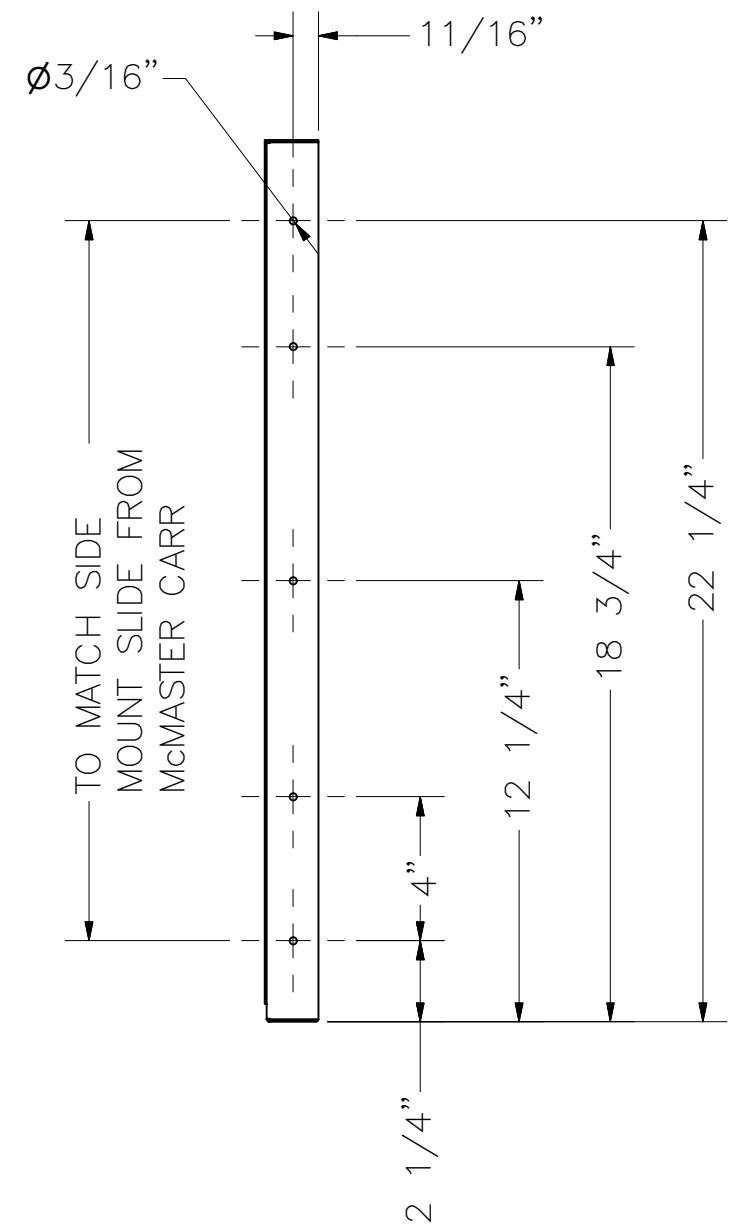
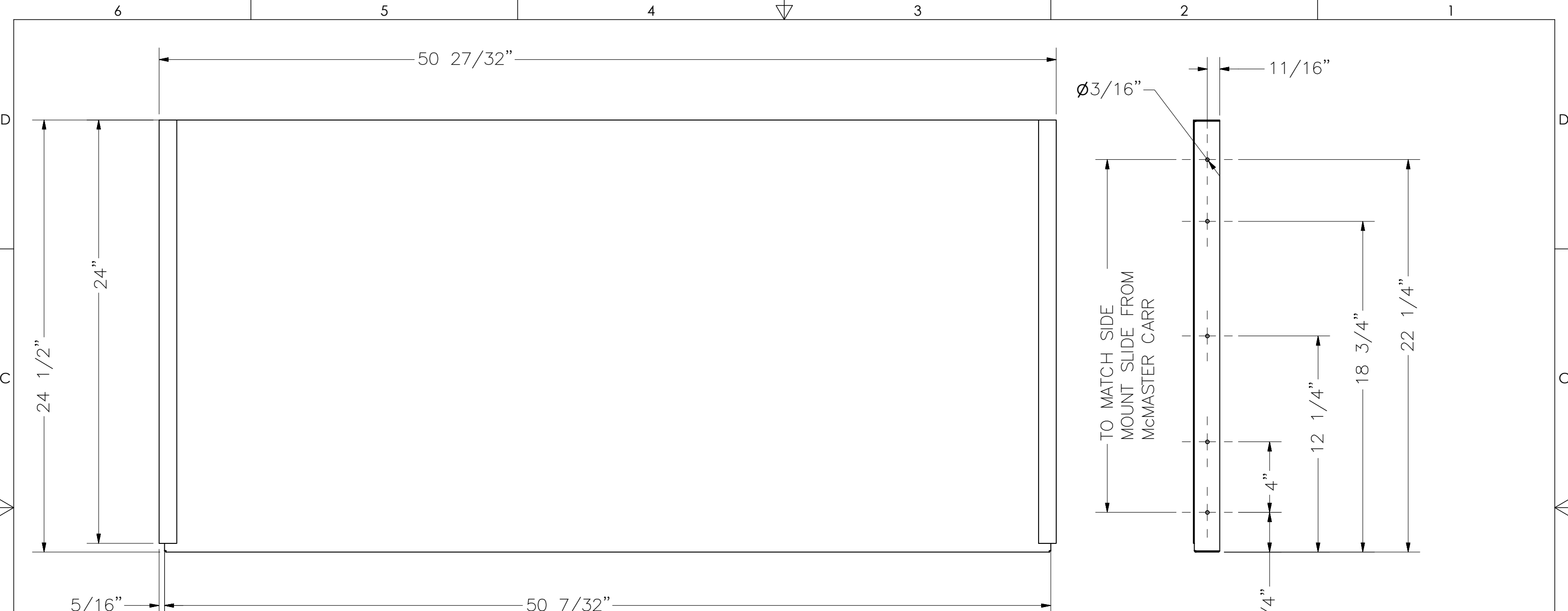

**DETAIL A**

|  |   |                    |                               |      |   |
|--|---|--------------------|-------------------------------|------|---|
| UNLESS OTHERWISE SPECIFIED, DIMENSIONS ARE INCHES. TOLERANCES ARE: |   |                    | CUSTOMER<br><b>FRED SEGAL</b> |      | <br>Pico Rivera, CA. (562) 949-2535                                   |
| FRACTIONS:<br>+/- 1/32   | DECIMALS:<br>.xx +/- .01<br>.xxx +/- .005 | ANGLES:<br>+/- 1/2 | APPROVALS                     | DATE |   |
| FINISH   |   |                    | CHK'D.                        |      |   |
| DO NOT SCALE DRAWING   |   |                    | APVD.                         |      |   |
|  |   |                    | EQCB No.                      |      | TITLE<br><b>22E-02-CG MENS DISPLAY CASE METAL DRAWER BOTTOM PANEL</b> |
|  |   |                    | DWG. No.<br><b>33001478</b>   |      | REV.  |
|  |   |                    | SCALE:<br>N.T.S.              |      | SHEET:<br>2 OF 3  |

THIS DRAWING IS THE EXCLUSIVE PROPERTY OF REEVE STORE EQUIPMENT CO. WHO HOLDS AND MAINTAINS FULL COPYRIGHT PROTECTION UNDER FEDERAL AND STATE LAW. THIS DRAWING CANNOT BE DUPLICATED, PHOTOCOPIED, DIGITALLY TRANSFERRED, OR REPRODUCED WITHOUT THE EXPRESS WRITTEN CONSENT OF REEVE STORE EQUIPMENT CO. COPYRIGHT 2012, 2011, 2010, 2009, 2008, 2007, 2006, 2005, 2004, 2003, 2002. ALL RIGHTS RESERVED.

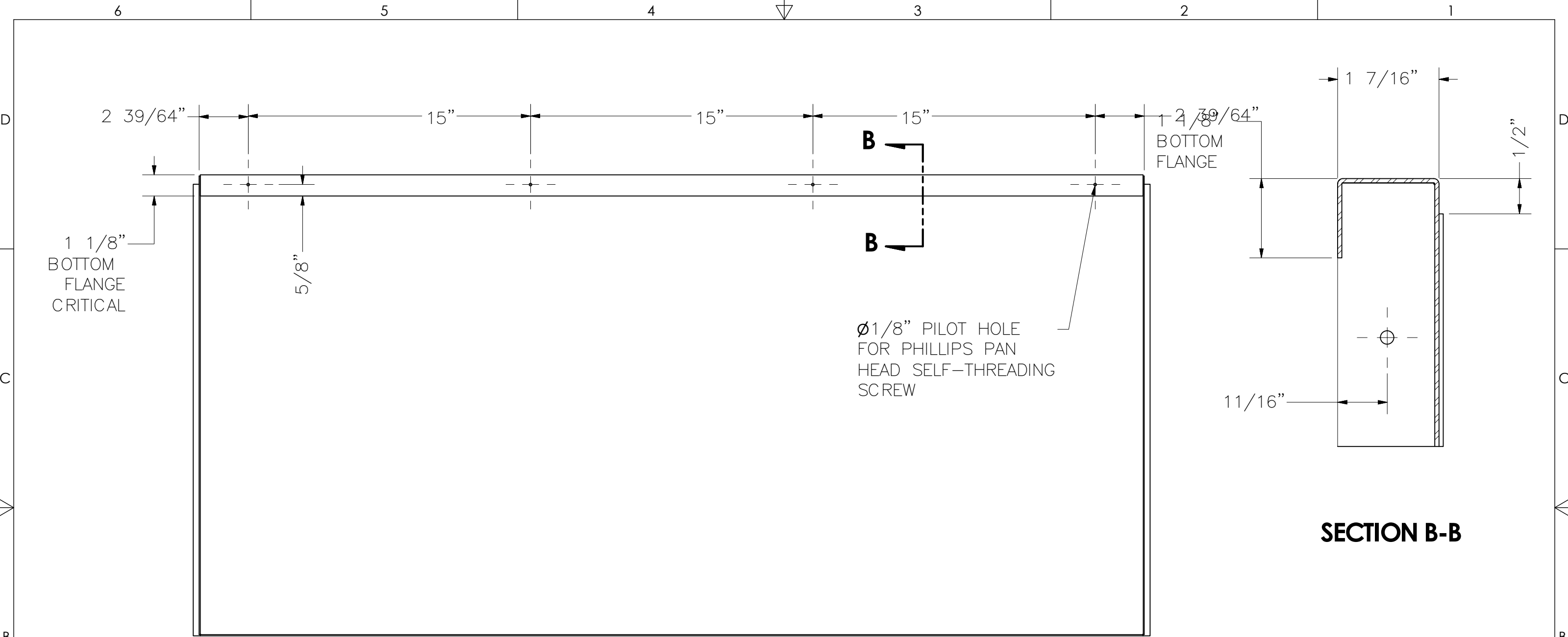

**BOTTOM VIEW**

**SECTION B-B**

|  |   |                    |                               |          |   |
|--|---|--------------------|-------------------------------|----------|---|
| UNLESS OTHERWISE SPECIFIED, DIMENSIONS ARE INCHES. TOLERANCES ARE: |   |                    | CUSTOMER<br><b>FRED SEGAL</b> |          | <br>STORE EQUIPMENT CO.<br>Pico Rivera, CA. (562) 949-2535            |
| FRACTIONS:<br>+/- 1/32   | DECIMALS:<br>.xx +/- .01<br>.xxx +/- .005 | ANGLES:<br>+/- 1/2 | APPROVALS                     | DATE     |   |
| FINISH   |   |                    | DRAWN<br><b>JEL</b>           | 5/9/2014 | TITLE<br><b>22E-02-CG MENS DISPLAY CASE METAL DRAWER BOTTOM PANEL</b> |
| DO NOT SCALE DRAWING   |   |                    | CHK'D.                        |          | SIZE<br><b>B</b>  |
|  |   |                    | APVD.                         |          | DWG. No.<br><b>33001478</b>   |
|  |   |                    | EQCB No.                      |          | REV.  |
|  |   |                    |                               |          | SCALE:<br><b>N.T.S.</b>   |
|  |   |                    |                               |          | SHEET:<br><b>3 OF 3</b>   |

THIS DRAWING IS THE EXCLUSIVE PROPERTY OF REEVE STORE EQUIPMENT CO. WHO HOLDS AND MAINTAINS FULL COPYRIGHT PROTECTION UNDER FEDERAL AND STATE LAW. THIS DRAWING CANNOT BE DUPLICATED, PHOTOCOPIED, DIGITALLY TRANSFERRED, OR REPRODUCED WITHOUT THE EXPRESS WRITTEN CONSENT OF REEVE STORE EQUIPMENT CO. COPYRIGHT 2012, 2011, 2010, 2009, 2008, 2007, 2006, 2005, 2004, 2003, 2002. ALL RIGHTS RESERVED.



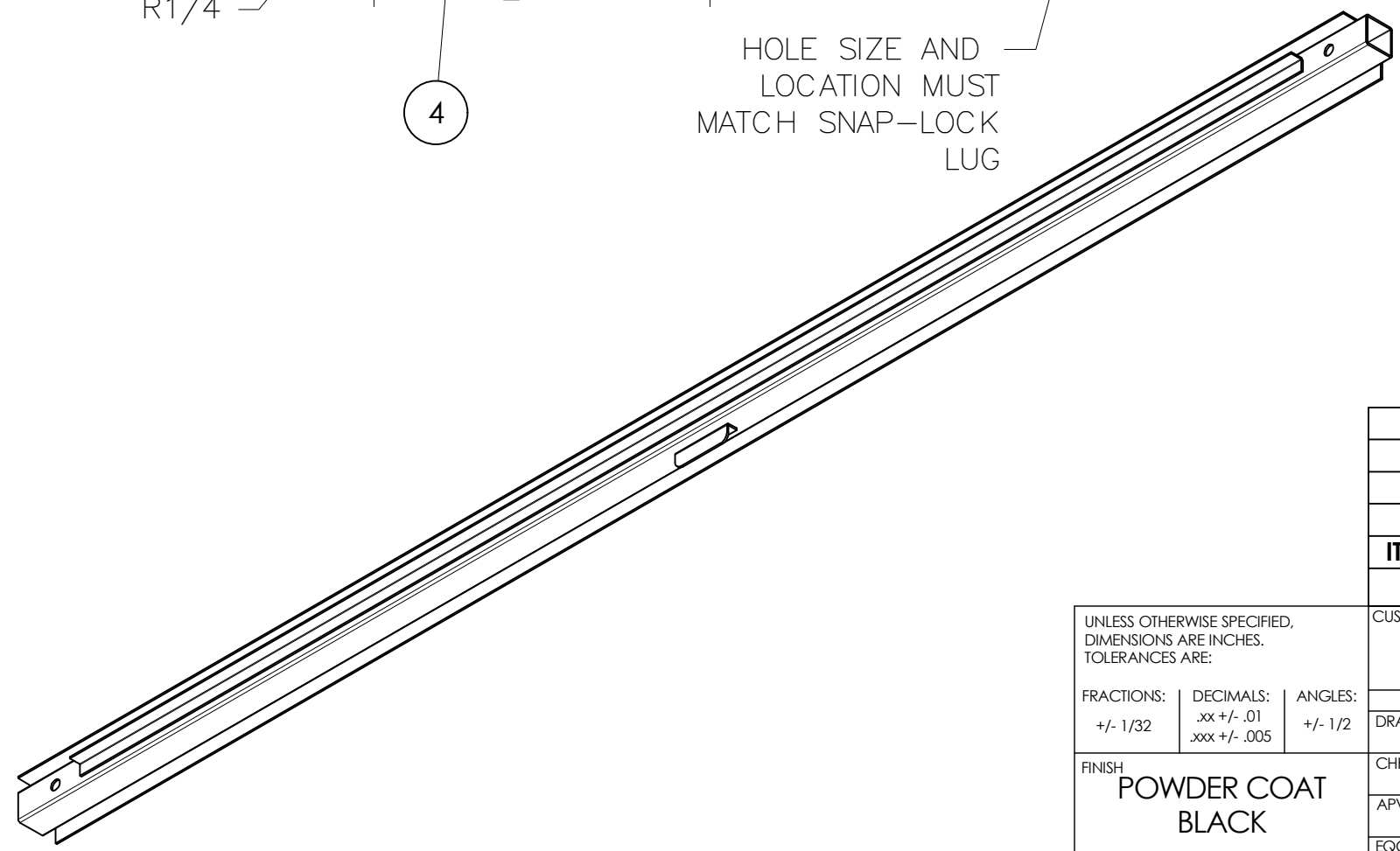
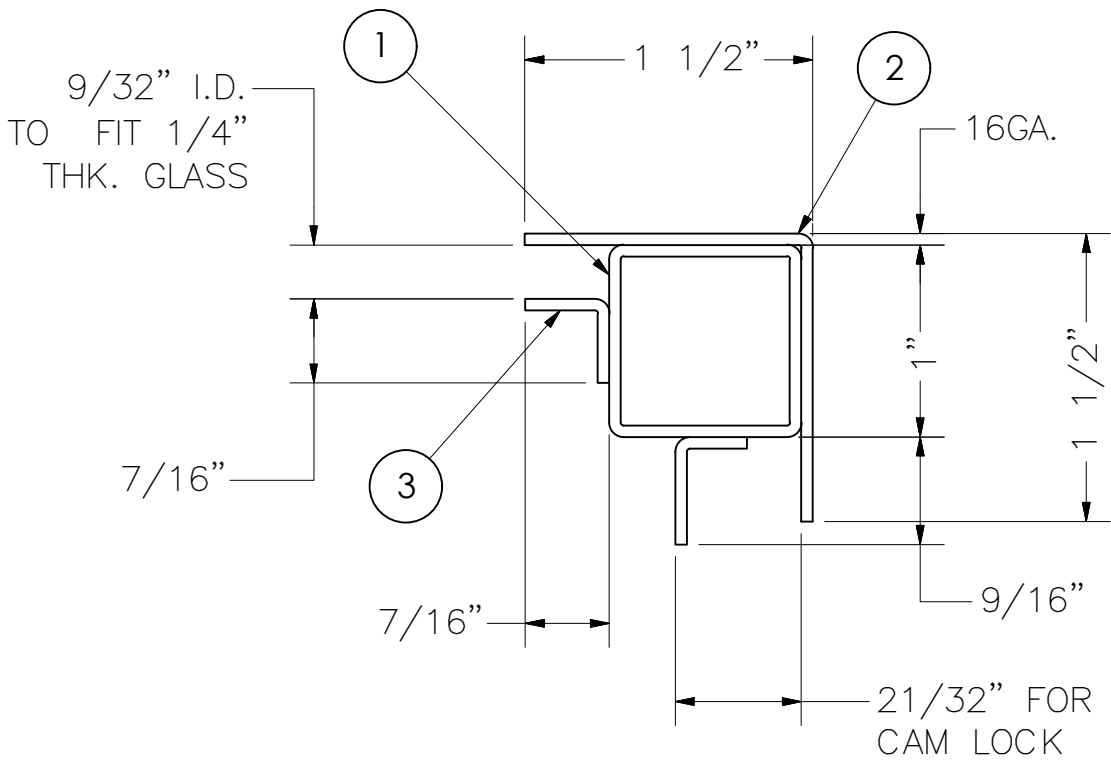
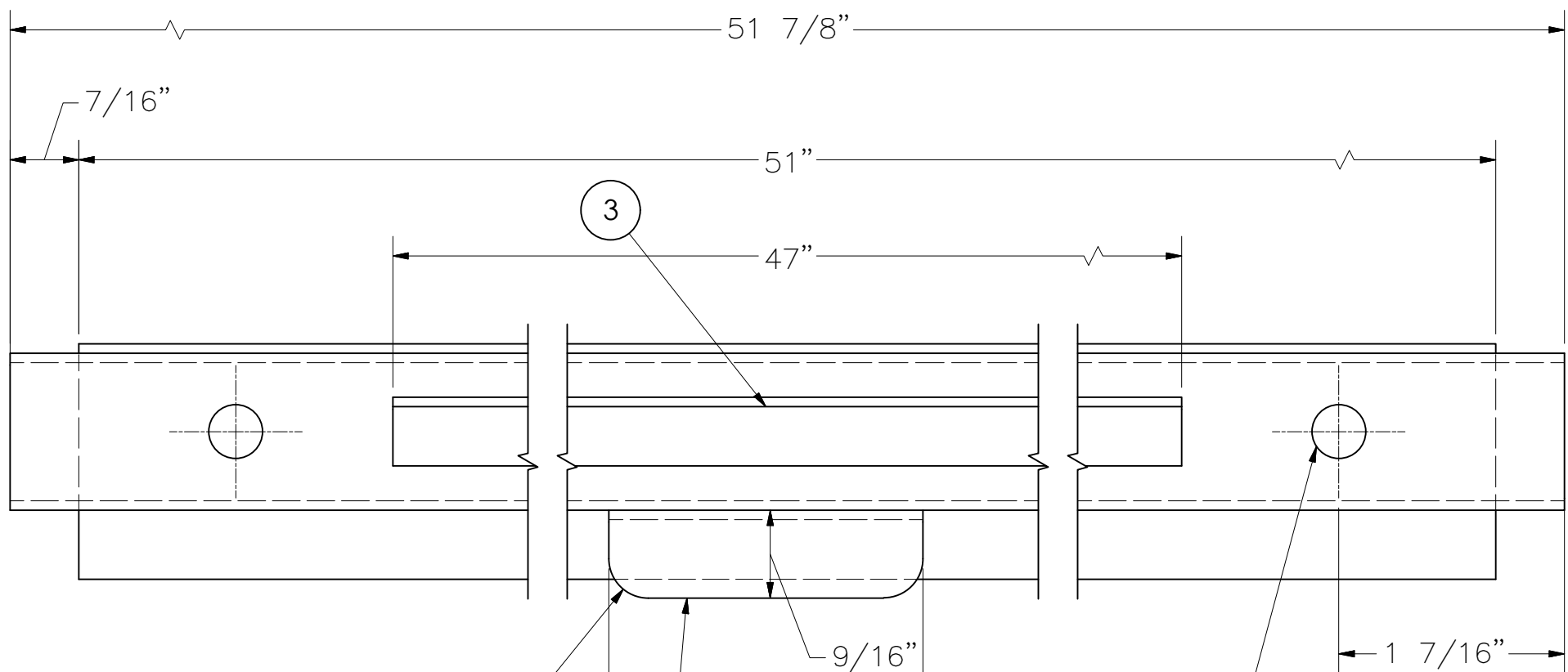

HOLE SIZE AND LOCATION MUST MATCH SNAP-LOCK LUG

| ITEM | PART No. | DESCRIPTION                           | QTY. |
|------|----------|---------------------------------------|------|
| 4    | R366     | METAL SHEET 16GA. X 48" X 120" C.R.S. | 1    |
| 3    | R366     | METAL SHEET 16GA. X 48" X 120" C.R.S. | 1    |
| 2    | R366     | METAL SHEET 16GA. X 48" X 120" C.R.S. | 1    |
| 1    | R70      | .060 x 1.00 SQ x 290 C.R. TUBE (85)   | 1    |

BILL OF MATERIALS

|  |  |            |              |
|--|--|------------|--------------|
| UNLESS OTHERWISE SPECIFIED, DIMENSIONS ARE INCHES. TOLERANCES ARE: |  | CUSTOMER   |              |
| FRACTIONS: +/- 1/32  | DECIMALS: .xx +/- .01<br>.xxx +/- .005 | FRED SEGAL |              |
| ANGLES: +/- 1/2  |  | APPROVALS  | DATE         |
| FINISH   |  | DRAWN      | JEL 5/9/2014 |
| POWDER COAT BLACK  |  | CHK'D.     |              |
| DO NOT SCALE DRAWING   |  | APVD.      |              |
|  |  | EQCB No.   |              |

**REEVE**  
STORE EQUIPMENT CO.  
Pico Rivera, CA. (562) 949-2535

TITLE: 22E-02-CG MENS DISPLAY CASE METAL TOP STRETCHER - KEY SLOT

SIZE B DWG. No. 33001479 REV.

SCALE: N.T.S. SHEET: 1 OF 1

THIS DRAWING IS THE EXCLUSIVE PROPERTY OF REEVE STORE EQUIPMENT CO. WHO HOLDS AND MAINTAINS FULL COPYRIGHT PROTECTION UNDER FEDERAL AND STATE LAW. THIS DRAWING CANNOT BE DUPLICATED, PHOTOCOPIED, DIGITALLY TRANSFERRED, OR REPRODUCED WITHOUT THE EXPRESS WRITTEN CONSENT OF REEVE STORE EQUIPMENT CO. COPYRIGHT 2012, 2011, 2010, 2009, 2008, 2007, 2006, 2005, 2004, 2003, 2002. ALL RIGHTS RESERVED.

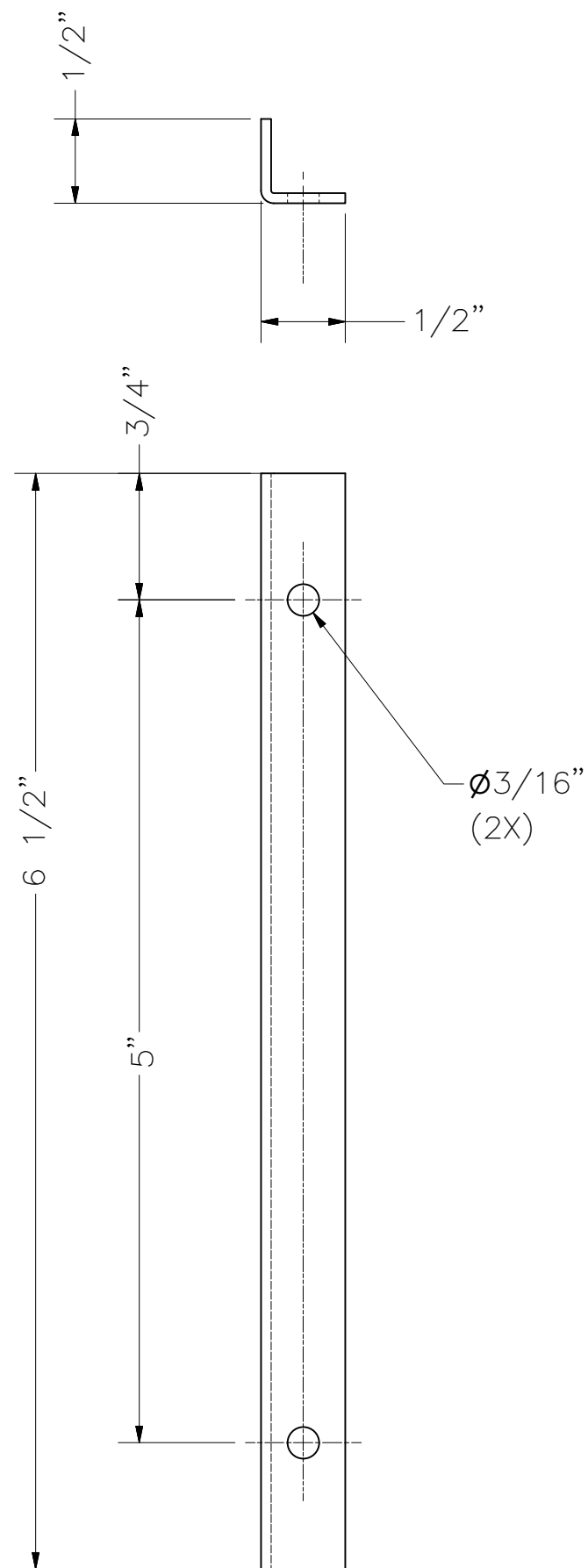

UNLESS OTHERWISE SPECIFIED,  
DIMENSIONS ARE INCHES.  
TOLERANCES ARE:

|                        |   |                    |
|------------------------|---|--------------------|
| FRACTIONS:<br>+/- 1/32 | DECIMALS:<br>.xx +/- .01<br>.xxx +/- .005 | ANGLES:<br>+/- 1/2 |
|------------------------|---|--------------------|

FINISH  
**POWDER COAT  
BLACK**

**DO NOT SCALE DRAWING**

| 1                             | R366      | METAL SHEET 16GA. X 48" X 120" C.R.S.                                    | 1                |
|-------------------------------|-----------|--|------------------|
| ITEM                          | PART No.  | DESCRIPTION  | QTY.             |
| BILL OF MATERIALS             |           |  |                  |
| CUSTOMER<br><b>FRED SEGAL</b> |           | <br>Pico Rivera, CA. (562) 949-2535                                      |                  |
| APPROVALS                     | DATE      |  |                  |
| DRAWN<br>JEL                  | 5/12/2014 | TITLE<br><b>22E-02-CG MENS DISPLAY CASE SIDE GLASS<br/>PANEL STOPPER</b> |                  |
| CHK'D.                        |           | SIZE<br>B  | REV.             |
| APVD.                         |           | DWG. No.<br><b>33001480</b>  |                  |
| EQCB No.                      |           | SCALE:<br>N.T.S.   | SHEET:<br>1 OF 1 |

6 5 4 3 2 1

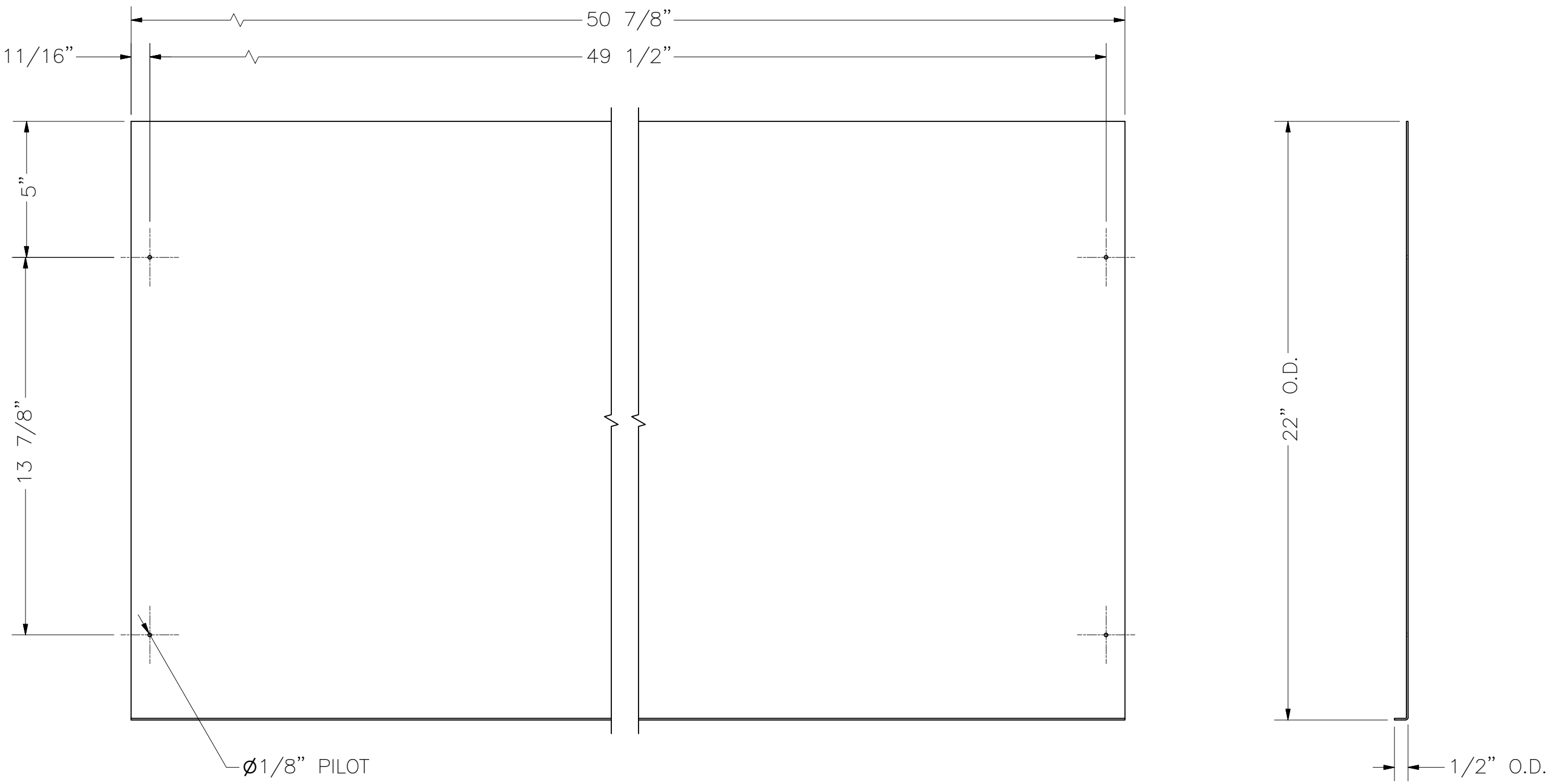

∅1/8" PILOT HOLE FOR 8-18 SELF-THREADING SCREW (4X)

UNLESS OTHERWISE SPECIFIED, DIMENSIONS ARE INCHES. TOLERANCES ARE:

|                        |   |                    |
|------------------------|---|--------------------|
| FRACTIONS:<br>+/- 1/32 | DECIMALS:<br>.xx +/- .01<br>.xxx +/- .005 | ANGLES:<br>+/- 1/2 |
|------------------------|---|--------------------|

FINISH  
**POWDER COAT  
BLACK**

*DO NOT SCALE DRAWING*

| 1                                  | R366      | METAL SHEET 16GA. X 48" X 120" C.R.S.                          | 1                           |
|------------------------------------|-----------|--|-----------------------------|
| ITEM                               | PART No.  | DESCRIPTION  | QTY.                        |
| BILL OF MATERIALS                  |           |  |                             |
| CUSTOMER<br><b>FRED SEGAL</b>      |           | <br>Pico Rivera, CA. (562) 949-2535                            |                             |
| APPROVALS                          | DATE      |  |                             |
| DRAWN<br><b>JEL</b>                | 5/12/2014 |  |                             |
| CHK'D.                             |           |  |                             |
| FINISH<br><b>POWDER COAT BLACK</b> |           | TITLE<br><b>22E-02-CG MENS DISPLAY CASE BOTTOM FRAME PANEL</b> |                             |
| APVD.                              |           | SIZE<br><b>B</b>   | DWG. No.<br><b>33001481</b> |
| EQCB No.                           |           | SCALE:<br><b>N.T.S.</b>  | REV.                        |
|                                    |           |  | SHEET:<br><b>1 OF 1</b>     |

THIS DRAWING IS THE EXCLUSIVE PROPERTY OF REEVE STORE EQUIPMENT CO. WHO HOLDS AND MAINTAINS FULL COPYRIGHT PROTECTION UNDER FEDERAL AND STATE LAW. THIS DRAWING CANNOT BE DUPLICATED, PHOTOCOPIED, DIGITALLY TRANSFERRED, OR REPRODUCED WITHOUT THE EXPRESS WRITTEN CONSENT OF REEVE STORE EQUIPMENT CO. COPYRIGHT 2012, 2011, 2010, 2009, 2008, 2007, 2006, 2005, 2004, 2003, 2002. ALL RIGHTS RESERVED.

6 5 4 3 2 1

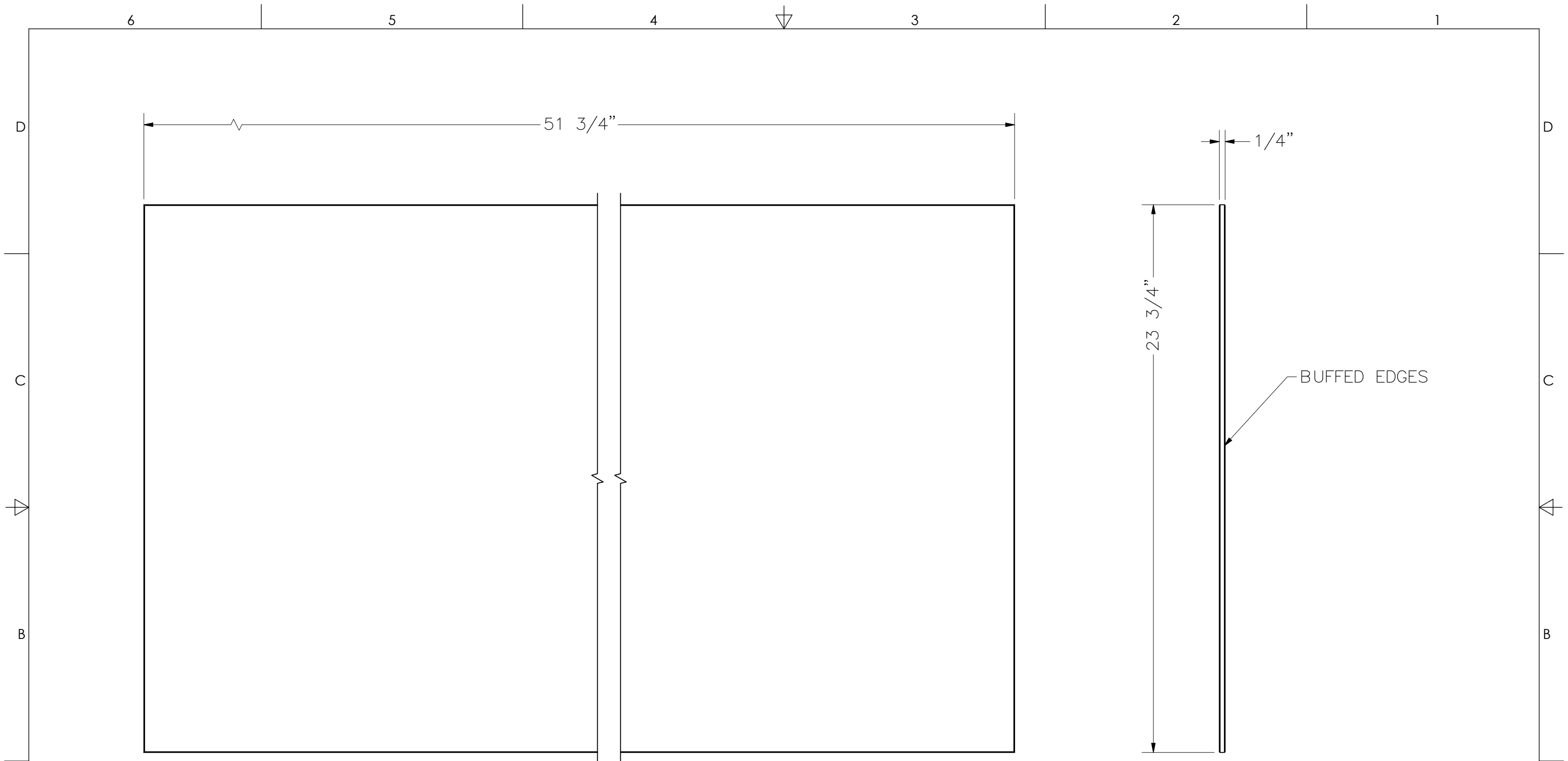

UNLESS OTHERWISE SPECIFIED,  
DIMENSIONS ARE INCHES.  
TOLERANCES ARE:

| FRACTIONS: | DECIMALS:                    | ANGLES: |
|------------|------------------------------|---------|
| +/- 1/32   | .xx +/- .01<br>.xxx +/- .005 | +/- 1/2 |

FINISH  
**CLEAR TEMPERED**

*DO NOT SCALE DRAWING*

CUSTOMER  
**FRED SEGAL**

| APPROVALS        | DATE     |
|------------------|----------|
| DRAWN <b>JEL</b> | 5/6/2014 |

CHK'D.

APVD.

EQCB No.

**REEVE**  
STORE EQUIPMENT CO.  
Pico Rivera, CA. (562) 949-2535

TITLE  
**22E-02-CG MENS DISPLAY CASE GLASS TOP**

|                  |                             |      |
|------------------|-----------------------------|------|
| SIZE<br><b>B</b> | DWG. No.<br><b>62000964</b> | REV. |
|------------------|-----------------------------|------|

|                         |                         |
|-------------------------|-------------------------|
| SCALE:<br><b>N.T.S.</b> | SHEET:<br><b>1 OF 1</b> |
|-------------------------|-------------------------|

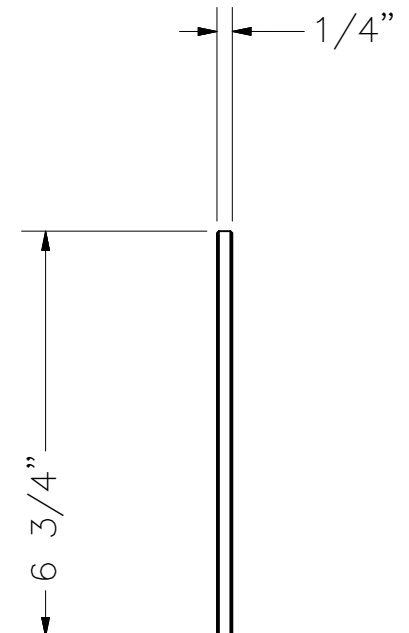
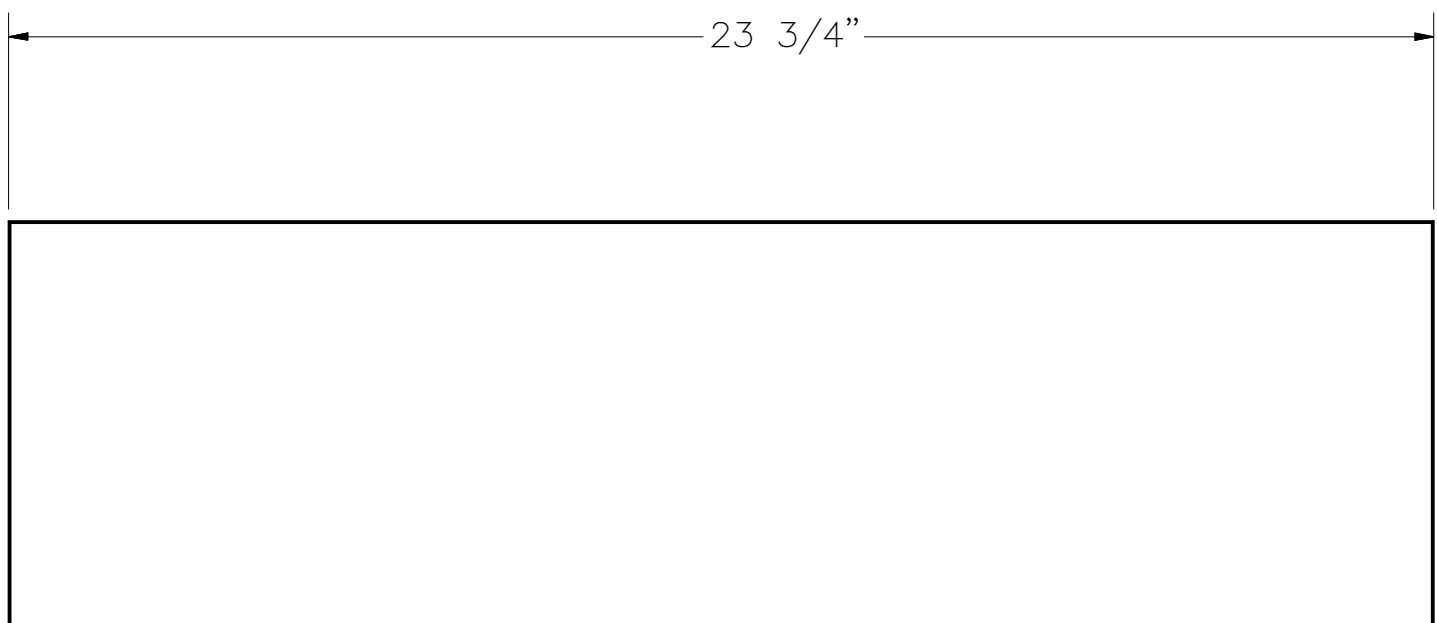

UNLESS OTHERWISE SPECIFIED,  
DIMENSIONS ARE INCHES.  
TOLERANCES ARE:

| FRACTIONS: | DECIMALS:                    | ANGLES: |
|------------|------------------------------|---------|
| +/- 1/32   | .xx +/- .01<br>.xxx +/- .005 | +/- 1/2 |

FINISH  
**CLEAR TEMPERED**

*DO NOT SCALE DRAWING*

|                               |          |
|-------------------------------|----------|
| CUSTOMER<br><b>FRED SEGAL</b> |          |
| APPROVALS                     | DATE     |
| DRAWN <b>JEL</b>              | 5/6/2014 |
| CHK'D.                        |          |
| APVD.                         |          |
| EQCB No.                      |          |

|  |                          |      |
|--|--------------------------|------|
| <br>STORE EQUIPMENT CO.<br>Pico Rivera, CA. (562) 949-2535 |                          |      |
| TITLE <b>22E-02-CG MENS DISPLAY CASE GLASS SIDE PANEL</b>  |                          |      |
| SIZE <b>B</b>  | DWG. No. <b>62000965</b> | REV. |
| SCALE: <b>N.T.S.</b>                                       | SHEET: <b>1 OF 1</b>     |      |

THIS DRAWING IS THE EXCLUSIVE PROPERTY OF REEVE STORE EQUIPMENT CO. WHO HOLDS AND MAINTAINS FULL COPYRIGHT PROTECTION UNDER FEDERAL AND STATE LAW. THIS DRAWING CANNOT BE DUPLICATED, PHOTOCOPIED, DIGITALLY TRANSFERRED, OR REPRODUCED WITHOUT THE EXPRESS WRITTEN CONSENT OF REEVE STORE EQUIPMENT CO. COPYRIGHT 2012, 2011, 2010, 2009, 2008, 2007, 2006, 2005, 2004, 2003, 2002. ALL RIGHTS RESERVED.

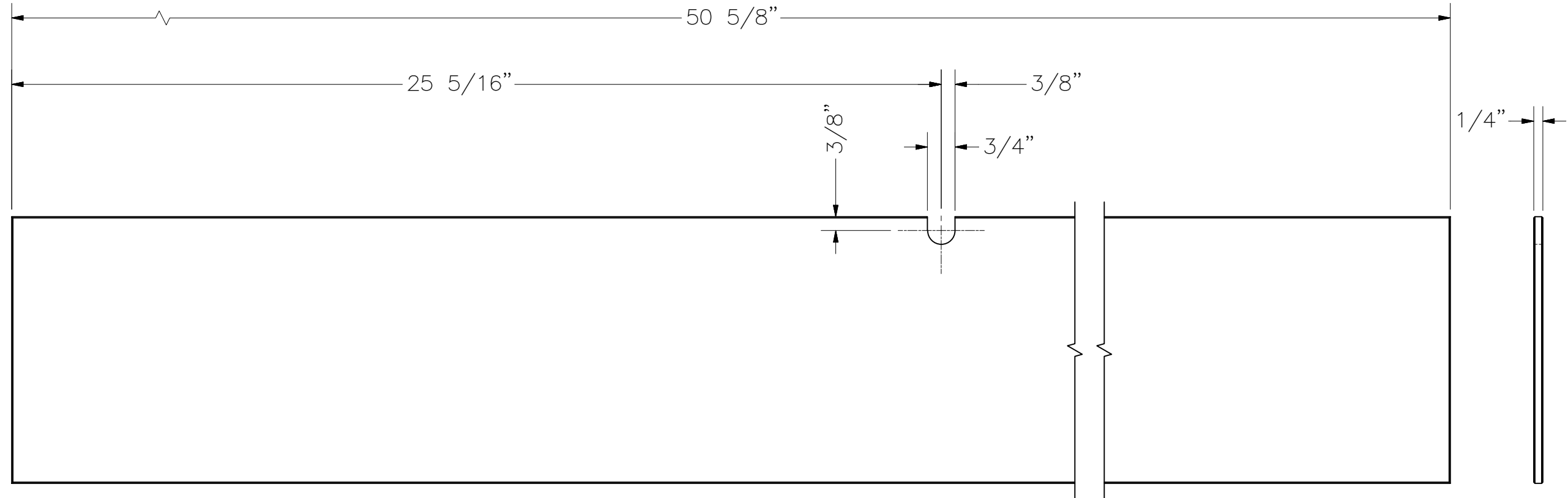

UNLESS OTHERWISE SPECIFIED,  
DIMENSIONS ARE INCHES.  
TOLERANCES ARE:

|                        |   |                    |
|------------------------|---|--------------------|
| FRACTIONS:<br>+/- 1/32 | DECIMALS:<br>.xx +/- .01<br>.xxx +/- .005 | ANGLES:<br>+/- 1/2 |
|------------------------|---|--------------------|

FINISH  
**CLEAR TEMPERED**

**DO NOT SCALE DRAWING**

CUSTOMER  
**FRED SEGAL**

|                  |          |
|------------------|----------|
| APPROVALS        | DATE     |
| DRAWN <b>JEL</b> | 5/9/2014 |

CHK'D.

APVD.

EQCB No.

**REEVE**

STORE EQUIPMENT CO.  
Pico Rivera, CA. (562) 949-2535

TITLE **22E-02-CG MENS DISPLAY CASE GLASS  
DOOR PANEL**

SIZE **B** DWG. No. **62000966** REV.

SCALE: **N.T.S.** SHEET: **1 OF 1**

6 5 4 3 2 1

D

D

C

C

B

B

A

A

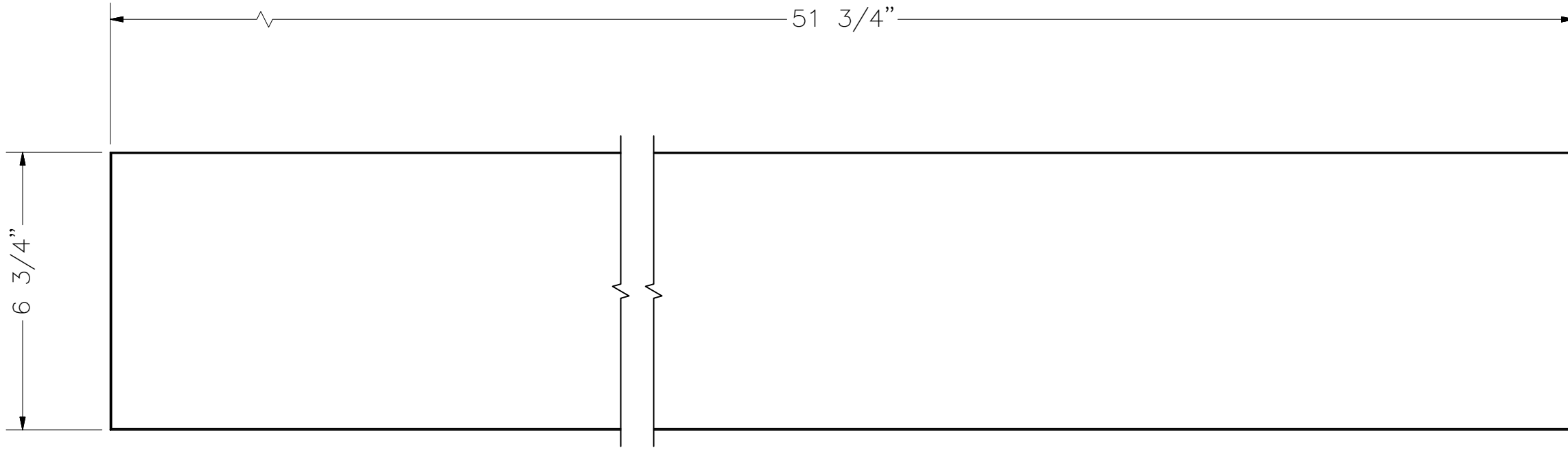

1/4"

|  |   |                    |                               |          |  |                         |
|--|---|--------------------|-------------------------------|----------|--|-------------------------|
| UNLESS OTHERWISE SPECIFIED,<br>DIMENSIONS ARE INCHES.<br>TOLERANCES ARE: |   |                    | CUSTOMER<br><b>FRED SEGAL</b> |          | <br>STORE EQUIPMENT CO.<br>Pico Rivera, CA. (562) 949-2535 |                         |
| FRACTIONS:<br>+/- 1/32   | DECIMALS:<br>.xx +/- .01<br>.xxx +/- .005 | ANGLES:<br>+/- 1/2 | APPROVALS                     | DATE     |  |                         |
| FINISH<br><b>CLEAR TEMPERED</b>  |   |                    | DRAWN<br><b>JEL</b>           | 5/9/2014 | <b>22E-02-CG DISPLAY CASE GLASS FRONT<br/>PANEL</b>        |                         |
| <b>DO NOT SCALE DRAWING</b>  |   |                    | CHK'D.                        |          |  | SIZE<br><b>B</b>        |
|  |   |                    | APVD.                         |          | DWG. No.<br><b>62000967</b>                                | REV.                    |
|  |   |                    | EQCB No.                      |          | SCALE:<br><b>N.T.S.</b>                                    | SHEET:<br><b>1 OF 1</b> |

THIS DRAWING IS THE EXCLUSIVE PROPERTY OF REEVE STORE EQUIPMENT CO. WHO HOLDS AND MAINTAINS FULL COPYRIGHT PROTECTION UNDER FEDERAL AND STATE LAW. THIS DRAWING CANNOT BE DUPLICATED, PHOTOCOPIED, DIGITALLY TRANSFERRED, OR REPRODUCED WITHOUT THE EXPRESS WRITTEN CONSENT OF REEVE STORE EQUIPMENT CO. COPYRIGHT 2012, 2011, 2010, 2009, 2008, 2007, 2006, 2005, 2004, 2003, 2002. ALL RIGHTS RESERVED.

6 5 4 3 2 1