

BILL OF MATERIALS / POKEPOP / GROUP 4

ITEM NO.	PART NAME	DESCRIPTION / MATERIAL	QTY.
1	METAL PIN	Stainless steel	3
2	MAIN COVER	transparant polypropylene	1
3	FLAP	transparant polypropylene	3
4	HEAT PLATE	Stainless steel - teflon coated	1
5	SYLYCONE MOUNT	silicone rubber	1
6	HANGER R	colored polypropylene	3
7	HANGER L	colored polypropylene	3
8	HEAT TRANSFORMATOR	heat wire transformer	1
9	HEAT COIL	nicron wire incapsulated	1
10	ISOLATION I	melamine isolation foam	1
11	ISOLATION H	melamine isolation foam	1
12	BUTTOM SHELL	colored polypropylene	1
13	SKREW 1	M1.6 flathead skrew	4
14	VIBRATION ENGINE	12v dc dual / vibration motor	1
15	BUTTOM CAP	colored polypropylene	1
16	SKREW 1	M1.6 eye head skrew	4
17	ELECTRIC CABLE	standard 4 mm cord	1
18	BAND	silicone rubber	1
19	SWITCH	push ON/OFF Switch	1

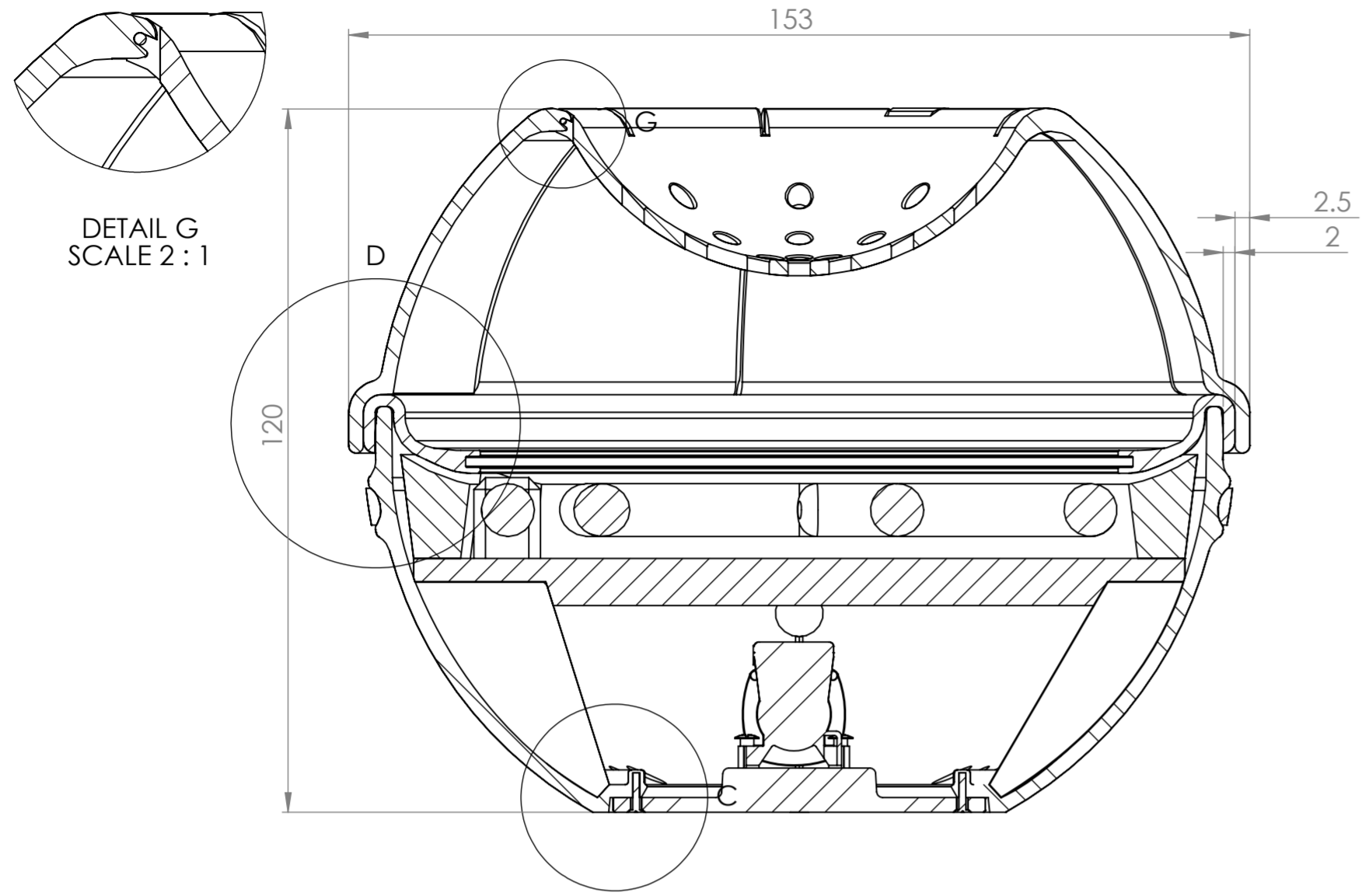

DETAIL G
SCALE 2:1

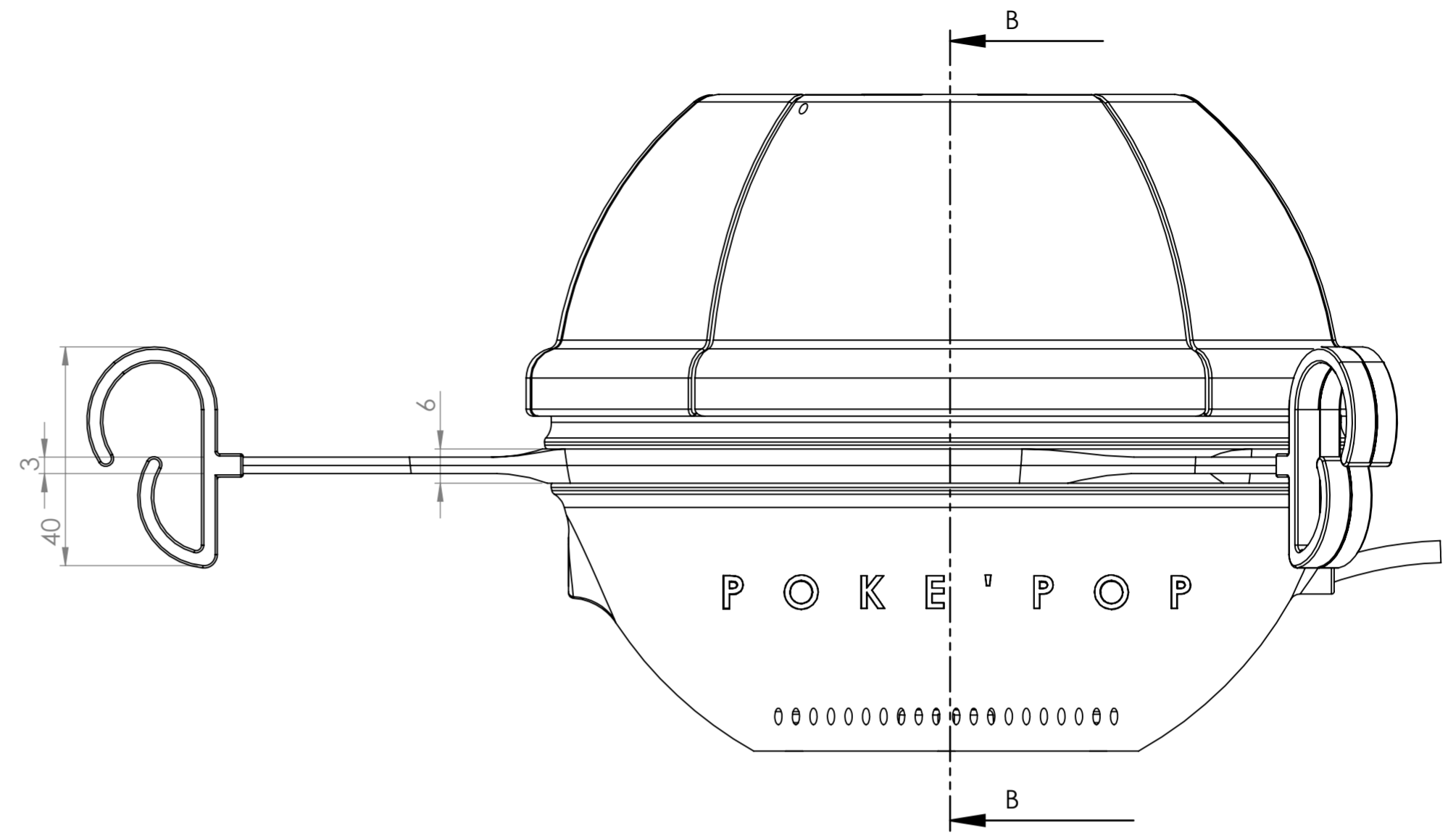

SECTION B-B
SCALE 1:1

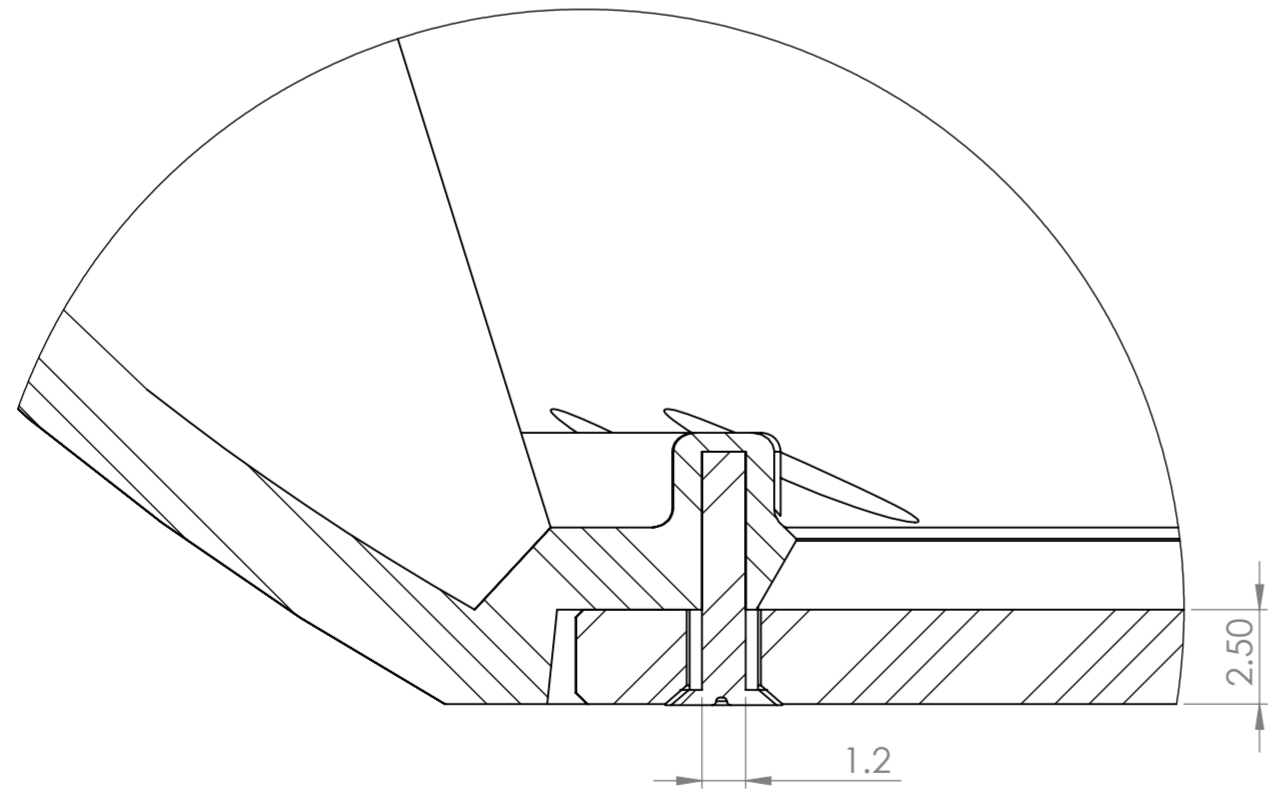

DETAIL C
SCALE 5:1

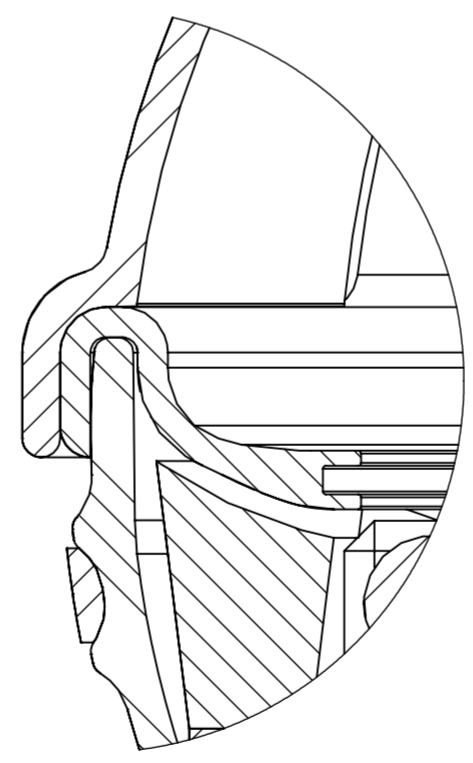

DETAIL D
SCALE 2:1

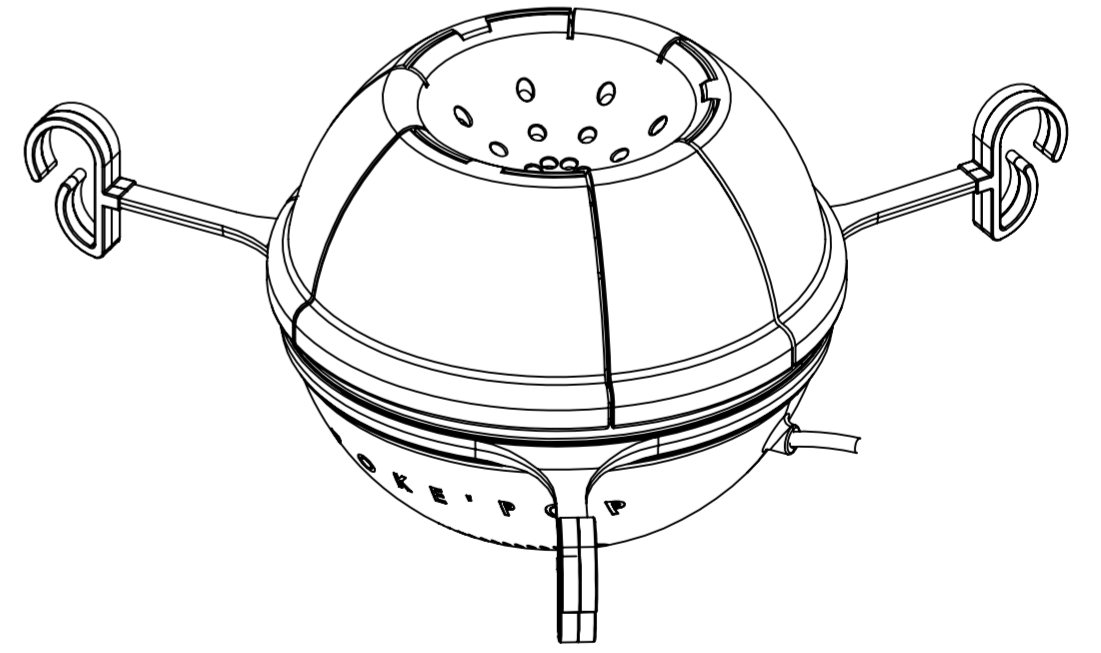

DO NOT SCALE DRAWING	REVISION
GROUP 4	
TITLE: OVERVIEW	
DWG NO. POKEPOP ASSEMBLY	A2
SCALE:1:1	

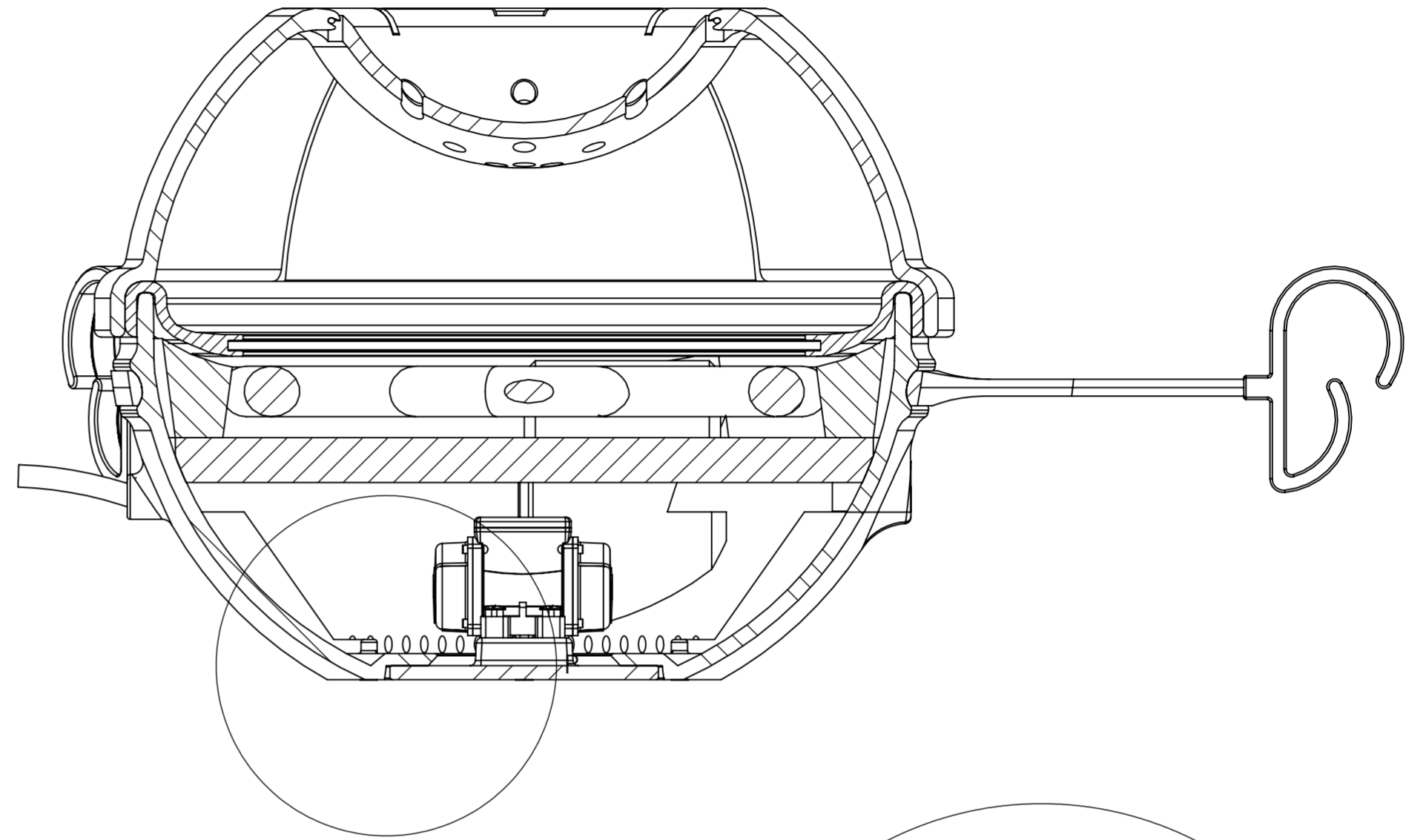
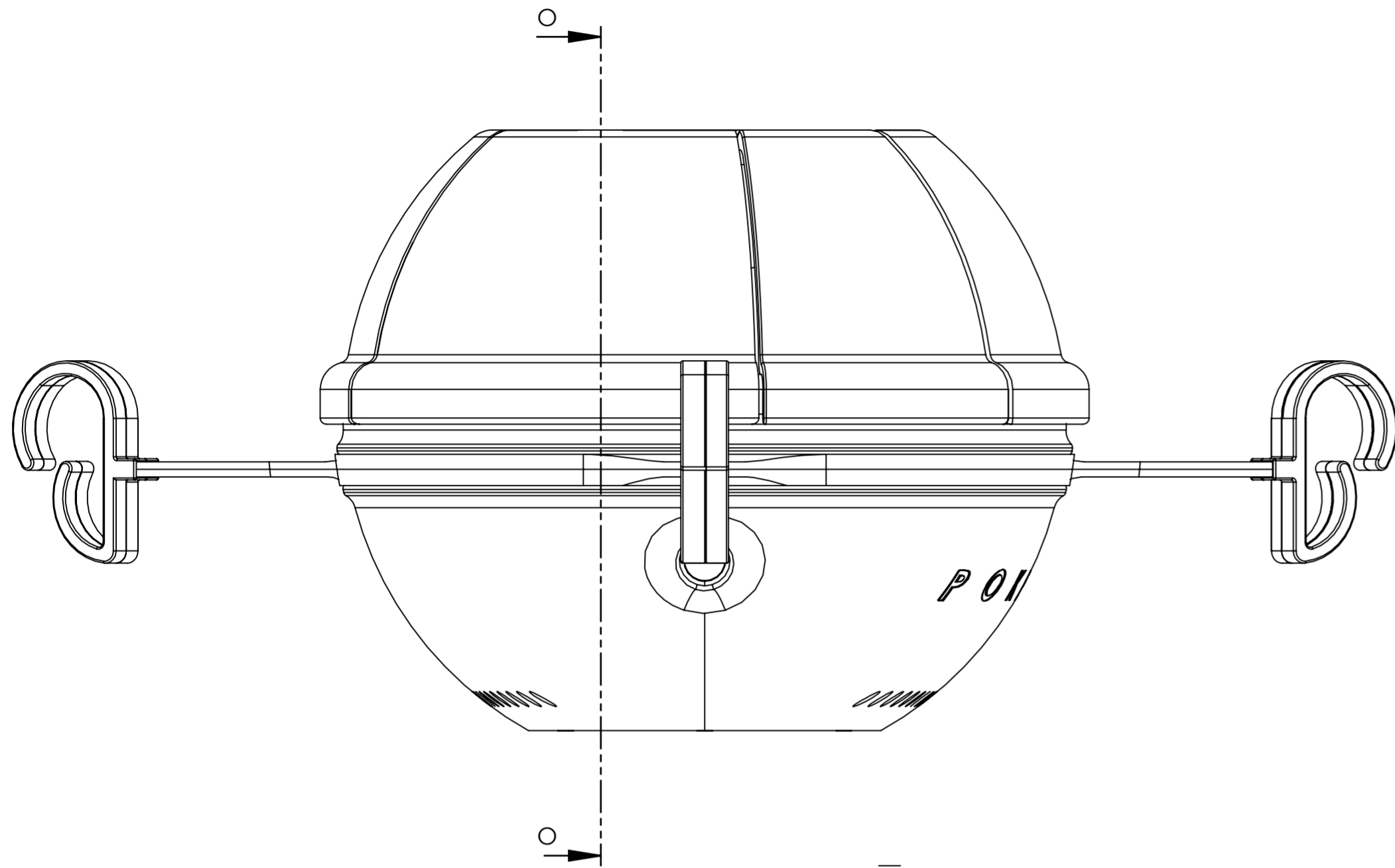

SECTION O-O
SCALE 1 : 1

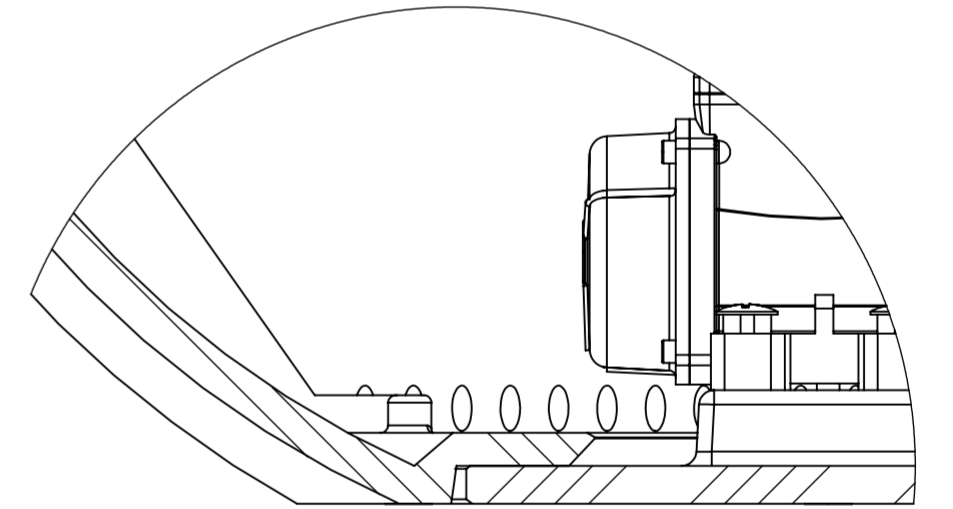

DETAIL P
SCALE 2 : 1

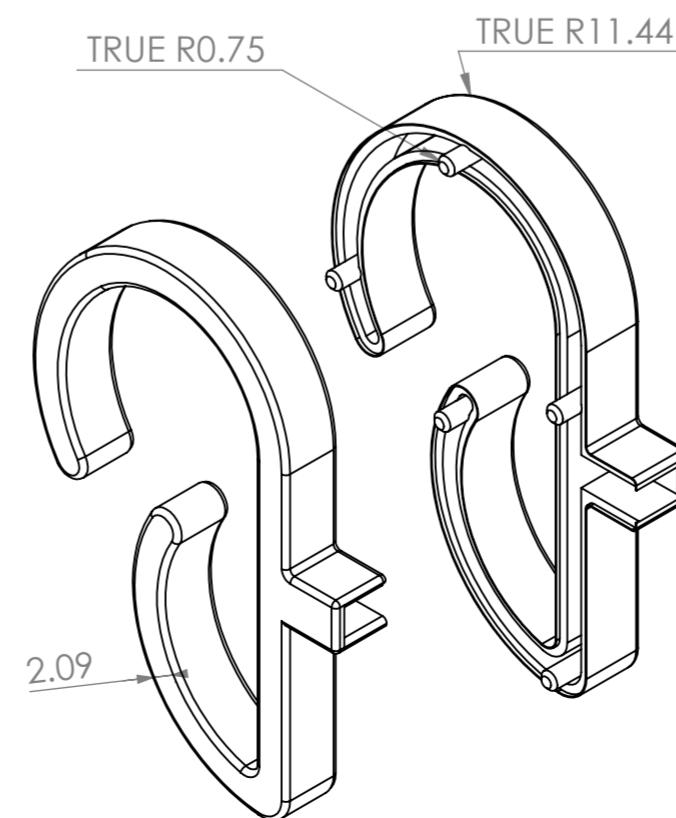
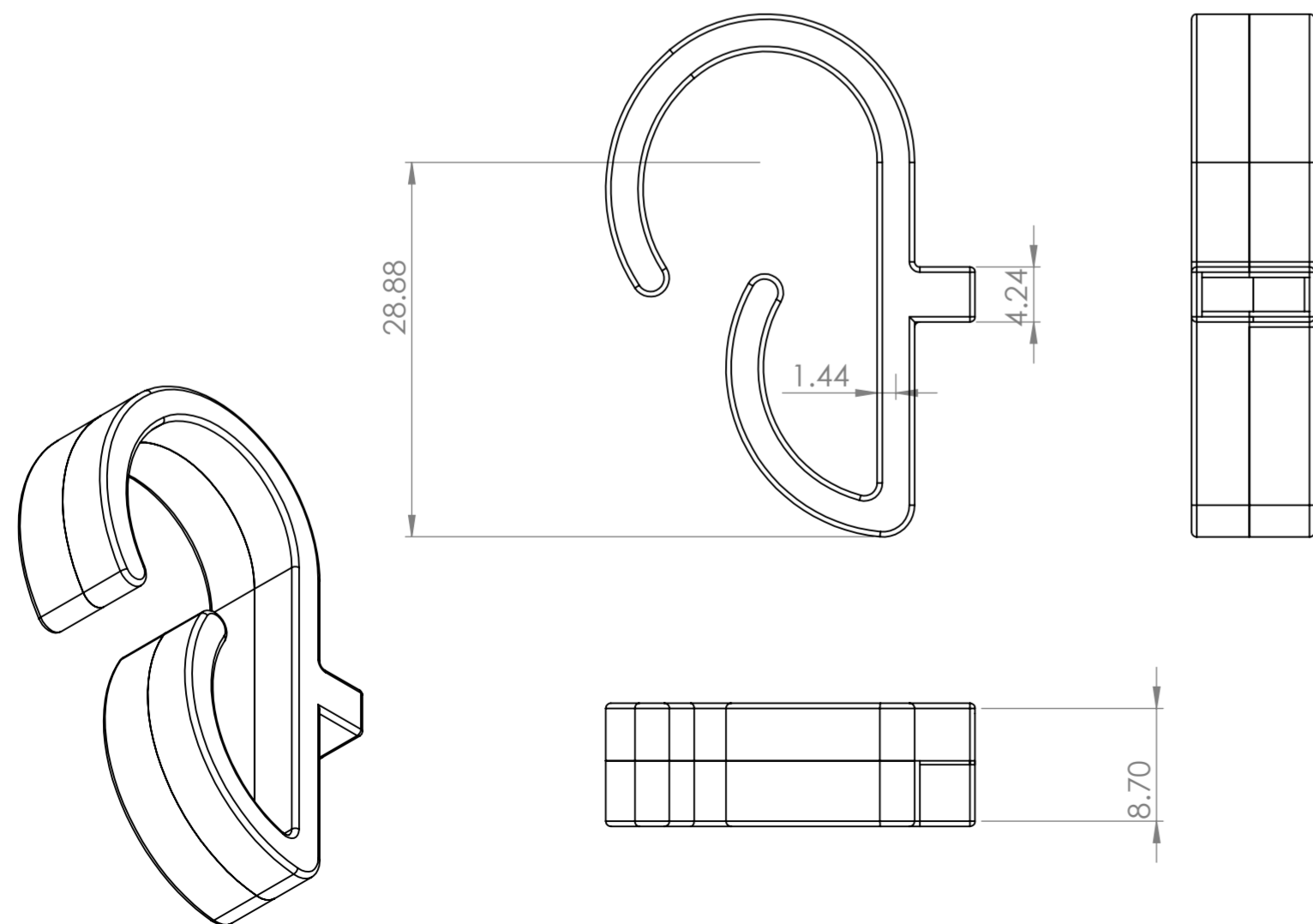

DO NOT SCALE DRAWING	REVISION
GROUP 4	
TITLE: OVERVIEW + CLAW	
DWG NO. POKEPOP ASSEMBLY	A2
SCALE:1:1	

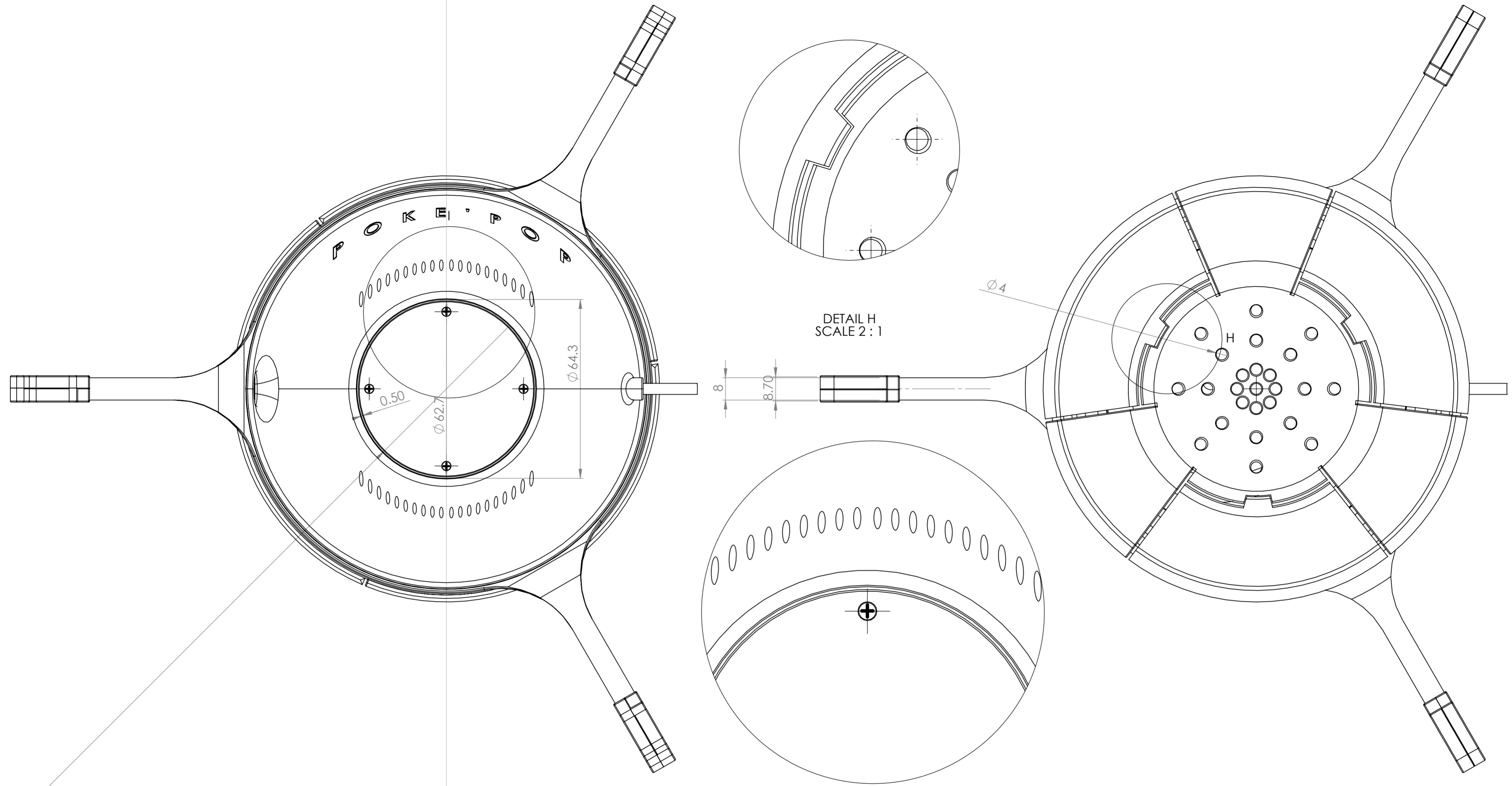

DETAIL H
SCALE 2 : 1

DETAIL I
SCALE 2 : 1

DO NOT SCALE DRAWING	REVISION
GROUP 4	
TITLE: OVERVIEW	
DWG NO. POKEPOP ASSEMBLY	A2
SCALE:1:1	

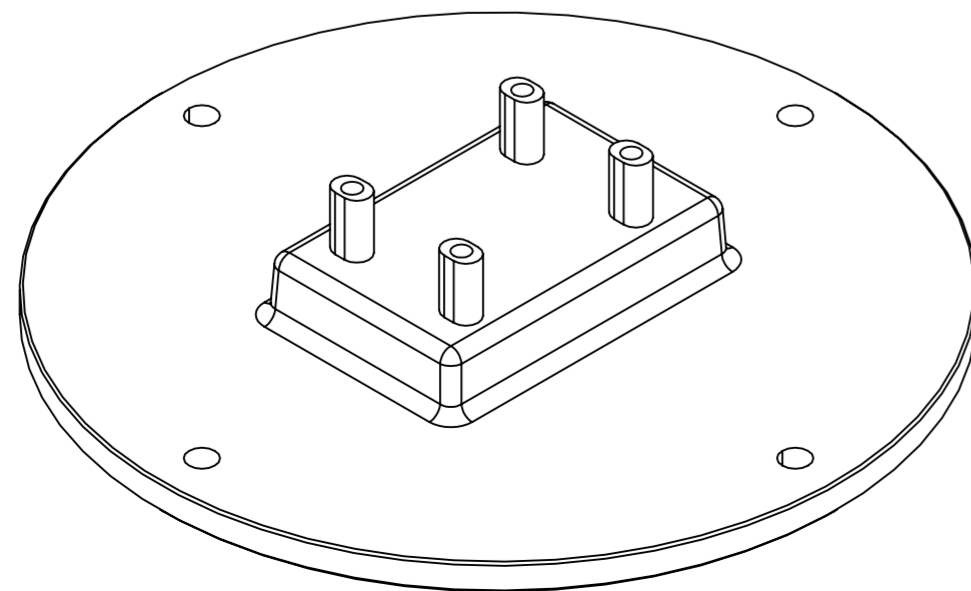
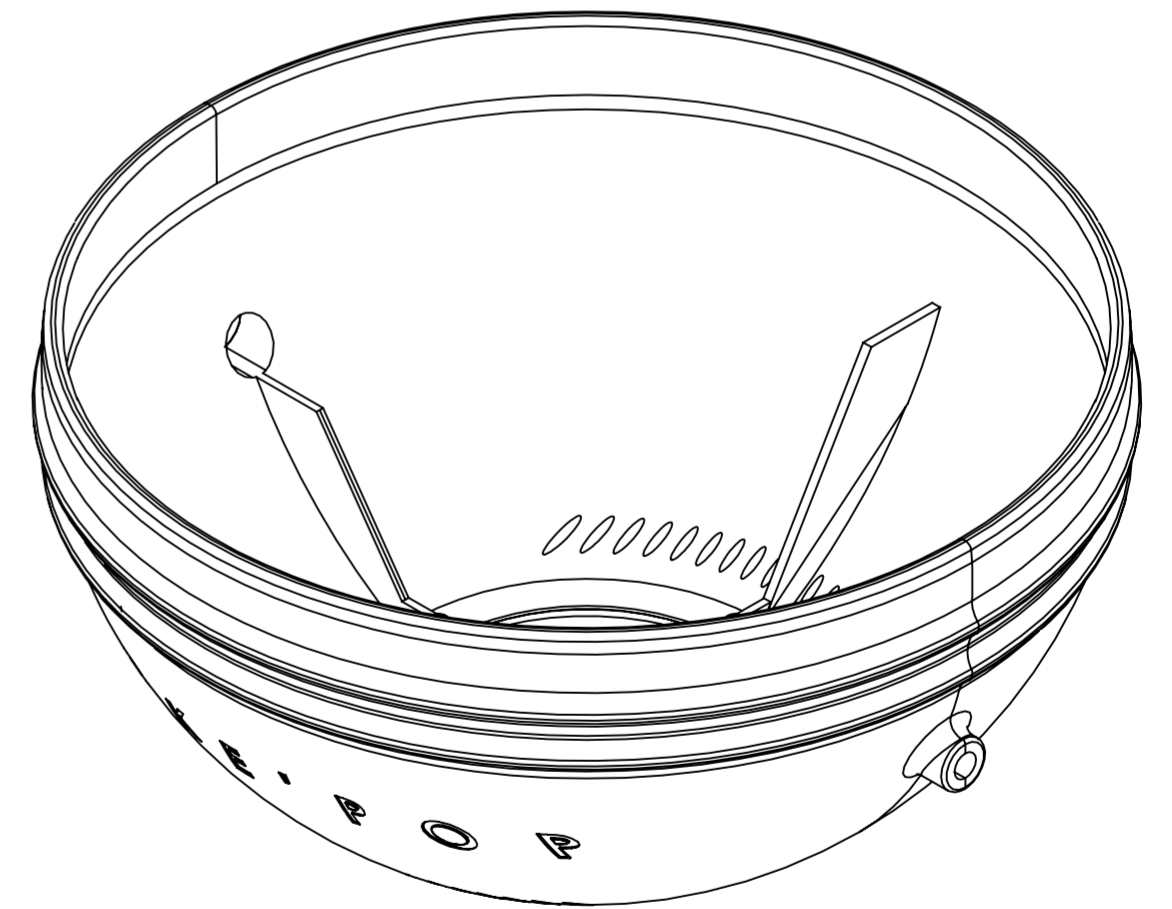
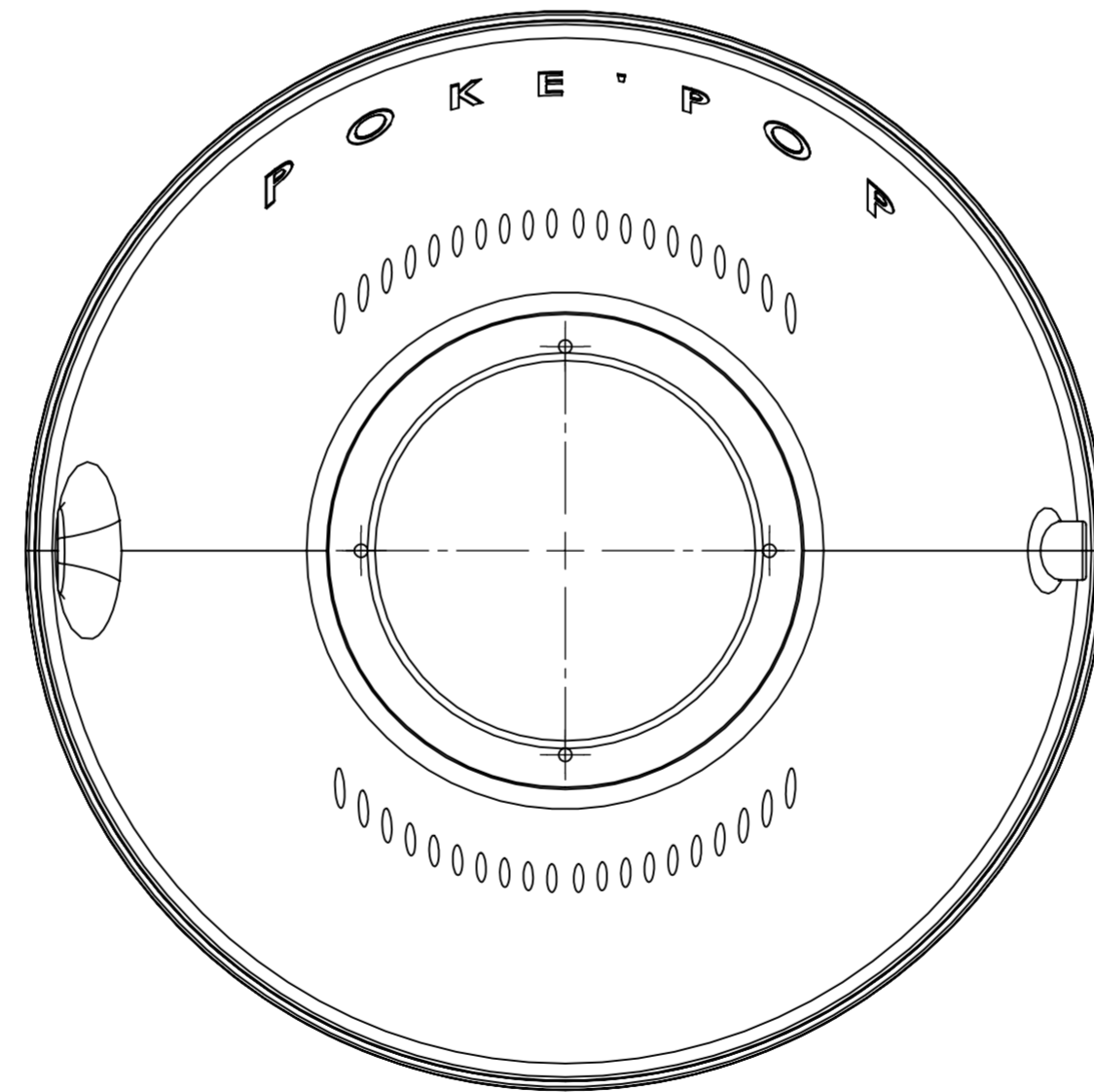
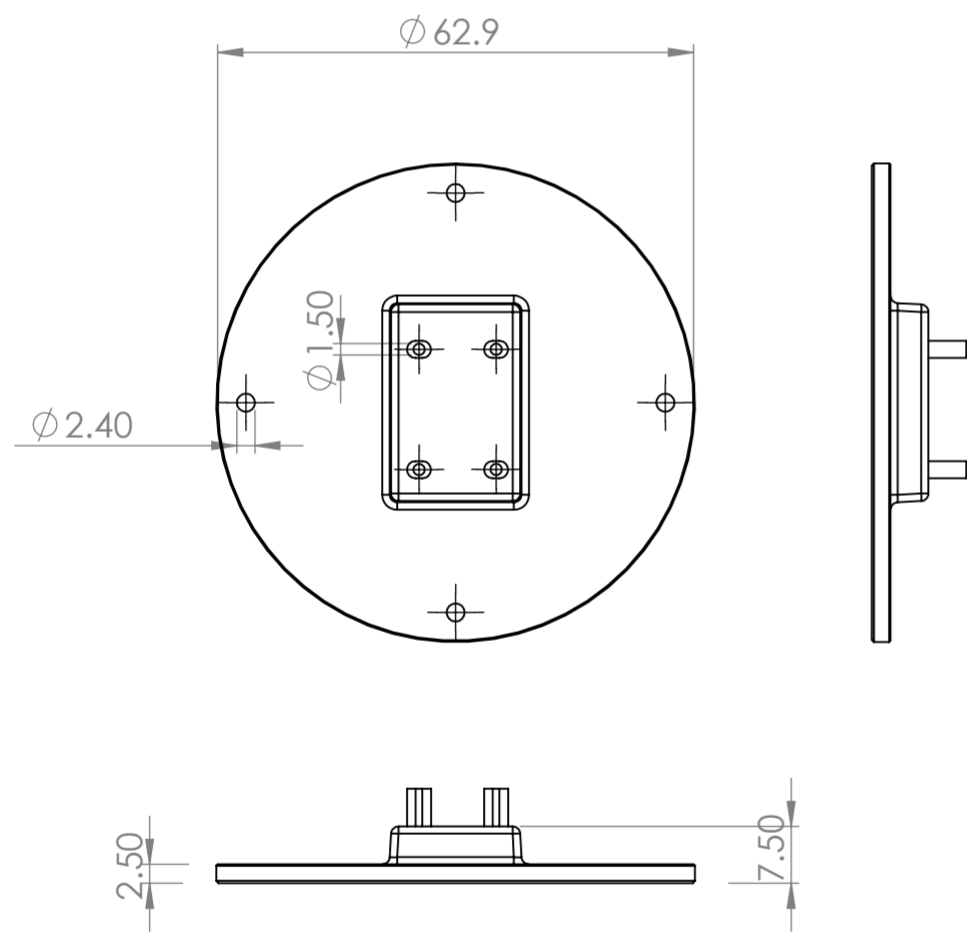
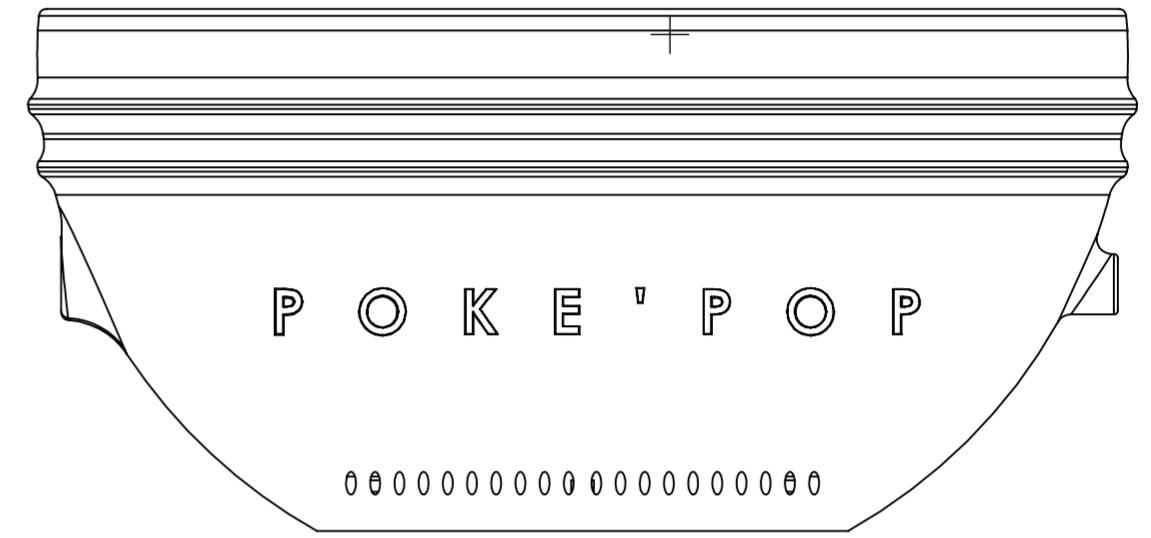
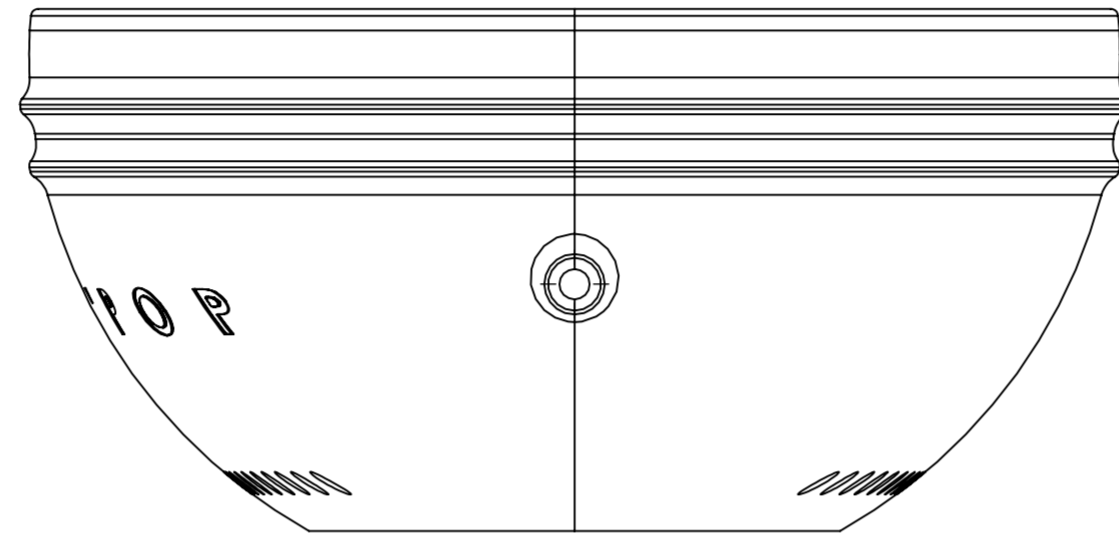
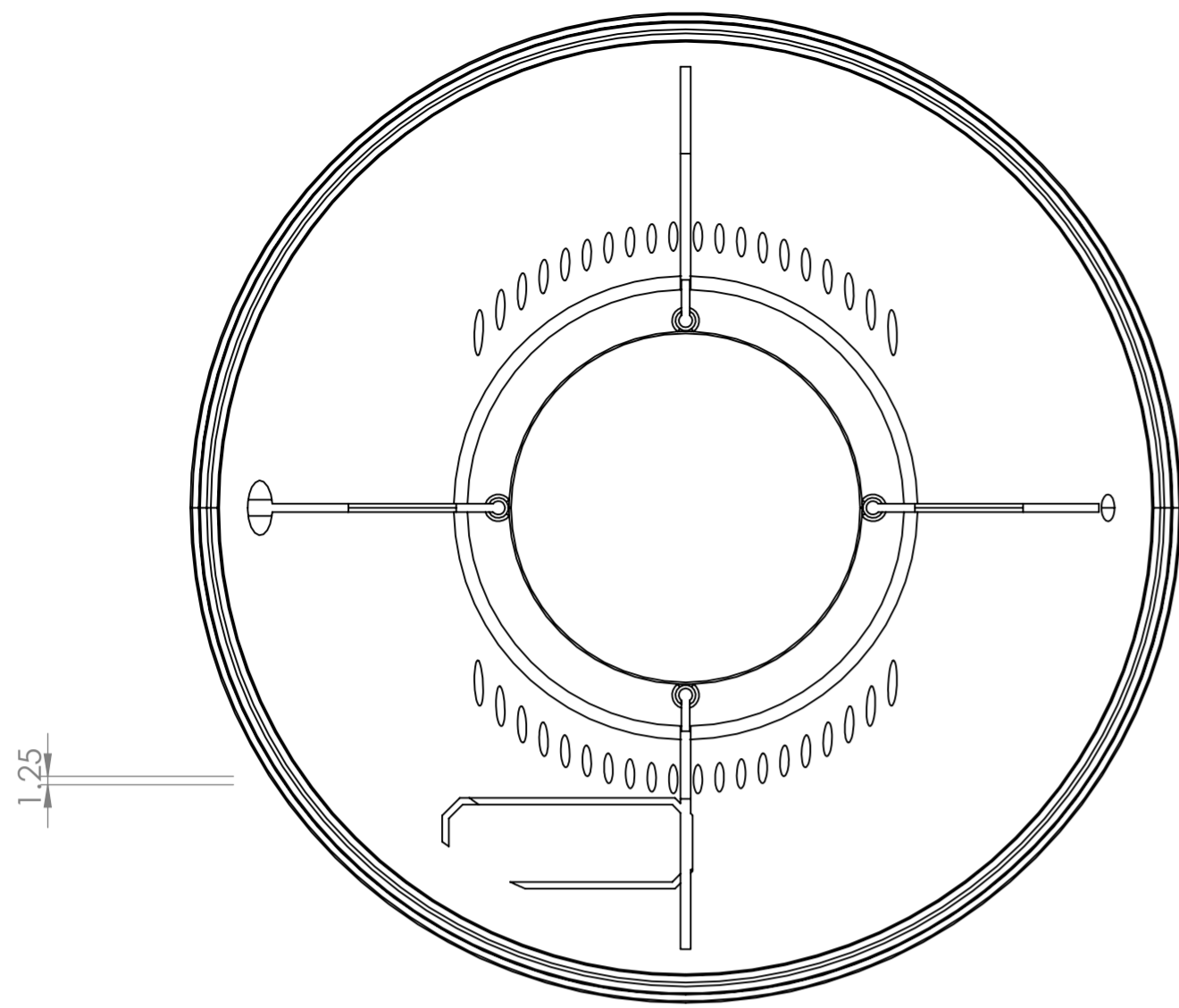

DO NOT SCALE DRAWING	REVISION
GROUP 4	
TITLE: BOTTOM SHELL + CAP	
DWG NO. POKEPOP ASSEMBLY	A2
SCALE:1:1	

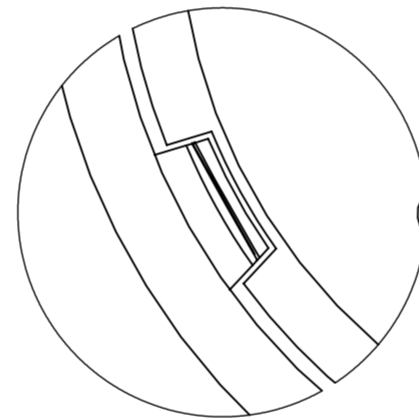
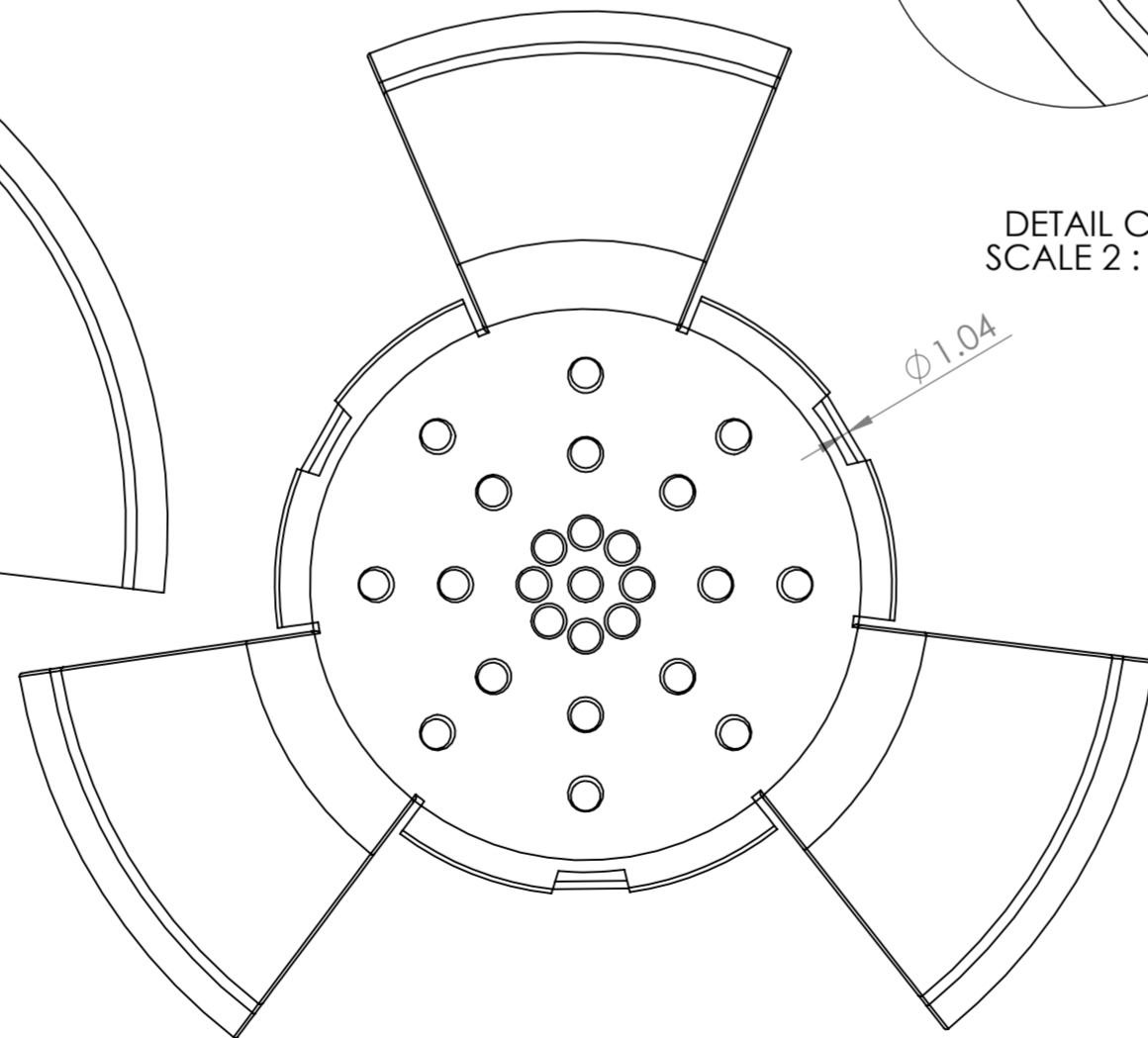
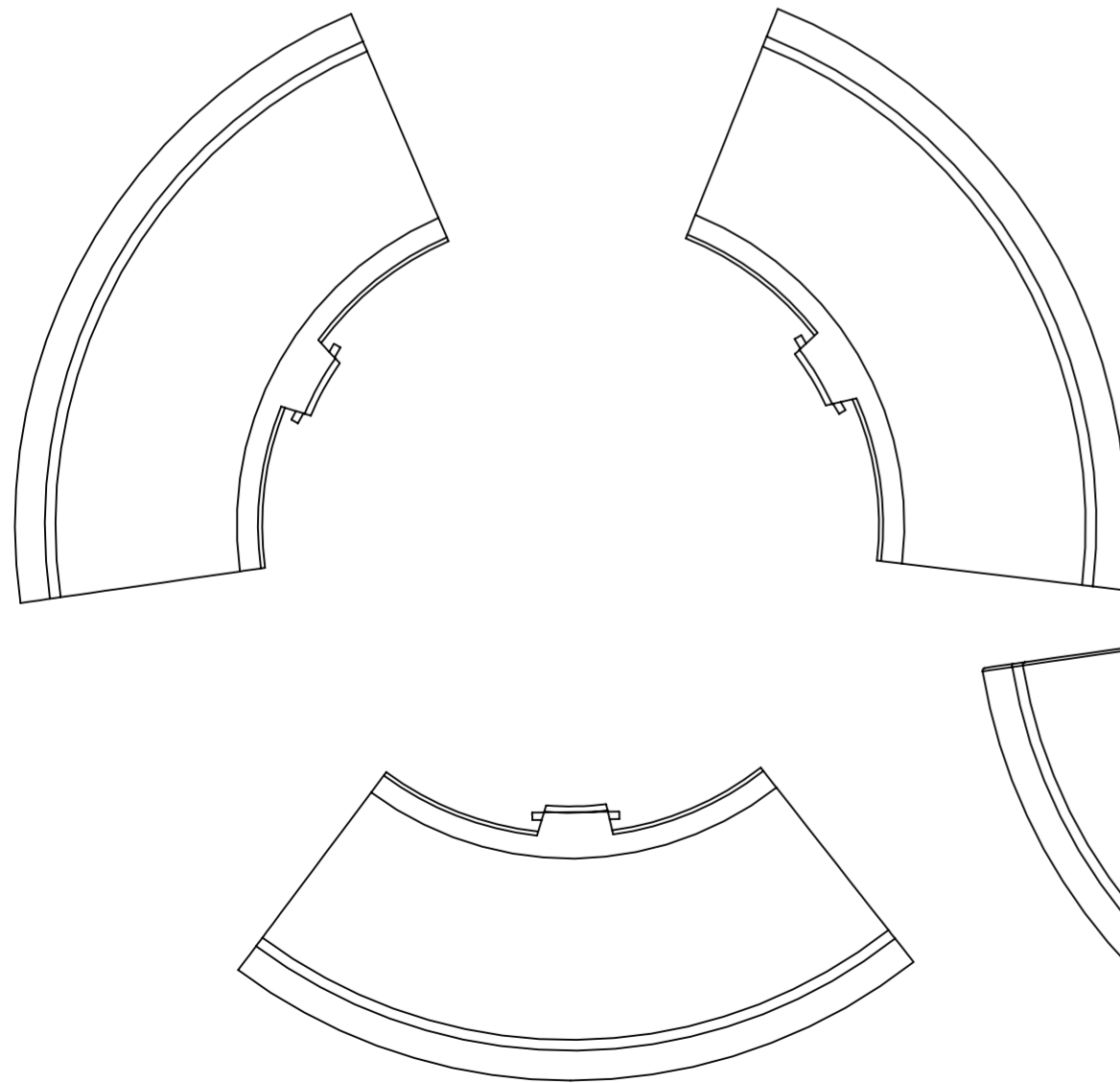
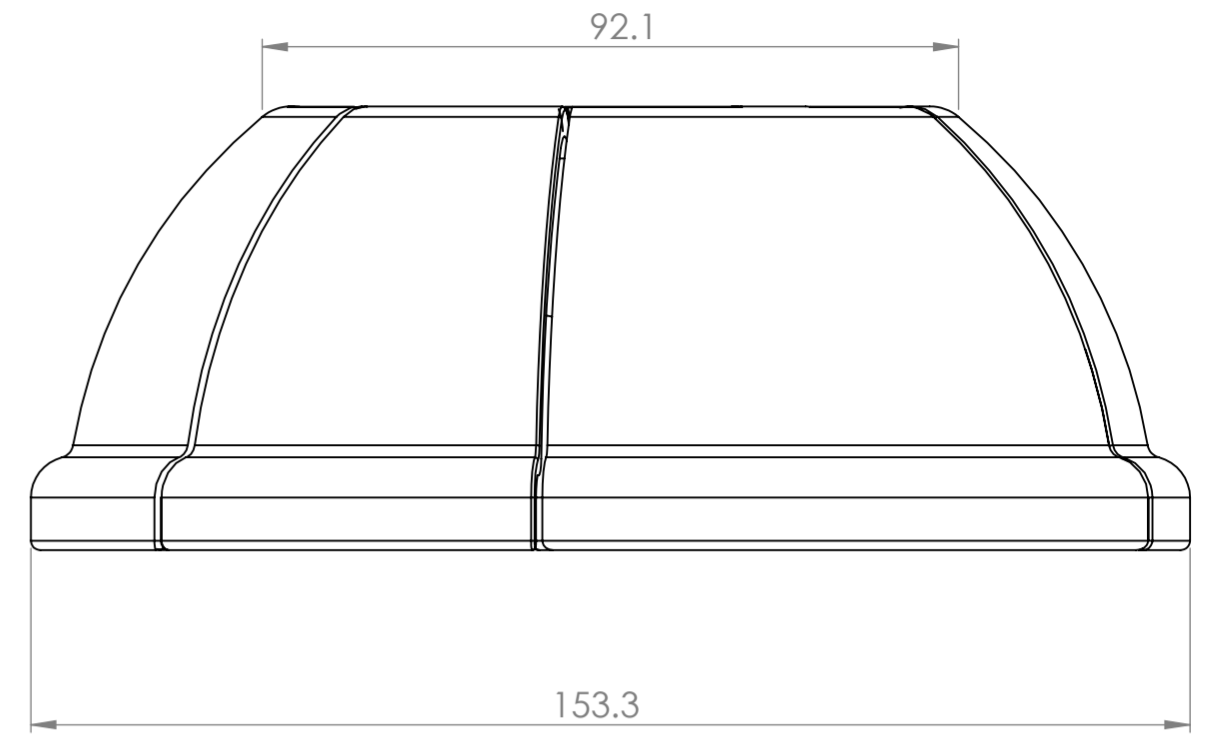
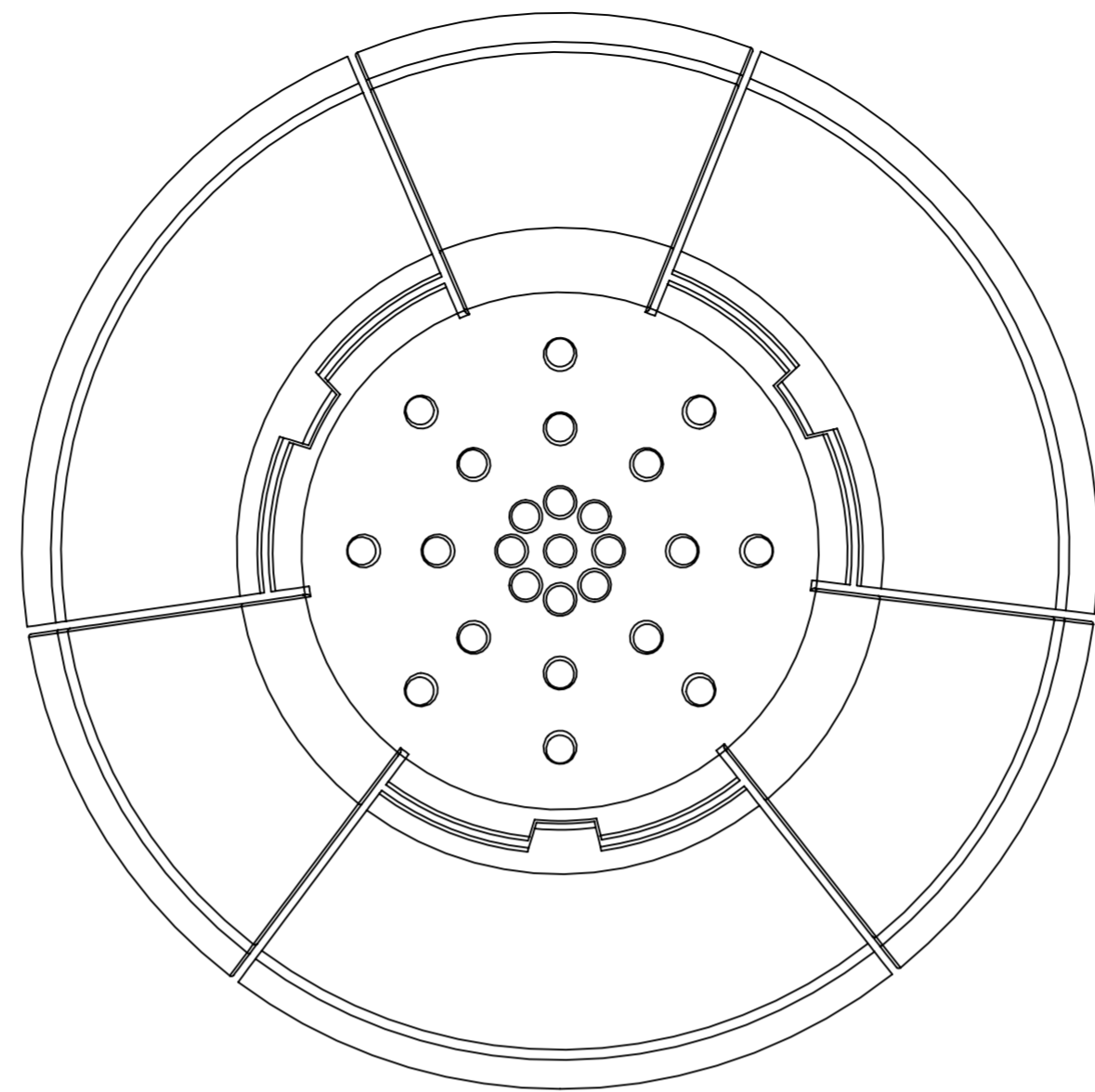
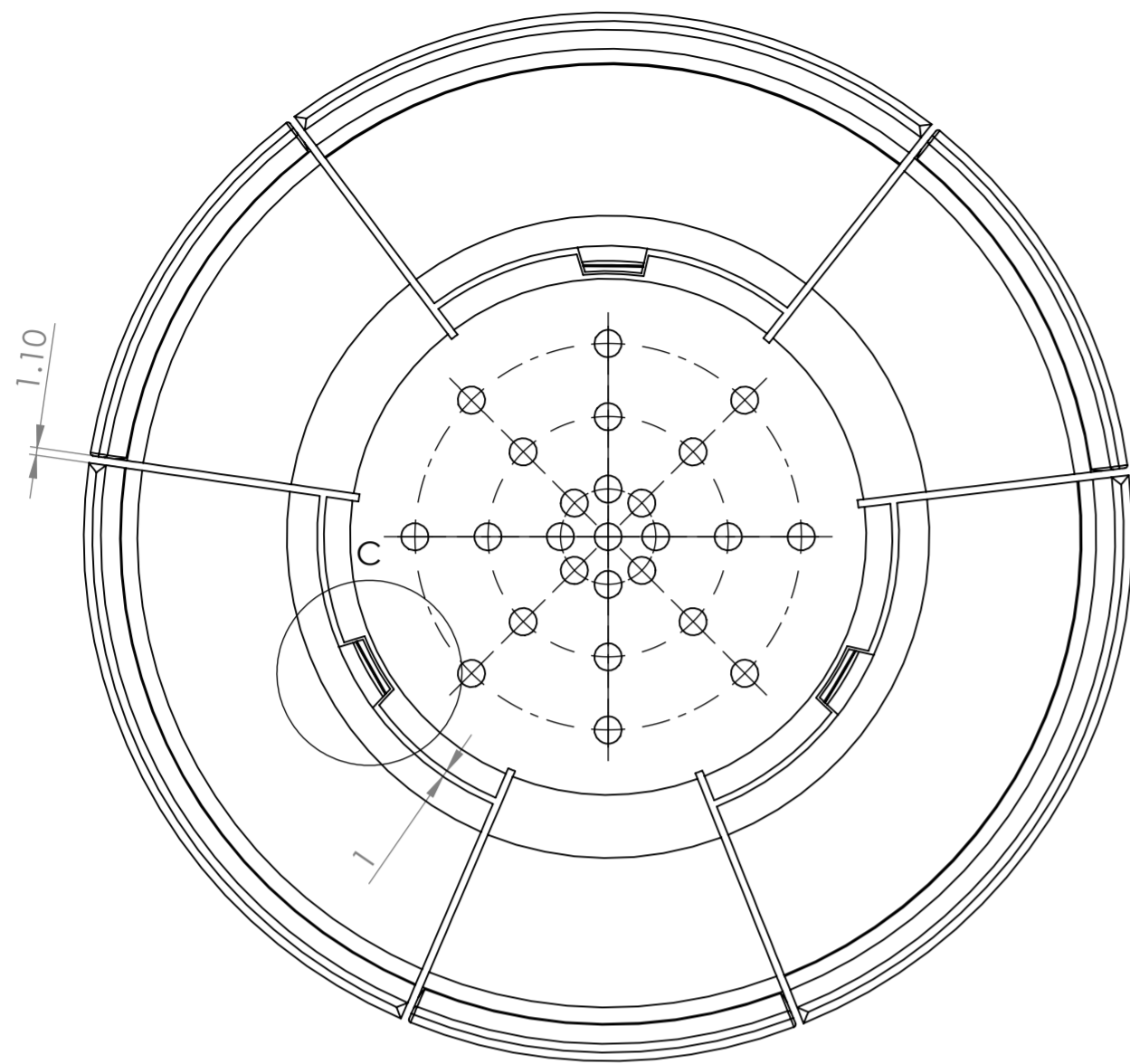

DETAIL C
SCALE 2:1

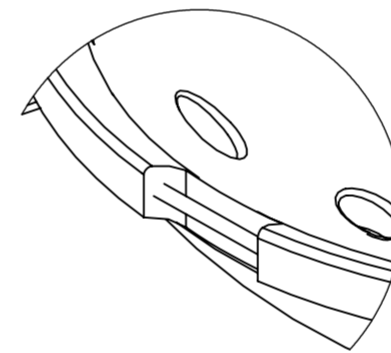

DETAIL B
SCALE 2:1

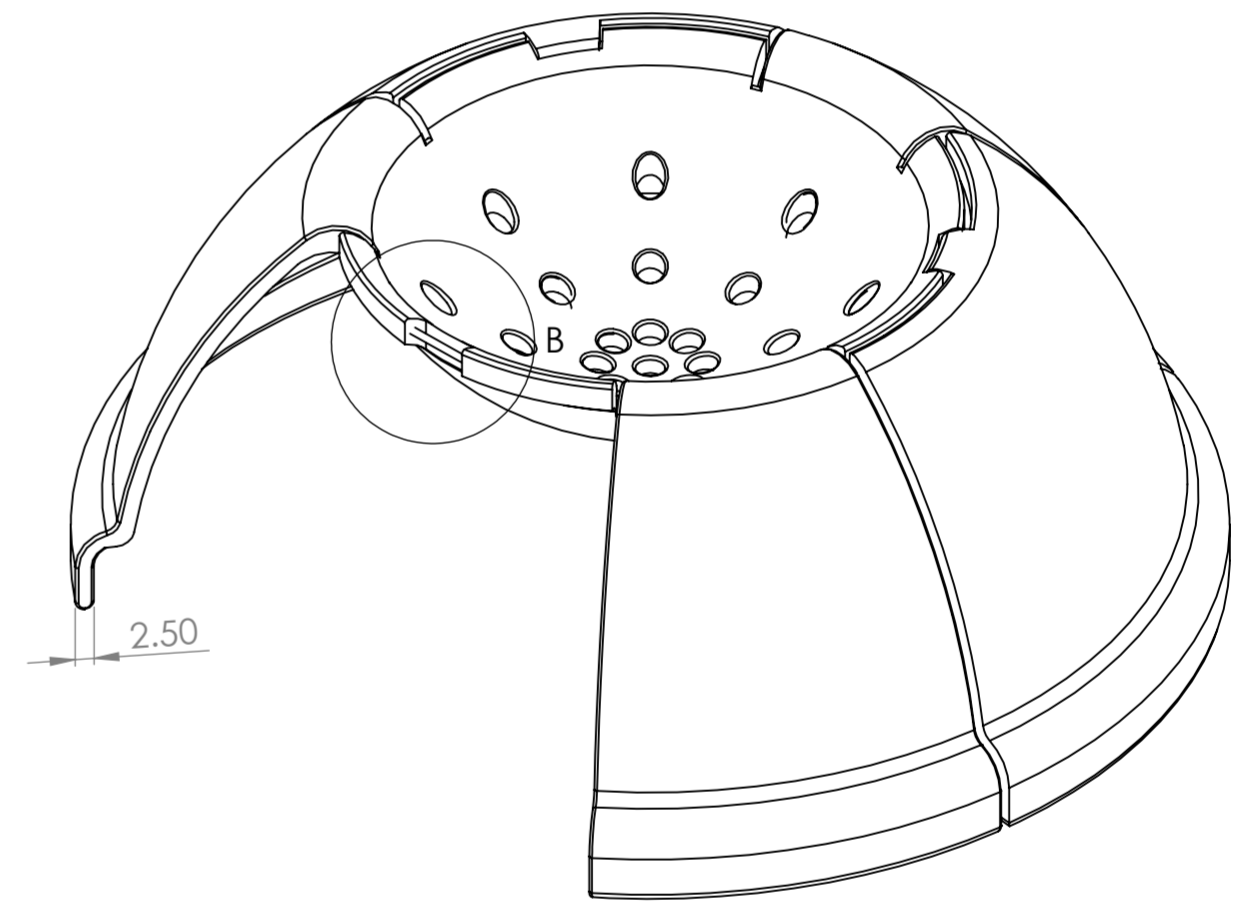

DO NOT SCALE DRAWING	REVISION
GROUP 4	
TITLE: FLAPS + COVER	
DWG NO. POKEPOP ASSEMBLY	A2
SCALE:1:1	

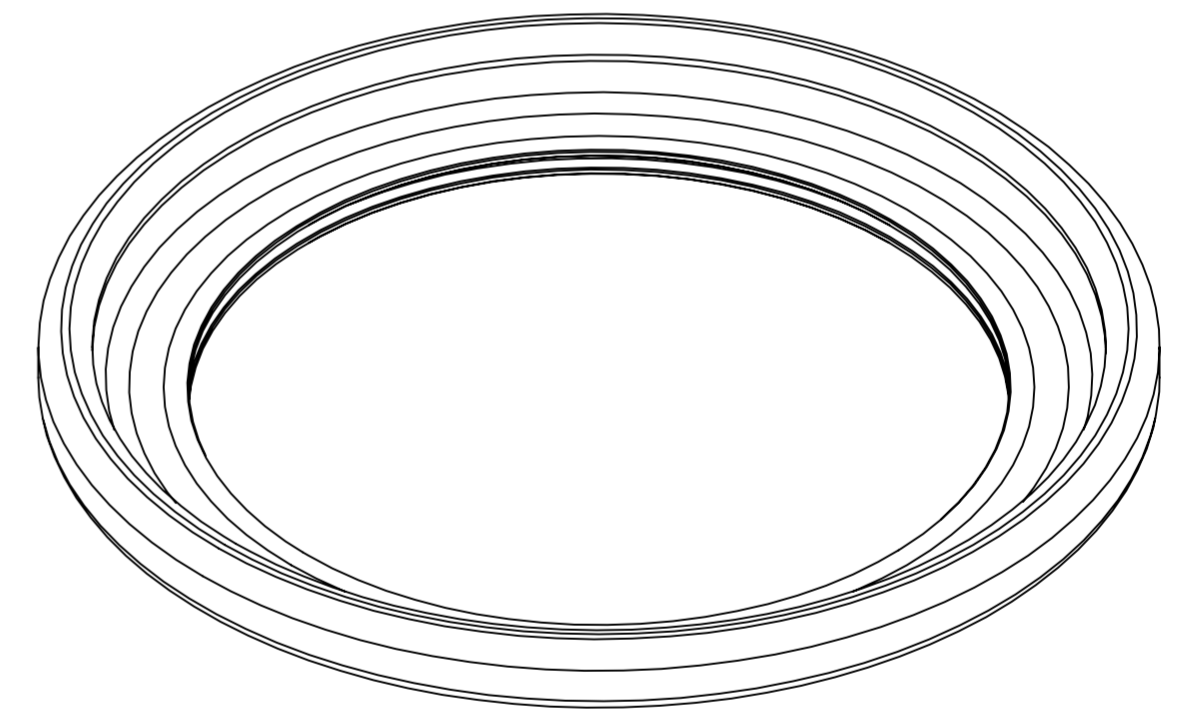
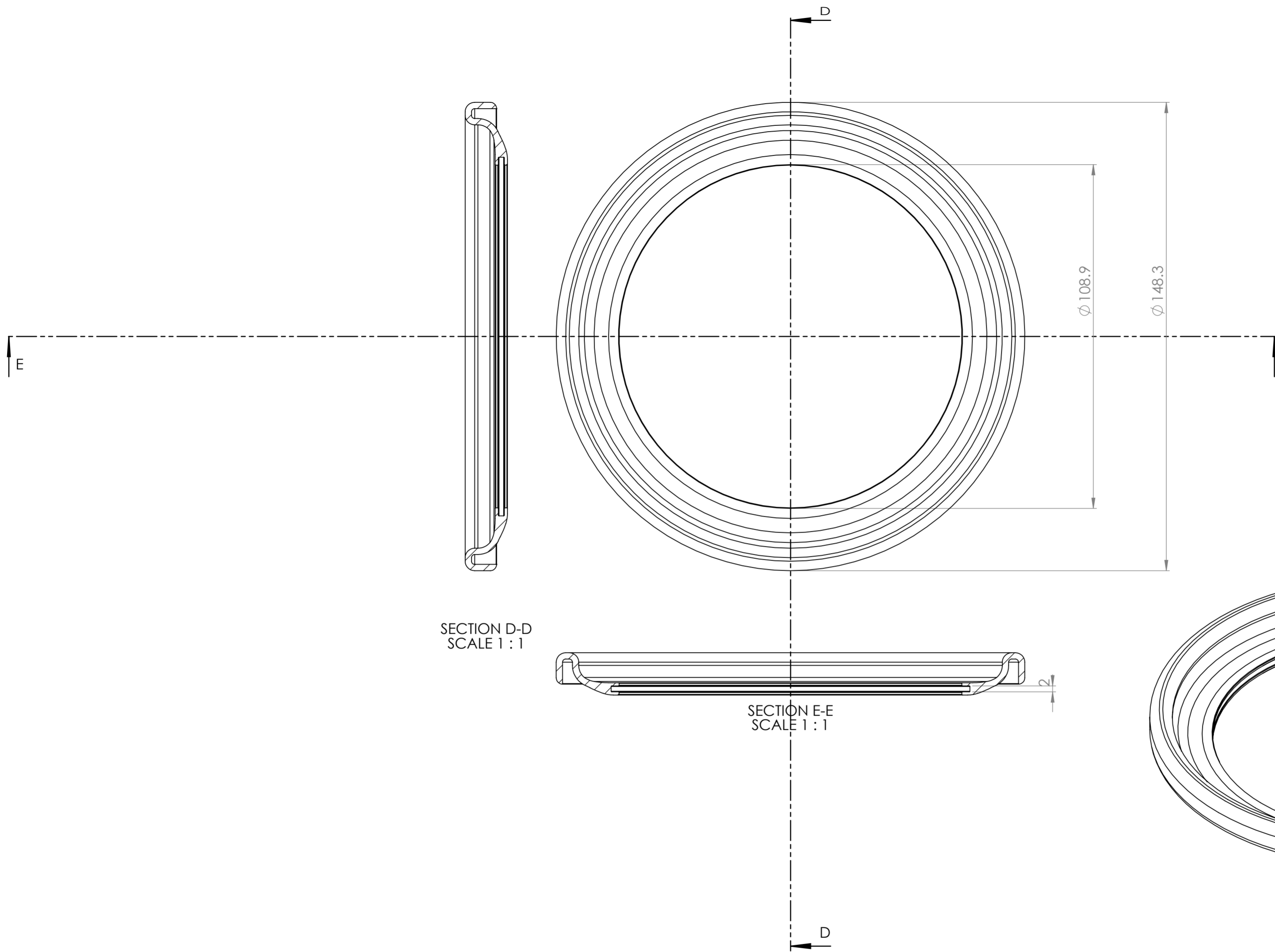

DO NOT SCALE DRAWING	REVISION
GROUP 4	
TITLE: SILYCONE MOUNT	
DWG NO. POKEPOP ASSEMBLY	A2
SCALE:1:1	

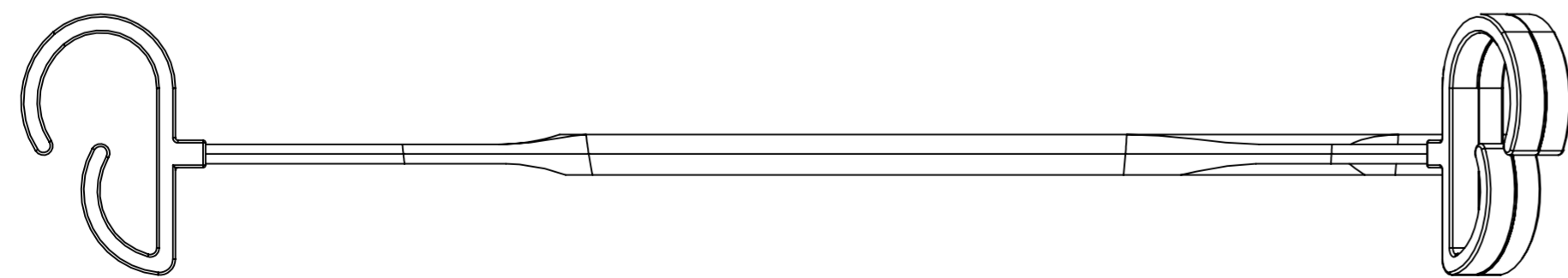
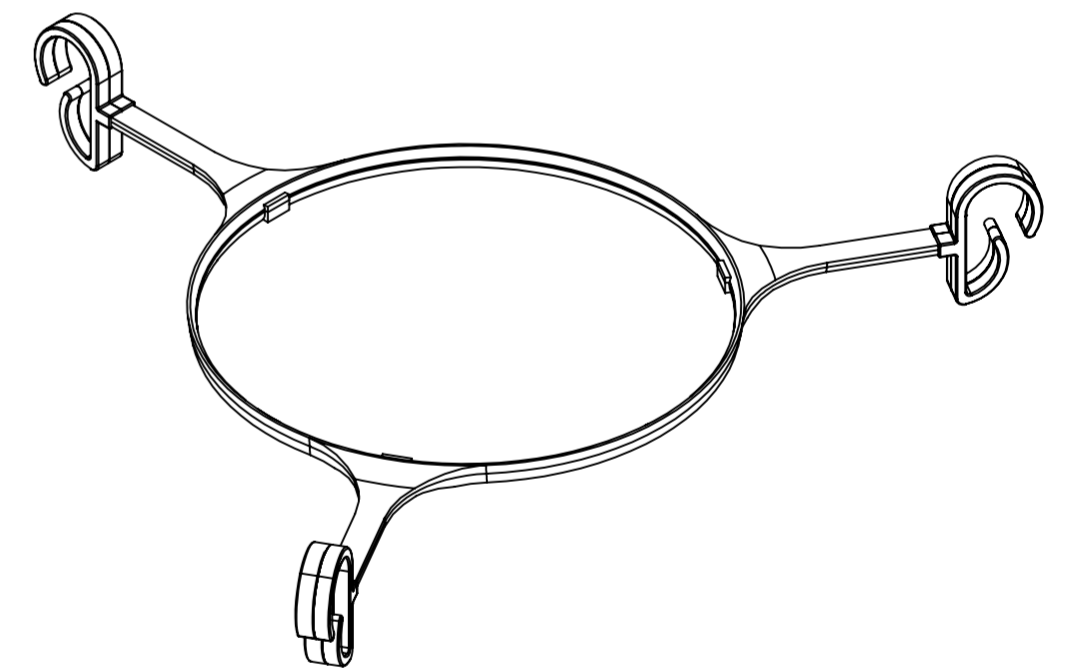
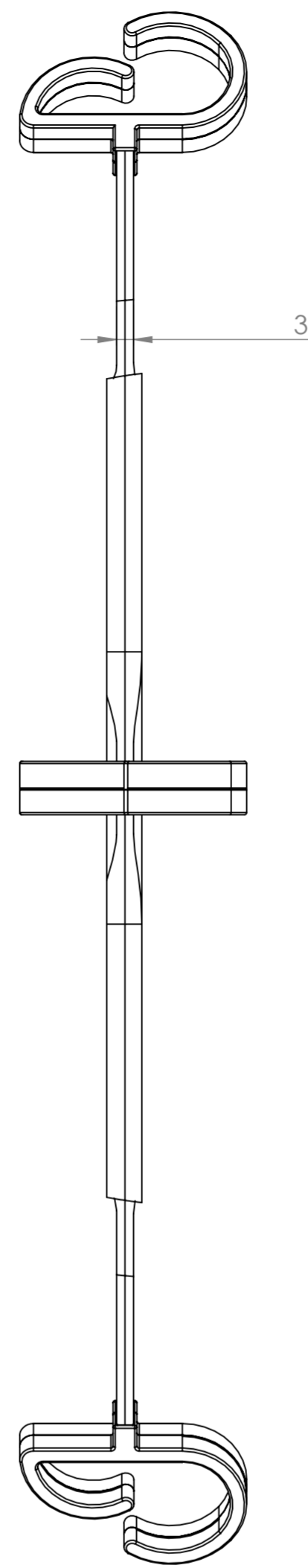
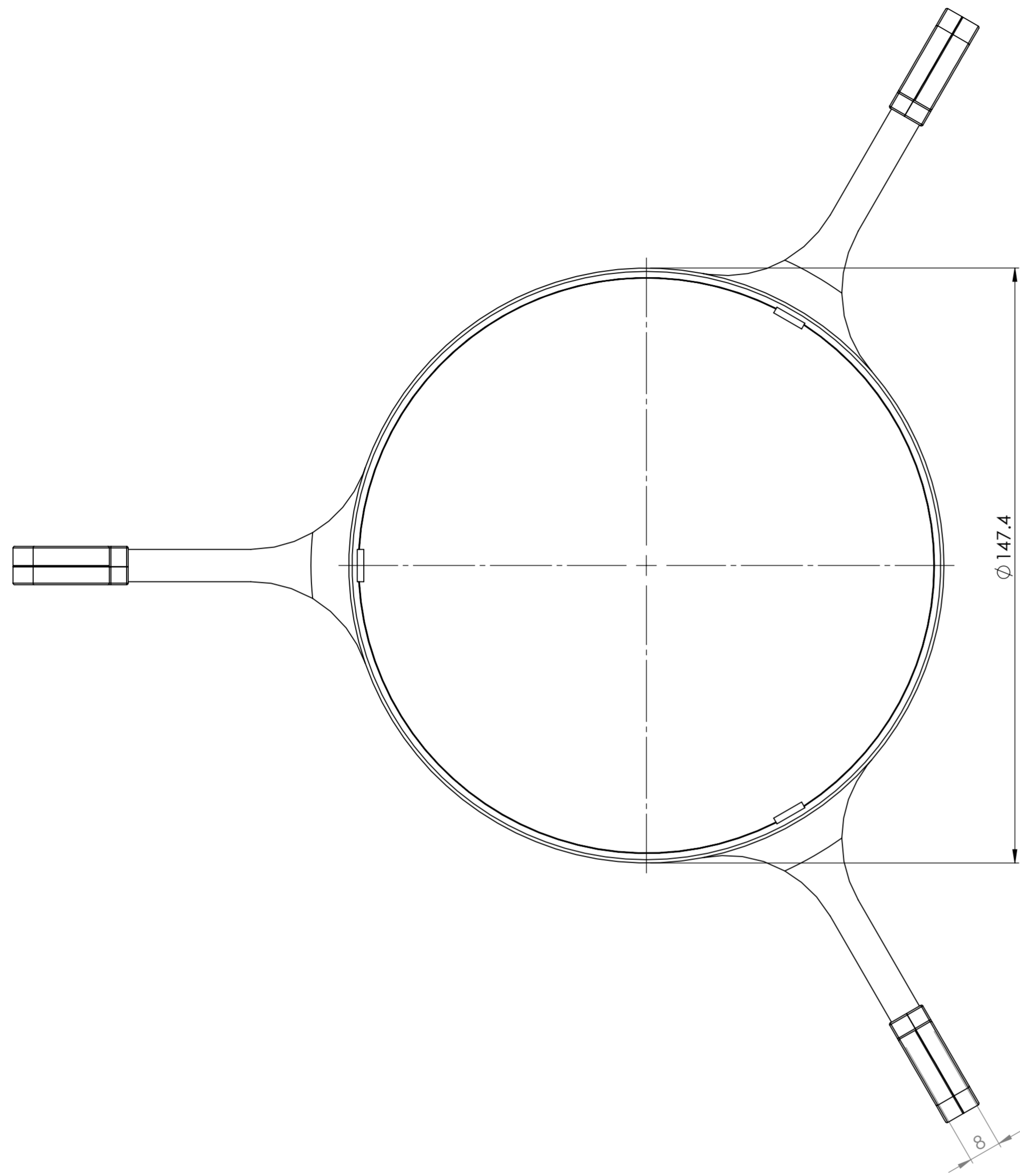

DO NOT SCALE DRAWING	REVISION
GROUP 4	
TITLE: BAND + CLAW	
DWG NO. POKEPOP ASSEMBLY	A2
SCALE:1:1	