

# 2021 PORTFOLIO

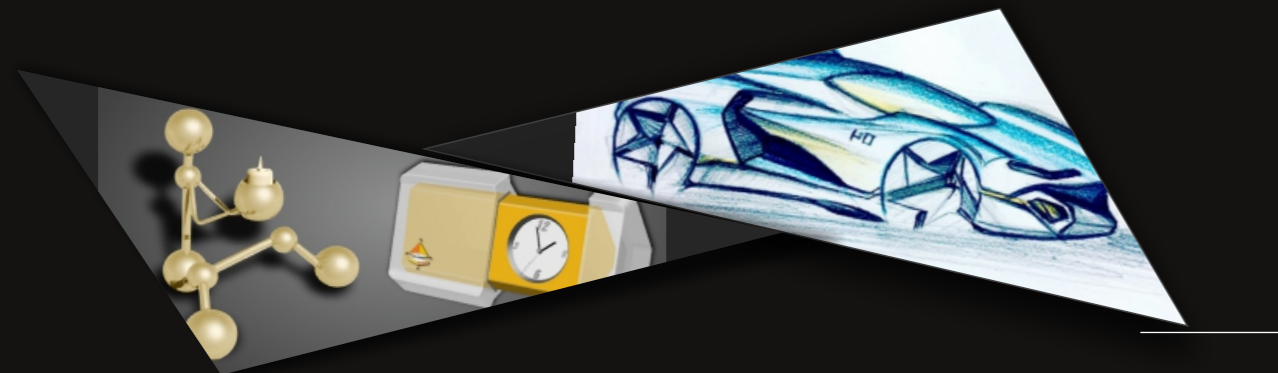
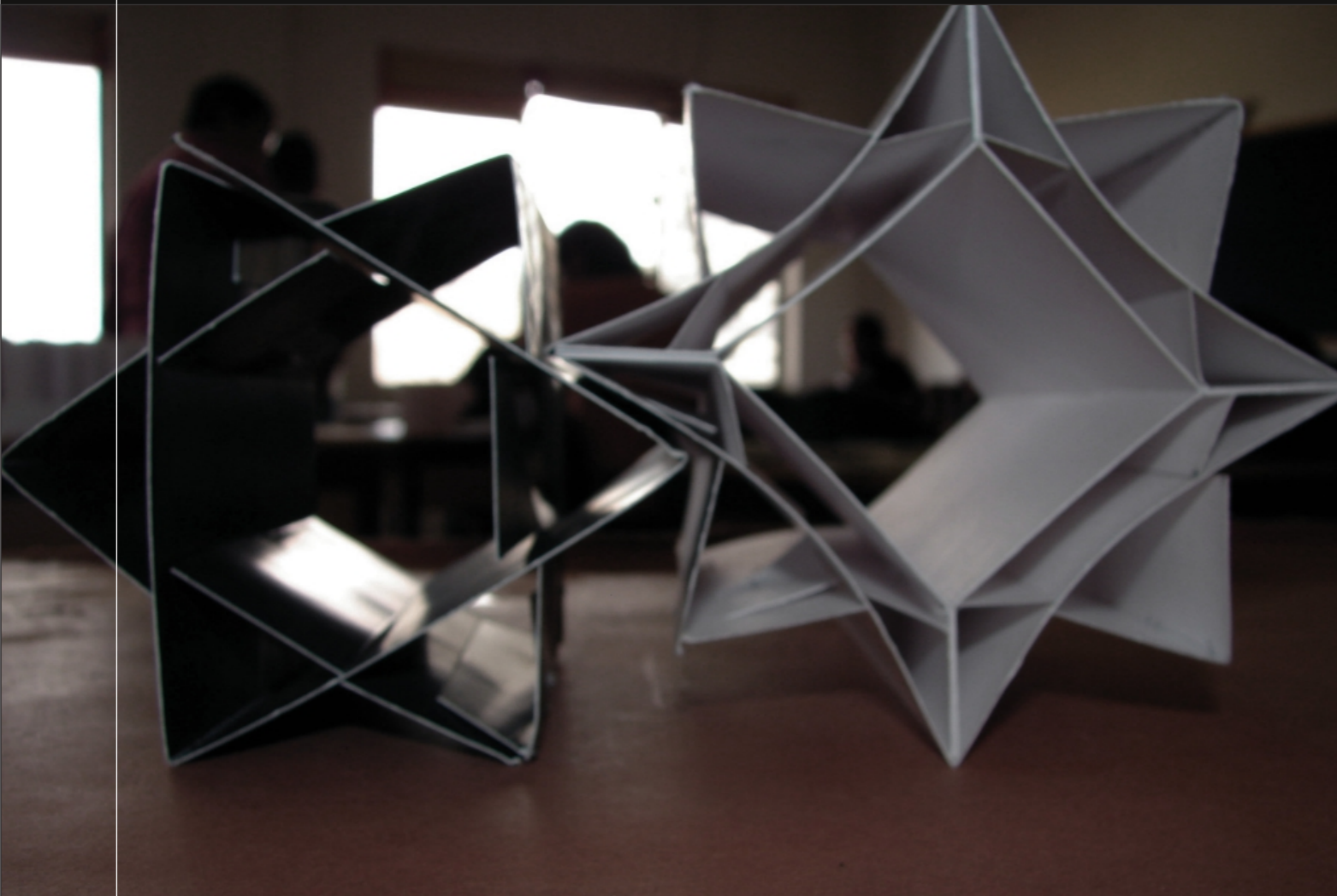

## CURRICULUM VITAE

### WORK EXPERIENCE

#### Hi-Tech Robotic Systemz LTD.

##### Industrial design trainee

March 2009 - September 2009 | Gurgaon, India After graduation, Worked on a project Humanoid Robot NEEL-2 and built to resemble the human body & characteristics.

- worked closely with Industrial designers and technical team, to meet the technical specifications and boundless creativity in a time frame.

- responsible for the overall development and delivery of design through engineering, prototyping, & manufacturing documentation.

#### Pinnacle works

##### Senior Designer August

May 2014 - 2020 | Gurgaon, India

The core business of company is in co-operate gift Sector. I worked on Product design management, material optimization, cost reduction, conceptualization, material selection, design evaluation, rapid prototyping, project presentation and documentation.

- As a senior designer lead my responsibilities including design and co-developing technical products for aggressive timeline.

- Designed a wide variety of keystone have gone on to achieve success as innovative products in the marketplace. managed projects through all phases of design cycle including Brainstorm, initial concept sketches, presentation rendering, supervising prototype, guiding design through the technical phase and provided design attribute to the sales team.

- focus on improved performance at all price levels while maintaining exciting aesthetics of products.

#### The Rhino India

##### Senior Designer

January 2011 - February 2014 | Delhi, India

- As Lead designer, i responsible for creative idealization and execution of point of purchase and merchandising systems by creating a solid foundation to the design process with strategy that takes into consideration the scope of the project, market, timelines, and budgets.

-Coordinate designer, print and graphic designers to meet project requirements and deadlines while fostering a good work environment and help them grow professionally.

#### Stusioideate & Trendesign LTD.

##### Freelance Designer

September 2009 - December 2009 | Delhi, India

As a freelance designer, I have worked with various medium and small businesses in projects of product, packaging, and graphic design. The experience obtained in the past 1 years have provided me with a strong eye for design and set of skills that allow me to visualize each project from the management perspective to the continuous interaction with diverse clients and suppliers in order to meet each project's deadline.

- Deliver various design to clients including market research, competitive/user analysis, rapid ideation sketching, 2D/3D rendering, prototypes, packaging and branding.

### INTERESTS & ACHIEVEMENTS

Participated in Design Summit Emerging Economies (MWF) organize by Center for Knowledge Society (CKS) in March 2017.

- On common platform, we worked with artists and designers from 52 country on specific Indian culture theme.

Participated in Design Awareness-cum-Design Clinic workshops on furniture products in Delhi conducted by National Institute of Design (NID) in September 2007.

- Explore possibilities of wooden joint like dovetail joint finger joints ....

- Different properties of woods and wood steam bending...Participated in three days photography workshops by School of Fototechnik got 2nd position for CLICKING CANDID 2006..

- explored shads of nature, inner perception with shutter speed and aperture Attended the synergies and context 2 day workshop in new Delhi offered by University of arts London in association with RSA in India Explored human body posture and their geometrical structure and transform into spherical and cylindrical shaped innovative products.

- \*\*\* Winner best innovative product at stationery design award 2011.

NASA TECH BRIEF (Feature Design Contest 2007), participated with sustainable and up cycling design concept and collect beautiful product, index finger pen as a recognition gift along with certificate.

### EDUCATION

#### IILM School Of Design

B.Des (Product Design)

August 2005 - August 2009 | Gurgaon, India

10+2 Patna Collage

March 2000 - March 2003 | Patna, India

10th Lotus School

January 1999 - March 2000 | Bihar, India

### SKILLS

Adobe Photoshop CC 2020

Corel Draw X9

Rhinoceros 5.0

Autodesk Sketchbook

Solid works 2015

### PERSONAL SKILLS

UX Design and Design research

Sketching

Ideation / Mind mapping

### LANGUAGE SKILLS

English / Hindi

## BRAND IDENTITY DESIGN

The design of this logo is created solely with the help of typefaces and division of golden space for graphical representation of the business..



SHAKUMBHARI

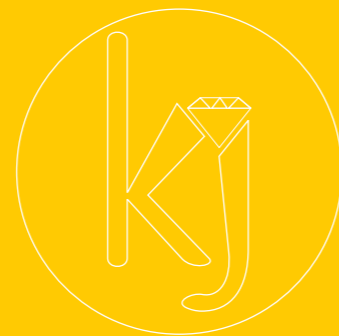

*Kritarth Jewellers*

/3

## PACKAGING DESIGN



A great product needs a top packaging design to help it stand out. We wanted to explore aesthetics of products and their use by observing the user activities with products and the product characteristic.

/4

## PACKAGING DESIGN

Created space for multi-sectional packaging in a single box with visibility of products to improve branding features and audience knowledge.

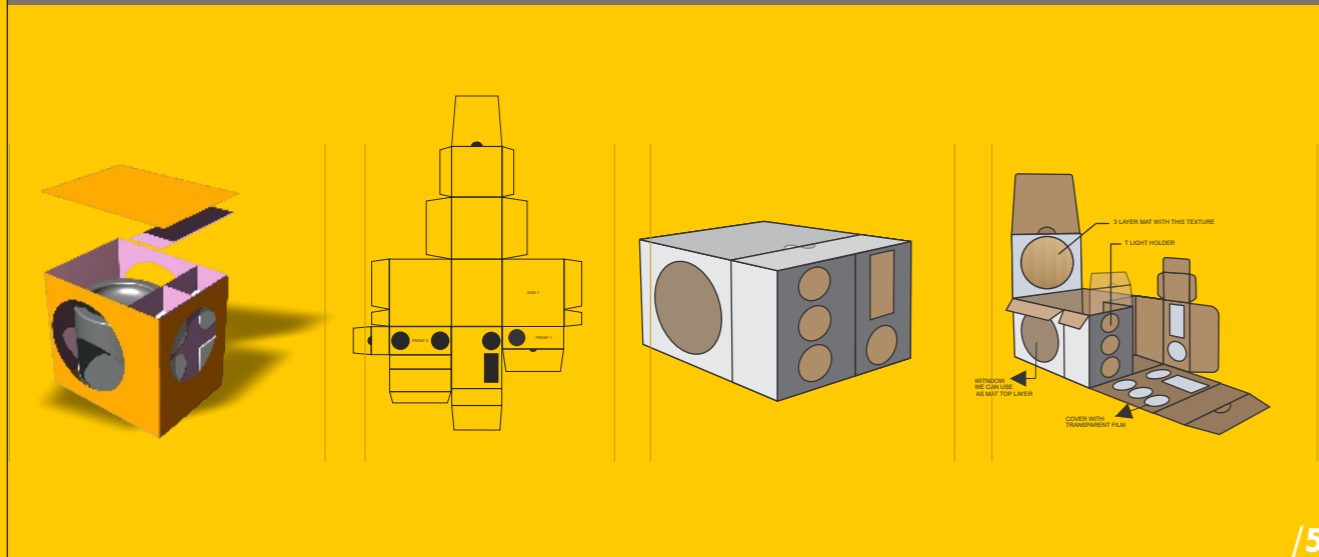

## LIFESTYLE PRODUCT

Describe the relation between human and product by using spheres and cylindrical form of geometry. \*\*\*The Backwards Clock is a clock that ticks backwards, it has backwards numbers and basically does everything backwards...

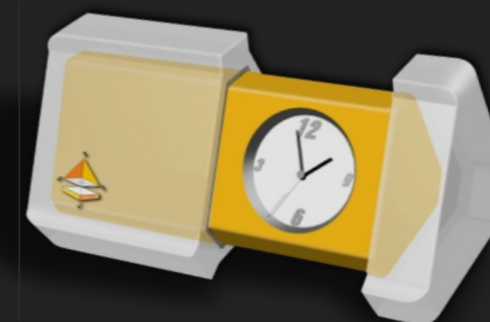

## DISPLAY PRODUCT

Design a modular vegetables display for local market. The basic need of the product is solve the problems during buying or selling of vegetable. Display ergonomically designed in semi circular according to arm reach of seller and The height of the display is according to lower position height of human body.

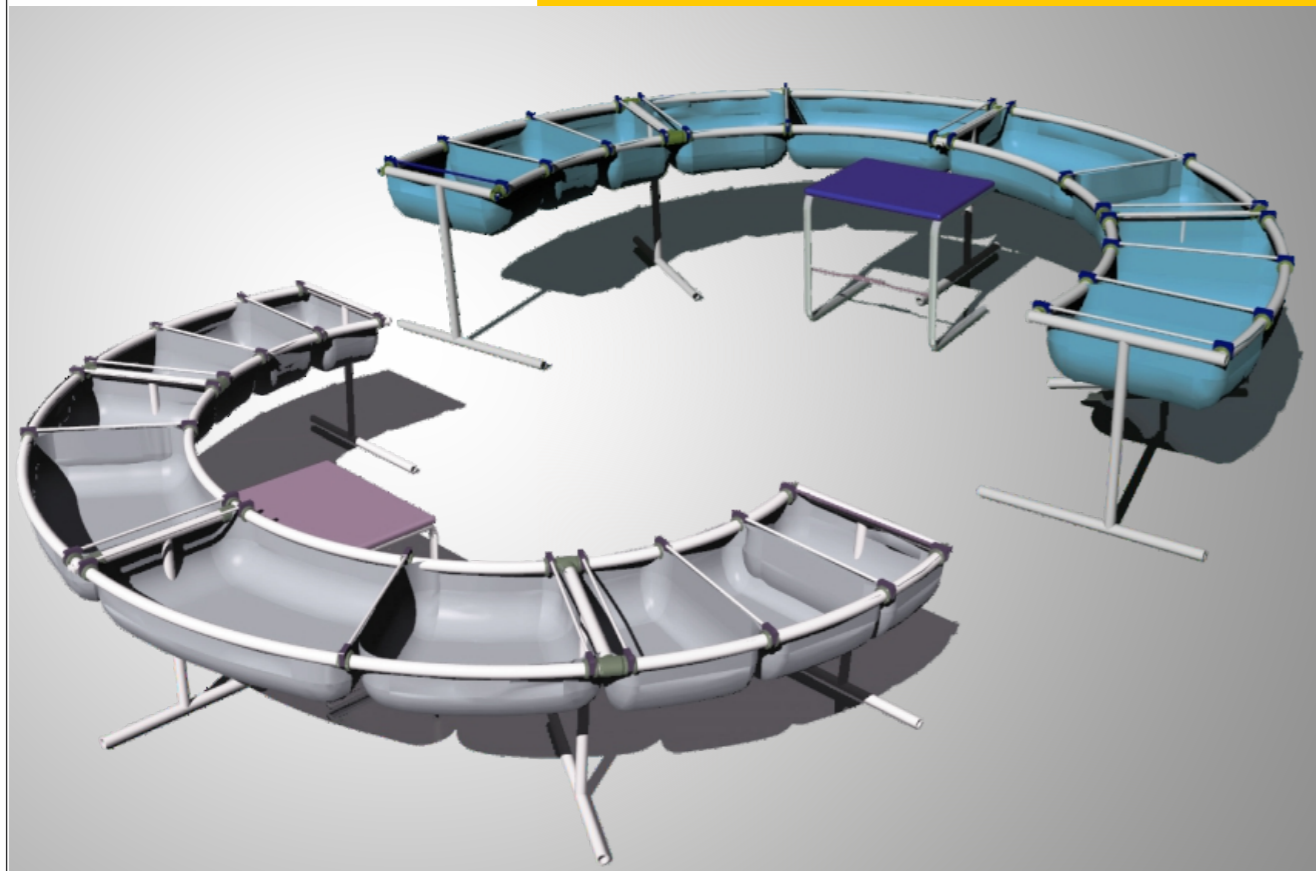

vegetables display



## DISPLAY PRODUCT

Exploded view



Created innovative display to provide take a look at classics and novelties of product line. Developing individual concepts for fitting with an optimal use of space and appealing ambiance. A HPCL lubricant automatic filling station concept, using robotic form and shape. The features, drop light provision for night use and used caster wheels for move to point A to point B..

## DISPLAY PRODUCT

Designed and fabricated acrylic display and dispenser to suit retail sector. The acrylic displays can be used to display all kinds of dry fruits, toffees. Gravity Bin is designed to provide a cleaner way to dispense wholesale merchandise to customers.

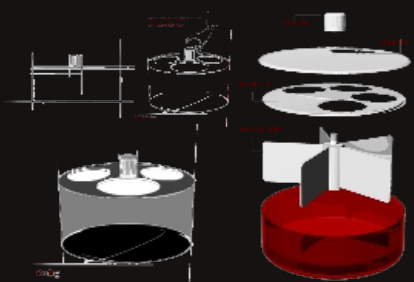
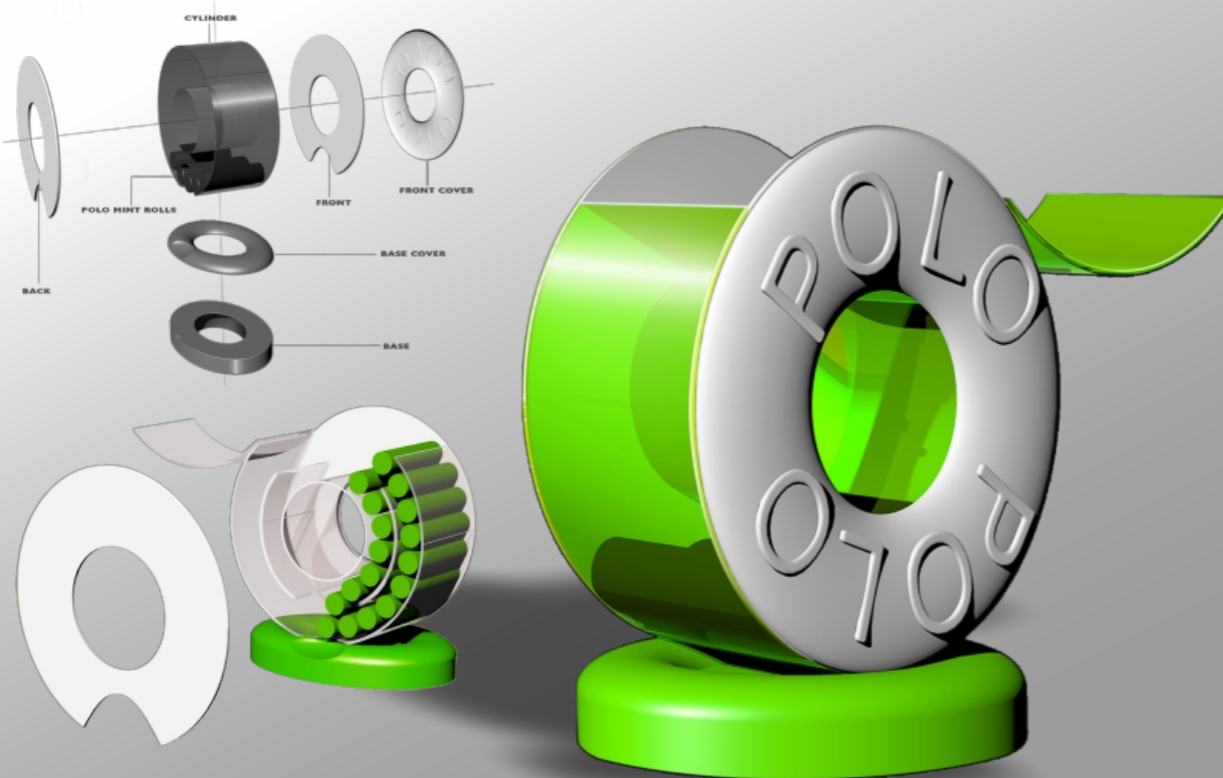

## PACKAGING DESIGN

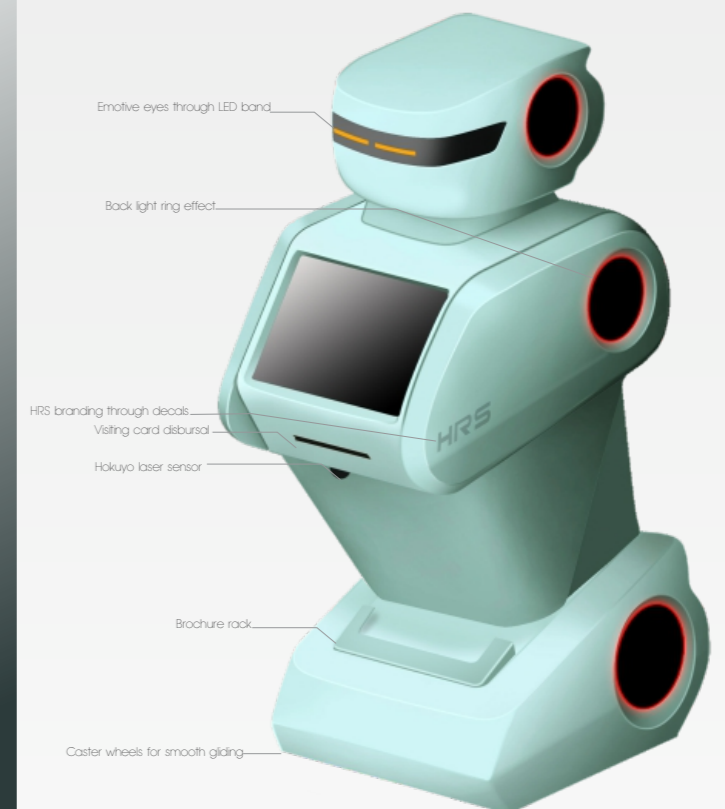

Develop a humanoid robot to make life easier and "interaction between people and robots." Objective of NEEL-2 is display information and user guide in shopping complexes, Mall, events and Exhibitions.

## DESKTOP PRODUCT DESIGN

Developed table top pen holder for co-operate sector to keeps works space free of clutter, worked on a theme "Team works" and created beautiful hands together holding pens and pencils. it works as a decorative elements on the desk in offices.



## AWARD DESIGN

Created 3D geometrical shooting star with interactive face on top to depicting success and achievement and team works. "Motion Transformation" transforming the geometrical shape square into triangle with slant motion line. Developed a award with using circular form for structure as well as branding on top and front of trophy depicting motion for motor show.



Created diamond shape structure of human body, which give's premium looks with beautiful colors with graphite matte base.

# BLOOD PACKAGING DESIGN

This design concept includes some smart fixes, such as better labelling of blood types with colours, shape design. 1. Separate the labels and marking area. 2. wide hangers hole to hang in different hanger. 3. Handle to carry the blood bag.

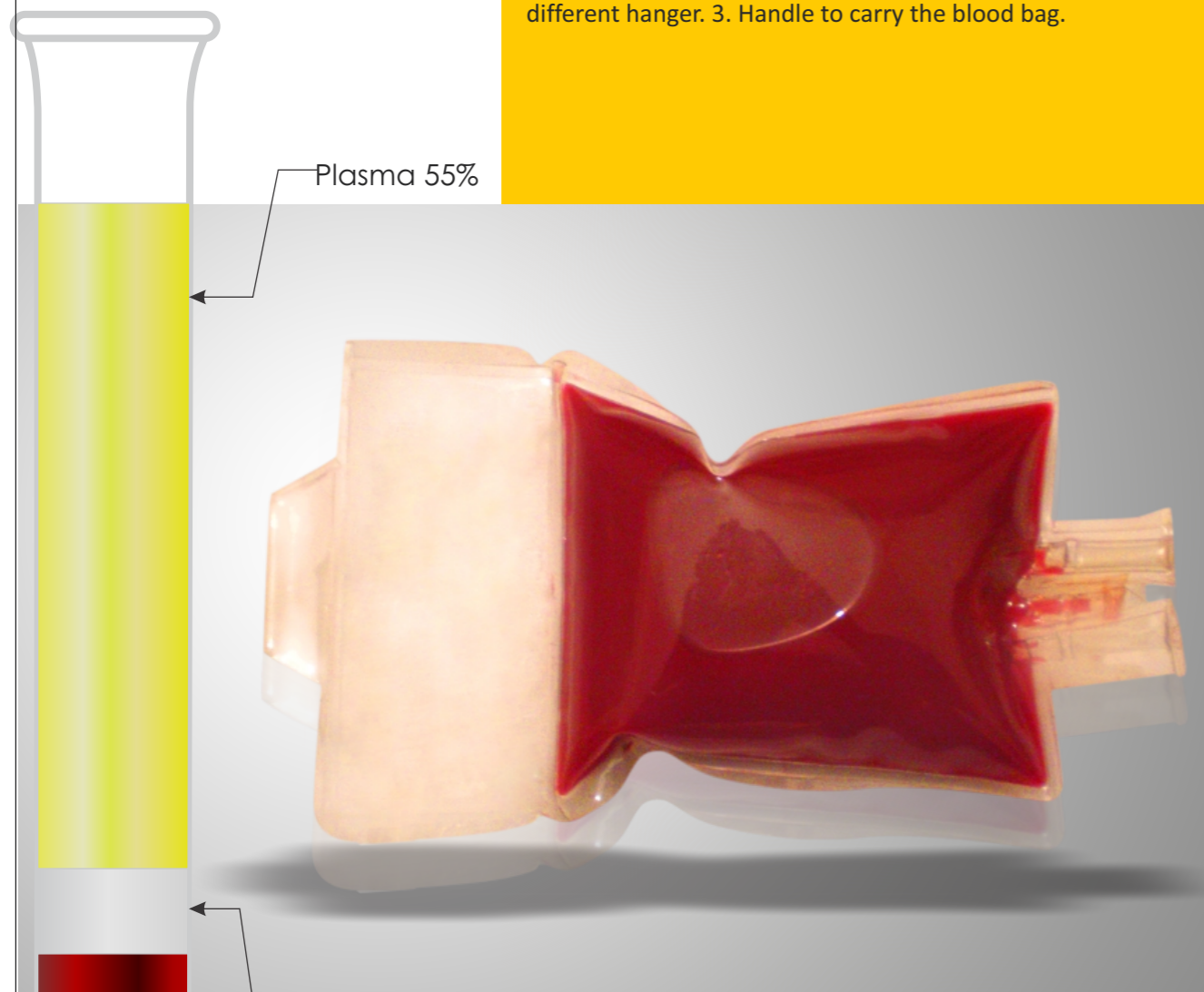

# GEOMETRICAL STRUCTURE

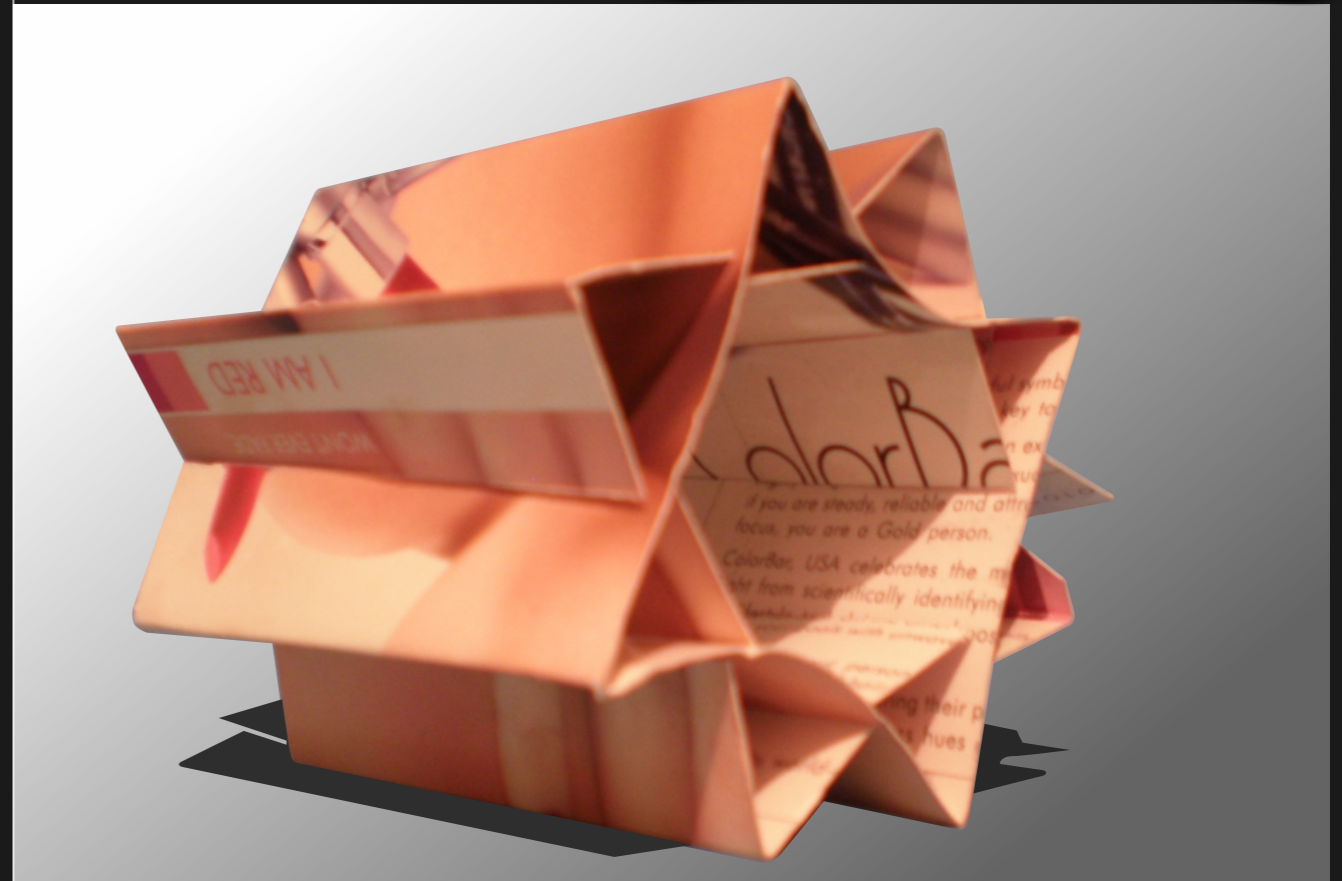

Developed optimal structural design by exploring the structural strength of paper and converted into the Design. Designed and produced on a very minimal lines. Single corrugated paper and crafted into a very beautiful form of hanger. Objective:- Hanger designed to improve the looks of the cloths and display the element of the cloths. The corrugated sheet used for develop the Hanger, which is cheap and easily recycles materials.

# SEARCH LIGHT GRILLE BARS

Integrated and aerodynamic from created of search light guard with 0% sharp. distance between grille bars design by light focus merging reference. grille bars basically design to protect the light components during various condition of military operations in Indian defense.

- FEATURE:
- Protective-grille
  - vertical grille use to reduce obstruction of light
  - Ergonomics
  - storty

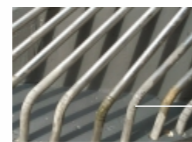

front bend grille to improve straight



# ANGIO SEAL DISPLAY

Design a product to display the 3 major activities of angio-seal during angiography procedures, sandwiching the arteriotomy between a bioabsorbable anchor and collagen sponge.

Objective: Patients can easily understand the sealing procedures, and they will adopt these sealing procedures.

- Anchor: Bioabsorbable co-polymer anchor placed against the inside of the vessel wall
- Collagen: Placed on top of the arteriotomy in the tissue tract
- Suture: Cinches the anchor and collagen together to form a secure seal

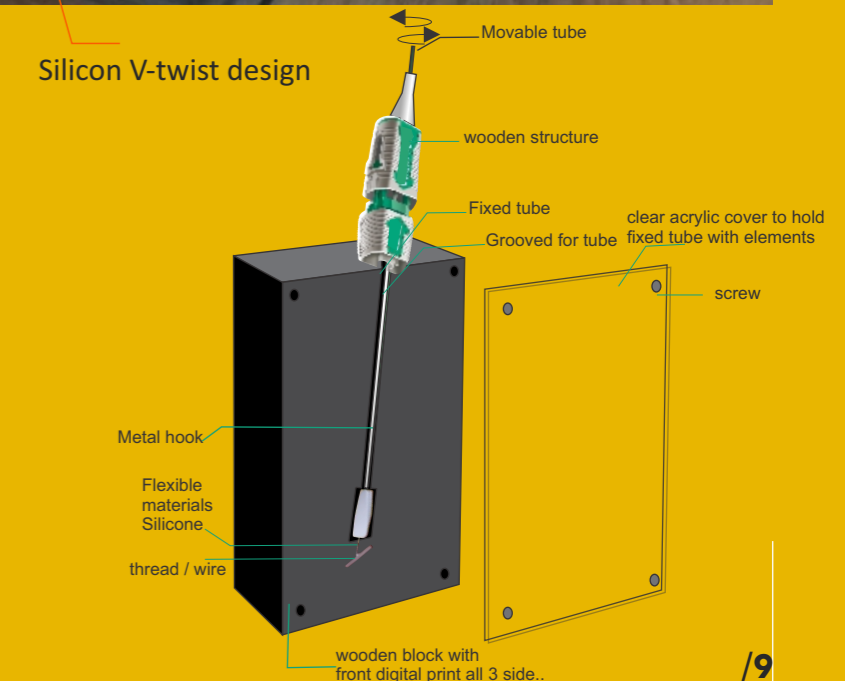





# Thank You

 [ravibhushan.sona@gmail.com](mailto:ravibhushan.sona@gmail.com)

 [facebook.com/ravi.bhushan.7967](https://facebook.com/ravi.bhushan.7967)

 [linkedin.com/in/ravi-bhushan-394bb9a6](https://linkedin.com/in/ravi-bhushan-394bb9a6)

 [ravi.bhushan\\_singh](https://instagram.com/ravi.bhushan_singh)