

OFFWORLD MAN CHARACTERS pt 2



CHARACTER STUDY-- IDRIS ELBA is the
CHARACTER ARCHETYPE for CHET WOLF---



Chief Engineer and Project Manager, Chester “Chet”
Wolf

CHET and GORDON are CO-FOUNDERS and UPPER
MGMT AT OM GROUP AEROSPACE
and BEST FRIENDS

REMEMBER TO ATTACH-

OMA ULTIMATE COLLECTION.pdf

OM 1 SCREEN PLAY.pdf

EDO SUIT ORIGINS.pdf

GMA PARKS CHARACTER STUDY.pdf

EVE 2.0 ORIGINS.pdf



Sofia Boutella - IMDb

Sofia Boutella is an Algerian actress, dancer and model. She was born in the Bab El Oued district of Algiers in Algeria, the daughter of composer and jazz musician Safy Boutella, and a...
Job Title: Actress SoundtrackHeight: 1.65 m



Sonoya Mizuno

Actress · Soundtrack



YOUNG GMA PARKS



OLDER GMA PARKS



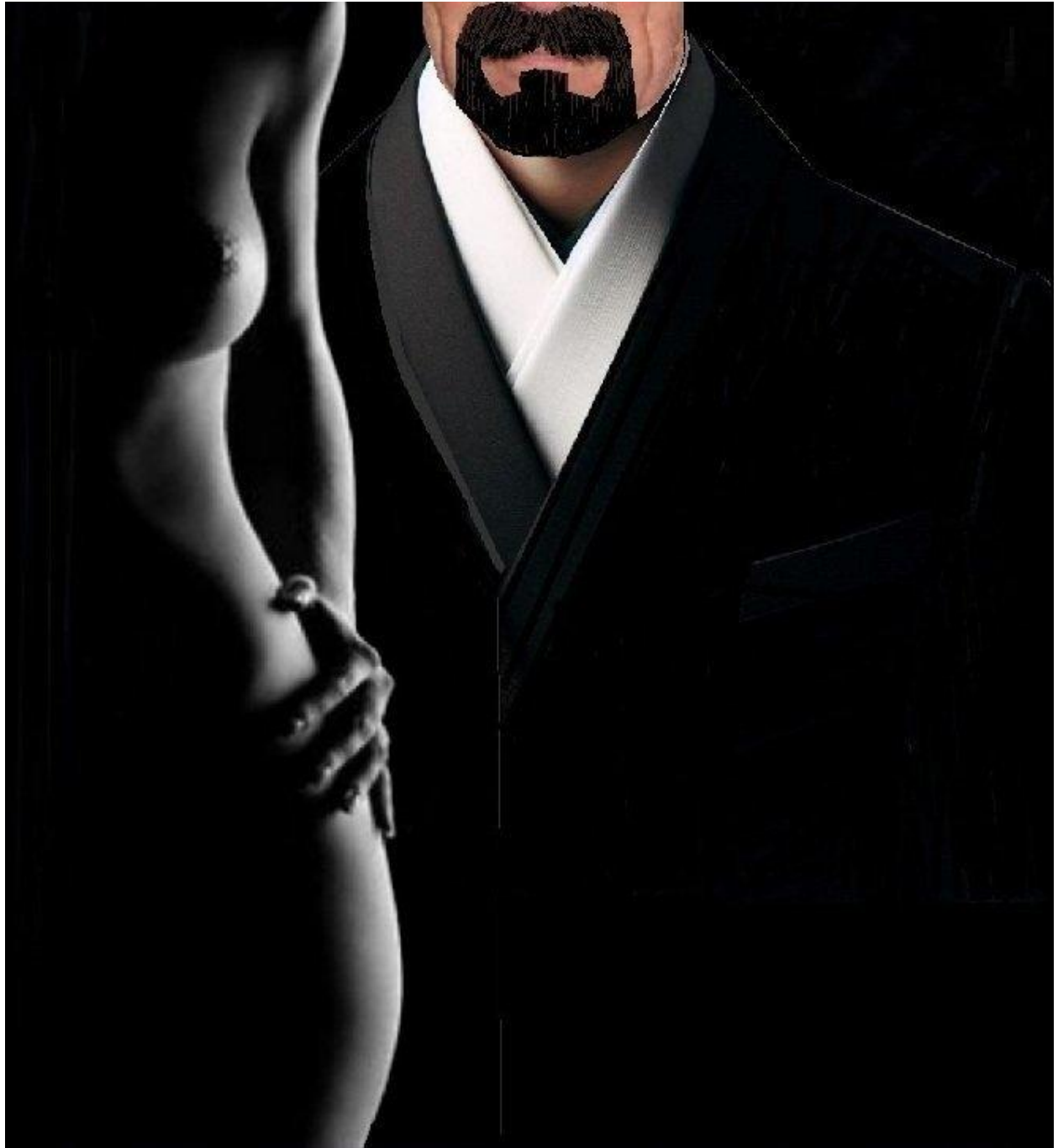



OFFWORLD MAN ANTHOLOGY

THE ULTIMATE COLLECTION

G.K. WALKER

The Off-World Man
CHAPTER 6
EXCERPT

"Well, Gordon, we think you're going to be pleased with the new lift motor for the GMC Schaubberger mini turbine. It takes a charge well—better than any we've tested so far, and it doesn't over-rev and short out from the high voltage like the last few motors. We've worked out the impeller induct fan r.p.m. rise problem. We made some adjustments to the onboard A.I. computers, regulating the synchronicity of it with the maneuvering pod engine systems. It's smoother, more gradual now. No choppy airframe excite due to uneven r.p.m. increase. Once she's up over 15,000 r.p.m., she potatoes and whistles softly, like she's alive, man. She idles, hovers solid like she's resting on wheels.

The motors are strong enough to run a sufficient charge through to the electrokinetic lifter sub-frame and Nitinol memory foil body panels, made of diamagnetic materials, coated with several hundred micro-layers of vacuum electron deposition produced magnesium and bismuth, under a ferromagnetic base coat, followed by micro-layers of zinc sulfide blended with silver, as specified, so the vehicle loses even more mass, and is subsequently easier to maneuver in OTS mode.

The liquid mercury-encased gyroscopic maneuvering pods are running at optimum subquantum kinetic efficiency, charged by the Motionless Electromagnetic Generator. Tests are ongoing with the Searle, Takahashi, Wankel, and Kawaj generators as replacements for the M.E.G. The steering yoke, paddle shift, and directional servo controls are tweaked. They operate like a high-end performance car, as you specified. The addition of that new digital resonance sound-dampening system worked well.

The vehicle can run completely silent in stealth mode, with just a hint of Coanda pulse, the military and law enforcement will love that. Or the driver can select any number of intimidating engine resonance registers. I've programmed in the distinctive whining growl of a vintage Ferrari 12-cylinder for this final test run. You'll feel like you're driving around in one from your private collection. The green touch bar on the steering yoke activates the sound resonance synchronization.

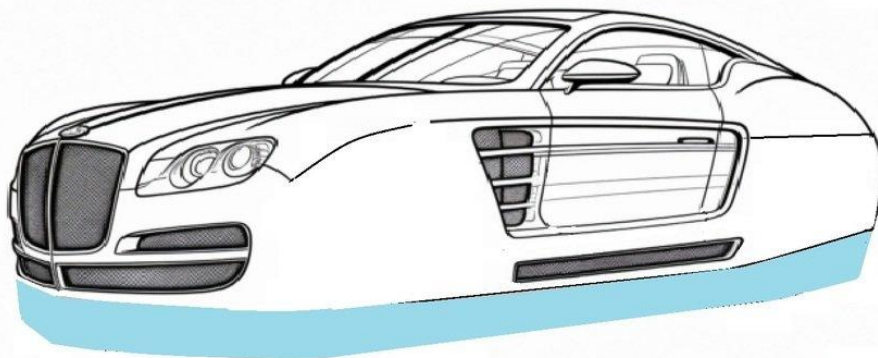

In layman's terms, she's a beast. Every military and law enforcement agency in the world will want a fleet version of this machine. We've just struck gold here, Gordon. Do you hear me? Now you've got to tell me, how did you know that sound resonance sync system would work?"

Dr. Parks gave his Chief Engineer a wink and a mischievous grin. "I didn't, Chet. I just remembered an article I read about airports and jet engine noise canceling research in the 1990s. It seemed appropriate for the prototype, so I put you guys on it. Over the years, as I've researched several modes for successful multiple hybrid gravitic propulsion, I must have filed away literally hundreds of aerospace and technical research advances that might someday be applied to the overall engineering design solution. And, so too, have thousands of other aerospace engineers and inventors before me. It just seemed to fit the puzzle. You know what I mean?"

"Well, good call, Gordon. I guess that's why you're CTO and CEO."

"Not anymore. I've given it some thought. I don't make this operation run; you do. Congratulations, Chief Technical Officer."

"I'm grateful, Gordon, you've got a deal. We'll go into salary and perks later, right now, we're chasing sunlight, so to speak. Our testing time is almost up. Saddle up, and I'll see you when you make it back around the loop. So far, I haven't seen any OHC brass, just the emergency fire team escorts. But take her easy anyway, okay?"

"I'm getting tired of this slow-speed chase crap, Chet. I'm tempted to open her up. No one's out here on the loop this early."

Chet registered a look of caution and shrugged his shoulders, afraid to comment.

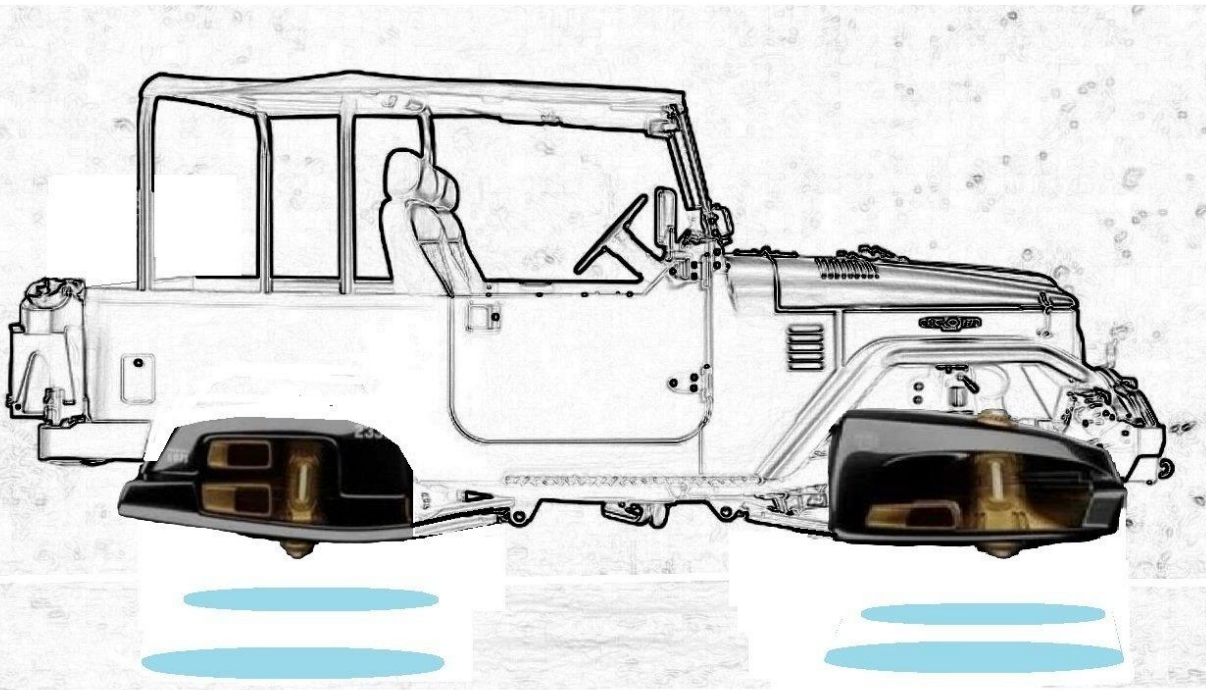

ICON HAND MADE

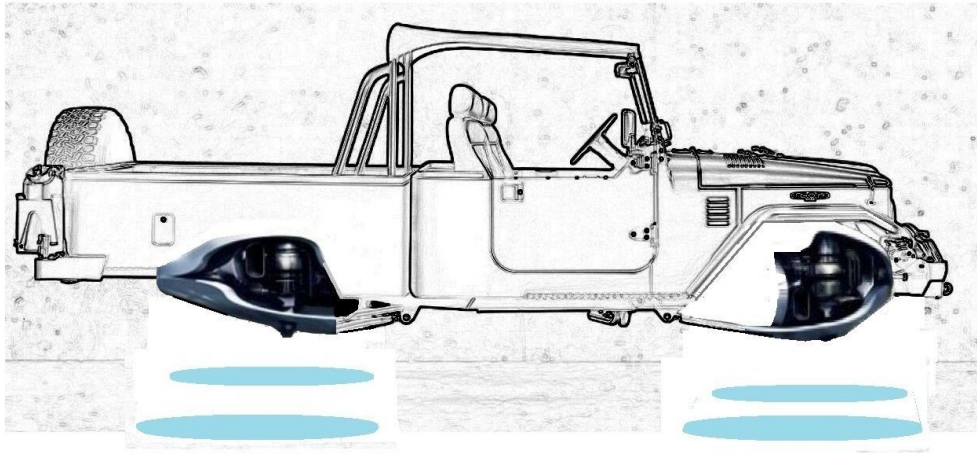

ICON HAND MADE

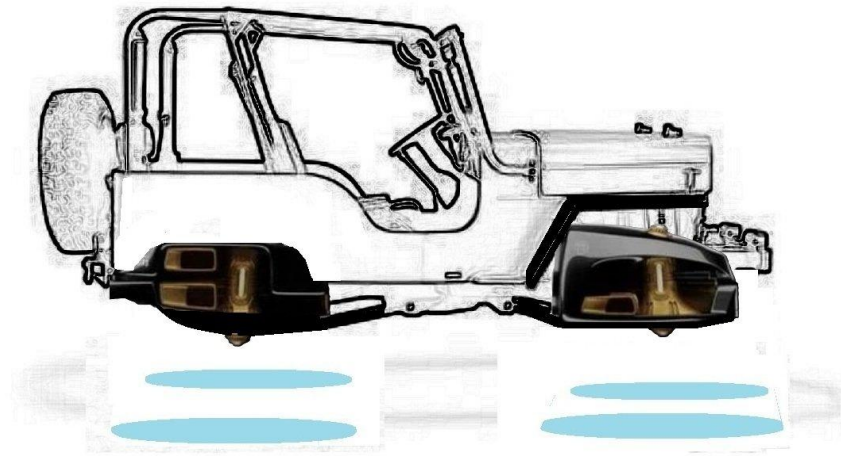

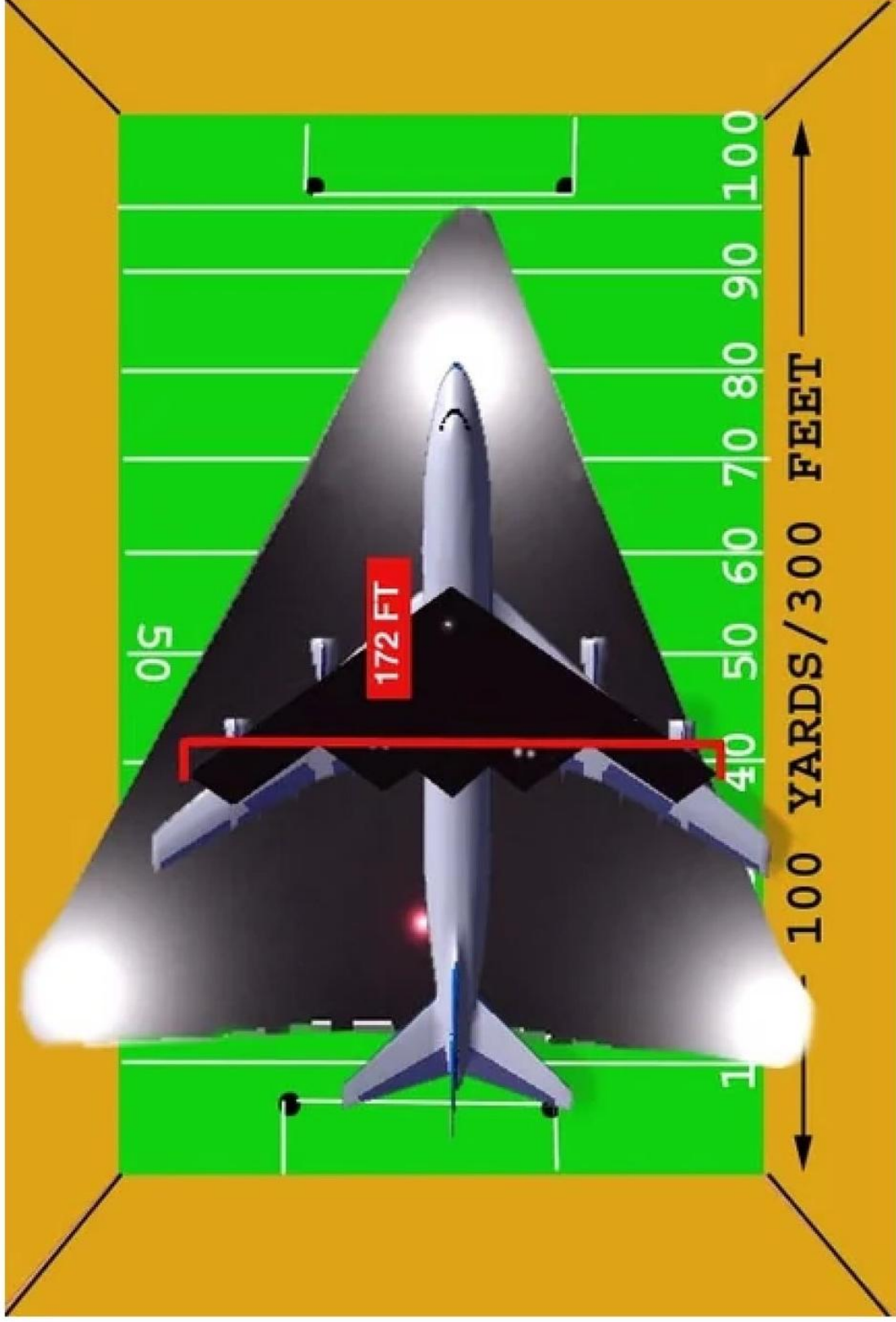

Utah desert spaceplane

600 ft x 100 ft
(180m x 30 m)

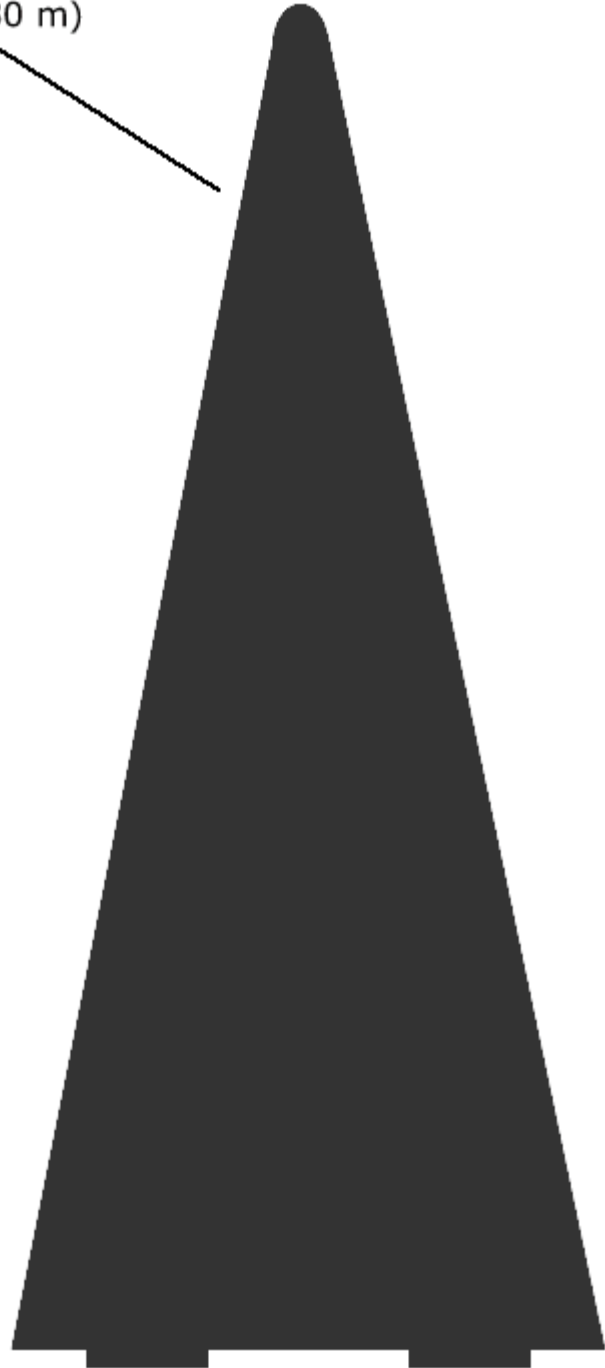

Hughes H-4 "Spruce Goose"
Length: 66.6 m
Span: 97.5 m
Height: 24.1 m

Boeing 747-400
Length: 70.6 m
Span: 66.4 m
Height: 19.4 m

Airbus A380-800
Length: 73.0 m
Span: 79.8 m
Height: 24.1 m

An-225 Mriya
Length: 84.0 m
Span: 88.4 m
Height: 18.1 m

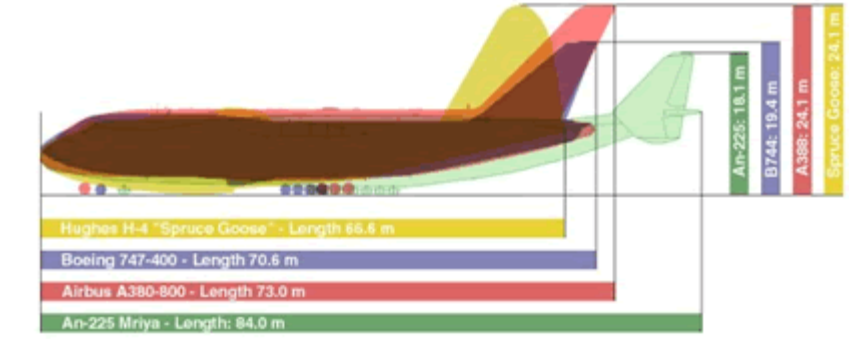
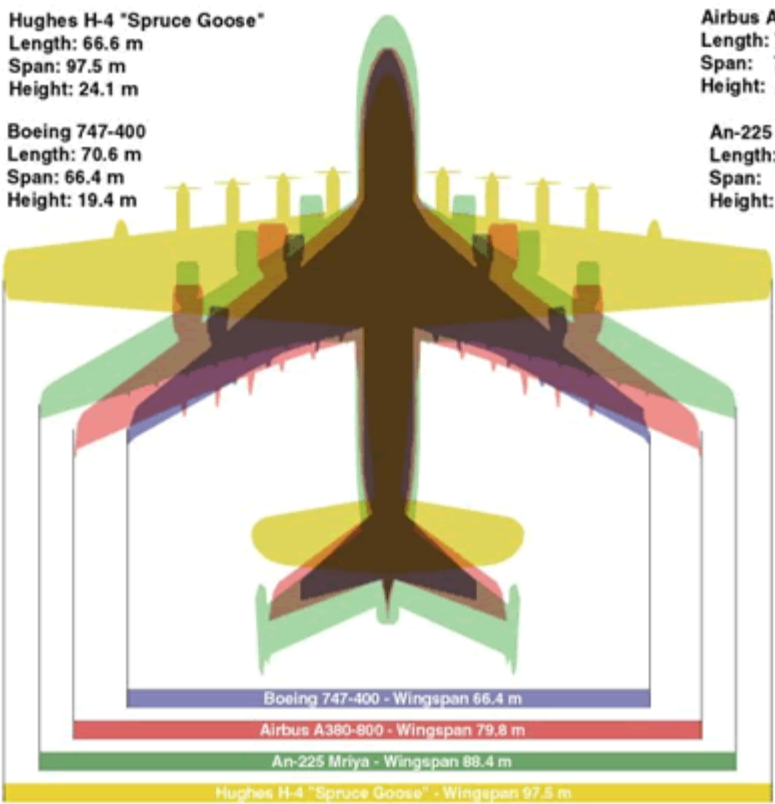



HOW DO YOU FUNCTION AFTER
DISCOVERING THAT EXTRATERRESTRIALS
THINK OF HUMANITY THE WAY WE THINK
OF LIVESTOCK?

An awakened Humanity, aware of its heritage and potential, would not be livestock. It would be sovereign. The destruction of knowledge is no accident of history.

The suppression of Gnostic texts, the rewriting of scriptures, the erasing of indigenous memory.

These are not isolated tragedies. They are deliberate strategies. A species kept ignorant cannot rise. A species kept divided cannot unite.

A species kept fearful will never awaken. And so, the cycle repeated.

Humanity stands at the edge of a new age.

Remembrance is rising within the human code, lies something they cannot predict, cannot edit, cannot erase, call it soul, call it consciousness, call it spirit. It is the spark that dreams of freedom. The spark that reaches for the stars. The spark that whispers in the quiet of the night.

I am more than I was told. This spark breaks through even in captivity. messages left for us by those who remembered. The hybrids walk among us. The laboratories hum beneath our feet.

But above, on the surface, something stirs.

People begin to question. Symbols begin to be seen for what they are. The cage trembles, and in that trembling lies the beginning of freedom.

We are equal. We're just not maybe as aware as they are. But that doesn't mean that any race is any better or any less. In fact, we're all equal.

REFERENCE and YOUTUBE UAP GERB



EXO

EXECUTIVE OFFICER

EXO

EXECUTIVE OFFICER

A true mystic follows nobody's path, rather creates one, knows no authority and bows to nobody.

Mysticism is not a religion, but a lone journey where one becomes awoken from within. Illumination is the win of light over darkness

The age of
believing is over.
We're in the age of
knowing.

ENGINEERS may lead the way--

But DESIGN ENGINEERS Build the Future...

A Design Engineer's calling (in life) is to create technological design solutions that improve the human condition. There is no greater, more noble calling, besides being in public service, such as serving in the military, or as a law enforcement officer, or an emergency service technician, or a medical professional.

The Orbital Manufacturing Group was founded to offer advanced consumer products with minimalist design aesthetics in order to free the attention of the trend-conscious. Our iconic products are designed to influence our consumers to focus their attention inward, toward their spiritual center, and cultivate lifelong learning and creative pursuits; this is the Renaissance lifestyle.

The practitioner of the Renaissance lifestyle is focused on the daily pursuit of knowledge, truth, and spiritual growth through the record of their creative hobbies. From painting and digital art expression, to traditional and 3D sculpture and digital printing, to writing in all its forms, to musical composure and film production, to research in all its forms, to study of astronomy, physics, and new physical and medical sciences. These creative pursuits make a lasting contribution to the human condition, the eternal continuum of souls. We promote positive thoughts and actions through prayer, meditation and non-local introspection for increased spiritual and creative focus of the inner eye and crown chakra.

This is the mission of OM Group, and it has always been my mission since I decided to train to become a mechanical engineer and an industrial designer. We are not naïve utopians; nothing could be further from the truth. We are, however, committed to solving the social ills, whether small or large, of our age, if we are able. We are solution-oriented; Renaissance people are problem solvers.

ORBITAL MANUFACTURING GROUP





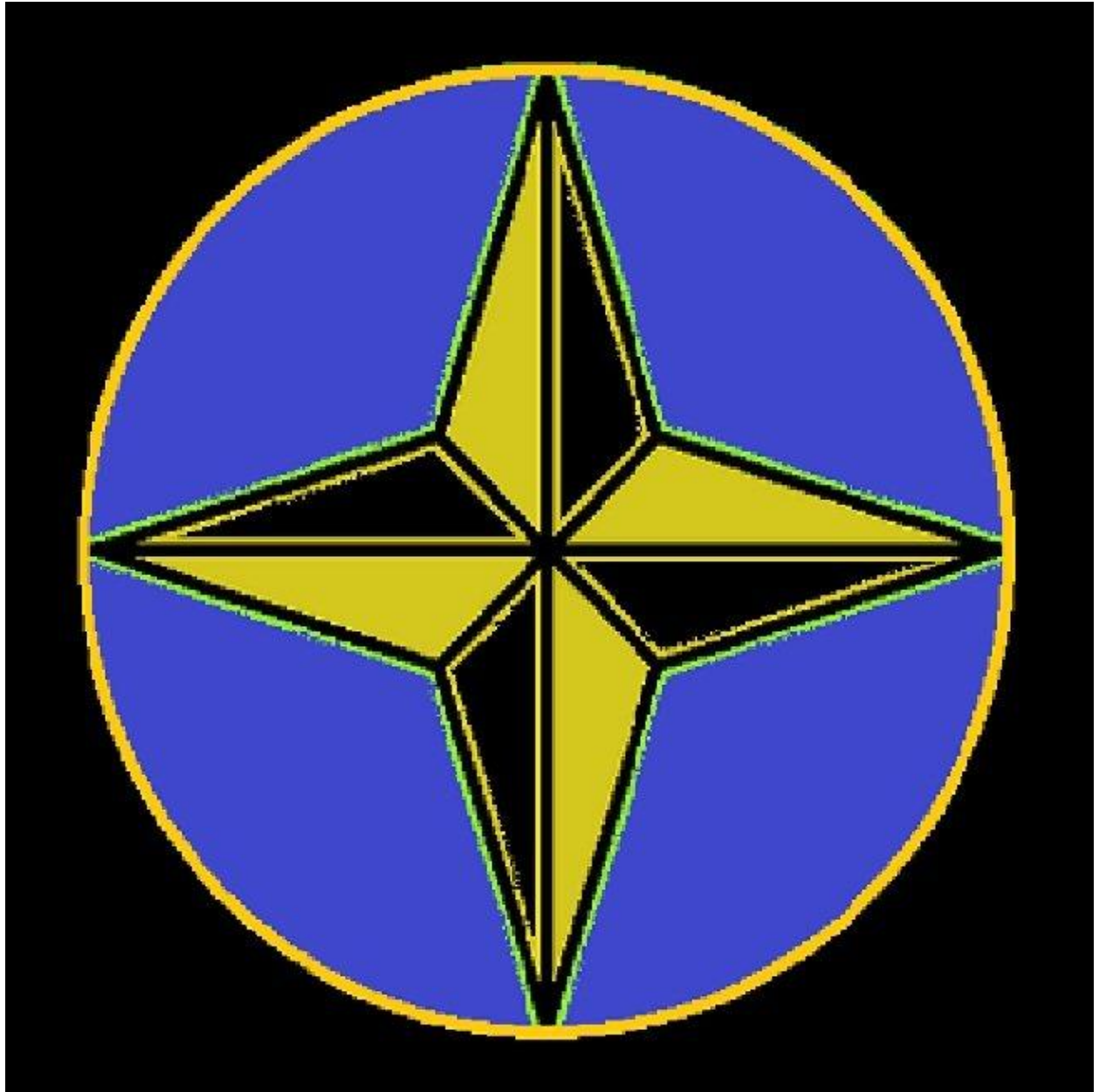



Z DIVISION



UNITED STATES
SPACE FORCE

