

The diamond–vacuum interface: II. Electron extraction from n-type diamond: evidence for superconduction at room temperature

Johan F Prins

Department of Physics, University of Pretoria, Pretoria 0002, Gauteng, South Africa

Received 20 February 2002

Published 7 February 2003

Online at stacks.iop.org/SST/18/S131

Abstract

It is shown experimentally that n-type diamond is a negative electron affinity material from which electrons can be extracted at room temperature. This is achieved by generating an ‘ohmic’ tunnelling contact to the vacuum. It is found that the extracted electrons within the gap between the diamond surface and the anode are able to form a stable, highly conducting phase. Band theory, combined with the equations that describe electron transport in a vacuum diode, unequivocally show that the distances between these electrons, as well as their speeds, must keep on decreasing as long as there is an electric field between the diamond surface and the anode. This implies that steady-state current flow, as experimentally observed, can only occur if this field becomes zero while still allowing a current to flow from the diamond to the anode. The only way to achieve such a situation is for the extracted electrons within the gap to form a superconducting phase. Because electrons are fermions, an unabated decrease in their nearest-neighbour distances as well as their speeds should eventually force them to violate the Heisenberg uncertainty relationship. At this limit, they become restricted, as pairs, within volumes or ‘orbitals’ which in turn fill the whole space between the diamond and the anode. Because these ‘orbitals’ have zero spin, they are boson-like charge carriers, and because they are as near to each other as is physically possible, they automatically constitute a Bose–Einstein condensate; i.e. they constitute a superconducting phase.

1. Introduction

The discovery that a hydrogen-terminated (111) surface of p-type diamond has negative electron affinity (NEA) [1] aroused the anticipation that n-type diamond may act as an ideal cold cathode. However, a theoretical analysis of the properties of an ideal, infinite interface between an n-type semiconductor with NEA and the vacuum [2] has led to the conclusion that electrons must be present in the vacuum just outside of the surface. There, they are bound in quantum states within a distance w_e from the surface; i.e. an ‘electron-charge’ layer is formed. An equal number of positive charges residing on ionized donors of density N_D form a depletion layer, of width w_n , at the surface of the semiconductor. In this way a dipole is generated, such that the magnitude of the charge

density, per unit area, is the same within the depletion- and electron-charge layers. Each is equivalent to a surface charge density σ_S , such that

$$\sigma_S = eN_D w_n = e n_C w_e. \quad (1)$$

n_C is the average electron density within w_e , and e the electronic charge unit. Each layer generates a field at, and just outside, the diamond surface given by [2]

$$E_{Mv} = \left(\frac{E_{MV}}{2} \right) = \frac{\sigma_S}{2\varepsilon_0} \quad (2)$$

where ε_0 is the permittivity of the vacuum. When adding the two E_{Mv} together, one obtains the total field E_{MV} in the vacuum at the surface. Just below the surface, within the diamond, the

equal fields generated separately by the depletion layer and the electron charge layer are given by

$$E_{\text{Md}} = \left(\frac{E_{\text{MD}}}{2} \right) = \frac{\sigma_{\text{S}}}{2\epsilon_{\text{n}}}. \quad (3)$$

ϵ_{n} is the permittivity of the diamond, for which one can write $\epsilon_{\text{n}} = \kappa_{\text{n}}\epsilon_0$, where κ_{n} is the dielectric constant. Although the same total field in the vacuum, E_{MV} , penetrates the diamond, it is reduced, by κ_{n} , in strength to become E_{MD} . The equivalent fields, E_{MV} and E_{MD} , at the interface are screened such that there is no electric field outside the dipole structure. This shielding of the electric field prevents further electrons from being extracted into the vacuum. Another way to view this equilibrium situation is to note that the screened field causes band bending within the depletion layer, which generates a barrier against further, net, electron flow out of the semiconductor. It has been deduced that at room temperature, the barrier height against further electron emission is equal to the magnitude of the NEA χ of the semiconductor. Furthermore, the analysis showed that if a field were applied to extract electrons into the vacuum, the widths, w_{n} and w_{e} , of the depletion- and electron-charge layers respectively, would increase to larger values w_{nf} and w_{ef} . Accordingly, the barrier height against electron egression also increases. This model explains why cold cathode experiments, using n-type doped diamond substrates [3–6], have had limited success to date.

In this study, pioneering experimental results are reported that illustrate how electrons can be extracted at room temperature from type IIa (high purity) diamonds after generating ‘ohmic’-tunnelling contacts by means of oxygen-ion implantation, and how these electrons are then able to establish a stable, highly conducting phase between the diamond and the anode. By applying the accepted standard equations that describe electron transport, it is shown unequivocally that the extracted electron density has to keep on increasing, while at the same time, the differences in the respective energies of these electrons must keep on decreasing until a Bose–Einstein-type condensate consisting entirely of electron pairs has to form.

2. ‘Ohmic’-tunnelling interface between an n-type NEA semiconductor and the vacuum

The depletion layer which forms within an NEA, n-type semiconductor at an ideal vacuum interface is similar to the one that forms when an ideal Schottky diode is generated between an n-type semiconductor and a metal [2]. The two types of interfaces differ in that one forms a junction to an insulating vacuum, while the other forms a junction to a conducting metal.

When a Schottky diode is biased in the reverse direction, very little increase in the electrical current is observed. When biased in the forward direction the diode conducts when electrons move into the metal after overcoming this barrier. However, by doping the surface layer of the semiconductor to a very high density, the diode characteristics can disappear because the depletion layer becomes so narrow that the electrons are able to tunnel through it. Current flow can then occur with ease in both directions; i.e. an ohmic contact has been established.

Although the concept of an ohmic contact between a semiconductor and an insulator does not make any sense, it is now postulated that a method to extract electrons from an n-type, NEA semiconductor, would be to generate an ‘ohmic’-tunnelling contact to the vacuum by over-doping the surface and near-surface region of the semiconductor with shallow donors.

3. Experiments and results

3.1. Low-energy oxygen implantation

Suitable oxygen-ion implantation can generate shallow donors at ≈ 0.32 eV below the conduction band, in diamond [7, 8]. These donor states are (believed to be) situated above the vacuum level, and are, therefore, metastable electronic flaws, which need to be quenched in by low-temperature annealing (below ≈ 600 °C). It has been proposed that they may be oxygen interstitials trapped at, and ‘chemically’ bonded to vacancies [9]. If such an oxygen-doped diamond is, indeed, an NEA, n-type material, it seems logical to try and generate an ‘ohmic’-tunnelling contact to the vacuum by low-energy oxygen-ion implantation.

In the previous doping experiments with oxygen [7, 8], keV-ion energies had been used. Ions of this energy leave the near-surface region reasonably intact owing to the inelastic electron interactions, which, at first, slow the ions down [10]. To over-dope as near as possible to, and even the surface itself, lower energies would be preferred. However, as already mentioned above, these oxygen-related donors are probably metastable flaws, and if they are created very near to the surface, their stability may be affected by the proximity of the surface. Therefore, it was decided to initially use insulating diamonds, dope them with very low-energy oxygen ions and then study the electrical properties of the resultant, near-surface layers on their own.

The diamonds used were of high purity (natural type IIa) with randomly oriented surfaces, each with an area of 3.6×3.6 mm². It was decided to start off with ion energies well below 1 keV. The ions were extracted through a hole, from a direct-current (dc) oxygen-plasma, into the diamond surface. For the initial experiments, the extraction potential was -150 V, and the current density measured from the diamond, to the ground potential, was ≈ 0.3 mA cm⁻². The radiation time was 5 min. The results that were measured on this first diamond are reported in detail below.

No damage could be detected by optical microscopy. XPS measurements showed a massive increase of oxygen near the surface. By just pressing gold-plated contacts onto the treated diamond surface, ohmic conduction with a sheet resistance of $\approx 2.4 \times 10^8$ Ω could be measured. It was then decided to monitor this resistance in vacuum during heating to ≈ 400 °C, as well as subsequent cooling to room temperature. The applied potential used was 10 V. Annealing occurred during this process. After cooling, the sheet resistance was only $\approx 5 \times 10^6$ Ω . It was decided to anneal for another 3 h at 400 °C, in a high purity argon atmosphere, without applying a potential. After this anneal, the sheet resistance was found to have increased to $\approx 1 \times 10^{11}$ Ω , and the diamond conducted like an oxygen-doped diamond, which had been doped by keV-ion implantation. This result indicates that the injected

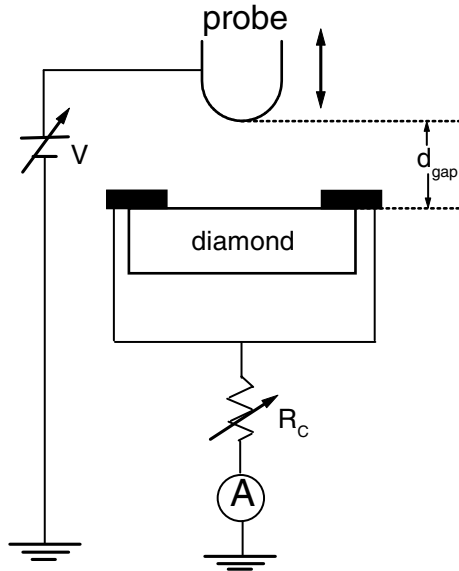

Figure 1. A schematic representation of the apparatus used to measure electron emission from n-type doped diamond. The probe was made of gold-plated stainless steel, and it could be accurately moved onto, and away from the surface of the diamond. The base pressure of the vacuum was better than 10^{-6} mbar, and the leakage current less than 1×10^{-11} A.

oxygen ions did not just form donor states very near to the surface, but also deeper-lying donors owing to oxygen-interstitial in-diffusion [11], and that during annealing, without an applied potential, the near surface states are less stable than these deeper-lying ones.

The diamond was again treated with low-energy oxygen ions and annealed by heating it in vacuum with an applied potential of 10 V. However, once it reached a temperature between 350 and 400 °C, it was maintained within this temperature range overnight before cooling down. The sheet resistance obtained afterwards was $\approx 1.75 \times 10^6 \Omega$. From the above results, the deduction was made that the implanted surface then, most probably, consisted of a deeper-lying, lighter-doped, n-type layer and an over-doped surface layer that may be able to form an ‘ohmic’-tunnelling contact to the vacuum, provided the diamond is an NEA material. It was thus decided to test this diamond for cold cathode behaviour.

3.2. Cold cathode measurements

The experimental arrangement is shown schematically in figure 1. The diamond was mounted as a cathode in a vacuum with a base pressure less than 10^{-6} mbar. The gold-plated anode probe had a hemispherical tip with a radius of 0.5 mm, and could be accurately moved onto and away from the diamond surface [12]. At any time the gap distance d_{gap} was known within an accuracy of $\pm 0.1 \mu\text{m}$.

The probe was positioned to just touch the surface of the diamond, and a positive potential of 1000 V was applied. After short-circuiting the resistor R_C (see figure 1), a current of just over 0.5 mA flowed. The probe was then moved to a position $1 \mu\text{m}$ away from the diamond surface. The current, at first, decreased to about 0.29 mA, then jumped around erratically, before it finally settled down at the same value it had when

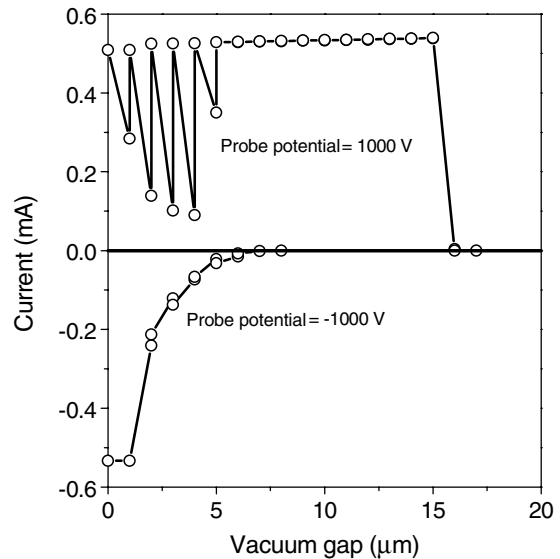

Figure 2. The current that was measured as a function of increasing probe distance d_{gap} (see figure 1) from the surface of the oxygen-doped diamond (with an ‘ohmic’-tunnelling contact). Initially the probe was at +1000 V. The measurements were then repeated using a potential of –1000 V.

the probe made contact to the surface. The probe was again pulled back to increase the gap to $2 \mu\text{m}$. Again, the current decreased and recovered again. This kept on occurring as the gap was increased. The results can be seen in figure 2.

After the measurements at $4 \mu\text{m}$ were completed, the system was allowed to stabilize for a far longer time than before. When moving to $5 \mu\text{m}$, the drop in current was less. After that, the time for stabilization, after each $1 \mu\text{m}$ increase in the gap size, was made even longer, and the probe could be moved slowly right out to $16 \mu\text{m}$ before the current dropped away. It was then found that by moving the probe back towards the surface, one could again pick up the current of ≈ 0.5 mA before reaching the surface, and again increase the gap slowly without losing the conduction. However, if one increased the gap too fast, the current could fall away very quickly. The slight increase in current with increasing gap, as seen in figure 2, is a result of the diamond heating up owing to the current flowing through it during the time it took to make the measurements.

After the measurements with the positive potential were completed, the probe was again moved onto the surface, and the voltage switched to negative, before pulling it away from the surface. The fascinating result ensued that the current did not drop away after moving the probe to leave a gap of $1 \mu\text{m}$ (see figure 2). However, further increases in the gap caused a decrease in the current, which now did not recover to the larger negative value at zero gap distance, until, at $7 \mu\text{m}$, it became zero.

The positive voltage was again applied. It was found that it is not necessary to start off with the probe touching the surface. By first setting the gap, and then increasing the positive potential, the current established itself over the gap when the potential reached a suitable value. For a gap width of $10 \mu\text{m}$ the required potential was ≈ 420 V. After the current had stabilized at the latter gap width, the potential was changed

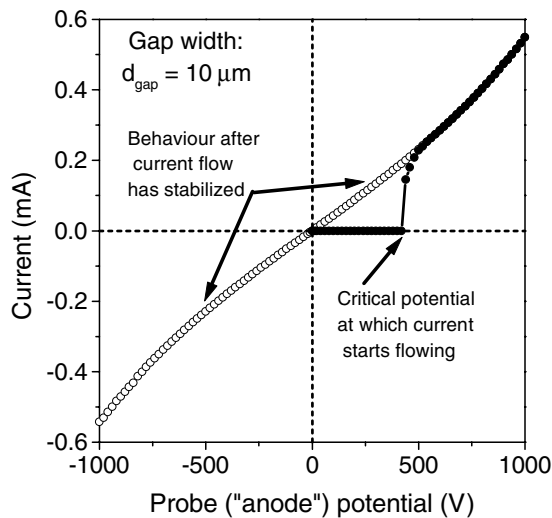

Figure 3. The current that flowed between the oxygen-doped diamond (with an 'ohmic'-tunnelling contact) and the probe (see figure 1) as a function of probe potential after starting with a preset gap width of $d_{\text{gap}} = 10 \mu\text{m}$. Initially no current flow occurred with increasing positive potential, until a critical potential of $\approx 420 \text{ V}$ had been exceeded. After the current had then been allowed to stabilize, its behaviour was the same whether the potential was positive or negative. Careful experimentation has led to the conclusion that the negative current can only be ascribed to the presence of electrons, which were extracted from the metal probe into the gap and then into the diamond (see the text).

from +1000 V in steps down to -1000 V , while monitoring the current. Current could now be measured for potentials lower than 420 V, as well as negative potentials. The results are shown in figure 3. For the same magnitude of the potential, the same current flow occurred in both directions when the polarity was changed from positive to negative. Furthermore, when pushing the probe against the surface, exactly the same curve was measured; i.e. the current was, within experimental error, the same whether there was a gap or not. This means that the voltage drop over the gap was negligibly small: within experimental error, zero. One should note that if the potential drop over the gap was actually zero, the gap had changed from initially being an insulator (the vacuum) to become a superconductor.

It was also found that one could now switch off the potential, even for a week and longer, without the conducting material, within the gap, disappearing. When subsequently switching on, at any potential between 1000 and -1000 V , the current started flowing at the appropriate corresponding value shown in figure 3 (taking the diamond temperature into account). Even when breaking the vacuum and removing the system from the vacuum chamber, this conduction persisted. One could then actually observe the gap between the diamond and anode probe. No extraneous material could be seen within this gap during conduction. Furthermore, subsequent, careful microscopic examination of the diamond and probe surfaces showed no evidence, whatsoever, of any contamination, for example, a filamentary material, which could account for the observed conduction.

Since this pioneering experiment had been done, the same experiment has been repeated on a host of other diamonds, and in each case where the surface had been over-doped with

shallow donors, commensurate results could be measured. At present, such diamond substrates are being generated with sheet resistances as low as $10 \text{ k}\Omega$, and it should be possible to decrease these resistances even further. For one diamond the gap between the diamond and the anode could be increased to $100 \mu\text{m}$ before the conduction fell away.

In order to ensure that these results were not caused by some other mechanism, for example, by contamination or another extraneous contact between the diamond and the probe, the experiment was repeated using a large number of alternative substrates. Not in one of these cases could the same, or even similar, results be obtained. For example, a p-type semiconducting (type IIb) diamond as well as a polished cemented tungsten carbide block with the same surface area as the diamond, was studied. The surface of the type IIb diamond was rendered ohmic by over-doping with boron as described elsewhere [13]. The resistance of this diamond was orders of magnitude lower than the oxygen-doped one used for the experiments described above. Therefore, after positioning the probe on its surface, the resistance R_C (see figure 1) was adjusted to ensure that the same current flowed as had been measured for the oxygen-doped diamond. When pulling the probe away, the current immediately fell to zero and stayed there. At a gap distance of $10 \mu\text{m}$, with the resistor R_C set to zero, the potential was increased from zero. At about 600 V, some conduction started, but it was erratic and fell away very fast. After the removal of the diamond from the vacuum equipment, it was noted that its surface below the probe was damaged and pitted. This is in stark contrast to the oxygen-doped diamonds, which showed no damage whatsoever. When the same experiment was repeated on the tungsten carbide block, the current again dropped to zero, and stayed there, as soon as the probe point cleared the surface.

4. Discussion

One must consider the possibility that the current flow between the diamond and the anode may have been caused by an intermediary, conducting material, i.e. maybe some filamentary contact, for example, nanotubes. However, the growth of such filamentary fibres in an oil-free system at a vacuum better than 10^{-6} mbar is highly unlikely, and even if they could grow, the same stable conduction current, observed for different gap distances, would have been highly improbable. Furthermore, as already mentioned above, careful examination of the surfaces showed no trace of any filamentary material that could have been responsible for such an extraneous contact. In addition, by comparison with a host of other possible cathode materials, the reported results could only be generated for n-type doped diamond. By elimination, the only mechanism by which current flow could have occurred between the diamond cathode and anode probe must have been by means of electron transport. If this conclusion is correct and there exists no experimental doubt that it has to be correct, it forces one to further conclude that the highly conducting, stable phase, which had been generated within the gap, must have consisted entirely of electrons. However, these conclusions raise serious questions that need to be answered:

1. Why, and how, do electrons accumulate within the gap to form this highly conducting phase?

2. Is this gap phase superconducting, as indicated by the experimental results, and why should it be?
3. Why does this gap phase, once established, allow current to flow in either direction (see figure 3)? This implies that electrons are easily extracted from the metal probe when a negative potential is applied to it.
4. Why does this gap phase remain stable when the potential is switched off? Electrons are charged, and should repel each other. One would have expected that they should ‘explode’ out of the gap.

The only imaginable situation under which individual electrons, on their own, can coexist in a vacuum without rushing away from each other, is when they fill an infinite universe with a uniform density. An equivalent situation would arise if the electrons could be confined within a hypothetical container with walls from which they are perfectly reflected. Also in the latter case, one may then argue that each electron is equally surrounded by an infinite number of other electrons. Accordingly, all the electrical forces exerted by the surrounding electrons on a randomly chosen, specific electron, must, according to Gauss’s law, cancel within any sphere that surrounds only this electron. When one of them moves substantially (over a distance larger than its nearest-neighbour distance), the others will also have to move in order to keep the forces in balance at the instantaneous position, each and every electron finds itself at.

Because there are no atoms present that can produce phonons to scatter electrons, it seems attractive to reason that such a collection of individual electrons in a vacuum must be superconducting. However, the absence of atoms is not a sufficient condition for superconduction to occur. In this respect, it is informative to consider electron flow in a thermionic vacuum diode. A space charge region consisting entirely of electrons is thermally generated and maintained just outside the cathode surface. When applying a potential to the anode, electrons are easily extracted from the space charge to move to the anode. An electron at the vacuum level, just outside the cathode, will be accelerated such that at position z , as measured from the cathode, it will have gained kinetic energy, $E_{\text{kin}}(z)$, given by [14]

$$E_{\text{kin}}(z) = \frac{1}{2}mv(z)^2 = \frac{p(z)^2}{2m} = e\Phi(z). \quad (4)$$

$\Phi(z)$ is the electrical potential relative to the cathode, m is the electron mass, $v(z)$ is the speed of the electron and $p(z)$ is its momentum. If the density of electrons which are free to take part in conduction is $n(z)$, the current density $J(z)$ may be derived from equation (4) as [14]

$$J(z) = en(z)v(z) = en(z) \left[\frac{2e\Phi(z)}{m} \right]^{1/2}. \quad (5)$$

The latter relationship is used in the derivation of the well-known Child–Langmuir equation. Although the current flow, described by equation (5), is occurring within a region in which there are no atoms present, a potential $\Phi(z)$ is required to drive the current. The electrical resistance is, thus, not zero.

Assume that the present experimental arrangement can be interpreted in terms of infinite, parallel diamond and anode surfaces. Consider the case where the gap between these surfaces is preset at a distance d_{gap} , which is further from the

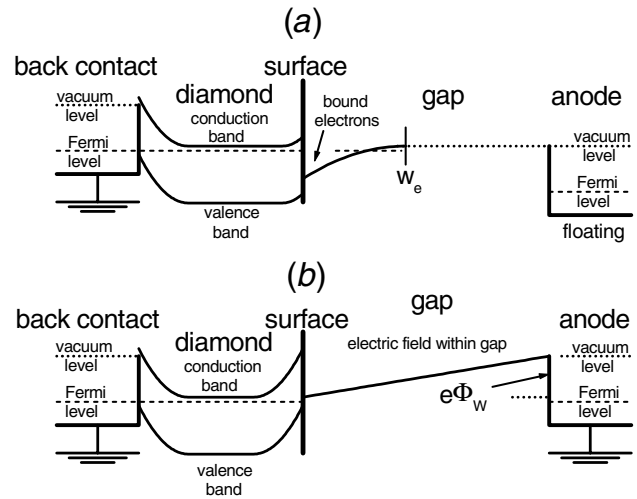

Figure 4. Energy band diagrams showing the electron-charge layer at the surface of the diamond: (a) the diamond, its surface, and the electron-charge layer, just outside the surface, after generating an ohmic, back contact, but before making electrical contact to the anode; (b) the same energy diagram after connecting the anode to ground potential. A field, with its concomitant potential Φ_W , is generated within the gap.

diamond surface than the width w_e of the electron-charge layer. The expected energy band situation after generating an ohmic metal contact to the diamond and before electrical contact has been made to the anode is shown in figure 4(a). The width of the corresponding depletion layers at the surface as well as the back contact has been exaggerated to show the band bending. In the present experiments, the surface regions were highly over-doped, and these depletion layers should, thus, be extremely narrow.

Figure 4(b) shows the expected result when the anode, with work function W , is grounded. This action connects it to the back contact and, thus, also to the diamond. Because the Fermi level of the back contact and the diamond is higher than the Fermi level of the anode, a field will be generated from the diamond surface, through the diamond, the back contact and the connecting wires, which will attract electrons to flow into the anode, in order to raise the Fermi level of the latter. Once the Fermi levels have reached equilibrium, the field that extended from the diamond surface through the connecting wires will be neutralized. The electrons, of surface density σ_W , that flowed into the anode will now generate a field in the gap, at the anode surface, of magnitude $E_{(W/2)} = \sigma_W/2\epsilon_0$ (see equation (2)). Furthermore, because these electrons came from the interface between the diamond and the vacuum, there must be an equal and opposite positive charge at the surface. In the present case it is assumed that the magnitude of the electron affinity χ is smaller than the workfunction W of the anode. Accordingly, all the electrons within the original electron charge layer will have moved back into the diamond, and a positive depletion layer will have been established at the surface to generate a field, $E_{(W/2)} = \sigma_W/2\epsilon_0$, which screens the field of the anode outside the gap. Thus, the field within the gap is $E_W = \sigma_W/\epsilon_0$. This is equivalent to a negative potential, Φ_W , relative to the ground potential. If one assumes that the back contact and anode have the same workfunctions as had been the case in the experiment reported above, Φ_W

must be equal to the contact potential at the interface of the back contact to the diamond. Thus, for the same density of donors at the surface and back contact, the two depletion layers will have to be identical. The resultant situation is illustrated in figure 4(b).

When applying a positive potential Φ to the anode, the power supply will extract the negative charge from the anode and move it back to the back contact, from where these electrons can move to the surface of the diamond. Initially, for $\Phi < \Phi_W$, the field within the gap (as shown in figure 4(b)) must thus decrease. As soon as $\Phi = \Phi_W$ there will be no charge on the anode surface anymore. The electron charge layer and its concomitant depletion layer will then again be as they were in figure 4(a).

A further increase in Φ will now generate an opposite field between the back contact and the anode. Because the diamond is conducting, one can at first assume that the field mainly appears over the depletion layer, electron-charge layer and the vacuum between the latter layer and the anode [2]. As already described and discussed elsewhere [2], the dipole layer will also screen this additionally applied field by aligning the Fermi levels at its edges. This is achieved by generating more electrons within the depletion layer, which then add to the electron-charge layer. During this process, the widths of both these layers increase. When the field generated by the potential $\Phi_{VAC} = \Phi - \Phi_W$ appears, the electron-charge layer will, thus, expand into the gap towards the anode. The increase in its width w_e depends on the magnitude of the potential Φ_{VAC} [2]. If it is below a critical value, the increase in width will be less than the gap width d_{gap} . One can then increase the applied potential further, until, at a critical potential $\Phi_C = \Phi_{VAC} + \Phi_W$, the electron-charge layer will fill the whole gap; i.e. $w_e = d_{gap}$. If this happens, this situation would be as shown in figure 5(a).

A catastrophic equilibrium point would then have been reached, and this will be disturbed when the potential Φ is increased to be just larger than Φ_C . The self-consistent potential well must then expand into the anode. The anode is a conductor, and the self-consistent potential well cannot exist within it. Thus, the electrons which enter the anode become free to move. An electrical contact is established between the anode and the electron-charge layer, which must result in a field being generated to attract electrons into the anode in order to equalize the Fermi level outside its surface to the one within the anode. This field will add to the field which the dipole expansion is trying to neutralize. A direct field should, thus, be established owing to the offset between the Fermi levels at the surface of the diamond and the Fermi level in the anode. As an aside, it should be noted that for a large enough gap distance d_{gap} , the applied potential might become so high that the electron-charge layer breaks down before it can fill the whole gap [2]. However, once this happens, the electrons will still fill the whole gap and, thus, experience the field caused by the offset between the two Fermi levels. Whichever of the two mechanisms occur, the subsequent behaviour of the electrons is the same as that for a classical diode, described by equations (4) and (5). Electrons which exit the diamond are accelerated to the anode, and a current starts to flow. This conclusion is supported by the data shown in figure 3.

The resistivity ρ of the diamond now becomes important. Accordingly, the applied potential Φ will appear over both the

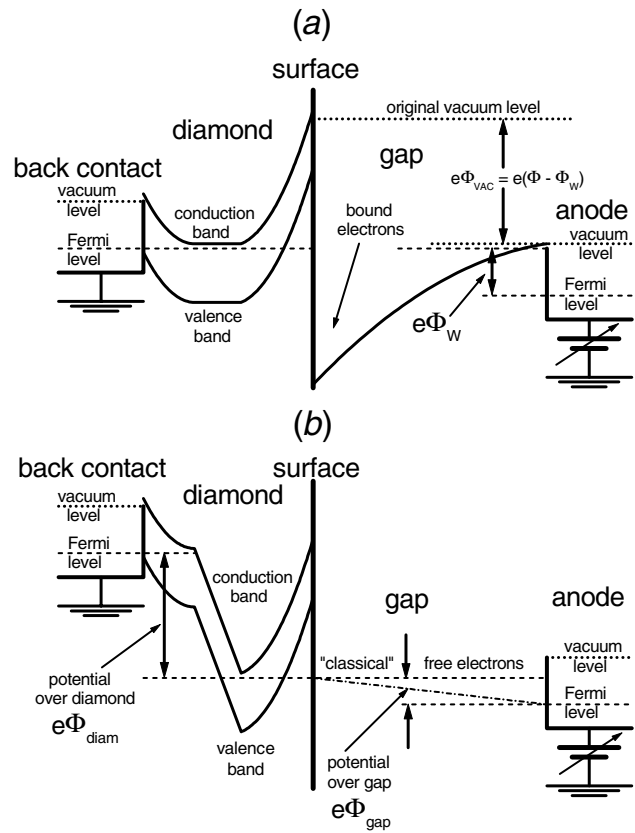

Figure 5. Energy band diagrams illustrating the critical potential Φ_C , above which electrical conduction through the diamond and gap initiates: (a) the situation, at a critical applied potential when the electron-charge layer has expanded to fill the whole gap between the diamond and the anode; (b) the situation when the field, within the gap, is large enough to cause the electron-charge layer to expand into the anode. The field, owing to the offset between the Fermi levels at the diamond and anode surfaces, accelerates the electrons, which exit the diamond, towards the anode.

diamond and the gap. It will be divided into a part Φ_{diam} , which produces the field E_{diam} that drives the current through the diamond, and Φ_{gap} , which relates to the field E_{gap} caused by the offset of the Fermi levels at the diamond surface and the anode. The expected energy band situation, after current flow has initiated, is shown in figure 5(b). One can now write for the current density J_{diam} through the diamond,

$$J_{diam} = \frac{E_{diam}}{\rho} = \frac{\Phi_{diam}}{\rho d_{diam}} \quad (6)$$

Within the gap, the current flow depends on the average electron density n_{gap} , and the current density J_{anode} , which flows into the anode, can then be calculated from equation (5); i.e.

$$J_{anode} = en_{gap} \left[\frac{2e\Phi_{gap}}{m} \right]^{1/2} \quad (7)$$

If the area through which the current flows through the diamond is A_{diam} , and the concomitant area at the anode interface is A_{anode} , the total current I can be written as

$$I = A_{diam} J_{diam} = A_{anode} J_{anode} \quad (8)$$

As long as $\Phi_{gap} > 0$, there will be a field E_{gap} between the anode and the diamond. And as long as there is a field at the surface of

the diamond, the depletion layer under its surface will attempt to eliminate this field by injecting electrons into the gap; i.e. the depletion layer will increase in width, and the average electron density n_{gap} will increase in magnitude. According to equation (7), an increase in n_{gap} must either increase J_{anode} or decrease Φ_{gap} . However, according to equation (8), in order to increase J_{anode} , J_{diam} must also increase, and this can only occur if Φ_{diam} (see equation (6)) increases. For Φ_{diam} to increase, Φ_{gap} must decrease. Thus, although an increase in n_{gap} causes an increase in the total current I , this is achieved by decreasing Φ_{gap} . Because the presence of Φ_{gap} (and thus E_{gap}) causes n_{gap} to increase, which in turn causes Φ_{gap} to decrease, steady-state equilibrium can only be reached when Φ_{gap} becomes equal to zero. A material that transmits a current while, at the same time, expelling an applied electric field from it must have zero resistance; i.e. it has to be a superconductor. Thus, in order to reach a steady-state situation, which is required by basic thermodynamic principles, the electrons have to find a way to form a superconducting medium.

It should now be noted that a decrease in E_{gap} with increasing n_{gap} causes the increase in the speeds of the electrons, owing to acceleration within the gap, to approach zero (see equation (4)). Furthermore, the electrons which tunnel into the gap through the extremely thin depletion layer do so from the lowest energy states of the conduction band. These states lie at an energy minimum in \mathbf{k} -vector (momentum) space. Thus, the initial speed of these electrons, which is determined by the gradient of the energy surfaces in \mathbf{k} -space [15], may be taken as zero. This implies that the decrease in acceleration within the gap, caused by the decrease in the field, has to force the actual speeds of all the electrons to approach zero; i.e. as the inter-electron distances decrease, the speeds with which the electrons move at any position $z > 0$ from the cathode surface approach the zero speed at the cathode. The conditions needed to form a Bose–Einstein condensate can be stated as follows [16]: ‘when a given number of particles approach each other sufficiently closely, and move sufficiently slowly, they will together convert to the lowest energy state possible’.

This is exactly what is now occurring for the electrons. Furthermore, the required conditions are approached without the need for cooling the electrons to temperatures near absolute zero.

It is well known that in order to generate superconduction, the charge carriers must form the same type of coherent state that underpins a Bose–Einstein condensate. It is therefore gratifying that the electrons which are being extracted into the gap are approaching the conditions where they are able to, exactly, form such a state. However, it is also known that such a state can only be formed by bosons, i.e. by particles with integral spin. Electrons are fermions with half-integral spin. It is for this reason that electrons have to form pairs with zero spin in order to act as charge carriers during low temperature superconduction. However, pairing of electrons, mediated by phonon interactions (Cooper pairs), as postulated for the BCS model [17], cannot be involved in the present case, because there are no vibrating atoms within the gap between the diamond cathode and the anode. Another mechanism needs to be found.

Owing to Gauss’s law, the electrostatic interaction of symmetrically distributed electrons surrounding a single

electron must cancel within the largest possible sphere that surrounds only the latter electron. It thus seems attractive to argue that there should be a negligible amount of mutual electrostatic repulsion between nearest-neighbour electrons. In addition, during the accumulation of electrons, the average distance between neighbours decreases. One may thus be inclined to reason that, eventually, the nearest-neighbour distance becomes small enough, such that the magnetic attraction between electron pairs with opposite spin becomes intense enough to bind such pairs together. However, it is well known that spin–spin alignment represents a far stronger apparent force than the magnetic interaction [18]. Thus, if bosons do form by direct pairing of electrons, as they are forced to do in the present situation, this process could represent a more fundamental interaction than mere magnetic attraction.

In this respect one should note that according to equation (4), the mean square deviation of the momentum of an electron in a region with an average uncertainty $\langle \Delta z \rangle$ in its position z , relative to the diamond surface, follows as

$$\langle \Delta p_z^2 \rangle = 2me \langle \Delta \Phi(z) \rangle = 2me E_{\text{gap}} \langle \Delta z \rangle. \quad (9)$$

The average volume occupied per electron in the gap is n_{gap}^{-1} , and the average distance between electrons in the z direction is thus

$$\Delta z = n_{\text{gap}}^{-1/3}. \quad (10)$$

However, two electrons with spin up and spin down can occupy the same volume. Thus, the mean square uncertainty in the position of an electron at z , in the z -direction, may be written as

$$\langle \Delta z^2 \rangle = \langle \Delta z \rangle^2 = 2^{2/3} n_{\text{gap}}^{-2/3}. \quad (11)$$

Although under the conditions being considered, the classical description of the electrons, by equation (7), prevails, the electrons are still subject to the Heisenberg uncertainty principle. One must, thus, have from equations (9)–(11) that [19]

$$\langle \Delta p_z^2 \rangle \langle \Delta z^2 \rangle = 4me E_{\text{gap}} n_{\text{gap}}^{-1} \geq \frac{h^2}{16\pi^2} \quad (12)$$

where h is Planck’s constant. As already concluded above, n_{gap} must continue to increase as long as there is a field within the gap. If this process continues unabated, a point must be reached at which n_{gap} becomes so large, for the prevailing value of E_{gap} , that equation (12) must fail; i.e. the Heisenberg uncertainty principle will have to become invalid. When $E_{\text{gap}}/n_{\text{gap}}$ does reach the Heisenberg limit, each electron pair is forced to stay within the coordinate constraints imposed by equation (12); i.e. each pair occupies a new type of spatially restricted ‘orbital’, and such ‘orbitals’ fill the space between the diamond surface and the anode completely. If one of the electrons attempts to act as an independent charge carrier, it implies that it has to exit the volume it shares with its partner and enter an adjoining volume. However, the latter volume will now already be occupied by an electron pair, thus preventing a third electron from entering it owing to the Pauli exclusion principle. Thus, any current within the gap has to, henceforth, involve the combined motion of electron pairs; i.e. each ‘orbital’ containing a pair of electrons has to move as a single

charge carrier with a charge of $2e$, and these charge carriers have integral (zero) spin, or in other words, they are boson-like entities. Thus, the charge carriers needed for superconduction automatically form at the Heisenberg limit. Furthermore, because these boson entities are touching each other, they are as close to each other as they ever can be. In other words, they will also, immediately, be in the configuration that constitutes a Bose–Einstein condensate. Thus, a superconducting phase forms automatically when the Heisenberg limit is reached.

It is not possible to define a Fermi level for bosons. However, the Fermi levels at the surfaces of the diamond and the anode are at the same energy. After all, it is to achieve exactly this situation that the electron density within the gap kept on increasing before the superconducting phase formed. The energy levels and band bending, after the formation of the superconducting phase, are depicted in figure 6(a). According to equations (6) and (3), the field within the diamond, E_{diam} , must now be given by

$$E_{\text{diam}} = \frac{\Phi}{d_{\text{diam}}} = \frac{\sigma_{\text{diam}}}{\epsilon_n}. \quad (13)$$

In other words, the power supply maintains an effective negative charge σ_{diam} at the back contact and an equal, effective, positive charge at the diamond surface, which is just large enough to sustain this field under the action of the applied potential Φ . This can only be the case if the positive depletion layer, just under the surface, and the superconducting negative electrons, in conjunction with those additional electrons that reside on the anode surface (after they have flowed into the anode in order to equalize the Fermi levels) form a dipole that screens their, jointly generated, electric field outside it. Thus, these charges cannot generate a field within the diamond. However, an effective charge σ_{diam} maintained by the power supply on the anode, will then appear as a field $E_{\text{diam}}/2 = \sigma_{\text{diam}}/2\epsilon_n$ in the diamond. In other words, all the electrons that were generated within the depletion layer, together with the depletion layer itself, form a dipole ‘contact’ to the diamond. This contact acts like the back contact. The anode has the same amount of negative charge on its surface, which is interfaced or ‘short-circuited’ by the superconducting phase and its corresponding amount of positive charge within the depletion layer, under the diamond surface. It should be noted that the depletion layer at the surface is wider than that at the back contact, because it also supplies the superconducting electrons.

Because the full potential is over the diamond, there is an offset between its Fermi levels at the back contact and the surface, which is equal to $e\Phi$. If one now switches off the power supply, the effective negative and positive charges on the back contact and anode, σ_{diam} , will disappear. The Fermi levels within the diamond will not be offset anymore. However, because the gap is superconducting, any offset, or non-offset, of the Fermi levels within the diamond does not affect the alignment of the Fermi level of the anode to the Fermi level at the diamond surface. Thus, the superconducting phase should not be affected by the applied potential, and with no potential applied, all the Fermi levels should still be at the same energy, as shown in figure 6(b).

Because the superconducting layer short-circuits the anode to the diamond, such that the interface between the anode and the diamond acts identically to the back contact, it

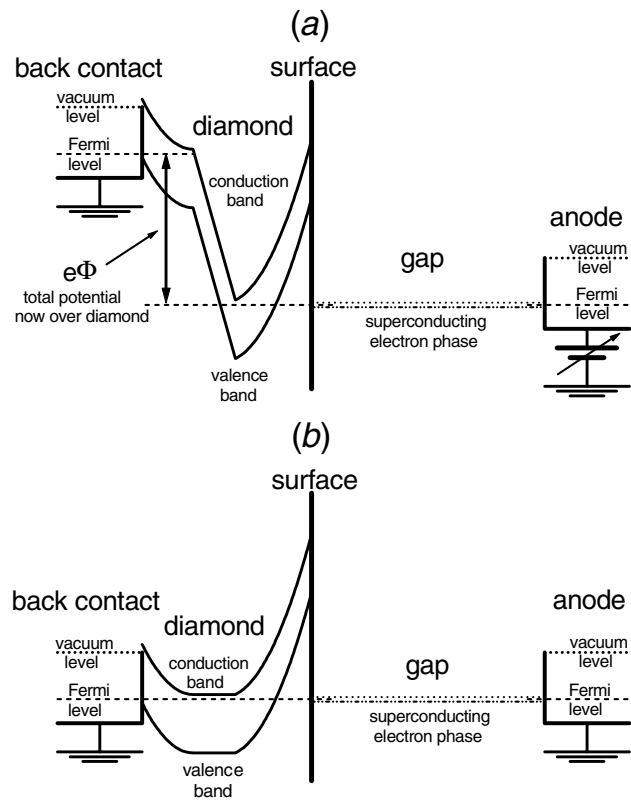

Figure 6. Energy band diagrams modelling the formation of a superconducting, electron phase within the gap of an NEA, n-type diamond and an anode: (a) the energy bands and Fermi level positions after the applied potential, over the gap, becomes zero; (b) the energy bands and Fermi level positions after the power supply has been switched off.

must also be ohmic, provided that electrons can tunnel through the wider depletion layer at the diamond surface. Thus, if any potential is applied to the anode, whether small, positive or negative, it will appear only over the diamond, and current flow determined by the applied potential and the resistance of the diamond will ensue. This explains why the current can flow in both directions, as shown in figure 3.

Although the electrons have formed a Bose–Einstein condensate, such that they should not be aware of any potential changes over the diamond, it is informative to still consider the possibility that the resultant charged particles could move out of the gap when the potential is switched off. Owing to the assumption that the interfaces are infinite, they cannot do so in any direction parallel to the diamond surface. If they want to leave, it will have to occur through either the surface of the anode or the diamond. However, both the diamond and the anode are not superconducting materials. Thus, the electrons cannot enter them as bosons, but will first have to break up into individual electrons. Added to this, the Fermi levels are aligned at these surfaces. Thus, if an electron succeeds to move out of the gap into either the diamond or the anode, the energy of the Fermi level at that surface will increase. Another electron must then flow into the gap to again equalize the Fermi levels.

However, in the actual experiment reported above, the diamond and anode surfaces were not infinite. A spherical tip and a small flat diamond were used. Thus, the shortest

distance from the diamond to the probe lies directly under the tip of the anode. When one moves sideways from this centre position, the distance becomes longer. At some distance from the centre position, the density of electrons should, just, not be enough to maintain the superconducting phase anymore. At that position, the electrons, although still filling the whole effective gap, should become bound within a self-consistent potential well, such as the one illustrated in figure 5(a); except that an extra applied field is now not needed to maintain it. Thus, if some of the latter bound electrons attempt to move out of the gap, the self-consistent potential should pull them back. Neither should electrons or electron pairs, nearer to the centre of the tip, be able to move into such a potential well without being pushed back. The superconducting condensate is thus ‘bottled’ in to stay under the tip of the anode probe.

It is now possible to explain the results shown in figure 2. If, after the superconducting phase had been established, the gap width d_{gap} is increased, the density of the electrons within the gap will decrease. What will then ensue depends on the magnitude of the applied potential Φ . If, for the increased gap width, it is not above the (increased) potential Φ_C , now needed to fill the larger gap with the required density of electrons (see figure 5(a)), the potential will be too low to re-establish the superconducting phase. The electrons within the gap become bound within quantum states. If the potential is higher than the required value for Φ_C , the superconducting phase can be re-established. However, immediately after increasing the gap width, a field will appear within the gap, which will attract more electrons out of the depletion layer under the surface of the diamond. To generate this field, some of the potential over the diamond must appear over the gap. The current through the diamond will then decrease (as observed). The field within the gap will attract electrons out of the depletion layer under the surface of the diamond. The latter’s width will increase, until, as discussed above, all the potential again appears only over the diamond. The change from a normal conducting to a superconducting phase is a discontinuous phase transition, and it is thus not surprising if the relative potentials over the diamond and the gap at first jump around erratically.

By continuously increasing the gap width d_{gap} , the depletion layer width as well as the required critical potential Φ_C also increase. At some stage, the gap width could exceed the size at which the applied potential Φ is able to reconstitute the superconducting phase. This, and the conductivity associated with it, will then fall away. One expects that this is what may have occurred when $d_{\text{gap}} = 16 \mu\text{m}$ for the experimental data shown in figure 2. However, it is also possible that the depletion layer at the diamond surface became so wide that ohmic-tunnelling through it could not occur anymore.

It is now also clear why, after the measurements with the positive potential, conduction with a negative potential could occur at a gap distance of $1 \mu\text{m}$ (see figure 2). There were still enough electrons outside the diamond to establish a superconducting state. However, as the gap was increased further, the current fell away because the metal probe is not an NEA, n-type semiconductor that is able to add more electrons by increasing the width of a positively charged depletion layer at its surface. As already discussed above, the charged layer just below the anode surface should be negative.

In conclusion, it should be noted that the effect of higher temperatures on the stability of the superconducting phase has not been studied. One could argue that at some higher temperature the differences in energy between the electrons within the gap could become so large that the conditions required for the phase transition to a superconducting state cannot be reached. On the other hand, it should also be noted that once the electrons have condensed, it is difficult to envisage a method that could be used to measure the temperature of this new phase. One may just as well ask what is the temperature of a laser beam in which the photons are all at the same energy. The only relevant temperatures seem to be those of the diamond cathode and the anode probe. Accordingly, the temperature at which the superconducting phase ceases to exist is most probably determined by the interface properties between the diamond-to-vacuum and vacuum-to-anode: for example, when the cold cathode starts to act like a hot cathode, where the electrons form a thermally-generated space charge region described by Maxwell–Boltzmann statistics. Unfortunately, the experimental arrangement used for the measurements reported above could not be used to make accurate measurements to very high temperatures. However, by allowing the current through the diamond to heat it, it has been found that the superconducting phase was still stable at diamond temperatures as high as 50 to 80 °C.

5. Conclusion

The results measured in this study can be consistently modelled by postulating that

1. n-type doped diamond is an inherent negative electron affinity material, even without hydrogen on its surface.
2. By generating an ‘ohmic’-tunnelling contact between an n-type doped diamond and the vacuum, electrons can be extracted from the diamond. The electrons being extracted into the gap between the diamond and the anode are able to form a stable, highly conducting phase. The formation of this phase is inevitable because according to the accepted theories which describe electron transport in a vacuum and through a semiconductor interface, the extracted electrons must increase in density, while at the same time, the energy differences between them must decrease until a Bose–Einstein-type of condensation has to occur. Furthermore, the boson-like charge carriers needed to form such a condensate automatically ensue when the electron density reaches a value above which it will violate the Heisenberg uncertainty relationship. This results in the formation of a stable phase at room temperature, which has to be superconducting.

Acknowledgments

It is a pleasure to acknowledge the expert technical assistance that has been provided by Mik Rebak and Henk van Heerden. Mervin Naidoo performed the XPS measurements. This study forms part of a project on Ion-Implantation for Diamond Electronics, which had been funded by De Beers Industrial Diamonds (Pty) Ltd.

References

- [1] Himpsel F J, Knapp J A, van Vechten J A and Eastman D E 1979 *Phys. Rev. B* **20** 624
- [2] Prins J F 2003 *Semicond. Sci. Technol.* **18** 125
- [3] Geis M W, Twichell J C, Macaulay J and Okano K 1995 *Appl. Phys. Lett.* **67** 1328
- [4] Okano K, Koizumi S, Ravi S, Silva P and Amaratunga G A J 1996 *Nature* **381** 140
- [5] Nemanich R J, Köch F A M, English S L and Sowers A T 2000 *Diamond Materials VI* ed J L Davidson, J C Angus, W D Brown, A Gicquel, B V Spitsyn, G M Swain and W B Kang (Pennington, NJ: Electrochemical Soc.) pp 206–15
- [6] Kimura C, Koizumi S, Kamo M and Sugino T 1999 *Diamond Relat. Mater.* **8** 759
- [7] Prins J F 2000 *Phys. Rev. B* **61** 7191
- [8] Prins J F 2000 *Diamond Relat. Mater.* **9** 1275
- [9] Prins J F 2001 *Semicond. Sci. Technol.* **16** L50
- [10] Ziegler J F, Biersack J P and Littmark U 1985 *The Stopping and Range of Ions in Solids* (New York: Pergamon)
- [11] Prins J F 1998 *Diamond Relat. Mater.* **7** 545
- [12] Prins J F, Rebak M and van Heerden H J 2002 Unpublished
- [13] Prins J F 1989 *J. Phys. D: Appl. Phys.* **22** 1562
- [14] Uman M F 1974 *Introduction to the Physics of Electronics* (Englewood Cliffs, NJ: Prentice Hall) pp 99–100
- [15] Kittel C 1971 *Introduction to Solid State Physics* (New York: Wiley) p 324
- [16] Einstein A 1925 *Sitzungber. Preuss. Akad. Wiss.* **1925** 3
- [17] Bardeen J, Cooper L N and Schrieffer J R 1957 *Phys. Rev.* **108** 1175
- [18] Feynman R P, Leighton R B and Sands M 1965 *The Feynman Lectures on Physics vol. III: Quantum Mechanics* (Reading, MA: Addison-Wesley) p 4/14
- [19] Greiner W 1994 *Quantum Mechanics: An Introduction* (New York: Springer) pp 47–50