Theory of Superconductivity

© Carsten Timm 2020

Version: April 22, 2026

Contents

1	Introduction	5
1.1	Scope and overview	5
1.2	Books	6
2	Basic experiments	7
2.1	Conventional superconductors	7
2.2	Superfluid helium	9
2.3	Unconventional superconductors	11
2.4	Bose-Einstein condensation in dilute gases	12
3	Bose-Einstein condensation	14
4	Normal metals	19
4.1	Electrons in metals	19
4.2	Semiclassical theory of transport	20
5	Electrodynamics of superconductors	24
5.1	London theory	24
5.2	Rigidity of the superfluid state	26
5.3	Flux quantization	27
5.4	Nonlocal response: Pippard theory	28
6	Ginzburg-Landau theory	31
6.1	Landau theory of phase transitions	31
6.2	Ginzburg-Landau theory for neutral superfluids	34
6.3	Ginzburg-Landau theory for superconductors	40
6.4	Type-I superconductors	44
6.5	Type-II superconductors	47
7	Superfluid and superconducting films	55
7.1	Superfluid films	55
7.2	Superconducting films	68
8	Origin of the attractive interaction	74
8.1	Reminder on Green functions	74
8.2	Coulomb interaction	77
8.3	Electron-phonon interaction	81
8.4	Effective interaction between electrons	83
9	Cooper instability and BCS ground state	86
9.1	Cooper instability	86
9.2	The BCS ground state	89

10 BCS theory	94
10.1 BCS mean-field theory	94
10.2 Minimization of the free energy	100
10.3 Richardson's solution of the BCS model	105
10.4 Photoemission	106
10.5 Isotope effect	107
10.6 Specific heat	108
10.7 Density of states and single-particle tunneling	110
10.8 Ultrasonic attenuation and nuclear relaxation	115
10.9 Ginzburg-Landau-Gor'kov theory	119
11 Josephson effects	121
11.1 The Josephson effects in Ginzburg-Landau theory	121
11.2 Dynamics of Josephson junctions	123
11.3 The Bogoliubov-de Gennes Hamiltonian	127
11.4 Andreev reflection	129
12 Unconventional pairing	135
12.1 The gap equation for unconventional pairing	135
12.2 Cuprates	139
12.3 Pnictides	146
12.4 Triplet superconductors and He-3	148
12.5 Noncentrosymmetric superconductors	151

1

Introduction

1.1 Scope and overview

Superconductivity is characterized by a vanishing static electrical resistivity and an expulsion of the magnetic field from the interior of a sample. We will discuss these basic experiments in the following chapter, but mainly this course is dealing with the *theory* of superconductivity. We want to understand superconductivity using methods of theoretical physics. Experiments will be mentioned if they motivate certain theoretical ideas or support or contradict theoretical predictions, but a systematic discussion of experimental results will not be given.

Superconductivity is somewhat related to the phenomena of *superfluidity* (in He-3 and He-4) and *Bose-Einstein condensation* (in weakly interacting boson systems). The similarities are found to lie more in the effective low-energy description than in the microscopic details. Microscopically, superfluidity in He-3 is most closely related to superconductivity since both phenomena involve the condensation of *fermions*, whereas in He-4 and, of course, Bose-Einstein condensates it is *bosons* that condense. We will discuss these phenomena briefly.

<i>fermions</i>	<i>bosons</i>
superconductivity	superfluidity in He-4
superfluidity in He-3	Bose-Einstein condensation

After reviewing the basic experiments and Bose-Einstein condensation, we will discuss the electrodynamics of superconductors. Then we will introduce the phenomenological Ginzburg-Landau theory for neutral superfluids and for superconductors, which will naturally lead to the Anderson-Higgs mechanism. Ginzburg-Landau theory already allows to understand many phenomena, as we will demonstrate by describing vortices. Vortices in thin films can be created as thermal excitations and can form bound pairs, which leads to the Berezinskii-Kosterlitz-Thouless theory of the phase transition in such films.

Turning to the microscopic description of superconductivity, we will examine the origin of the attractive electron-electron interaction in conventional superconductors. This will form the basis for understanding the Cooper instability of the normal Fermi sea and for the Bardeen-Cooper-Schrieffer (BCS) theory of superconductivity. With this theory in hand, we will discuss experimental consequences, e.g., in thermodynamics, single-particle tunneling, and nuclear relaxation. Then we will turn to pair tunneling and Josephson effects. To improve our theoretical toolbox, we will introduce the Bogoliubov-de Gennes equation for inhomogeneous superconductors. The final chapters will be devoted to unconventional superconductors, for example cuprates and pnictides, to Andreev scattering and Andreev bound states, and to topological superconductors.

The course assumes knowledge of the standard material from electrodynamics, quantum mechanics I, and thermodynamics and statistics. We will also use the second-quantization formalism (creation and annihilation operators), which are usually introduced in quantum mechanics II. A prior course on introductory solid state physics would be useful but is not required. Formal training in many-particle theory is not required, necessary concepts and methods will be introduced (or recapitulated) as needed.

1.2 Books

There are many textbooks on superconductivity and it is recommended to browse a few of them. None of them covers all the material of this course. M. Tinkham's *Introduction to Superconductivity* (McGraw-Hill, 2nd edition, 1996) is well written and probably has the largest overlap with this course.

A much broader, deeper, and more modern book is *Superfluid States of Matter* by B. Svistunov, E. Babaev, and N. Prokof'ev (CRC Press, 2015). It certainly goes beyond this course in many places.

A classic book is J. R. Schrieffer's *Theory of Superconductivity* (Addison-Wesley, 1983). It is deeper than Tinkham's book. Schrieffer uses methods from many-particle theory, which are, however, introduced in the book. The presentation is not always pedagogical.

Many books on solid-state theory or on many-particle theory contain chapters on superconductivity at various levels. One of them is *Many-Body Quantum Theory in Condensed Matter Physics* by H. Bruus and K. Flensberg (Oxford University Press, 2004). The authors use a modern, pedagogical style. The book mainly uses Green-function methods. Another excellent text is *Condensed Matter Field Theory* by A. Altland and B. D. Simons (Cambridge University Press, 2010). It introduces the BCS theory of superconductivity both in the conventional way, like in this lecture, and within the functional-integral formalism. The discussion is modern and lucid. There is also a section on Berezinskii-Kosterlitz-Thouless theory.

2

Basic experiments

In this chapter we will review the essential experiments that have established the presence of superconductivity, superfluidity, and Bose-Einstein condensation in various materials classes. Experimental observations that have helped to elucidate the detailed properties of the superconductivity or superfluidity in specific systems are not covered; some of them are discussed in later chapters.

2.1 Conventional superconductors

After H. Kamerlingh Onnes had managed to liquify Helium, it became possible to reach temperatures low enough to achieve superconductivity in some chemical elements. In 1911, he found that the static (dc) resistivity of mercury abruptly fell to zero at a *critical temperature* T_c of about 4.1 K.

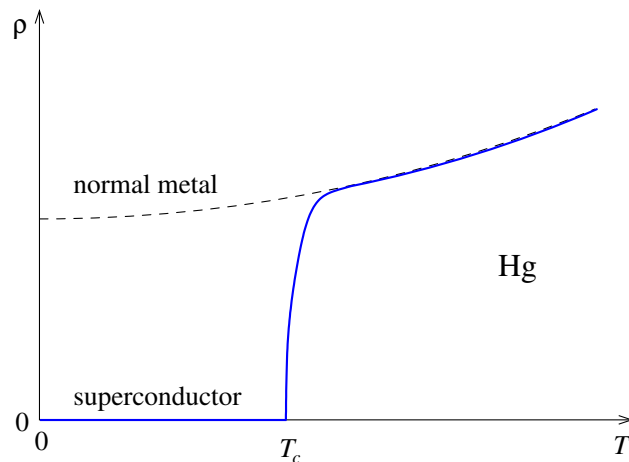

In a normal metal, the resistivity decreases with decreasing temperature but saturates at a finite value for $T \rightarrow 0$. The most stringent bounds on the resistivity can be obtained not from direct measurement but from the decay of persistent currents, or rather from the lack thereof. A current set up (by induction) in a superconducting ring is found to persist without measurable decay after the electromotive force driving the current has been switched off.

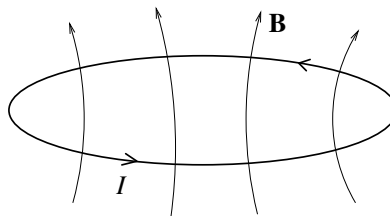

Assuming exponential decay, $I(t) = I(0)e^{-t/\tau}$, a lower bound on the decay time τ is found. From this, an upper bound of $\rho \lesssim 10^{-26} \Omega\text{m}$ has been extracted for the resistivity (File and Mills, 1963). For comparison, the resistivity of copper at room temperature is $\rho_{\text{Cu}} \approx 1.7 \times 10^{-8} \Omega\text{m}$.

The *second essential observation* was that superconductors not only prevent a magnetic field from entering—but this will be discussed in Sec. 5.1—but actively *expel* the magnetic field from their interior. This was observed by W. Meißner and R. Ochsenfeld in 1933 and is now called the *Meißner* or *Meißner-Ochsenfeld effect*.

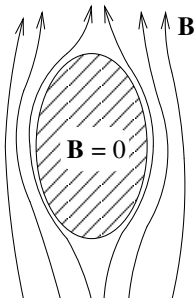

From the materials relation $\mathbf{B} = \mu\mathbf{H}$ with the permeability $\mu = 1 + 4\pi\chi$ and the magnetic susceptibility χ (note that we are using *Gaussian units*) we thus find $\mu = 0$ and $\chi = -1/4\pi$. Superconductors are diamagnetic since $\chi < 0$. What is more, they realize the smallest (most diamagnetic) value of μ consistent with thermodynamic stability.¹ The field is not just diminished but completely expelled. They are thus *perfect diamagnets*.

It costs energy to make the magnetic field nonuniform although the externally applied field is uniform. It is plausible that at some externally applied magnetic field $H_c(T) \equiv B_c(T)$ this cost will be so high that there is no advantage in forming a superconducting state. For typical *conventional* superconductors, the experimental phase diagram in the temperature-magnetic field plane looks like this:

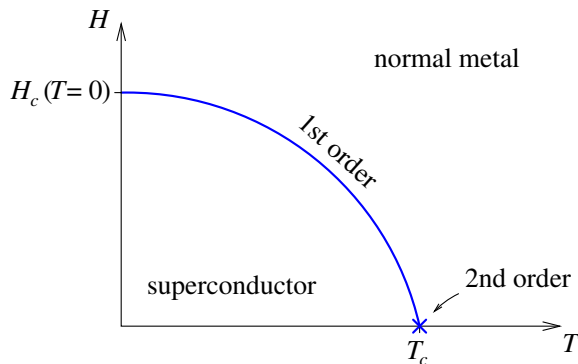

To specify which superconductors discovered after Hg are conventional, we need a definition of what we want to call “conventional superconductors.” There are at least two inequivalent but often coinciding definitions: Conventional superconductors

- show a superconducting state of trivial symmetry (essentially, the superconductor does not break any symmetry beyond a global U(1) phase symmetry),

¹An argument for why μ cannot be negative goes as follows: with a suitably defined free energy F and the volume V one has

$$\mathbf{H} = \frac{4\pi}{V} \frac{\partial F}{\partial \mathbf{B}}.$$

Within the range of validity of linear-response theory, we have $\mathbf{H} = \mathbf{B}/\mu$ (if $\mu \neq 0$) and thus

$$\mathbf{B} = \frac{4\pi\mu}{V} \frac{\partial F}{\partial \mathbf{B}}.$$

This implies

$$F(\mathbf{B}) = F(0) + \frac{V}{8\pi\mu} B^2$$

so that $\mu < 0$ would make the free energy unbounded from below.

- result from an attractive interaction between electrons in which phonons play a dominant role.

Conventional superconductivity was observed in quite a lot of elements at low temperatures. The record critical temperature for elements are $T_c = 9.3$ K for Nb under ambient pressure and $T_c = 29$ K for Ca under high pressure. Superconductivity is in fact rather common in the periodic table, about 53 pure elements show it under some conditions. Many alloys and intermetallic compounds were also found to show conventional superconductivity according to the above criteria. Of these, for a long time Nb₃Ge had the highest known T_c of 23.2 K. But it is now thought that MgB₂ ($T_c = 39$ K, discovered to be superconducting in 2001) and a few related compounds are also conventional superconductors in the above sense. They nevertheless show some interesting properties. The rather high $T_c = 39$ K of MgB₂ is interesting since it is on the order of the maximum $T_c^{\text{max}} \approx 30$ K that was originally expected for phonon-driven superconductivity. To increase T_c further, the interaction between electrons and phonons would have to be stronger. However, it was thought that stronger interactions would make the material unstable towards a charge density wave. MgB₂ would thus be an “optimal” conventional superconductor.

Superconductivity with comparably high T_c has also been found in fullerites, i.e., compounds containing fullerene anions. The record T_c in this class is at present $T_c = 38$ K for body-centered cubic Cs₃C₆₀ under pressure. Superconductivity in fullerites was originally thought to be driven by phonons with strong molecular vibration character but there is recent evidence that it might be unconventional (not phonon driven).

The received wisdom was challenged by the discovery of superconductivity in hydrogen sulfide at up to 203 K under a high pressure of above 150 GPa (corresponding to about 1.5 million standard atmospheres), see Drozdov *et al.*, Nature **525**, 73 (2015). The responsible compound is thought to be H₃S forming a body-centered cubic lattice. Amazingly, superconductivity in this system appears to be phonon driven and in this sense conventional. The presence of the light hydrogen atoms is crucial for this. That H atoms could favor superconductivity at high temperatures was already proposed by N. W. Ashcroft in 1968. There is an ongoing search for high- T_c superconductivity in other hydrogen compounds. Recently, this effort has led to the discovery of superconductivity with $T_c \approx 250$ K in LaH₁₀ at high pressure, see Drozdov *et al.*, Nature **569**, 528 (2019). The material is a clathrate, in which the metal atom is surrounded by a cage of hydrogen atoms.

2.2 Superfluid helium

In 1937, P. Kapiza and independently Allen and Misener discovered that helium shows a transition at $T_c = 2.17$ K under ambient pressure, below which it flows through narrow capillaries without resistance. The analogy to superconductivity is obvious but here it was the *viscosity* instead of the resistivity that dropped to zero. The phenomenon was called *superfluidity*. It was also observed that due to the vanishing viscosity an open container of helium would empty itself through a flow in the microscopically thin wetting layer.

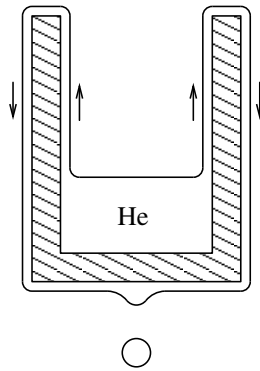

On the other hand, while part of the liquid flows with vanishing viscosity, another part does not. This was shown using torsion pendulums of plates submerged in helium. A temperature-dependent *normal* component oscillates with the plates.

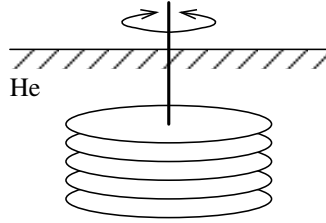

Natural atmospheric helium consists of 99.9999% He-4 and only 0.0001% He-3, the only other stable isotope. The observed properties are thus essentially indistinguishable from those of pure He-4. He-4 atoms are bosons since they consist of an even number (six) of fermions. For weakly interacting bosons, A. Einstein predicted in 1925 that a phase transition to a condensed phase should occur (*Bose-Einstein condensation*). The observation of superfluidity in He-4 was thus not a surprise—in contrast to the discovery of superconductivity—but in many details the properties of He-4 were found to differ from the predicted Bose-Einstein condensate. The reason for this is that the interactions between helium atoms are actually quite strong. For completeness, we sketch the temperature-pressure phase diagram of He-4:

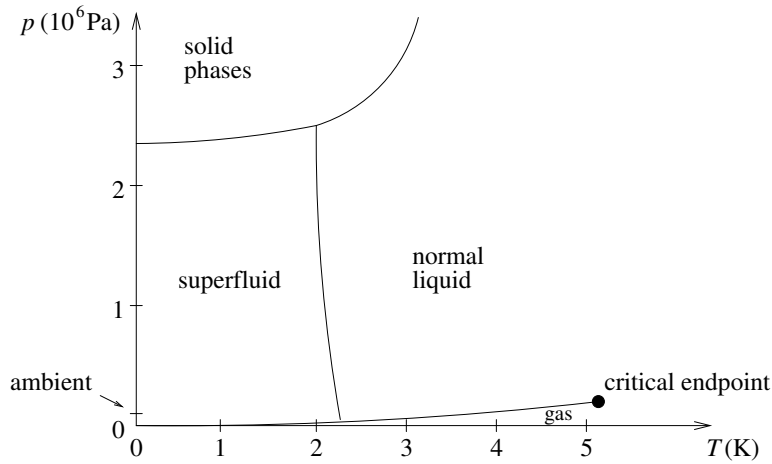

The other helium isotope, He-3, consists of *fermionic* atoms so that Bose-Einstein condensation cannot take place. Indeed no superfluid transition was observed in the temperature range of a few Kelvin. It then came as a big surprise when superfluidity was finally observed at much lower temperatures below about 2.6 mK by D. Lee, D. Osheroff, and R. Richardson in 1972. In fact they found *two* new phases at low temperatures. (They originally misinterpreted them as possible magnetic solid phases.) Here is a sketch of the phase diagram, note the temperature scale:

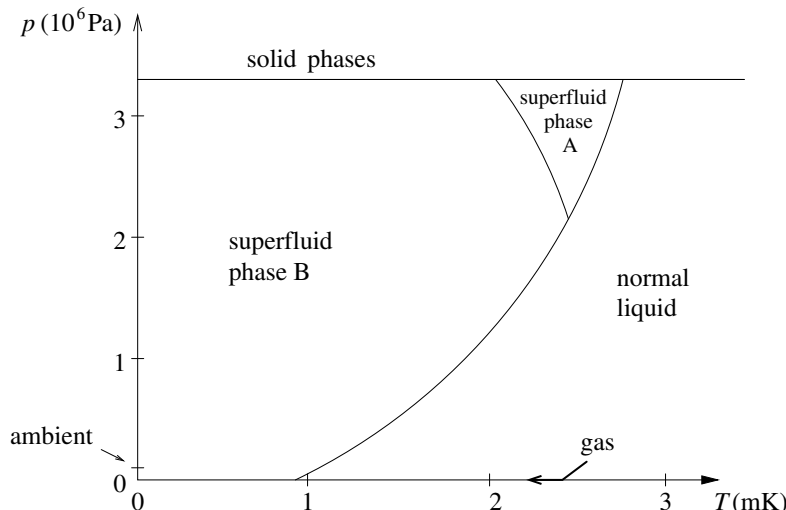

Superfluid He-3 shows the same basic properties as He-4. But unlike in He-4, the two superfluid states are sensitive to an applied magnetic field, suggesting the presence of magnetic degrees of freedom at low energies.

2.3 Unconventional superconductors

By the late 1970's, superconductivity seemed to be a more or less closed subject. It was well understood based on the BCS theory and extensions thereof that dealt with strong interactions. It only occurred at temperatures up to 23.2 K (Nb₃Ge) and thus did not promise widespread technological application. It was restricted to non-magnetic metallic elements and simple compounds. This situation started to change dramatically in 1979. Since then, superconductivity has been observed in various materials classes that are very different from each other and from the typical low- T_c superconductors known previously. In many cases, the superconductivity is unconventional and often T_c is rather high. We now give a brief and incomplete historical overview.

- In 1979, Frank Steglich *et al.* observed superconductivity below $T_c \approx 0.5$ K in CeCu₂Si₂. This material is not a normal metal in its normal state. Instead it is a *heavy-fermion* material. The electrons at the Fermi energy have strong Ce *f*-orbital character. The very strong Coulomb repulsion between electrons in the *f*-shell leads to a large effective mass $m^* \gg m_e$ at the Fermi energy, hence the name. (The small overlap between localized *f* orbitals also contributes to the large mass but interactions are crucial.) Since then, superconductivity has been found in various other heavy-fermion compounds. BCS theory has difficulties to explain superconductivity in these highly correlated metals. Nuclear magnetic resonance (discussed below) and other experimental techniques have shown that many of these heavy-fermion superconductors show unconventional symmetry of the superconducting state.
- Also in 1979, D. Jérôme *et al.* (Klaus Bechgaard's group) observed superconductivity in an organic salt called (TMTSF)₂PF₂ with $T_c = 1.1$ K. Superconductivity has since been found in various organic materials with a maximum T_c of about 18 K. The symmetry of the superconducting state is often unconventional. (We do not include fullerenes under organic compounds since they lack hydrogen atoms.)
- While the previously mentioned discoveries showed that superconductivity can occur in unexpected materials classes and probably due to unconventional mechanisms, the T_c values did not surpass the $T_c \approx 23$ K of Nb₃Ge. In 1986, J. G. Bednorz and K. A. Müller observed superconductivity in La_{2-x}Ba_xCuO₄ (the layered perovskite cuprate La₂CuO₄ with some Ba substituted for La) with T_c on the order of 35 K. In the following years, many other superconductors based on the same type of nearly flat CuO₂ planes sketched below were discovered. The record transition temperatures for cuprates are $T_c = 138$ K for Hg_{0.8}Tl_{0.2}Ba₂Ca₂Cu₃O_{8+δ} at ambient pressure and $T_c = 164$ K for HgBa₂Ca₂Cu₃O_{8+δ} under high pressure. Many experimental probes show that the cuprates are unconventional superconductors. High- T_c superconductivity in the cuprates was historically important since many advanced methods of many-body theory have been developed motivated by the desire to understand this phenomenon. We will come back to this materials class below.

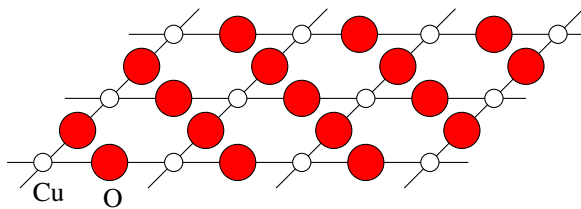

- In 1991, A. F. Hebard *et al.* found that the fullerite $\text{K}_3\text{C}_{60} = (\text{K}^-)_3\text{C}_{60}^{3-}$ became superconducting below $T_c = 18\text{ K}$. T_c in this class has since been pushed to $T_c = 33\text{ K}$ for $\text{Cs}_2\text{RbC}_{60}$ at ambient pressure and $T_c = 38\text{ K}$ for (b.c.c., while all the other known superconducting fullerenes are f.c.c.) Cs_3C_{60} under high pressure. The symmetry of the superconducting state appears to be trivial but, as noted above, there is an ongoing debate on whether the pairing is phonon-mediated.
- In 1994, Maeno *et al.* discovered superconductivity in Sr_2RuO_4 with $T_c \approx 1.5\text{ K}$. The (perovskite) lattice structure is the same as for the earliest studied cuprates, such as doped La_2CuO_4 , but with copper replaced by ruthenium. The superconducting state appears to be magnetic and was long thought to be similar to the superfluid states of He-3. Very recent experiments cast doubt upon this picture but superconductivity in Sr_2RuO_4 is certainly unconventional.
- In 2001, Nagamatsu *et al.* reported superconductivity in MgB_2 with $T_c = 39\text{ K}$. The high T_c and the layered crystal structure, reminiscent of cuprates, led to the expectation that superconductivity in MgB_2 is unconventional. However, most experts now think that it is actually conventional, as noted above.
- A new series of important discoveries started in 2006, when Kamihara *et al.* (H. Hosono's group) observed superconductivity with $T_c \approx 4\text{ K}$ in LaFePO , another layered compound. While this result added a new materials class based on Fe^{2+} to the list of superconductors, it did not yet cause much excitement due to the low T_c . However, in 2008, Kamihara *et al.* (the same group) found superconductivity with $T_c \approx 26\text{ K}$ in $\text{LaFeAsO}_{1-x}\text{F}_x$. Very soon thereafter, the maximum T_c in this *iron-pnictide* class was pushed to 55 K . Superconductivity was also observed in several related materials classes, some of them not containing oxygen (e.g., LiFeAs) and some with the pnictogen (As) replaced by a chalcogen (e.g., FeSe). The common structural element is a flat, square Fe^{2+} layer with a pnictogen or chalcogen sitting alternately above and below the centers of the Fe squares. Superconductivity is thought to be unconventional. The mechanism is not necessarily the same for all members of this diverse family.

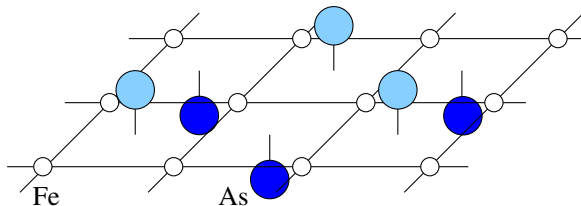

- Drozdov *et al.* reported superconductivity in H_3S under high pressure with a maximum critical temperature of $T_c = 203\text{ K}$ in 2015 and in LaH_{10} under high pressure with $T_c \approx 250\text{ K}$ in 2019, as noted above. Although not completely understood yet, superconductivity is thought to be due to phonons and in this sense conventional.

2.4 Bose-Einstein condensation in dilute gases

An important related breakthrough was the realization of a Bose-Einstein condensate (BEC) in a highly diluted and very cold gas of atoms. In 1995, Anderson *et al.* (C. E. Wieman and E. A. Cornell's group) reported condensation in a dilute gas of Rb-87 below $T_c = 170\text{ nK}$ (!). Only a few months later, Davis *et al.* (W. Ketterle's group) reported a BEC of Na-23 containing many more atoms. About a year later, the same group was able to create two condensates and then merge them. The resulting *interference effects* showed that the atoms were really in a macroscopic quantum state, i.e., a condensate. All observations are well understood from the picture of a weakly interacting Bose gas. Bose-Einstein condensation will be reviewed in the following chapter.

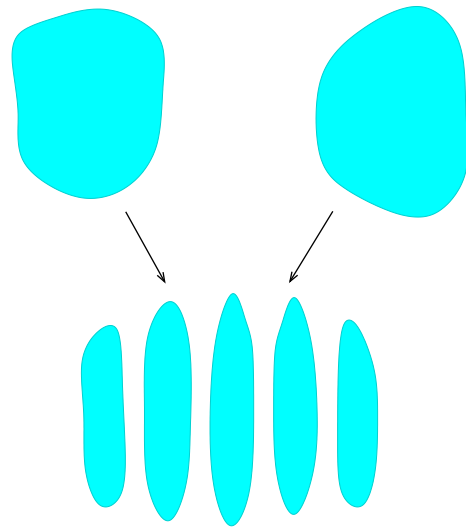

3

Bose-Einstein condensation

In this short chapter we review the theory of Bose-Einstein condensation. While this is not the correct theory for superconductivity, at least in most superconductors, it is the simplest description of a *macroscopic quantum condensate*. This concept is central also for superconductivity and superfluidity.

We consider an *ideal gas of indistinguishable bosons*. “Ideal” means that we neglect any interaction between the particles. There are two cases with completely different behavior depending on whether the particle number is conserved or not. Rb-87 atoms are bosons (they consist of 87 nucleons and 37 electrons) with conserved particle number, whereas photons are bosons with non-conserved particle number. Photons can be freely created and destroyed as long as the usual conservation laws (energy, momentum, angular momentum, ...) are satisfied. Bosons without particle-number conservation show a Planck distribution,

$$n_P(E) = \frac{1}{e^{\beta E} - 1} \quad (3.1)$$

with $\beta := 1/k_B T$, for a grand-canonical ensemble in equilibrium. Note the absence of a chemical potential, which is due to the non-conservation of the particle number. This distribution function is an analytical function of temperature and thus does not show any phase transitions.

The situation is different for bosons with conserved particle number. We want to consider the case of a given number N of particles in contact with a heat bath at temperature T . This calls for a *canonical* description (N, T given). However, it is easier to use the *grand-canonical* ensemble with the chemical potential μ given. For large systems, fluctuations of the particle number become small so that the descriptions are equivalent. However, μ must be calculated from the given N .

The grand-canonical partition function is

$$\mathcal{Z} = \prod_i \left(1 + e^{-\beta(\epsilon_i - \mu)} + e^{-2\beta(\epsilon_i - \mu)} + \dots \right) = \prod_i \frac{1}{1 - e^{-\beta(\epsilon_i - \mu)}}, \quad (3.2)$$

where i counts the single-particle states of energy ϵ_i in a volume V . The form of \mathcal{Z} expresses that every state can be occupied not at all, once, twice, etc. For simplicity, we assume the volume to be a cube with periodic boundary conditions. Then the states can be enumerated by wave vectors \mathbf{k} compatible with these boundary conditions. Introducing the *fugacity*

$$y := e^{\beta\mu}, \quad (3.3)$$

we obtain

$$\mathcal{Z} = \prod_{\mathbf{k}} \frac{1}{1 - ye^{-\beta\epsilon_{\mathbf{k}}}} \quad (3.4)$$

$$\Rightarrow \ln \mathcal{Z} = \sum_{\mathbf{k}} \ln \frac{1}{1 - ye^{-\beta\epsilon_{\mathbf{k}}}} = - \sum_{\mathbf{k}} \ln (1 - ye^{-\beta\epsilon_{\mathbf{k}}}). \quad (3.5)$$

The fugacity has to be chosen to give the correct particle number

$$N \stackrel{!}{=} \sum_{\mathbf{k}} \langle n_{\mathbf{k}} \rangle = \sum_{\mathbf{k}} \frac{1}{e^{\beta(\epsilon_{\mathbf{k}} - \mu)} - 1} = \sum_{\mathbf{k}} \frac{1}{y^{-1} e^{\beta \epsilon_{\mathbf{k}}} - 1}. \quad (3.6)$$

Since $\langle n_{\mathbf{k}} \rangle$ must be non-negative, μ must satisfy

$$\mu \leq \epsilon_{\mathbf{k}} \quad \forall \mathbf{k}. \quad (3.7)$$

For a free particle, $\epsilon_{\mathbf{k}} = k^2/2m$ and the lowest possible eigenenergy is $\epsilon_{\mathbf{k}} = 0$ for $\mathbf{k} = 0$ so that we obtain $\mu \leq 0$ and thus $y \leq 1$.

For a large volume V , the allowed vectors \mathbf{k} become dense and we can replace the sums over \mathbf{k} by integrals according to

$$\sum_{\mathbf{k}} \dots \rightarrow V \int \frac{d^3 k}{(2\pi)^3} \dots = \frac{2\pi V}{h^3} (2m)^{3/2} \int_0^{\infty} d\epsilon \sqrt{\epsilon} \dots \quad (3.8)$$

In the last equation we have used the density of states (DOS) of free particles in three dimensions. Note that the DOS would be different for a different number of dimensions. For example, in two dimensions, the DOS scales as $\epsilon^0 = 1$. The DOS is also different if one assumes a harmonic instead of a square-well confining potential. The replacement in Eq. (3.8) contains a fatal mistake, though. The DOS for $\epsilon = 0$ vanishes so that any particles in the state with $\mathbf{k} = 0$, $\epsilon_{\mathbf{k}} = 0$ do not contribute to the results. But that is the ground state! For $T = 0$ *all* bosons should be in this state. We thus expect incorrect results at low temperatures.

Our mistake was that Eq. (3.8) does not hold if the fraction of bosons in the $\mathbf{k} = 0$ ground state is macroscopic, i.e., if $N_0/N := \langle n_0 \rangle / N$ remains finite for large V . To correct this, we treat the $\mathbf{k} = 0$ state explicitly (the same would be necessary for any state with macroscopic occupation). We write

$$\sum_{\mathbf{k}} \dots \rightarrow \frac{2\pi V}{h^3} (2m)^{3/2} \int_0^{\infty} d\epsilon \sqrt{\epsilon} \dots + (\mathbf{k} = 0 \text{ term}). \quad (3.9)$$

Note that splitting off the ground state would be not just unnecessary but incorrect for a two-dimensional gas. Treating the ground state explicitly, we obtain

$$\ln \mathcal{Z} = -\frac{2\pi V}{h^3} (2m)^{3/2} \int_0^{\infty} d\epsilon \sqrt{\epsilon} \ln(1 - ye^{-\beta\epsilon}) - \ln(1 - y) \stackrel{\text{by parts}}{=} \frac{2\pi V}{h^3} (2m)^{3/2} \frac{2}{3} \beta \int_0^{\infty} d\epsilon \frac{\epsilon^{3/2}}{y^{-1} e^{\beta\epsilon} - 1} - \ln(1 - y) \quad (3.10)$$

with

$$N = \frac{2\pi V}{h^3} (2m)^{3/2} \int_0^{\infty} d\epsilon \sqrt{\epsilon} \frac{1}{y^{-1} e^{-\beta\epsilon} - 1} + \frac{1}{y^{-1} - 1} = \frac{2\pi V}{h^3} (2m)^{3/2} \int_0^{\infty} d\epsilon \frac{\sqrt{\epsilon}}{y^{-1} e^{-\beta\epsilon} - 1} + \frac{y}{1 - y}. \quad (3.11)$$

Defining

$$g_n(y) := \frac{1}{\Gamma(n)} \int_0^{\infty} dx \frac{x^{n-1}}{y^{-1} e^x - 1} \quad (3.12)$$

for $0 \leq y \leq 1$ and $n \in \mathbb{R}$, and the thermal wavelength

$$\lambda := \sqrt{\frac{h^2}{2\pi m k_B T}}, \quad (3.13)$$

we obtain

$$\ln \mathcal{Z} = \frac{V}{\lambda^3} g_{5/2}(y) - \ln(1 - y), \quad (3.14)$$

$$N = \underbrace{\frac{V}{\lambda^3} g_{3/2}(y)}_{=: N_\epsilon} + \underbrace{\frac{y}{1-y}}_{=: N_0}. \quad (3.15)$$

We note the identity

$$g_n(y) = \sum_{k=1}^{\infty} \frac{y^k}{k^n}, \quad (3.16)$$

which implies

$$g_n(0) = 0, \quad (3.17)$$

$$g_n(1) = \sum_{k=1}^{\infty} \frac{1}{k^n} \equiv \zeta(n) \quad \text{for } n > 1 \quad (3.18)$$

with the Riemann zeta function $\zeta(x)$. Furthermore, $g_n(y)$ increases monotonically in y for $y \in [0, 1[$.

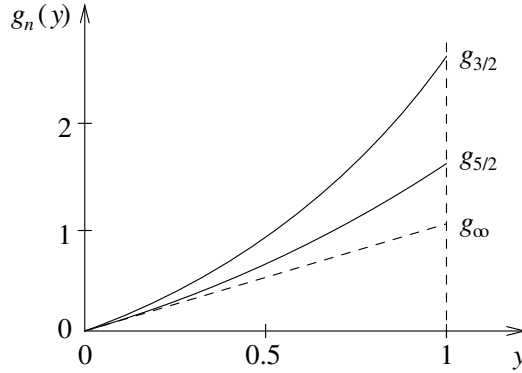

We now have to eliminate the fugacity y from Eqs. (3.14) and (3.15) to obtain \mathcal{Z} as a function of the particle number N . In Eq. (3.14), the first term is the number of particles in excited states ($\epsilon_{\mathbf{k}} > 0$), whereas the second term is the number of particles in the ground state. We consider two cases: 1. If y is not very close to unity (specifically, if $1-y \gg \lambda^3/V$), $N_0 = y/(1-y)$ is on the order of unity, whereas N_ϵ is an *extensive* quantity. Thus N_0 can be neglected and we get

$$N \cong N_\epsilon = \frac{V}{\lambda^3} g_{3/2}(y). \quad (3.19)$$

Since $g_{3/2} \leq \zeta(3/2) \approx 2.612$, this equation can only be solved for the fugacity y if the concentration satisfies

$$\frac{N}{V} \leq \frac{\zeta(3/2)}{\lambda^3}. \quad (3.20)$$

Note that the right-hand side decreases with decreasing temperature since $\lambda^3 \propto T^{-3/2}$ increases. Hence, below a critical temperature T_c , the inequality is no longer fulfilled. From

$$\frac{N}{V} \stackrel{!}{=} \frac{\zeta(3/2)}{\left(\frac{h^2}{2\pi m k_B T_c}\right)^{3/2}} \quad (3.21)$$

we obtain

$$k_B T_c = \frac{1}{[\zeta(3/2)]^{2/3}} \frac{h^2}{2\pi m} \left(\frac{N}{V}\right)^{2/3}. \quad (3.22)$$

2. If, on the other hand, y is very close to unity, i.e., $1-y \lesssim \lambda^3/V$, N_0 cannot be neglected. Moreover, in this case we find

$$N_\epsilon = \frac{V}{\lambda^3} g_{3/2}(y) = \frac{V}{\lambda^3} g_{3/2}(1 - \mathcal{O}(\lambda^3/V)), \quad (3.23)$$

where $\mathcal{O}(\lambda^3/V)$ is a correction of order $\lambda^3/V \ll 1$. Thus, by Taylor expansion,

$$N_\epsilon = \frac{V}{\lambda^3} g_{3/2}(1) - \mathcal{O}(1) = \frac{V}{\lambda^3} \zeta(3/2) - \mathcal{O}(1). \quad (3.24)$$

The *intensive* term $\mathcal{O}(1)$ can be neglected compared to the extensive one so that

$$N_\epsilon \cong \frac{V}{\lambda^3} \zeta(3/2). \quad (3.25)$$

This is the maximum possible value at temperature T . Furthermore, $N_0 = y/(1-y)$ is solved by

$$y = \frac{N_0}{N_0 + 1} = \frac{1}{1 + 1/N_0}. \quad (3.26)$$

For y to be very close to unity, N_0 must satisfy $N_0 \gg 1$. Since

$$N_0 = N - N_\epsilon \cong N - \frac{V}{\lambda^3} \zeta(3/2) \quad (3.27)$$

must be positive, we require

$$\frac{N}{V} > \frac{\zeta(3/2)}{\lambda^3} \quad (3.28)$$

$$\Rightarrow T < T_c. \quad (3.29)$$

We conclude that the fraction of particles in excited states is

$$\frac{N_\epsilon}{N} \cong \frac{V}{N\lambda^3} \zeta(3/2) = \frac{\lambda^3(T_c)}{\lambda^3(T)} = \left(\frac{T}{T_c}\right)^{3/2}. \quad (3.30)$$

The fraction of particles in the ground state is then

$$\frac{N_0}{N} \cong 1 - \left(\frac{T}{T_c}\right)^{3/2}. \quad (3.31)$$

In summary, we find in the thermodynamic limit

(a) for $T > T_c$:

$$\frac{N_\epsilon}{N} \cong 1, \quad \frac{N_0}{N} \ll 1, \quad (3.32)$$

(b) for $T < T_c$:

$$\frac{N_\epsilon}{N} \cong \left(\frac{T}{T_c}\right)^{3/2}, \quad \frac{N_0}{N} \cong 1 - \left(\frac{T}{T_c}\right)^{3/2}. \quad (3.33)$$

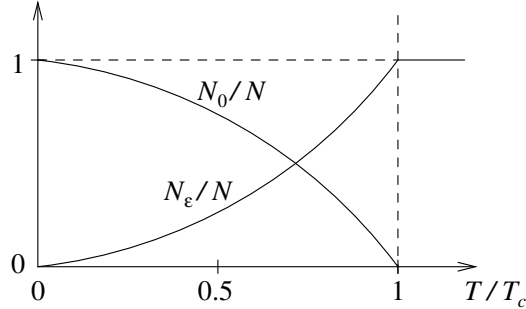

We find a phase transition at T_c , below which a *macroscopic fraction* of the particles occupy *the same* single-particle quantum state. This fraction of particles is said to form a *condensate*. While it is remarkable that Bose-Einstein condensation happens in a *non-interacting* gas, the BEC is analogous to the condensate in strongly interacting superfluid He-4 and, with some added twists, in superfluid He-3 and in superconductors.

We can now use the partition function to derive equations of state. As an example, we consider the pressure

$$\begin{aligned} p &= -\frac{\partial\Phi}{\partial V} = +\frac{\partial}{\partial V} k_B T \ln \mathcal{Z} \\ &= k_B T \frac{\partial}{\partial V} \left[\frac{V}{\lambda^3} g_{5/2}(y) - \ln(1-y) \right]. \end{aligned} \quad (3.34)$$

(Φ is the grand-canonical potential). In principle, the fugacity y depends on the volume V since we have to invert

$$N = \frac{V}{\lambda^3} g_{3/2}(y) + \frac{y}{1-y}, \quad (3.35)$$

which gives us $y(N, V)$. Derivatives with respect to V are taken at fixed particle number N . Thus we get

$$\begin{aligned} p &= \frac{k_B T}{\lambda^3} g_{5/2}(y) + k_B T \left[\frac{V}{\lambda^3} g'_{5/2}(y) + \frac{1}{1-y} \right] \frac{\partial y}{\partial V} \\ &= \frac{k_B T}{\lambda^3} g_{5/2}(y) + k_B T \left[\frac{V}{\lambda^3} \frac{g_{3/2}(y)}{y} + \frac{1}{1-y} \right] \frac{\partial y}{\partial V}. \end{aligned} \quad (3.36)$$

For $T > T_c$, we can find y and thus p numerically. For $T < T_c$ we may set $y = 1$ so that $\partial y / \partial V = 0$ and

$$p = \frac{k_B T}{\lambda^3} \zeta(5/2) \propto T^{5/2}. \quad (3.37)$$

Note that only the excited states contribute to the pressure. This is plausible since particles in the condensate have vanishing kinetic energy.

The result should be compared to the *classical* ideal gas. In that case the equation of state gives

$$p \propto T. \quad (3.38)$$

For the BEC, the pressure drops more rapidly since more and more particles condense and thus no longer contribute to the pressure.

4

Normal metals

To be able to appreciate the remarkable properties of superconductors, it is useful to review what we know about normal conductors.

4.1 Electrons in metals

Let us ignore electron-electron Coulomb interaction and deviations from a perfectly periodic crystal structure (due to defects or phonons) for now. Then the exact single-particle states are described by *Bloch wavefunctions*

$$\psi_{\alpha\mathbf{k}}(\mathbf{r}) = u_{\alpha\mathbf{k}}(\mathbf{r}) e^{i\mathbf{k}\cdot\mathbf{r}}, \quad (4.1)$$

where $u_{\alpha\mathbf{k}}(\mathbf{r})$ is a lattice-periodic function, α is the band index including the spin, and $\hbar\mathbf{k}$ is the crystal momentum in the first Brillouin zone. Since electrons are fermions, the average occupation number of the state $|\alpha\mathbf{k}\rangle$ with energy $\epsilon_{\alpha\mathbf{k}}$ is given by the Fermi-Dirac distribution function

$$n_F(\epsilon_{\alpha\mathbf{k}}) = \frac{1}{e^{\beta(\epsilon_{\alpha\mathbf{k}} - \mu)} + 1}. \quad (4.2)$$

If the electron number N , and not the chemical potential μ , is given, μ has to be determined from

$$N = \sum_{\alpha\mathbf{k}} \frac{1}{e^{\beta(\epsilon_{\alpha\mathbf{k}} - \mu)} + 1}, \quad (4.3)$$

cf. our discussion for ideal bosons. In the thermodynamic limit we again replace

$$\sum_{\mathbf{k}} \dots \rightarrow V \int \frac{d^3k}{(2\pi)^3} \dots \quad (4.4)$$

Unlike for bosons, this is harmless for fermions, since any state can at most be occupied once so that macroscopic occupation of the single-particle ground state cannot occur. Thus we find

$$\frac{N}{V} = \sum_{\alpha} \int \frac{dk^3}{(2\pi)^3} \frac{1}{e^{\beta(\epsilon_{\alpha\mathbf{k}} - \mu)} + 1}. \quad (4.5)$$

If we lower the temperature, the Fermi function n_F becomes more and more step-like. For $T \rightarrow 0$, all states with energies $\epsilon_{\alpha\mathbf{k}} \leq E_F := \mu(T \rightarrow 0)$ are occupied (E_F is the Fermi energy), while all states with $\epsilon_{\alpha\mathbf{k}} > E_F$ are empty. This *Fermi sea* becomes fuzzy for energies $\epsilon_{\alpha\mathbf{k}} \approx E_F$ at finite temperatures but remains well defined as long as $k_B T \ll E_F$. This is the case for most materials we will discuss.

The chemical potential, the occupations $n_F(\epsilon_{\alpha\mathbf{k}})$, and thus all thermodynamic variables are *analytic* functions of T and N/V . Thus there is no phase transition, unlike for bosons. *Free* fermions represent the special case with only a single band with dispersion $\epsilon_{\mathbf{k}} = \hbar^2 k^2 / 2m$. If we replace m by a material-dependent effective mass, this

gives a reasonable approximation for simple metals such as alkali metals. Qualitatively, the conclusions are much more general.

Lattice imperfections and interactions result in the Bloch waves $\psi_{\alpha\mathbf{k}}(\mathbf{r})$ not being exact single-particle eigenstates. (Electron-electron and electron-phonon interactions invalidate the whole idea of single-particle states.) However, if these effects are in some sense small, they can be treated perturbatively in terms of *scattering* of electrons between single-particle states $|\alpha\mathbf{k}\rangle$.

4.2 Semiclassical theory of transport

We now want to derive an expression for the current in the presence of an applied electric field. This is a question about the response of the system to an external perturbation. There are many ways to approach this type of question. If the perturbation is small, the response, in our case the current, is expected to be a linear function of the perturbation. This is the basic assumption of linear-response theory. In the framework of many-particle theory, linear-response theory results in the *Kubo formula* (see lecture notes on many-particle theory). We here take a different route. If the external perturbation changes slowly in time and space on atomic scales, we can use a semiclassical description. Note that the following can be derived cleanly as a limit of many-particle quantum theory.

The idea is to consider the *phase space distribution function* $\rho(\mathbf{r}, \mathbf{k}, t)$. This is a classical concept. From quantum mechanics we know that \mathbf{r} and $\mathbf{p} = \hbar\mathbf{k}$ are subject to the uncertainty principle $\Delta r \Delta p \geq \hbar/2$. Thus distribution functions ρ localized in a phase-space volume smaller than on the order of \hbar^3 violate quantum mechanics. On the other hand, if ρ is much broader, quantum effects should be negligible.

The *Liouville theorem* shows that ρ satisfies the continuity equation

$$\frac{\partial \rho}{\partial t} + \dot{\mathbf{r}} \cdot \frac{\partial \rho}{\partial \mathbf{r}} + \dot{\mathbf{k}} \cdot \frac{\partial \rho}{\partial \mathbf{k}} \equiv \frac{d\rho}{dt} = 0 \quad (4.6)$$

(phase-space volume is conserved under the classical time evolution). Assuming for simplicity a free-particle dispersion, we have the canonical (Hamilton) equations

$$\dot{\mathbf{r}} = \frac{\partial H}{\partial \mathbf{p}} = \frac{\mathbf{p}}{m} = \frac{\hbar\mathbf{k}}{m}, \quad (4.7)$$

$$\dot{\mathbf{k}} = \frac{1}{\hbar} \dot{\mathbf{p}} = -\frac{1}{\hbar} \frac{\partial H}{\partial \mathbf{r}} = -\frac{1}{\hbar} \nabla V = \frac{1}{\hbar} \mathbf{F} \quad (4.8)$$

with the Hamiltonian H and the force \mathbf{F} . Thus we can write

$$\left(\frac{\partial}{\partial t} + \frac{\hbar\mathbf{k}}{m} \cdot \frac{\partial}{\partial \mathbf{r}} + \frac{\mathbf{F}}{\hbar} \cdot \frac{\partial}{\partial \mathbf{k}} \right) \rho = 0. \quad (4.9)$$

This equation is appropriate for particles in the absence of any scattering. For electrons in a uniform and time-independent electric field we have

$$\mathbf{F} = -e\mathbf{E}. \quad (4.10)$$

Note that we always use the convention that $e > 0$. It is easy to see that then

$$\rho(\mathbf{r}, \mathbf{k}, t) = f\left(\mathbf{k} + \frac{e\mathbf{E}}{\hbar}t\right) \quad (4.11)$$

is a solution of Eq. (4.9) for *any* differentiable function f . This solution is uniform in real space ($\partial\rho/\partial\mathbf{r} \equiv 0$) and shifts to larger and larger momenta $\hbar\mathbf{k}$ for $t \rightarrow \infty$. It thus describes the *free acceleration* of electrons in an electric field. There is no finite conductivity since the current never reaches a stationary value. This is obviously not a correct description of a normal metal. Our mistake has been to ignore scattering.

Scattering will change ρ as a function of time beyond what as already included in Eq. (4.9). We collect all processes not included in Eq. (4.9) into a *scattering term* $\mathcal{S}[\rho]$:

$$\left(\frac{\partial}{\partial t} + \frac{\hbar\mathbf{k}}{m} \cdot \frac{\partial}{\partial \mathbf{r}} + \frac{\mathbf{F}}{\hbar} \cdot \frac{\partial}{\partial \mathbf{k}} \right) \rho = -\mathcal{S}[\rho]. \quad (4.12)$$

This is the famous *Boltzmann equation*. The notation $\mathcal{S}[\rho]$ signifies that the scattering term is a *functional* of ρ . It is generally not simply a function of the local density $\rho(\mathbf{r}, \mathbf{k}, t)$.

While expressions for $\mathcal{S}[\rho]$ can be derived for various types of scattering—interesting and unconventional transport properties in the normal state can be studied in this way—for our purposes it is sufficient to employ the simple but common *relaxation-time approximation*. It is based on the observation that $\rho(\mathbf{r}, \mathbf{k}, t)$ should relax to thermal equilibrium if no force is applied ($\mathbf{F} \equiv 0$). For fermions, the equilibrium distribution is $\rho_0(\mathbf{k}) \propto n_F(\epsilon_{\mathbf{k}})$. This relaxation is ensured by the ansatz

$$\mathcal{S}[\rho] = \frac{\rho(\mathbf{r}, \mathbf{k}, t) - \rho_0(\mathbf{k})}{\tau}. \quad (4.13)$$

Here, τ is the relaxation time, which determines how fast ρ relaxes towards ρ_0 .

If there are different scattering mechanisms that act independently, the scattering integral is just a sum of contributions of these mechanisms,

$$\mathcal{S}[\rho] = \mathcal{S}_1[\rho] + \mathcal{S}_2[\rho] + \dots \quad (4.14)$$

Consequently, if the relaxation-time approximation is valid the relaxation rate $1/\tau$ can be written as

$$\frac{1}{\tau} = \frac{1}{\tau_1} + \frac{1}{\tau_2} + \dots \quad (4.15)$$

This is Matthiessen's rule. There are three main scattering mechanisms:

- Scattering of electrons by disorder: This gives an essentially temperature-independent contribution, which dominates at low temperatures.
- Electron-phonon interaction: This mechanism is strongly temperature-dependent because the available phase space shrinks at low temperatures. One finds a scattering rate

$$\frac{1}{\tau_{\text{e-ph}}} \propto T^3. \quad (4.16)$$

However, this is not the relevant rate for transport calculations. The conductivity is much more strongly affected by scattering that changes the electron momentum $\hbar\mathbf{k}$ by a lot than by processes that change it very little. *Backscattering* across the Fermi sea is most effective.

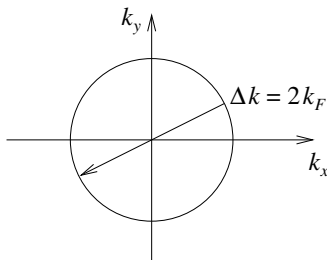

Since backscattering is additionally suppressed at low T , the *transport scattering rate* relevant here scales as

$$\frac{1}{\tau_{\text{e-ph}}^{\text{trans}}} \propto T^5. \quad (4.17)$$

- Electron-electron interaction: For a parabolic free-electron band its contribution to the resistivity is actually zero since Coulomb scattering conserves the total momentum of the two scattering electrons and therefore does not relax the current. However, in a real metal, *umklapp* scattering can take place that conserves the electrons' total momentum only modulo a reciprocal lattice vector. Thus the electron system can transfer momentum to the crystal as a whole and thereby degrade the current. The temperature dependence is typically

$$\frac{1}{\tau_{\text{e-e}}^{\text{umklapp}}} \propto T^2. \quad (4.18)$$

We now consider the force $\mathbf{F} = -e\mathbf{E}$ and calculate the current density

$$\mathbf{j}(\mathbf{r}, t) = -e \int \frac{d^3k}{(2\pi)^3} \underbrace{\frac{\hbar\mathbf{k}}{m}}_{=\mathbf{v}} \rho(\mathbf{r}, \mathbf{k}, t). \quad (4.19)$$

To that end, we solve the Boltzmann equation in the relaxation-time approximation,

$$\left(\frac{\partial}{\partial t} + \frac{\hbar\mathbf{k}}{m} \cdot \frac{\partial}{\partial \mathbf{r}} - \frac{e\mathbf{E}}{\hbar} \cdot \frac{\partial}{\partial \mathbf{k}} \right) \rho = -\frac{\rho - \rho_0}{\tau}. \quad (4.20)$$

We are interested in the *stationary* solution ($\partial\rho/\partial t = 0$), which for a uniform field must be spatially uniform ($\partial\rho/\partial\mathbf{r} = 0$) if it is unique. This gives

$$-\frac{e\mathbf{E}}{\hbar} \cdot \frac{\partial}{\partial \mathbf{k}} \rho(\mathbf{k}) = -\frac{\rho(\mathbf{k}) - \rho_0(\mathbf{k})}{\tau} \quad (4.21)$$

$$\Rightarrow \rho(\mathbf{k}) = \rho_0(\mathbf{k}) + \frac{e\mathbf{E}\tau}{\hbar} \cdot \frac{\partial}{\partial \mathbf{k}} \rho(\mathbf{k}). \quad (4.22)$$

We iterate this equation by inserting it again into the last term:

$$\rho(\mathbf{k}) = \rho_0(\mathbf{k}) + \frac{e\mathbf{E}\tau}{\hbar} \cdot \frac{\partial}{\partial \mathbf{k}} \rho_0(\mathbf{k}) + \left(\frac{e\mathbf{E}\tau}{\hbar} \cdot \frac{\partial}{\partial \mathbf{k}} \right) \frac{e\mathbf{E}\tau}{\hbar} \cdot \frac{\partial}{\partial \mathbf{k}} \rho(\mathbf{k}). \quad (4.23)$$

To make progress, we assume that the applied field \mathbf{E} is small so that the response \mathbf{j} is *linear* in \mathbf{E} . Under this assumption we can truncate the iteration after the linear term,

$$\rho(\mathbf{k}) = \rho_0(\mathbf{k}) + \frac{e\mathbf{E}\tau}{\hbar} \cdot \frac{\partial}{\partial \mathbf{k}} \rho_0(\mathbf{k}). \quad (4.24)$$

By comparing this to the Taylor expansion

$$\rho_0\left(\mathbf{k} + \frac{e\mathbf{E}\tau}{\hbar}\right) = \rho_0(\mathbf{k}) + \frac{e\mathbf{E}\tau}{\hbar} \cdot \frac{\partial}{\partial \mathbf{k}} \rho_0(\mathbf{k}) + \dots \quad (4.25)$$

we see that the solution is, to linear order in \mathbf{E} ,

$$\rho(\mathbf{k}) = \rho_0\left(\mathbf{k} + \frac{e\mathbf{E}\tau}{\hbar}\right) \propto n_F(\epsilon_{\mathbf{k}+e\mathbf{E}\tau/\hbar}). \quad (4.26)$$

Thus the distribution function is simply the Fermi sea shifted in \mathbf{k} -space by $-e\mathbf{E}\tau/\hbar$. Since electrons carry negative charge, the distribution is shifted in the direction *opposite* to the applied electric field.

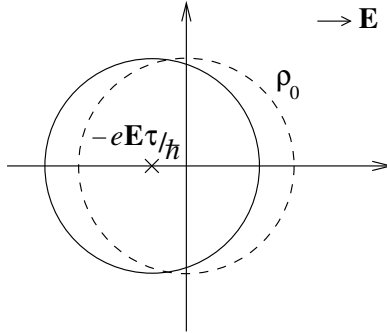

The current density now reads

$$\mathbf{j} = -e \int \frac{d^3k}{(2\pi)^3} \frac{\hbar\mathbf{k}}{m} \rho_0\left(\mathbf{k} + \frac{e\mathbf{E}\tau}{\hbar}\right) \cong \underbrace{-e \int \frac{d^3k}{(2\pi)^3} \frac{\hbar\mathbf{k}}{m} \rho_0(\mathbf{k})}_{=0} - e \int \frac{d^3k}{(2\pi)^3} \frac{\hbar\mathbf{k}}{m} \left(\frac{e\mathbf{E}\tau}{\hbar} \cdot \frac{\partial \rho_0}{\partial \mathbf{k}} \right). \quad (4.27)$$

The first term is the current density in equilibrium, which vanishes. In components, we have

$$j_\alpha = -\frac{e^2\tau}{m} \sum_\beta E_\beta \int \frac{d^3k}{(2\pi)^3} k_\alpha \frac{\partial \rho_0}{\partial k_\beta} \stackrel{\text{by parts}}{=} +\frac{e^2\tau}{m} \sum_\beta E_\beta \int \frac{d^3k}{(2\pi)^3} \underbrace{\frac{\partial k_\alpha}{\partial k_\beta}}_{=\delta_{\alpha\beta}} \rho_0 = \frac{e^2\tau}{m} E_\alpha \int \frac{d^3k}{(2\pi)^3} \rho_0. \quad (4.28)$$

Here, the integral is the concentration of electrons, $n := N/V$. We thus obtain Ohm's law

$$\mathbf{j} = \frac{e^2 n \tau}{m} \mathbf{E} \stackrel{!}{=} \sigma \mathbf{E} \quad (4.29)$$

so that the conductivity is

$$\sigma = \frac{e^2 n \tau}{m}. \quad (4.30)$$

This is the famous *Drude formula*. For the resistivity $\rho = 1/\sigma$ we get, based on our discussion of scattering mechanisms,

$$\rho = \frac{m}{e^2 n \tau} = \frac{m}{e^2 n} \left(\frac{1}{\tau_{\text{dis}}} + \frac{1}{\tau_{\text{e-ph}}^{\text{transport}}} + \frac{1}{\tau_{\text{e-e}}^{\text{umklapp}}} \right). \quad (4.31)$$

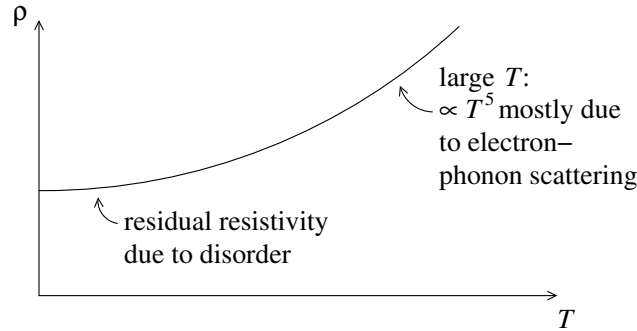

5

Electrodynamics of superconductors

Superconductors are defined by electrodynamic properties—ideal conduction and magnetic-field expulsion. It is thus appropriate to ask how these materials can be described within the formal framework of electrodynamics.

5.1 London theory

In 1935, F. and H. London proposed a phenomenological theory for the electrodynamic properties of superconductors. It is based on a *two-fluid picture*: For unspecified reasons, the electrons form a normal fluid of concentration n_n and a superfluid of concentration n_s , where $n_n + n_s = n = N/V$. Such a picture seemed quite plausible based on Einstein's theory of Bose-Einstein condensation (1925), although nobody understood how the fermionic electrons could form a superfluid. The normal fluid is postulated to behave normally, i.e., to carry an ohmic current

$$\mathbf{j}_n = \sigma_n \mathbf{E} \quad (5.1)$$

governed by the Drude conductivity

$$\sigma_n = \frac{e^2 n_n \tau}{m}. \quad (5.2)$$

The superfluid is assumed to be insensitive to scattering. As noted in section 4.2, this leads to free acceleration of the charges. The Londons have assumed that n_n and n_s are both *uniform* (constant in space) and *stationary* (constant in time). These are serious restrictions of London theory, which will be overcome by Ginzburg-Landau theory. With the supercurrent

$$\mathbf{j}_s = -e n_s \mathbf{v}_s \quad (5.3)$$

and Newton's equation of motion

$$\frac{d}{dt} \mathbf{v}_s = \frac{\mathbf{F}}{m} = -\frac{e\mathbf{E}}{m}, \quad (5.4)$$

we then obtain

$$\frac{\partial \mathbf{j}_s}{\partial t} = \frac{e^2 n_s}{m} \mathbf{E}. \quad (5.5)$$

The same follows from the Boltzmann equation in the absence of scattering. This is the *First London Equation*.

Note that the curl of the First London Equation is

$$\frac{\partial}{\partial t} \nabla \times \mathbf{j}_s = \frac{e^2 n_s}{m} \nabla \times \mathbf{E} \stackrel{\text{Faraday}}{=} -\frac{e^2 n_s}{mc} \frac{\partial \mathbf{B}}{\partial t}. \quad (5.6)$$

This equation can be integrated in time to give

$$\nabla \times \mathbf{j}_s = -\frac{e^2 n_s}{mc} \mathbf{B} + \mathbf{C}(\mathbf{r}), \quad (5.7)$$

where the last term represents a constant of integration at each point \mathbf{r} inside the superconductor. $\mathbf{C}(\mathbf{r})$ should be determined from the initial conditions. If we start from a superconducting body in zero applied magnetic field, we have $\mathbf{j}_s \equiv 0$ and $\mathbf{B} \equiv 0$ initially so that $\mathbf{C}(\mathbf{r}) = 0$. To describe the Meißner-Ochsenfeld effect, we have to consider the case of a body becoming superconducting (by cooling) in a non-zero applied field. However, the outcome cannot be derived within London theory since we have assumed the superfluid density n_s to be constant in time.

To account for the flux expulsion, the Londons *postulated* that $\mathbf{C} \equiv 0$ regardless of the history of the system. This leads to

$$\nabla \times \mathbf{j}_s = -\frac{e^2 n_s}{mc} \mathbf{B}, \quad (5.8)$$

which is the *Second London Equation*.

Taking the curl of Ampère's law

$$\nabla \times \mathbf{B} = \frac{4\pi}{c} \mathbf{j}_s + \frac{4\pi}{c} \mathbf{j}_n \quad (5.9)$$

(there is no displacement current in the stationary state) we get

$$\nabla \times (\nabla \times \mathbf{B}) = -\frac{4\pi e^2 n_s}{mc^2} \mathbf{B} + \frac{4\pi}{c} \sigma_n \nabla \times \mathbf{E} = -\frac{4\pi e^2 n_s}{mc^2} \mathbf{B} - \frac{4\pi}{c} \sigma_n \frac{\partial \mathbf{B}}{\partial t}. \quad (5.10)$$

We drop the last term since we are interested in the stationary state and use an identity from vector calculus (BAC-CAB rule), which gives

$$-\nabla(\nabla \cdot \mathbf{B}) + \nabla^2 \mathbf{B} = \frac{4\pi e^2 n_s}{mc^2} \mathbf{B}. \quad (5.11)$$

Introducing the *London penetration depth*

$$\lambda_L := \sqrt{\frac{mc^2}{4\pi e^2 n_s}}, \quad (5.12)$$

this equation assumes the simple form

$$\nabla^2 \mathbf{B} = \frac{1}{\lambda_L^2} \mathbf{B}. \quad (5.13)$$

Let us consider a semi-infinite superconductor filling the half space $x > 0$. A magnetic field $\mathbf{B}_{\text{apl}} = \mathbf{H}_{\text{apl}} = B_{\text{apl}} \hat{y}$ is applied parallel to the surface. One can immediately see that the equation is solved by

$$\mathbf{B}(x) = B_{\text{apl}} \hat{y} e^{-x/\lambda_L} \quad \text{for } x \geq 0. \quad (5.14)$$

The magnetic field thus decreases exponentially with the distance from the surface of the superconductor. In bulk we indeed find $\mathbf{B} \rightarrow 0$, which is the Meißner-Ochsenfeld effect.

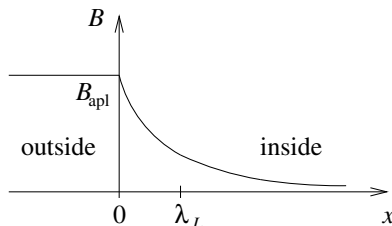

The Second London Equation

$$\nabla \times \mathbf{j}_s = -\frac{c}{4\pi \lambda_L^2} \mathbf{B} \quad (5.15)$$

and the continuity equation

$$\nabla \cdot \mathbf{j}_s = 0 \quad (5.16)$$

can now be solved to give

$$\mathbf{j}_s(x) = -\frac{c}{4\pi \lambda_L} B_{\text{apl}} \hat{z} e^{-x/\lambda_L} \quad \text{for } x \geq 0. \quad (5.17)$$

Thus the supercurrent flows in the direction parallel to the surface and perpendicular to \mathbf{B} and decreases into the bulk on the same scale λ_L . \mathbf{j}_s can be understood as the *screening current* required to keep the magnetic field out of the bulk of the superconductor.

The two London equations (5.5) and (5.8) can be summarized using the vector potential since $\frac{1}{c} \frac{\partial \mathbf{A}}{\partial t} = -\mathbf{E}$ and $\nabla \times \mathbf{A} = \mathbf{B}$:

$$\mathbf{j}_s = -\frac{e^2 n_s}{mc} \mathbf{A}. \quad (5.18)$$

This equation is evidently not gauge invariant since a change of gauge

$$\mathbf{A} \rightarrow \mathbf{A} + \nabla \chi \quad (5.19)$$

changes the supercurrent. (The two London equations are gauge invariant since they are expressed in terms of \mathbf{E} and \mathbf{B} .) Charge conservation requires $\nabla \cdot \mathbf{j}_s = 0$ and thus the vector potential must be transverse,

$$\nabla \cdot \mathbf{A} = 0. \quad (5.20)$$

This is called the *London gauge* in this context and the *Coulomb gauge* in general. Furthermore, the supercurrent through the surface of the superconducting region is proportional to the normal component A_\perp , with constant of proportionality determined by Eq. (5.18). For a simply connected region these conditions uniquely determine $\mathbf{A}(\mathbf{r})$. For a multiply connected region this is not the case; we will return to this point below.

5.2 Rigidity of the superfluid state

F. London has given a quantum-mechanical justification for the London equations. If the many-body wave function of the electrons forming the superfluid is $\Psi_s(\mathbf{r}_1, \mathbf{r}_2, \dots)$ then the supercurrent in the presence of a vector potential \mathbf{A} is

$$\mathbf{j}_s(\mathbf{r}) = -e \frac{1}{2m} \sum_j \int d^3 r_1 d^3 r_2 \dots \delta(\mathbf{r} - \mathbf{r}_j) \left[\Psi_s^* \left(\frac{\hbar}{i} \frac{\partial}{\partial \mathbf{r}_j} + \frac{e}{c} \mathbf{A}(\mathbf{r}_j) \right) \Psi_s + \Psi_s \left(-\frac{\hbar}{i} \frac{\partial}{\partial \mathbf{r}_j} + \frac{e}{c} \mathbf{A}(\mathbf{r}_j) \right) \Psi_s^* \right]. \quad (5.21)$$

Here, j sums over all electrons in the superfluid, which have position \mathbf{r}_j and momentum operator

$$\mathbf{p}_j = \frac{\hbar}{i} \frac{\partial}{\partial \mathbf{r}_j}. \quad (5.22)$$

Splitting the kinetic and electromagnetic terms, we obtain

$$\begin{aligned} \mathbf{j}_s(\mathbf{r}) &= -\frac{e\hbar}{2mi} \sum_j \int d^3 r_1 d^3 r_2 \dots \delta(\mathbf{r} - \mathbf{r}_j) \left[\Psi_s^* \frac{\partial}{\partial \mathbf{r}_j} \Psi_s - \Psi_s \frac{\partial}{\partial \mathbf{r}_j} \Psi_s^* \right] \\ &\quad - \frac{e^2}{mc} \mathbf{A}(\mathbf{r}) \sum_j \int d^3 r_1 d^3 r_2 \dots \delta(\mathbf{r} - \mathbf{r}_j) \Psi_s^* \Psi_s \\ &= -\frac{e\hbar}{2mi} \sum_j \int d^3 r_1 d^3 r_2 \dots \delta(\mathbf{r} - \mathbf{r}_j) \left[\Psi_s^* \frac{\partial}{\partial \mathbf{r}_j} \Psi_s - \Psi_s \frac{\partial}{\partial \mathbf{r}_j} \Psi_s^* \right] - \frac{e^2 n_s}{mc} \mathbf{A}(\mathbf{r}). \end{aligned} \quad (5.23)$$

In general, the wave function Ψ_s depends on \mathbf{A} . Now London proposed that the wave function is *rigid* under the application of a transverse vector potential. More specifically, he suggested that Ψ_s does not contain a term of first order in \mathbf{A} , in the gauge $\nabla \cdot \mathbf{A} = 0$.¹ Then, to first order in \mathbf{A} , the first term on the right-hand side in Eq. (5.23) contains the unperturbed wave function one would obtain for $\mathbf{A} = 0$. The first term is thus the

¹A possible argument for this goes as follows: a linear term would necessarily be proportional to $\mathbf{c} \cdot \mathbf{A}(\mathbf{r})$, where \mathbf{c} is some vector. However, the whole current density and also its first term only depend (implicitly) on a single vector, namely $\mathbf{A}(\mathbf{r})$. Since there is no \mathbf{c} there cannot appear a linear term.

supercurrent for $\mathbf{A} \equiv 0$, which should vanish due to Ampère's law. Consequently, to first order in \mathbf{A} we obtain the London equation

$$\mathbf{j}_s = -\frac{e^2 n_s}{mc} \mathbf{A}. \quad (5.24)$$

The rigidity of Ψ_s was later understood in the framework of BCS theory as resulting from the existence of a non-zero energy gap for excitations out of the superfluid state.

5.3 Flux quantization

We now consider two concentric superconducting cylindrical shells that are thick compared to the London penetration depth λ_L . A magnetic flux

$$\Phi = \int_{\bigcirc} d^2 r B_{\perp} \quad (5.25)$$

penetrates the inner hole and a thin surface layer with a thickness on the order of λ_L of the inner cylinder. The only purpose of the inner cylinder is to prevent the magnetic field from touching the outer cylinder, which we are really interested in. The outer cylinder is completely field free. We want to find the possible values of the flux Φ .

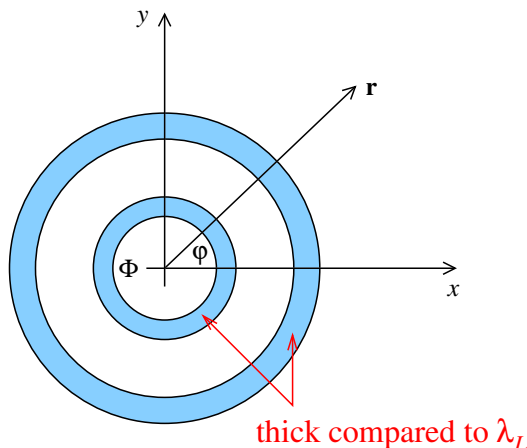

Although the region outside of the inner cylinder has $\mathbf{B} = 0$, the vector potential does not vanish. The relation $\nabla \times \mathbf{A} = \mathbf{B}$ implies

$$\oint ds \cdot \mathbf{A} = \iint d^2 \mathbf{r} \cdot \mathbf{B} = \Phi. \quad (5.26)$$

By symmetry, the tangential part of \mathbf{A} is

$$A_{\varphi} = \frac{\Phi}{2\pi r}. \quad (5.27)$$

The London gauge requires this to be the only non-zero component. Thus outside of the inner cylinder we have, in cylindrical coordinates,

$$\mathbf{A} = \frac{\Phi}{2\pi r} \hat{\varphi}. \quad (5.28)$$

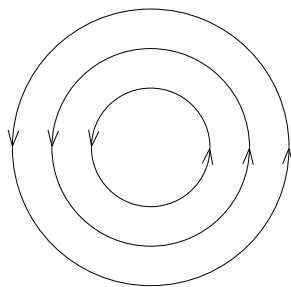

This can be rewritten as

$$\mathbf{A} = \nabla \frac{\Phi \varphi}{2\pi}. \quad (5.29)$$

Since this is a pure gradient, we can get from $\mathbf{A} = 0$ to $\mathbf{A} = (\Phi/2\pi r) \hat{\varphi}$ by a gauge transformation

$$\mathbf{A} \rightarrow \mathbf{A} + \nabla \chi \quad (5.30)$$

with

$$\chi = \frac{\Phi \varphi}{2\pi}. \quad (5.31)$$

χ is continuous but multivalued outside of the inner cylinder. Its gradient is single valued, though. We recall that a gauge transformation of \mathbf{A} must be accompanied by a transformation of the wave function,

$$\Psi_s \rightarrow \exp\left(-\frac{i e}{\hbar c} \sum_j \chi(\mathbf{r}_j)\right) \Psi_s. \quad (5.32)$$

This is most easily seen by noting that it guarantees the current \mathbf{j}_s , Eq. (5.21) in Sec. 5.2, to remain invariant under gauge transformations. Thus the wavefunction at $\Phi = 0$ ($\mathbf{A} = 0$) and at non-zero flux Φ are related by

$$\Psi_s^\Phi = \exp\left(-\frac{i e}{\hbar c} \sum_j \frac{\Phi \varphi_j}{2\pi}\right) \Psi_s^0 = \exp\left(-i \frac{e}{\hbar c} \Phi \sum_j \varphi_j\right) \Psi_s^0, \quad (5.33)$$

where φ_j is the polar angle of electron j . It may seem strange that a gauge transformation connects two states with different observable properties, namely different fluxes. However, this is possible here since the transformation is not done in all of space but only outside of the inner cylinder, which constitutes a region that is not simply connected.

For Ψ_s^Φ as well as Ψ_s^0 to be single valued and continuous, the exponential factor must not change for $\varphi_j \rightarrow \varphi_j + 2\pi$ for any j . This is the case if

$$\frac{e}{\hbar c} \Phi \in \mathbb{Z} \quad \Leftrightarrow \quad \Phi = n \frac{\hbar c}{e} \quad \text{with } n \in \mathbb{Z}. \quad (5.34)$$

We find that the magnetic flux Φ is quantized in units of $\hbar c/e$. Note that the inner cylinder can be omitted: Assume we are heating it enough to become normal-conducting. Then the flux Φ will fill the whole interior of the *outer* cylinder plus a thin (on the order of λ_L) layer on its inside. But if the outer cylinder is much thicker than λ_L , this should not affect Ψ_s appreciably, away from this thin layer.

The quantum $\hbar c/e$ is actually not correct. Based in the idea that *two* electrons could form a boson that could Bose-Einstein condense, Onsager suggested that the relevant charge is $2e$ instead of e , leading to the superconducting flux quantum

$$\Phi_0 := \frac{\hbar c}{2e}, \quad (5.35)$$

which is indeed found in experiments.

5.4 Nonlocal response: Pippard theory

Experiments often find a magnetic penetration depth λ that is significantly larger than the Londons' prediction λ_L , in particular in dirty samples with large scattering rates $1/\tau$ in the normal state. Pippard explained this on the basis of a nonlocal electromagnetic response of the superconductor. The underlying idea is that the quantum state of the electrons forming the superfluid cannot be arbitrarily localized. The typical energy scale of superconductivity is expected to be $k_B T_c$. Only electrons with energies ϵ within $\sim k_B T_c$ of the Fermi energy can contribute appreciably. This corresponds to a momentum range Δp determined by

$$\frac{k_B T_c}{\Delta p} \stackrel{!}{=} \left. \frac{\partial \epsilon}{\partial p} \right|_{\epsilon=E_F} = v_F \quad (5.36)$$

$$\Rightarrow \Delta p = \frac{k_B T_c}{v_F}, \quad (5.37)$$

with the Fermi velocity v_F . From this and Heisenberg's uncertainty principle, we estimate that the electrons cannot be localized on scales smaller than

$$\Delta x \approx \frac{\hbar}{2\Delta p} = \frac{1}{2} \frac{\hbar v_F}{k_B T_c}. \quad (5.38)$$

Therefore, Pippard introduced the *coherence length*

$$\xi_0 = \alpha \frac{\hbar v_F}{k_B T_c} \quad (5.39)$$

as a measure of the minimum extent of electronic wavepackets. α is a numerical constant of order unity. BCS theory predicts $\alpha \approx 0.180$. Pippard proposed to replace the local equation

$$\mathbf{j}_s = -\frac{e^2 n_s}{mc} \mathbf{A} \quad (5.40)$$

of London theory by the nonlocal expression

$$\mathbf{j}_s(\mathbf{r}) = -\frac{3}{4\pi\xi_0} \frac{e^2 n_s}{mc} \int d^3 r' \frac{\Delta \mathbf{r} (\Delta \mathbf{r} \cdot \mathbf{A}(\mathbf{r}'))}{(\Delta r)^4} e^{-\Delta r/\xi_0} \quad (5.41)$$

with

$$\Delta \mathbf{r} = \mathbf{r} - \mathbf{r}'. \quad (5.42)$$

The special form of this equation was motivated by an earlier nonlocal generalization of Ohm's law. The main point is that electrons within a distance ξ_0 of the point \mathbf{r}' where the field \mathbf{A} acts have to respond to it because of the minimum localization of the electronic state. If \mathbf{A} *does not* change appreciably on the scale of ξ_0 , we obtain

$$\mathbf{j}_s(\mathbf{r}) \cong -\frac{3}{4\pi\xi_0} \frac{e^2 n_s}{mc} \int d^3 r' \frac{\Delta \mathbf{r} (\Delta \mathbf{r} \cdot \mathbf{A}(\mathbf{r}))}{(\Delta r)^4} e^{-\Delta r/\xi_0} = -\frac{3}{4\pi\xi_0} \frac{e^2 n_s}{mc} \int d^3 \Delta r \frac{\Delta \mathbf{r} (\Delta \mathbf{r} \cdot \mathbf{A}(\mathbf{r}))}{(\Delta r)^4} e^{-\Delta r/\xi_0}. \quad (5.43)$$

The result has to be parallel to $\mathbf{A}(\mathbf{r})$ by symmetry (since it is a vector depending on a single vector $\mathbf{A}(\mathbf{r})$). Thus

$$\begin{aligned} \mathbf{j}_s(\mathbf{r}) &= -\frac{3}{4\pi\xi_0} \frac{e^2 n_s}{mc} \mathbf{A}(\mathbf{r}) \int d^3 \Delta r \frac{(\Delta \mathbf{r} \cdot \hat{\mathbf{A}}(\mathbf{r}))^2}{(\Delta r)^4} e^{-\Delta r/\xi_0} \\ &= -\frac{3}{4\pi\xi_0} \frac{e^2 n_s}{mc} \mathbf{A}(\mathbf{r}) 2\pi \int_{-1}^1 d(\cos\theta) \int_0^\infty d\Delta r \frac{(\Delta r)^2 \cos^2\theta}{(\Delta r)^4} e^{-\Delta r/\xi_0} \\ &= -\frac{3}{4\pi\xi_0} \frac{e^2 n_s}{mc} \mathbf{A}(\mathbf{r}) 2\pi \frac{2}{3} \xi_0 = -\frac{e^2 n_s}{mc} \mathbf{A}(\mathbf{r}). \end{aligned} \quad (5.44)$$

We recover the local London equation. However, for many conventional superconductors, ξ_0 is much larger than λ . Then $\mathbf{A}(\mathbf{r})$ drops to zero on a length scale of $\lambda \ll \xi_0$. According to Pippard's equation, the electrons respond to the vector potential averaged over regions of size ξ_0 . This averaged field is much smaller than \mathbf{A} at the surface so that the screening current \mathbf{j}_s is strongly reduced and the magnetic field penetrates much deeper than predicted by London theory, i.e., $\lambda \gg \lambda_L$.

To be a bit more quantitative, we can estimate the averaged vector potential and thus the screening current to be reduced by a factor on the order of λ/ξ_0 . From Ampère's law $\nabla \times \mathbf{B} = \frac{4\pi}{c} \mathbf{j}_s$, we infer that the length scale of the exponential decay of \mathbf{B} , i.e., the effective penetration depth, should then be enhanced by the inverse of this factor. We thus get

$$\lambda \approx \lambda_L \frac{\xi_0}{\lambda} \quad (5.45)$$

$$\Rightarrow \lambda^2 \approx \lambda_L \xi_0 \quad (5.46)$$

$$\Rightarrow \lambda \approx \sqrt{\lambda_L \xi_0}, \quad (5.47)$$

i.e., we estimate the effective penetration depth to be the geometric mean of the London penetration depth and Pippard's coherence length. Note that for $\lambda_L \ll \xi_0$ we obtain $\lambda_L \ll \lambda \ll \xi_0$, consistent with our arguments. Remember that the result $\lambda \approx \sqrt{\lambda_L \xi_0}$ only holds in this limit.

The above motivation for the coherence length ξ_0 relied on having a clean system. In the presence of strong scattering the electrons can be localized on the scale of the mean free path $l := v_F \tau$. Pippard phenomenologically generalized the equation for \mathbf{j}_s by introducing a new length ξ where

$$\frac{1}{\xi} = \frac{1}{\xi_0} + \frac{1}{\beta l} \quad (5.48)$$

(β is a numerical constant of order unity) and writing

$$\mathbf{j}_s = -\frac{3}{4\pi\xi_0} \frac{e^2 n_s}{mc} \int d^3 r' \frac{\Delta \mathbf{r} (\Delta \mathbf{r} \cdot \mathbf{A}(\mathbf{r}'))}{(\Delta r)^4} e^{-\Delta r/\xi}. \quad (5.49)$$

Note that ξ_0 appears in the prefactor but ξ in the exponential. This expression is in good agreement with experiments for series of samples with varying disorder. It is essentially the same as the result of BCS theory. Also note that in the *dirty limit* $l \ll \xi_0, \lambda_L$ we again recover the *local* London result following the same argument as above, but since the integral gives a factor of ξ , which is not canceled by the prefactor $1/\xi_0$, the current is reduced to

$$\mathbf{j}_s = -\frac{e^2 n_s}{mc} \frac{\xi}{\xi_0} \mathbf{A} \cong -\frac{e^2 n_s}{mc} \frac{\beta l}{\xi_0} \mathbf{A}. \quad (5.50)$$

Note that the small mean free path in the dirty limit makes the response local again.

Taking the curl, we obtain

$$\nabla \times \mathbf{j}_s = -\frac{e^2 n_s}{mc} \frac{\beta l}{\xi_0} \mathbf{B} \quad (5.51)$$

$$\Rightarrow \nabla \times \nabla \times \mathbf{B} = -\frac{4\pi e^2 n_s}{mc^2} \frac{\beta l}{\xi_0} \mathbf{B} \quad (5.52)$$

$$\Rightarrow \nabla^2 \mathbf{B} = \frac{4\pi e^2 n_s}{mc^2} \frac{\beta l}{\xi_0} \mathbf{B}, \quad (5.53)$$

in analogy to the derivation in Sec. 5.1. This equation is of the form

$$\nabla^2 \mathbf{B} = \frac{1}{(\lambda_L^{\text{dis}})^2} \mathbf{B} \quad (5.54)$$

with the London penetration depth

$$\lambda_L^{\text{dis}} = \sqrt{\frac{mc^2}{4\pi e^2 n_s}} \sqrt{\frac{\xi_0}{\beta l}} = \lambda_L \sqrt{\frac{\xi_0}{\beta l}}. \quad (5.55)$$

Thus the penetration depth is increased by a factor of order $\sqrt{\xi_0/l}$ in the dirty limit, $l \ll \xi_0, \lambda_L$. Since the response is local in the dirty limit, the effective penetration depth equals the modified London result, i.e.,

$$\lambda_{\text{dis}} = \lambda_L \sqrt{\frac{\xi_0}{\beta l}}. \quad (5.56)$$

6

Ginzburg-Landau theory

Within London and Pippard theory, the superfluid density n_s is treated as given. There is no way to understand the dependence of n_s on, for example, temperature or applied magnetic field within these theories. Moreover, n_s has been assumed to be constant in time and uniform in space—an assumption that is expected to fail close to the surface of a superconductor.

These deficiencies are cured by the Ginzburg-Landau theory put forward in 1950. Like Ginzburg and Landau we ignore complications due to the nonlocal electromagnetic response. Ginzburg-Landau theory is developed as a generalization of London theory, not of Pippard theory (which was in fact presented after Ginzburg-Landau theory). The starting point is the much more general and very powerful Landau theory of phase transitions, which we will review first.

6.1 Landau theory of phase transitions

Landau introduced the concept of the *order parameter* to describe phase transitions. In this context, an order parameter is a thermodynamic variable that is zero on one side of the transition and nonzero on the other. In ferromagnets, the magnetization \mathbf{M} is the order parameter. The theory neglects fluctuations, which means that the order parameter is assumed to be constant in time and space (Ginzburg-Landau theory will go beyond this). Landau theory is thus a *mean-field theory*. Now the appropriate thermodynamic potential can be written as a function of the order parameter, which we call Δ , and certain other thermodynamic quantities such as pressure or volume, magnetic field, etc. We will always call the potential the *free energy* F , but whether it really is a free energy, a free enthalpy, or something else depends on which quantities are given (pressure vs. volume etc.). Hence, we write

$$F = F(\Delta, T), \tag{6.1}$$

where T is the temperature, and further variables have been suppressed. The equilibrium state at temperature T is the one that minimizes the free energy. Generally, we do not know $F(\Delta, T)$ explicitly. Landau's idea was to expand F in terms of Δ , including only those terms that are allowed by the symmetry of the system and keeping the minimum number of the simplest terms required to get nontrivial results.

For example, in an isotropic ferromagnet, the order parameter is the three-component vector \mathbf{M} . The free energy must be invariant under rotations of \mathbf{M} because of isotropy. Furthermore, as usual in physics, we assume F to be a smooth, i.e., differentiable, function of \mathbf{M} . Then the leading terms, apart from a trivial constant, are

$$F \cong \alpha \mathbf{M} \cdot \mathbf{M} + \frac{\beta}{2} (\mathbf{M} \cdot \mathbf{M})^2 + \mathcal{O}((\mathbf{M} \cdot \mathbf{M})^3). \tag{6.2}$$

Denoting the coefficients by α and $\beta/2$ is just convention. α and β are functions of temperature (and pressure etc.).

What is the corresponding expansion for a superfluid or superconductor? Lacking a microscopic theory, Ginzburg and Landau assumed based on the analogy with Bose-Einstein condensation that the superfluid part is

described by a single one-particle wave function $\Psi_s(\mathbf{r})$. They imposed the plausible normalization

$$\int d^3r |\Psi_s(\mathbf{r})|^2 = N_s = n_s V; \quad (6.3)$$

N_s is the total number of particles in the condensate. They then chose the complex amplitude ψ of $\Psi_s(\mathbf{r})$ as the order parameter, with the normalization

$$|\psi|^2 \propto n_s. \quad (6.4)$$

Thus the order parameter in this case is a complex number. They thereby neglected the spatial variation of $\Psi_s(\mathbf{r})$ on an atomic scale.

The free energy must not depend on the global phase of $\Psi_s(\mathbf{r})$ because the global phase of quantum states is not observable. Thus we obtain the expansion

$$F = \alpha |\psi|^2 + \frac{\beta}{2} |\psi|^4 + \mathcal{O}(|\psi|^6). \quad (6.5)$$

Odd powers are excluded since they are not differentiable at $\psi = 0$. If $\beta > 0$, which is not guaranteed by symmetry but is true for superconductors and superfluids, we can neglect higher-order terms since $\beta > 0$ then makes sure that $F(\psi)$ is bounded from below. Now there are two cases:

- If $\alpha \geq 0$, $F(\psi)$ has a single minimum at $\psi = 0$. Thus the equilibrium state has $n_s = 0$. This is clearly a normal fluid or normal metal ($n_n = n$).
- If $\alpha < 0$, $F(\psi)$ has a ring of minima with equal amplitude (modulus) $|\psi|$ but arbitrary phase. We easily see

$$\frac{\partial F}{\partial |\psi|} = 2\alpha |\psi| + 2\beta |\psi|^3 = 0 \quad \Rightarrow \quad |\psi| = 0 \text{ (this is a maximum) or } |\psi| = \sqrt{-\frac{\alpha}{\beta}} \quad (6.6)$$

Note that the radicand is positive.

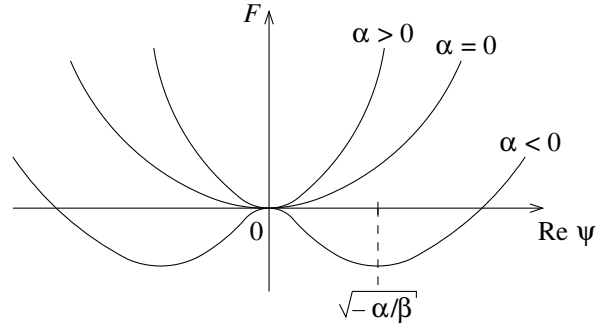

$F(\psi)$ for $\alpha < 0$ is often called the Mexican-hat or wine-bottle potential (imagine this figure rotated around the vertical axis to find F as a function of the complex ψ). In Landau theory, the phase transition clearly occurs when $\alpha = 0$. Since then $T = T_c$ by definition it is useful to expand α and β to leading order in T around T_c . Hence,

$$\alpha \cong \alpha'(T - T_c), \quad \alpha' > 0, \quad (6.7)$$

$$\beta \cong \text{const.} \quad (6.8)$$

Then the order parameter below T_c satisfies

$$|\psi| \cong \sqrt{-\frac{\alpha'(T - T_c)}{\beta}} = \sqrt{\frac{\alpha'}{\beta}} \sqrt{T_c - T}. \quad (6.9)$$

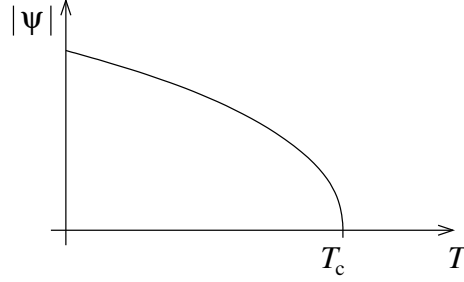

The scaling $|\psi| \propto (T - T_c)^{1/2}$ is characteristic for mean-field theories.

All solutions with this value of $|\psi|$ minimize the free energy. In a given experiment, only one of them is realized. This equilibrium state has an order parameter $\psi = |\psi| e^{i\phi}$ with some fixed phase ϕ . This state is clearly not invariant under rotations of the phase. We say that the *global* U(1) *symmetry* of the system is spontaneously broken since the free energy F has it but the particular equilibrium state does not. It is called U(1) symmetry since the group U(1) of unitary 1×1 matrices just contains phase factors $e^{i\phi}$.

Note that the expansion of F up to fourth order is only justified as long as ψ is small. Its quantitative validity is thus limited to temperatures not too far below T_c . However, one can often gain insight into the qualitative behavior of a system by applying Landau theory outside of this range.

Specific heat

Since we now know the mean-field free energy as a function of temperature we can calculate further thermodynamic variables. In particular, the entropy is

$$S = -\frac{\partial F}{\partial T}. \quad (6.10)$$

Since the expression for F used above only includes the contributions of superconductivity or superfluidity the entropy calculated from it will also only contain these contributions. For $T \geq T_c$, the mean-field free energy is $F(\psi = 0) = 0$ and thus we find $S = 0$. For $T < T_c$ we instead obtain

$$\begin{aligned} S &= -\frac{\partial}{\partial T} F \left(\sqrt{-\frac{\alpha}{\beta}} \right) = -\frac{\partial}{\partial T} \left(-\frac{\alpha^2}{\beta} + \frac{1}{2} \frac{\alpha^2}{\beta} \right) = \frac{\partial}{\partial T} \frac{\alpha^2}{2\beta} \\ &\cong \frac{\partial}{\partial T} \frac{(\alpha')^2}{2\beta} (T - T_c)^2 = \frac{(\alpha')^2}{\beta} (T - T_c) = -\frac{(\alpha')^2}{\beta} (T_c - T) < 0. \end{aligned} \quad (6.11)$$

We find that the entropy is continuous at $T = T_c$. By definition, this means that the phase transition is *continuous*, i.e., not of first order.

The corresponding heat capacity of the superconductor or superfluid is

$$C = T \frac{\partial S}{\partial T}, \quad (6.12)$$

which equals zero for $T \geq T_c$ but is

$$C = \frac{(\alpha')^2}{\beta} T \quad (6.13)$$

for $T < T_c$. Thus, the heat capacity has a *jump discontinuity* of

$$\Delta C = -\frac{(\alpha')^2}{\beta} T_c \quad (6.14)$$

at T_c . The phase transition is of *second* order since a *second* derivative of a thermodynamic potential (F) with respect to its natural variables (T) is the lowest discontinuous one. Adding the other contributions, which are analytic at T_c , the specific heat $c := C/V$ is sketched here:

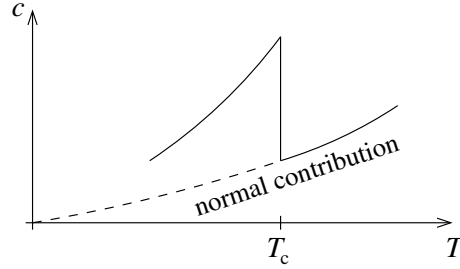

The enhanced specific heat can be understood as being due to the “soft” phase fluctuations in the wine-bottle potential. Recall that Landau theory only works close to T_c . In particular, for the specific heat it does not give reasonable results for $T \ll T_c$.

6.2 Ginzburg-Landau theory for neutral superfluids

To be able to describe spatially nonuniform situations, Ginzburg and Landau had to go beyond the Landau description for a constant order parameter. To do so, they included *gradients*. We will first discuss the simpler case of a superfluid of electrically neutral particles (think of He-4). We define a macroscopic condensate wave function $\psi(\mathbf{r})$, which is essentially given by $\Psi_s(\mathbf{r})$ averaged over length scales large compared to atomic distances. We expect any spatial changes of $\psi(\mathbf{r})$ to cost energy—this is analogous to the energy of domain walls in magnetic systems. In the spirit of Landau theory, Ginzburg and Landau included the simplest term containing gradients of ψ and allowed by symmetry into the free energy

$$F[\psi] = \int d^3r \left[\alpha |\psi|^2 + \frac{\beta}{2} |\psi|^4 + \gamma (\nabla\psi)^* \cdot \nabla\psi \right], \quad (6.15)$$

where we have changed the definitions of α and β slightly. We require $\gamma > 0$ so that the system does not spontaneously become highly nonuniform. The above expression is a *functional* of ψ , also called the *Landau or Ginzburg-Landau functional*. Calling it a “free energy” is really an abuse of language since the free energy proper is only the value assumed by $F[\psi]$ at its minimum.

If we interpret $\psi(\mathbf{r})$ as the (coarse-grained) condensate wave function it is natural to identify the gradient term as a kinetic energy by writing

$$F[\psi] = \int d^3r \left[\alpha |\psi|^2 + \frac{\beta}{2} |\psi|^4 + \frac{1}{2m^*} \left| \frac{\hbar}{i} \nabla\psi \right|^2 \right], \quad (6.16)$$

where m^* is an effective mass of the particles forming the condensate. Evidently, the two expressions for $F[\psi]$ are related by $\gamma = \hbar^2/2m^*$.

From $F[\psi]$, we can derive a differential equation for the function $\psi(\mathbf{r})$ that minimizes F . The derivation is very similar to the derivation of the Lagrange equation (of the second kind) from Hamilton’s principle $\delta S = 0$ known from classical mechanics. Here, we start from the extremum principle $\delta F = 0$. We write

$$\psi(\mathbf{r}) = \psi_0(\mathbf{r}) + \eta(\mathbf{r}), \quad (6.17)$$

where $\psi_0(\mathbf{r})$ is the as yet unknown solution and $\eta(\mathbf{r})$ is a small deviation from it. Then

$$\begin{aligned} F[\psi_0 + \eta] &= F[\psi_0] \\ &+ \int d^3r \left[\alpha\psi_0^*\eta + \alpha\eta^*\psi_0 + \beta\psi_0^*\psi_0\eta + \beta\psi_0^*\eta^*\psi_0\psi_0 + \frac{\hbar^2}{2m^*}(\nabla\psi_0)^* \cdot \nabla\eta + \frac{\hbar^2}{2m^*}(\nabla\eta)^* \cdot \nabla\psi_0 \right] \\ &+ \mathcal{O}(\eta, \eta^*)^2 \\ &\stackrel{\text{by parts}}{=} F[\psi_0] \end{aligned}$$

$$\begin{aligned}
& + \int d^3r \left[\alpha \psi_0^* \eta + \alpha \eta^* \psi_0 + \beta \psi_0^* \psi_0^* \psi_0 \eta + \beta \psi_0^* \eta^* \psi_0 \psi_0 - \frac{\hbar^2}{2m^*} (\nabla^2 \psi_0)^* \eta - \frac{\hbar^2}{2m^*} \eta^* \nabla^2 \psi_0 \right] \\
& + \mathcal{O}(\eta, \eta^*)^2.
\end{aligned} \tag{6.18}$$

If $\psi_0(\mathbf{r})$ is to minimize F the terms linear in η and η^* must vanish for any $\eta(\mathbf{r}), \eta^*(\mathbf{r})$. Noting that η and η^* are linearly independent, this requires the prefactors of η and η^* to vanish for all \mathbf{r} . Thus we conclude that

$$\alpha \psi_0 + \beta \underbrace{\psi_0^* \psi_0}_{=|\psi_0|^2} \psi_0 - \frac{\hbar^2}{2m^*} \nabla^2 \psi_0 = 0. \tag{6.19}$$

Dropping the subscript “0” and rearranging terms we find

$$-\frac{\hbar^2}{2m^*} \nabla^2 \psi + \alpha \psi + \beta |\psi|^2 \psi = 0. \tag{6.20}$$

This equation is very similar to the time-independent Schrödinger equation but, interestingly, it contains a nonlinear term. It is also called the (time-independent) Gross-Pitaevskii equation, in particular when derived from a microscopic description of an interacting superfluid.

We now apply this equation to find the variation of $\psi(\mathbf{r})$ close to the surface of a superfluid filling the half space $x > 0$. We impose the boundary condition $\psi(x=0) = 0$ and assume that the solution only depends on x . Then

$$-\frac{\hbar^2}{2m^*} \psi''(x) + \alpha \psi(x) + \beta |\psi(x)|^2 \psi(x) = 0. \tag{6.21}$$

Since all coefficients are real the solution can be chosen real. For $x \rightarrow \infty$ we should obtain the uniform solution

$$\lim_{x \rightarrow \infty} \psi(x) = \sqrt{-\frac{\alpha}{\beta}}. \tag{6.22}$$

Writing

$$\psi(x) = \sqrt{-\frac{\alpha}{\beta}} f(x), \tag{6.23}$$

we obtain

$$-\frac{\hbar^2}{\underbrace{2m^* \alpha}_{>0}} f''(x) + f(x) - f(x)^3 = 0. \tag{6.24}$$

This equation contains a characteristic length scale $\xi > 0$ with

$$\xi^2 := -\frac{\hbar^2}{2m^* \alpha} \cong \frac{\hbar^2}{2m^* \alpha' (T_c - T)} > 0, \tag{6.25}$$

which is called the *Ginzburg-Landau coherence length*. It is not the same quantity as the Pippard coherence length ξ_0 , which is often also denoted by ξ . The Ginzburg-Landau ξ has a strong temperature dependence and actually diverges at $T = T_c$, whereas the Pippard ξ has at most a weak temperature dependence. Microscopic BCS theory reveals how the two quantities are related.

Equation (6.24) can be solved analytically. It is easy to check that

$$f(x) = \tanh \frac{x}{\sqrt{2} \xi} \tag{6.26}$$

is a solution satisfying the boundary conditions at $x = 0$ and $x \rightarrow \infty$. (In the general, three-dimensional case, the solution can only be given in terms of Jacobian elliptic functions.) The one-dimensional tanh solution is sketched here:

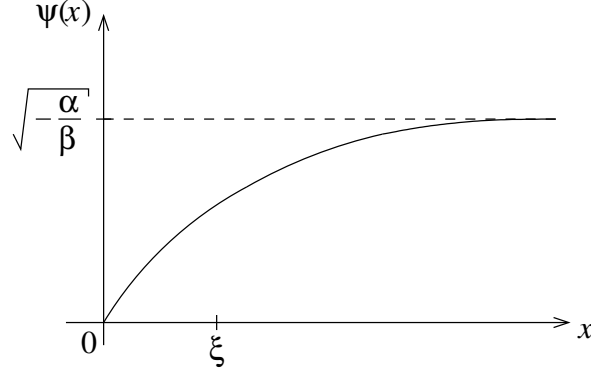

Fluctuations for $T > T_c$

So far, we have only considered the state ψ_0 of the system that minimizes the Landau functional $F[\psi]$. This is the *mean-field state*. At nonzero temperatures, the system will fluctuate about ψ_0 . For a uniform system we have

$$\psi(\mathbf{r}) = \psi_0 + \delta\psi(\mathbf{r}), \quad (6.27)$$

with $\psi_0 = \text{const.}$ We consider the cases $T > T_c$ and $T < T_c$ separately.

For $T > T_c$, the mean-field solution is just $\psi_0 = 0$ so that $\psi(\mathbf{r}) = \delta\psi(\mathbf{r})$. We now write the partition function \mathcal{Z} as a sum of Boltzmann factors containing the Landau functional of all possible states,

$$\mathcal{Z} = \int D^2\psi e^{-F[\psi]/k_B T}. \quad (6.28)$$

This equation requires some discussion. We are obviously using $F[\psi]$ as if it were the Hamiltonian of the field $\psi(\mathbf{r}, t)$, while we have introduced it as a generalization of a Landau “free energy.” This apparent inconsistency is resolved by recalling that $\psi(\mathbf{r}, t)$ is the macroscopic condensate wave function. We have said above that $\psi(\mathbf{r}, t)$ is averaged over length scales large compared to atomic distances. More precisely, fluctuations of the wave function on shorter length scales have been integrated out (in a renormalization-group sense) so that $F[\psi]$ can indeed be understood as a free energy with respect to these small-scale fluctuations but it is the energy for the longer-scale fluctuations we are considering here. This has been explained nicely by Ma in his book “Modern Theory of Critical Phenomena” (Benjamin, Reading, 1976).

The notation $D^2\psi$ in Eq. (6.28) expresses that the integral is over infinitely many complex variables, namely the values of $\psi(\mathbf{r})$ for all \mathbf{r} . This means that \mathcal{Z} is technically a functional integral. The mathematical details go beyond the scope of this course but are not essential for understanding the physics. The integral is difficult to evaluate. A common approximation is to restrict $F[\psi]$ to second-order terms, which is reasonable for $T > T_c$ since the fourth-order term $(\beta/2) |\psi|^4$ is not required to stabilize the theory (i.e., to make $F \rightarrow \infty$ for $|\psi| \rightarrow \infty$). This is called the *Gaussian approximation*. It allows \mathcal{Z} to be evaluated by Fourier transformation: We start from

$$F[\psi] \cong \int d^3r \left[\alpha \psi^*(\mathbf{r}) \psi(\mathbf{r}) + \frac{1}{2m^*} \left(\frac{\hbar}{i} \nabla \psi(\mathbf{r}) \right)^* \cdot \frac{\hbar}{i} \nabla \psi(\mathbf{r}) \right] \quad (6.29)$$

and insert

$$\psi(\mathbf{r}) = \frac{1}{\sqrt{V}} \sum_{\mathbf{k}} e^{i\mathbf{k}\cdot\mathbf{r}} \psi_{\mathbf{k}}, \quad (6.30)$$

which gives

$$\begin{aligned} F[\psi] &\cong \frac{1}{V} \sum_{\mathbf{k}\mathbf{k}'} \underbrace{\int d^3r e^{-i\mathbf{k}\cdot\mathbf{r}+i\mathbf{k}'\cdot\mathbf{r}}}_{V\delta_{\mathbf{k}\mathbf{k}'}} \left[\alpha \psi_{\mathbf{k}}^* \psi_{\mathbf{k}'} + \frac{1}{2m^*} (\hbar\mathbf{k}\psi_{\mathbf{k}})^* \cdot \hbar\mathbf{k}'\psi_{\mathbf{k}'} \right] \\ &= \sum_{\mathbf{k}} \left(\alpha \psi_{\mathbf{k}}^* \psi_{\mathbf{k}} + \frac{\hbar^2 k^2}{2m^*} \psi_{\mathbf{k}}^* \psi_{\mathbf{k}} \right) \end{aligned}$$

$$= \sum_{\mathbf{k}} \left(\alpha + \frac{\hbar^2 k^2}{2m^*} \right) \psi_{\mathbf{k}}^* \psi_{\mathbf{k}}. \quad (6.31)$$

Thus

$$\begin{aligned} \mathcal{Z} &\cong \int \left(\prod_{\mathbf{k}} d^2 \psi_{\mathbf{k}} \right) \exp \left(-\frac{1}{k_B T} \sum_{\mathbf{k}} \left(\alpha + \frac{\hbar^2 k^2}{2m^*} \right) \psi_{\mathbf{k}}^* \psi_{\mathbf{k}} \right) \\ &= \prod_{\mathbf{k}} \left\{ \int_{\mathcal{C}} d^2 \psi_{\mathbf{k}} \exp \left(-\frac{1}{k_B T} \left(\alpha + \frac{\hbar^2 k^2}{2m^*} \right) \psi_{\mathbf{k}}^* \psi_{\mathbf{k}} \right) \right\} \\ &= \prod_{\mathbf{k}} \left\{ \int_{\mathcal{C}} d^2 \psi \exp \left(-\frac{1}{k_B T} \left(\alpha + \frac{\hbar^2 k^2}{2m^*} \right) \psi^* \psi \right) \right\}. \end{aligned} \quad (6.32)$$

The integral is now of Gaussian type (hence ‘‘Gaussian approximation’’) and can be evaluated exactly:

$$\mathcal{Z} \cong \prod_{\mathbf{k}} \frac{\pi k_B T}{\alpha + \frac{\hbar^2 k^2}{2m^*}}. \quad (6.33)$$

From this, we can obtain the thermodynamic quantities. For example, the heat capacity is

$$\begin{aligned} C &= T \frac{\partial S}{\partial T} = -T \frac{\partial^2 F}{\partial T^2} = T \frac{\partial^2}{\partial T^2} k_B T \ln \mathcal{Z} \\ &\cong k_B T \frac{\partial^2}{\partial T^2} T \sum_{\mathbf{k}} \ln \frac{\pi k_B T}{\alpha + \frac{\hbar^2 k^2}{2m^*}}. \end{aligned} \quad (6.34)$$

We only consider the term that is singular at T_c . It stems from the temperature dependence of $\alpha \cong \alpha'(T - T_c)$, not from the explicit factors of T . This term is

$$\begin{aligned} C_{\text{crit}} &\cong -k_B T^2 \frac{\partial^2}{\partial T^2} \sum_{\mathbf{k}} \ln \left(\alpha + \frac{\hbar^2 k^2}{2m^*} \right) \\ &= -k_B T^2 \frac{\partial}{\partial T} \sum_{\mathbf{k}} \frac{\alpha'}{\alpha + \frac{\hbar^2 k^2}{2m^*}} \\ &= k_B T^2 \sum_{\mathbf{k}} \frac{(\alpha')^2}{\left(\alpha + \frac{\hbar^2 k^2}{2m^*} \right)^2} \\ &= k_B T^2 \left(\frac{2m^*}{\hbar^2} \right)^2 (\alpha')^2 \sum_{\mathbf{k}} \frac{1}{\left(k^2 + \frac{2m^* \alpha}{\hbar^2} \right)^2}. \end{aligned} \quad (6.35)$$

Going over to an integral over \mathbf{k} , corresponding to the thermodynamic limit $V \rightarrow \infty$, we obtain

$$\begin{aligned} C_{\text{crit}} &\cong k_B T^2 \left(\frac{2m^*}{\hbar^2} \right)^2 (\alpha')^2 V \int \frac{d^3 k}{(2\pi)^3} \frac{1}{\left(k^2 + \frac{2m^* \alpha}{\hbar^2} \right)^2} \\ &= \frac{k_B T^2}{2\pi} \frac{(m^*)^2}{\hbar^4} (\alpha')^2 V \frac{1}{\sqrt{\frac{2m^* \alpha}{\hbar^2}}} \\ &= \frac{k_B T^2}{2\sqrt{2}\pi} \frac{(m^*)^{3/2}}{\hbar^3} (\alpha')^2 V \frac{1}{\sqrt{\alpha}} \\ &\propto \frac{1}{\sqrt{T - T_c}}. \end{aligned} \quad (6.36)$$

The exponent $-1/2$ of the specific heat is characteristic for Gaussian fluctuations.¹ Recall that at the mean-field level, C just showed a step at T_c . Including fluctuations, we obtain a divergence of the form $1/\sqrt{T - T_c}$ for $T \rightarrow T_c$

¹Note that the proportionality to $(2m^* \alpha / \hbar^2)^{-1/2} \propto 1/\sqrt{\alpha}$ already follows from dimensional analysis for the momentum integral.

from above. This is due to superfluid fluctuations in the normal state. The system “notices” that superfluid states exist at relatively low energies, while the mean-field state is still normal.

We note for later that the derivation has shown that for any \mathbf{k} we have two fluctuation modes with dispersion

$$\epsilon_{\mathbf{k}} = \alpha + \frac{\hbar^2 k^2}{2m^*}. \quad (6.37)$$

The two modes correspond for example to the real and imaginary parts of $\psi_{\mathbf{k}}$. Since $\alpha = \alpha'(T - T_c) > 0$ the dispersion has an *energy gap* α .

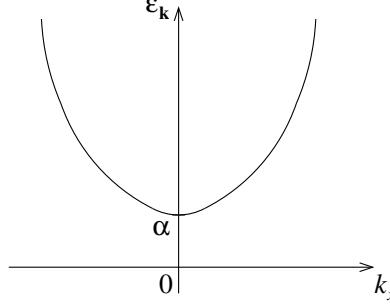

In the language of field theory, one also says that the superfluid above T_c has two degenerate *massive* modes, with the mass proportional to the energy gap.

Fluctuations for $T < T_c$

Below T_c , the situation is a bit more complex due to the wine-bottle potential: All states with amplitude $|\psi_0| = \sqrt{-\alpha/\beta}$ are equally good mean-field solutions.

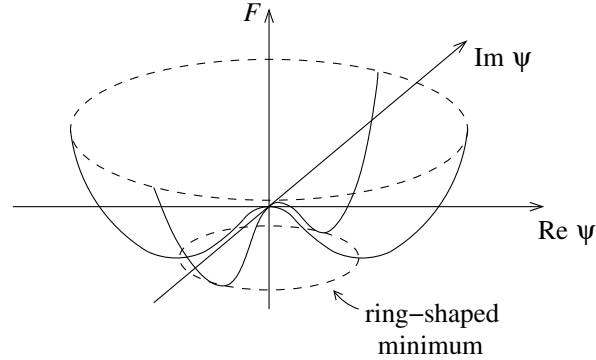

It is plausible that fluctuations of the phase have low energies since *global* changes of the phase do not increase F . To see this, we write

$$\psi = (\psi_0 + \delta\psi) e^{i\phi}, \quad (6.38)$$

where ψ_0 and $\delta\psi$ are now real. The Landau functional becomes

$$F[\psi] \cong \int d^3r \left[\alpha(\psi_0 + \delta\psi)^2 + \frac{\beta}{2}(\psi_0 + \delta\psi)^4 + \frac{1}{2m^*} \left(\frac{\hbar}{i}(\nabla\delta\psi)e^{i\phi} + \hbar(\psi_0 + \delta\psi)(\nabla\phi)e^{i\phi} \right)^* \cdot \left(\frac{\hbar}{i}(\nabla\delta\psi)e^{i\phi} + \hbar(\psi_0 + \delta\psi)(\nabla\phi)e^{i\phi} \right) \right]. \quad (6.39)$$

As above, we keep only terms up to second order in the fluctuations (Gaussian approximation), i.e., terms proportional to $\delta\psi^2$, $\delta\psi\phi$, or ϕ^2 . We get

$$F[\delta\psi, \phi] \cong \int d^3r \left[2\alpha\psi_0\delta\psi + 2\beta\psi_0^3\delta\psi + \alpha\delta\psi^2 + 3\beta\psi_0^3\delta\psi^2 + \frac{1}{2m^*} \left(\frac{\hbar}{i}\nabla\delta\psi \right)^* \cdot \frac{\hbar}{i}\nabla\delta\psi \right]$$

$$+ \frac{1}{2m^*} \left(\underbrace{\left(\frac{\hbar}{i} \nabla \delta\psi \right)^* \cdot \hbar\psi_0 \nabla\phi + (\hbar\psi_0 \nabla\phi)^* \cdot \frac{\hbar}{i} \nabla\delta\psi}_{=0} \right) + \frac{1}{2m^*} (\hbar\psi_0 \nabla\phi)^* \cdot \hbar\psi_0 \nabla\phi \Big] (+ \text{const}). \quad (6.40)$$

Note that the first-order terms cancel since we are expanding about a minimum. Furthermore, up to second order there are no terms mixing amplitude fluctuations $\delta\psi$ and phase fluctuations ϕ . We can simplify the expression:

$$\begin{aligned} F[\delta\psi, \phi] &\cong \int d^3r \left[-2\alpha\delta\psi^2 + \frac{1}{2m^*} \left(\frac{\hbar}{i} \nabla \delta\psi \right)^* \cdot \frac{\hbar}{i} \nabla \delta\psi - \frac{\hbar^2}{2m^*} \frac{\alpha}{\beta} (\nabla\phi)^* \nabla\phi \right] \\ &= \sum_{\mathbf{k}} \left[\underbrace{\left(-2\alpha + \frac{\hbar^2 k^2}{2m^*} \right)}_{>0} \delta\psi_{\mathbf{k}}^* \delta\psi_{\mathbf{k}} - \underbrace{\frac{\alpha \hbar^2 k^2}{\beta 2m^*}}_{>0} \phi_{\mathbf{k}}^* \cdot \phi_{\mathbf{k}} \right], \end{aligned} \quad (6.41)$$

in analogy to the case $T > T_c$. We see that amplitude fluctuations are gapped (massive) with an energy gap $-2\alpha = 2\alpha'(T_c - T)$. They are not degenerate. They are called *amplitude modes*.

On the other hand, phase fluctuations are *ungapped (massless)* with quadratic dispersion

$$\epsilon_{\mathbf{k}}^{\phi} = -\frac{\alpha \hbar^2 k^2}{\beta 2m^*}. \quad (6.42)$$

The appearance of ungapped so-called *Goldstone modes* is characteristic for systems with spontaneously broken continuous symmetries. We state without derivation that the heat capacity diverges like $C \sim 1/\sqrt{T_c - T}$ for $T \rightarrow T_c^-$, analogous to the case $T > T_c$.

Time-dependent Ginzburg-Landau theory

The Ginzburg-Landau approach can be extended to describe dynamics. The field $\psi(\mathbf{r}, t)$ is then time dependent. The relevant quantity is the Lagrange-density functional $\mathcal{L}[\psi, \nabla\psi, \dot{\psi}]$ of this field, from which one obtains the action

$$\mathcal{S} = \int_{t_i}^{t_f} dt L = \int_{t_i}^{t_f} dt \int d^3r \mathcal{L}, \quad (6.43)$$

where t_i and t_f are the initial and final time, respectively. Equations of motion for $\psi(\mathbf{r}, t)$ follow from the variational principle $\delta\mathcal{S} = 0$, in analogy to the Lagrange equations in classical mechanics and, even more appositely, the Maxwell equations in electrodynamics.

We only give the main expressions for the case of a neutral superfluid, without derivations. Here,

$$\mathcal{L} = i\hbar\psi^* \frac{\partial\psi}{\partial t} - \alpha |\psi|^2 - \frac{\beta}{2} |\psi|^4 - \frac{\hbar^2}{2m^*} |\nabla\psi|^2 \quad (6.44)$$

so that the Lagrange functional reads

$$L = \int d^3r i\hbar\psi^* \frac{\partial\psi}{\partial t} - F[\psi], \quad (6.45)$$

with the Landau functional F . From $\delta\mathcal{S} = 0$, one then obtains (see the lecture notes on Quantum Theory 2)

$$i\hbar \frac{\partial\psi}{\partial t} = -\frac{\hbar^2}{2m^*} \nabla^2\psi + \alpha\psi + \beta|\psi|^2\psi. \quad (6.46)$$

This equation is consistent with the time-independent limit, Eq. (6.20). It is clearly a nonlinear generalization of the time-dependent Schrödinger equation. It is also called the time-dependent Gross-Pitaevskii equation. The result makes sense since for a noninteracting field ($\beta = 0$) we obtain the single-particle Schrödinger equation.

6.3 Ginzburg-Landau theory for superconductors

To describe superconductors, we have to take the charge q of the particles forming the condensate into account. We allow for the possibility that q is not the electron charge $-e$. Then there are two additional terms in the Landau functional:

- The canonical momentum has to be replaced by the kinetic momentum (minimal coupling):

$$\frac{\hbar}{i}\nabla \rightarrow \frac{\hbar}{i}\nabla - \frac{q}{c}\mathbf{A}, \quad (6.47)$$

where \mathbf{A} is the vector potential.

- The energy density of the magnetic field, $B^2/8\pi$, has to be included.²

If the charge carriers (later to be identified as Cooper pairs) had a nonvanishing spin, there would be an additional term proportional to $\mathbf{B} \cdot \mathbf{S}$. We consider the zero-spin case here, which applies to all conventional and most unconventional superconductors. Thus we obtain the functional

$$\begin{aligned} F[\psi, \mathbf{A}] &\cong \int d^3r \left[\alpha |\psi|^2 + \frac{\beta}{2} |\psi|^4 + \frac{1}{2m^*} \left| \left(\frac{\hbar}{i}\nabla - \frac{q}{c}\mathbf{A} \right) \psi \right|^2 + \frac{B^2}{8\pi} \right] \\ &= \int d^3r \left[\alpha |\psi|^2 + \frac{\beta}{2} |\psi|^4 + \frac{1}{2m^*} \left(\frac{\hbar}{i}\nabla\psi \right)^* \cdot \left(\frac{\hbar}{i}\nabla - \frac{q}{c}\mathbf{A} \right) \psi + \frac{1}{2m^*} \left(-\frac{q}{c}\mathbf{A}\psi \right)^* \cdot \left(\frac{\hbar}{i}\nabla - \frac{q}{c}\mathbf{A} \right) \psi + \frac{B^2}{8\pi} \right] \\ &= \int d^3r \left[\alpha |\psi|^2 + \frac{\beta}{2} |\psi|^4 - \frac{1}{2m^*} \psi^* \left(\frac{\hbar}{i}\nabla \right)^* \cdot \left(\frac{\hbar}{i}\nabla - \frac{q}{c}\mathbf{A} \right) \psi + \frac{1}{2m^*} \psi^* \left(-\frac{q}{c}\mathbf{A} \right) \cdot \left(\frac{\hbar}{i}\nabla - \frac{q}{c}\mathbf{A} \right) \psi + \frac{B^2}{8\pi} \right] \\ &= \int d^3r \left[\alpha |\psi|^2 + \frac{\beta}{2} |\psi|^4 + \frac{1}{2m^*} \psi^* \left(\frac{\hbar}{i}\nabla - \frac{q}{c}\mathbf{A} \right)^2 \psi + \frac{B^2}{8\pi} \right]. \end{aligned} \quad (6.48)$$

Minimizing this free-energy functional with respect to ψ , we obtain, in analogy to the previous section,

$$\frac{1}{2m^*} \left(\frac{\hbar}{i}\nabla - \frac{q}{c}\mathbf{A} \right)^2 \psi + \alpha \psi + \beta |\psi|^2 \psi = 0. \quad (6.49)$$

To minimize F with respect to \mathbf{A} , we write $\mathbf{A}(\mathbf{r}) = \mathbf{A}_0(\mathbf{r}) + \mathbf{a}(\mathbf{r})$ and insert this into the terms containing \mathbf{A} :

$$\begin{aligned} F[\psi, \mathbf{A}_0 + \mathbf{a}] &= F[\psi, \mathbf{A}_0] + \int d^3r \left[\frac{1}{2m^*} \left(\left[\frac{\hbar}{i}\nabla - \frac{q}{c}\mathbf{A}_0 \right] \psi \right)^* \cdot \left(-\frac{q}{c} \right) \mathbf{a}\psi \right. \\ &\quad \left. + \frac{1}{2m^*} \left(-\frac{q}{c}\mathbf{a}\psi \right)^* \cdot \left(\frac{\hbar}{i}\nabla - \frac{q}{c}\mathbf{A}_0 \right) \psi + \frac{1}{4\pi} \underbrace{(\nabla \times \mathbf{A}_0) \cdot (\nabla \times \mathbf{a})}_{=\mathbf{a} \cdot (\nabla \times \nabla \times \mathbf{A}_0) - \nabla \cdot ((\nabla \times \mathbf{A}_0) \times \mathbf{a})} \right] + \mathcal{O}(a^2) \\ &= F[\psi, \mathbf{A}_0] + \int d^3r \left[-\frac{q}{2m^*c} \left(\left[\frac{\hbar}{i}\nabla\psi \right]^* \psi + \psi^* \frac{\hbar}{i}\nabla\psi \right) \cdot \mathbf{a} \right. \\ &\quad \left. + \frac{q^2}{m^*c^2} |\psi|^2 \mathbf{A}_0 \cdot \mathbf{a} + \frac{1}{4\pi} (\nabla \times \mathbf{B}_0) \cdot \mathbf{a} \right] + \mathcal{O}(a^2), \end{aligned} \quad (6.50)$$

where we have used $\nabla \times \mathbf{A}_0 = \mathbf{B}_0$ and Gauss' theorem. At the minimum, the coefficient of the linear term must vanish. Dropping the subscript, we obtain

$$-i \frac{q\hbar}{2m^*c} ([\nabla\psi^*]\psi - \psi^*\nabla\psi) + \frac{q^2}{m^*c^2} |\psi|^2 \mathbf{A} + \frac{1}{4\pi} \nabla \times \mathbf{B} = 0. \quad (6.51)$$

With Ampère's law we find

$$\mathbf{j} = \frac{c}{4\pi} \nabla \times \mathbf{B} = i \frac{q\hbar}{2m^*} ([\nabla\psi^*]\psi - \psi^*\nabla\psi) - \frac{q^2}{m^*c} |\psi|^2 \mathbf{A}, \quad (6.52)$$

²In principle, one also has to include the energy density of the electric field \mathbf{E} but \mathbf{E} vanishes in equilibrium in any conductor.

where we have dropped the subscript “s” of \mathbf{j} since we assume that the normal current is negligible. Equations (6.49) and (6.52) are called the *Ginzburg-Landau equations*.

In the limit of uniform $\psi(\mathbf{r})$, Eq. (6.52) simplifies to

$$\mathbf{j} = -\frac{q^2 |\psi|^2}{m^* c} \mathbf{A}. \quad (6.53)$$

This should reproduce the London equation

$$\mathbf{j} = -\frac{e^2 n_s}{m c} \mathbf{A}, \quad (6.54)$$

which obviously requires

$$\frac{q^2 |\psi|^2}{m^*} = \frac{e^2 n_s}{m}. \quad (6.55)$$

As noted in Sec. 5.3, based on flux-quantization experiments and on the analogy to Bose-Einstein condensation, it is natural to set $q = -2e$. For m^* one might then insert twice the effective electron (band) mass of the metal. However, it turns out to be difficult to measure m^* independently of the superfluid density n_s and it is therefore common to set $m^* = 2m \equiv 2m_e$. All system-specific properties are thus absorbed into

$$n_s = \frac{m q^2 |\psi|^2}{e^2 m^*} = \frac{m \psi e^2 |\psi|^2}{e^2 2m} = 2 |\psi|^2. \quad (6.56)$$

With this choice of normalization of $\psi(\mathbf{r})$, we have shown that London theory follows as a special case from Ginzburg-Landau theory.

We can now write the penetration depth as

$$\lambda = \sqrt{\frac{m c^2}{4\pi e^2 n_s}} = \sqrt{\frac{m c^2}{8\pi e^2 |\psi|^2}} \cong \sqrt{\frac{m c^2}{8\pi e^2 \left(-\frac{\alpha}{\beta}\right)}}. \quad (6.57)$$

We have found two characteristic length scales:

- λ : penetration of the magnetic field,
- ξ : variation of the coarse-grained superconducting wave function (order parameter).

Within the mean-field theories we have so far employed, both quantities scale as

$$\lambda, \xi \propto \frac{1}{\sqrt{T_c - T}} \quad (6.58)$$

close to T_c . Thus their dimensionless ratio

$$\kappa := \frac{\lambda(T)}{\xi(T)} \quad (6.59)$$

is roughly temperature independent. It is called the *Ginzburg-Landau parameter* and turns out to be very important for the behavior of superconductors in an applied magnetic field. For elemental superconductors, κ is small compared to unity, i.e., the \mathbf{B} field is less stiff than the wave function.

Fluctuations and the Anderson-Higgs mechanism

When discussing fluctuations about the mean-field state of a superconductor, we have to take the coupling to the electromagnetic field into account. We proceed analogously to the case of a neutral superfluid and employ the Gaussian approximation throughout. For $T > T_c$, we note that the kinetic term

$$\frac{1}{2m^*} \left| \left(\frac{\hbar}{i} \nabla - \frac{q}{c} \mathbf{A} \right) \psi \right|^2 \quad (6.60)$$

is explicitly of second order in the fluctuations $\delta\psi = \psi$ so that electromagnetic-field fluctuations appear only in higher orders. Thus to second order, the order-parameter fluctuations decouple from the electromagnetic fluctuations,

$$F[\psi, \mathbf{B}] \cong \int d^3r \left[\alpha \psi^*(\mathbf{r})\psi(\mathbf{r}) + \frac{1}{2m^*} \left| \frac{\hbar}{i} \nabla \psi \right|^2 + \frac{B^2}{8\pi} \right] = \sum_{\mathbf{k}} \left(\alpha + \frac{\hbar^2 k^2}{2m^*} \right) \psi_{\mathbf{k}}^* \psi_{\mathbf{k}} + \sum_{\mathbf{k}} \frac{\mathbf{B}_{\mathbf{k}}^* \cdot \mathbf{B}_{\mathbf{k}}}{8\pi}. \quad (6.61)$$

The superconducting fluctuations consist of two degenerate massive branches with dispersion $\epsilon_{\mathbf{k}} = \alpha + \hbar^2 k^2 / 2m^*$, like for the neutral superfluid. The magnetic-field fluctuations decouple and are those of a free field.

The case of $T < T_c$ is more interesting. Writing, as above, $\psi = (\psi_0 + \delta\psi) e^{i\phi}$, we obtain to second order

$$\begin{aligned} F[\delta\psi, \phi, \mathbf{A}] &\cong \int d^3r \left[\cancel{2\alpha\psi_0\delta\psi + 2\beta\psi_0^3\delta\psi} + \alpha\delta\psi^2 + 3\beta\psi_0^2\delta\psi^2 + \frac{1}{2m^*} \left(\frac{\hbar}{i} \nabla \delta\psi \right)^* \cdot \frac{\hbar}{i} \nabla \delta\psi \right. \\ &\quad + \frac{1}{2m^*} \left(\left(\frac{\hbar}{i} \nabla \delta\psi \right)^* \cdot \hbar\psi_0 \nabla \phi + (\hbar\psi_0 \nabla \phi)^* \cdot \frac{\hbar}{i} \nabla \delta\psi \right) + \frac{1}{2m^*} (\hbar\psi_0 \nabla \phi)^* \cdot \hbar\psi_0 \nabla \phi \\ &\quad + \frac{1}{2m^*} \left(\left(\frac{\hbar}{i} \nabla \delta\psi \right)^* \cdot \left(-\frac{q}{c} \right) \mathbf{A}\psi_0 + \left(-\frac{q}{c} \mathbf{A}\psi_0 \right)^* \cdot \frac{\hbar}{i} \nabla \delta\psi \right) \\ &\quad + \frac{1}{2m^*} \left((\hbar\psi_0 \nabla \phi)^* \cdot \left(-\frac{q}{c} \right) \mathbf{A}\psi_0 + \left(-\frac{q}{c} \mathbf{A}\psi_0 \right)^* \cdot \hbar\psi_0 \nabla \phi \right) \\ &\quad \left. + \frac{1}{2m^*} \left(-\frac{q}{c} \mathbf{A}\psi_0 \right)^* \cdot \left(-\frac{q}{c} \right) \mathbf{A}\psi_0 + \frac{1}{8\pi} (\nabla \times \mathbf{A})^* \cdot (\nabla \times \mathbf{A}) \right] (+ \text{const}) \\ &= \int d^3r \left[-2\alpha\delta\psi^2 + \frac{1}{2m^*} \left(\frac{\hbar}{i} \nabla \delta\psi \right)^* \cdot \frac{\hbar}{i} \nabla \delta\psi \right. \\ &\quad \left. - \frac{\hbar^2}{2m^*} \frac{\alpha}{\beta} \left(\nabla \phi - \frac{q}{\hbar c} \mathbf{A} \right)^* \cdot \left(\nabla \phi - \frac{q}{\hbar c} \mathbf{A} \right) + \frac{1}{8\pi} (\nabla \times \mathbf{A})^* \cdot (\nabla \times \mathbf{A}) \right]. \quad (6.62) \end{aligned}$$

Importantly, the phase ϕ of the macroscopic wave function and the vector potential appear in the combination $\nabla \phi - (q/\hbar c)\mathbf{A}$. Physical properties are invariant under the gauge transformation

$$\mathbf{A} \rightarrow \mathbf{A} + \nabla \chi, \quad (6.63)$$

$$\Phi \rightarrow \Phi - \frac{1}{c} \dot{\chi}, \quad (6.64)$$

$$\psi \rightarrow e^{iq\chi/\hbar c} \psi, \quad (6.65)$$

where Φ is the scalar electric potential and $\chi(\mathbf{r}, t)$ is an arbitrary scalar field. We make use of this gauge invariance by choosing

$$\chi = -\frac{\hbar c}{q} \phi. \quad (6.66)$$

Under the corresponding gauge transformation, we get

$$\mathbf{A} \rightarrow \mathbf{A} - \frac{\hbar c}{q} \nabla \phi =: \mathbf{A}', \quad (6.67)$$

$$\psi = (\psi_0 + \delta\psi) e^{i\phi} \rightarrow (\psi_0 + \delta\psi) e^{-i\phi+i\phi} = \psi_0 + \delta\psi. \quad (6.68)$$

The macroscopic wave function becomes purely real (and positive). The Landau functional thus transforms into

$$\begin{aligned} F[\delta\psi, \phi, \mathbf{A}] \rightarrow F[\delta\psi, \mathbf{A}'] &\cong \int d^3r \left[-2\alpha\delta\psi^2 + \frac{1}{2m^*} \left(\frac{\hbar}{i} \nabla \delta\psi \right)^* \cdot \frac{\hbar}{i} \nabla \delta\psi \right. \\ &\quad \left. - \frac{\alpha}{\beta} \frac{q^2}{2m^* c^2} (\mathbf{A}')^* \cdot \mathbf{A}' + \frac{1}{8\pi} (\nabla \times \mathbf{A}')^* \cdot (\nabla \times \mathbf{A}') \right] \quad (6.69) \end{aligned}$$

(note that $\nabla \times \mathbf{A}' = \nabla \times \mathbf{A}$). Thus the phase no longer appears in F ; it has been *absorbed into the vector potential*. Furthermore, dropping the prime, we obtain

$$\begin{aligned} F[\delta\psi, \mathbf{A}] &\cong \sum_{\mathbf{k}} \left[\left(-2\alpha + \frac{\hbar^2 k^2}{2m^*} \right) \delta\psi_{\mathbf{k}}^* \delta\psi_{\mathbf{k}} - \frac{\alpha}{\beta} \frac{q^2}{2m^* c^2} \mathbf{A}_{\mathbf{k}}^* \cdot \mathbf{A}_{\mathbf{k}} + \frac{1}{8\pi} (\mathbf{k} \times \mathbf{A}_{\mathbf{k}})^* \cdot (\mathbf{k} \times \mathbf{A}_{\mathbf{k}}) \right] \\ &= \sum_{\mathbf{k}} \left[\left(-2\alpha + \frac{\hbar^2 k^2}{2m^*} \right) \delta\psi_{\mathbf{k}}^* \delta\psi_{\mathbf{k}} - \frac{\alpha}{\beta} \frac{q^2}{2m^* c^2} \mathbf{A}_{\mathbf{k}}^* \cdot \mathbf{A}_{\mathbf{k}} + \frac{k^2}{8\pi} \mathbf{A}_{\mathbf{k}}^* \cdot \mathbf{A}_{\mathbf{k}} - \frac{1}{8\pi} (\mathbf{k} \cdot \mathbf{A}_{\mathbf{k}}^*) (\mathbf{k} \cdot \mathbf{A}_{\mathbf{k}}) \right]. \end{aligned} \quad (6.70)$$

Obviously, amplitude fluctuations decouple from electromagnetic fluctuations and behave like for a neutral superfluid. The amplitude modes are now called *Higgs modes*.

We discuss the electromagnetic fluctuations further. The term proportional to α/β is due to superconductivity. Without it, we would have the free-field functional

$$F_{\text{free}}[\mathbf{A}] = \sum_{\mathbf{k}} \frac{1}{8\pi} \left[k^2 \mathbf{A}_{\mathbf{k}}^* \cdot \mathbf{A}_{\mathbf{k}} - (\mathbf{k} \cdot \mathbf{A}_{\mathbf{k}}^*) (\mathbf{k} \cdot \mathbf{A}_{\mathbf{k}}) \right]. \quad (6.71)$$

Decomposing \mathbf{A} into longitudinal and transverse components,

$$\mathbf{A}_{\mathbf{k}} = \underbrace{\hat{\mathbf{k}}(\hat{\mathbf{k}} \cdot \mathbf{A}_{\mathbf{k}})}_{=: \mathbf{A}_{\mathbf{k}}^{\parallel}} + \underbrace{\mathbf{A}_{\mathbf{k}} - \hat{\mathbf{k}}(\hat{\mathbf{k}} \cdot \mathbf{A}_{\mathbf{k}})}_{=: \mathbf{A}_{\mathbf{k}}^{\perp}} \quad (6.72)$$

with $\hat{\mathbf{k}} := \mathbf{k}/k$, we obtain

$$\begin{aligned} F_{\text{free}}[\mathbf{A}] &= \sum_{\mathbf{k}} \frac{1}{8\pi} \left[k^2 \mathbf{A}_{\mathbf{k}}^{\parallel*} \cdot \mathbf{A}_{\mathbf{k}}^{\parallel} + k^2 \mathbf{A}_{\mathbf{k}}^{\perp*} \cdot \mathbf{A}_{\mathbf{k}}^{\perp} - (\mathbf{k} \cdot \mathbf{A}_{\mathbf{k}}^{\parallel*}) (\mathbf{k} \cdot \mathbf{A}_{\mathbf{k}}^{\parallel}) \right] \\ &= \sum_{\mathbf{k}} \frac{1}{8\pi} \left[\cancel{k^2 \mathbf{A}_{\mathbf{k}}^{\parallel*} \cdot \mathbf{A}_{\mathbf{k}}^{\parallel}} + k^2 \mathbf{A}_{\mathbf{k}}^{\perp*} \cdot \mathbf{A}_{\mathbf{k}}^{\perp} - \cancel{k^2 \mathbf{A}_{\mathbf{k}}^{\parallel*} \cdot \mathbf{A}_{\mathbf{k}}^{\parallel}} \right] = \sum_{\mathbf{k}} \frac{1}{8\pi} k^2 \mathbf{A}_{\mathbf{k}}^{\perp*} \cdot \mathbf{A}_{\mathbf{k}}^{\perp}. \end{aligned} \quad (6.73)$$

Thus only the two *transverse* components appear—only they are degrees of freedom of the free electromagnetic field.³ They do not have an energy gap.

Including the superconducting contribution, we get

$$F[\mathbf{A}] \cong \sum_{\mathbf{k}} \left[-\frac{\alpha}{\beta} \frac{q^2}{2m^* c^2} \mathbf{A}_{\mathbf{k}}^{\parallel*} \cdot \mathbf{A}_{\mathbf{k}}^{\parallel} - \frac{\alpha}{\beta} \frac{q^2}{2m^* c^2} \mathbf{A}_{\mathbf{k}}^{\perp*} \cdot \mathbf{A}_{\mathbf{k}}^{\perp} + \frac{1}{8\pi} k^2 \mathbf{A}_{\mathbf{k}}^{\perp*} \cdot \mathbf{A}_{\mathbf{k}}^{\perp} \right]. \quad (6.74)$$

All *three* components of \mathbf{A} appear now, the longitudinal one has been introduced by absorbing the phase $\phi(\mathbf{r})$. Even more importantly, all components obtain a term with a constant coefficient, i.e., a *mass term*. Thus the electromagnetic field inside a superconductor becomes massive. This is the famous *Anderson-Higgs mechanism*. The same general idea is also thought to explain (most of) the masses of elementary particles, although in a more complicated case (the broken symmetry is more complicated than the U(1) symmetry of superconductivity). The ‘‘Higgs bosons’’ in our case are the amplitude-fluctuation modes described by $\delta\psi$. Contrary to what is said in popular discussions, they are not *responsible* for giving mass to the field \mathbf{A} . Rather, they are left over when the phase fluctuations are eaten by the field \mathbf{A} .

The mass term in the superconducting case can be thought of as leading to the Meißner effect (finite penetration depth λ). Indeed, we can write

$$F[\delta\psi, \mathbf{A}] \cong \sum_{\mathbf{k}} \left(-2\alpha + \frac{\hbar^2 k^2}{2m^*} \right) \delta\psi_{\mathbf{k}}^* \delta\psi_{\mathbf{k}} + \sum_{\mathbf{k}} \frac{1}{8\pi} \left[\frac{1}{\lambda^2} \mathbf{A}_{\mathbf{k}}^* \cdot \mathbf{A}_{\mathbf{k}} + k^2 \mathbf{A}_{\mathbf{k}}^* \cdot \mathbf{A}_{\mathbf{k}} - (\mathbf{k} \cdot \mathbf{A}_{\mathbf{k}}^*) (\mathbf{k} \cdot \mathbf{A}_{\mathbf{k}}) \right]. \quad (6.75)$$

The photon mass is proportional to $1/\lambda$. (To see that the dispersion relation is $\hbar^2 \omega^2 = m^2 c^4 + p^2 c^2$, we would have to consider the full action including a temporal integral over F and terms containing time-derivatives.)

³This result persists in quantum electrodynamics: Since the electromagnetic field is a spin-one field one would naively expect it to have three independent degrees of freedom at each momentum, corresponding to the three magnetic quantum numbers $-1, 0, +1$. However, for a massless field, the longitudinal component is not a dynamical field (it is fully determined by the charges) and the electromagnetic field thus only has two degrees of freedom per momentum. These can be described as photons with positive and negative helicity, i.e., with spin parallel or antiparallel to their momentum, respectively.

Elitzur's theorem

One sometimes reads that in the superconducting state gauge symmetry is broken. This is not correct. Gauge symmetry is the invariance under local gauge transformations. S. Elitzur showed in 1975 that a local gauge symmetry cannot be spontaneously broken. Rather, superconductors and superfluids spontaneously break a *global* $U(1)$ symmetry in that the ordered state has a preferred *macroscopic phase*, as noted above.

6.4 Type-I superconductors

Superconductors with small Ginzburg-Landau parameter $\kappa = \lambda/\xi$ are said to be of *type I*. The exact condition is

$$\kappa < \frac{1}{\sqrt{2}}. \quad (6.76)$$

It turns out that these superconductors have a uniform state in an applied magnetic field, at least for simple geometries such as a thin cylinder parallel to the applied field.

The appropriate thermodynamic potential for describing a superconductor in an applied magnetic field is the Gibbs free energy G (natural variable \mathbf{H}) and not the Helmholtz free energy F (natural variable \mathbf{B}), which we have used so far. The reason is that the magnetic field \mathbf{H} , not the magnetic induction \mathbf{B} , is controlled by the experimenter. The two potentials are related by the Legendre transformation

$$G = F - \int d^3r \frac{\mathbf{H} \cdot \mathbf{B}}{4\pi}. \quad (6.77)$$

Since the equilibrium state in the bulk is uniform the order parameter is $|\psi| = \sqrt{-\alpha/\beta}$ and the magnetic induction \mathbf{B} as well as the vector potential (in the London gauge) vanish. Thus the Gibbs free-energy density is

$$g_s = f_s = \alpha |\psi|^2 + \frac{\beta}{2} |\psi|^4 = -\frac{\alpha^2}{\beta} + \frac{\beta}{2} \frac{\alpha^2}{\beta^2} = -\frac{\alpha^2}{2\beta}. \quad (6.78)$$

On the other hand, in the normal state ψ vanishes, but the field penetrates the system and $\mathbf{B} \equiv \mathbf{H}$ so that

$$g_n = f_n - \frac{HB}{4\pi} = \frac{B^2}{8\pi} - \frac{HB}{4\pi} = -\frac{H^2}{8\pi}. \quad (6.79)$$

The system will only become superconducting if this reduces the Gibbs free energy, i.e., if

$$g_s - g_n = -\frac{\alpha^2}{2\beta} + \frac{H^2}{8\pi} < 0. \quad (6.80)$$

Thus in an applied magnetic field of $H \geq H_c$, with the *critical field*

$$H_c(T) := \sqrt{4\pi \frac{\alpha^2}{\beta}}, \quad (6.81)$$

superconductivity does not occur.

We can use the relation (6.81) and

$$\lambda^2(T) = \frac{mc^2}{8\pi e^2 |\psi|^2} = -\frac{mc^2}{8\pi e^2} \frac{\beta}{\alpha} \quad (6.82)$$

to express the phenomenological parameters α and β in terms of the measurable quantities λ and H_c :

$$\alpha = -\frac{2e^2}{mc^2} \lambda^2 H_c^2, \quad (6.83)$$

$$\beta = 4\pi \left(\frac{2e^2}{mc^2} \right)^2 \lambda^4 H_c^2. \quad (6.84)$$

Domain-wall energy and intermediate states

We can now calculate the energy per area of a domain wall between superconducting and normal regions. We assume that $\psi(\mathbf{r})$ is only a function of x and impose the boundary conditions

$$\psi(x) \rightarrow \begin{cases} \psi_\infty := \sqrt{-\alpha/\beta} & \text{for } x \rightarrow \infty, \\ 0 & \text{for } x \rightarrow -\infty. \end{cases} \quad (6.85)$$

What are reasonable boundary conditions for the local induction $B(x)$? In the superconductor we have

$$B(x) \rightarrow 0 \quad \text{for } x \rightarrow \infty. \quad (6.86)$$

At the other end, if we have $\lim_{x \rightarrow -\infty} B(x) > H_c$ the bulk superconductor has a higher Gibbs free-energy density than the normal conductor, as seen above. Thus superconductivity is not stable. For $\lim_{x \rightarrow -\infty} B(x) < H_c$, the Gibbs free-energy density of the superconductor is lower and it eats up the normal phase. Thus a domain wall can only be stable for

$$B(x) \rightarrow H_c = \sqrt{4\pi \frac{\alpha^2}{\beta}} \quad \text{for } x \rightarrow -\infty, \quad (6.87)$$

which we will assume from now on. This obviously requires fine tuning that cannot be done exactly in the real world. Nevertheless, we can get useful insight since domain walls can occur, without fine tuning, for less trivial geometries, as we will see.

Technically, we have to solve the Ginzburg-Landau equations under these boundary conditions, which can only be done numerically. The qualitative form of the solution is clear, though:

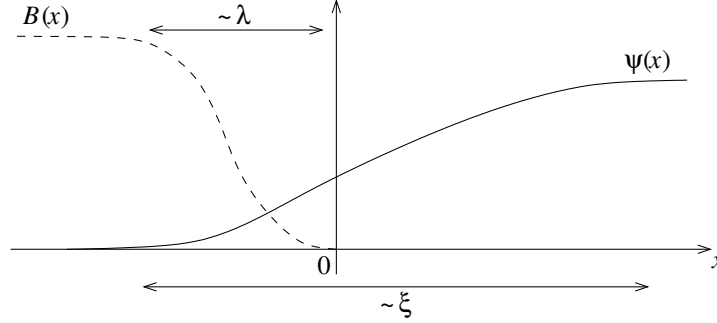

The Gibbs free energy of the domain wall, per unit area, will be denoted by γ . To derive it, first note that for the given boundary conditions, $g_s(x \rightarrow \infty) = g_n(x \rightarrow -\infty)$, i.e., the superconducting free-energy density deep inside the superconductor equals the normal free-energy density deep inside the normal conductor. This bulk Gibbs free-energy density is, as derived above,

$$g_s(x \rightarrow \infty) = g_n(x \rightarrow -\infty) = f_n(x \rightarrow -\infty) - \frac{H_c^2}{4\pi} = -\frac{H_c^2}{8\pi}. \quad (6.88)$$

The additional free-energy density due to the domain wall is

$$g_s(x) - \left(-\frac{H_c^2}{8\pi}\right) = g_s(x) + \frac{H_c^2}{8\pi}. \quad (6.89)$$

The corresponding free energy per area is

$$\begin{aligned} \gamma &= \int_{-\infty}^{\infty} dx \left[g_s(x) + \frac{H_c^2}{8\pi} \right] \\ &= \int_{-\infty}^{\infty} dx \left[\overbrace{f_s(x) - \frac{B(x)H_c}{4\pi}} + \frac{H_c^2}{8\pi} \right] \quad \Big| \quad \text{using that } H(x) = \text{const} = H_c \end{aligned}$$

$$= \int_{-\infty}^{\infty} dx \left[\alpha |\psi|^2 + \frac{\beta}{2} |\psi|^4 + \frac{1}{2m^*} \left| \left(\frac{\hbar}{i} \hat{\mathbf{x}} \frac{\partial}{\partial x} - \frac{q}{c} A(x) \hat{\mathbf{y}} \right) \psi \right|^2 + \underbrace{\frac{B^2}{8\pi} - \frac{BH_c}{4\pi} + \frac{H_c^2}{8\pi}}_{=(B-H_c)^2/8\pi} \right], \quad (6.90)$$

where we have used $\mathbf{B} = \hat{\mathbf{z}} B(x)$ and the gauge choice $\mathbf{A} = \hat{\mathbf{y}} A(x)$, which requires $B = \partial A / \partial x$.

We can simplify this expression by multiplying the first Ginzburg-Landau equation (6.49) by ψ^* and integrating over x :

$$\begin{aligned} 0 &= \int_{-\infty}^{\infty} dx \left[\alpha |\psi|^2 + \beta |\psi|^4 + \frac{1}{2m^*} \psi^* \left(\frac{\hbar}{i} \hat{\mathbf{x}} \frac{\partial}{\partial x} - \frac{q}{c} A(x) \hat{\mathbf{y}} \right)^2 \psi \right] \\ \text{by parts} &\equiv \int_{-\infty}^{\infty} dx \left[\alpha |\psi|^2 + \beta |\psi|^4 + \frac{1}{2m^*} \left(-\frac{\hbar}{i} \hat{\mathbf{x}} \frac{\partial}{\partial x} - \frac{q}{c} A(x) \hat{\mathbf{y}} \right) \psi^* \cdot \left(\frac{\hbar}{i} \hat{\mathbf{x}} \frac{\partial}{\partial x} - \frac{q}{c} A(x) \hat{\mathbf{y}} \right) \psi \right] \quad \left| \text{see Eq. (6.48)} \right. \\ &= \int_{-\infty}^{\infty} dx \left[\alpha |\psi|^2 + \beta |\psi|^4 + \frac{1}{2m^*} \left| \left(\frac{\hbar}{i} \hat{\mathbf{x}} \frac{\partial}{\partial x} - \frac{q}{c} A(x) \hat{\mathbf{y}} \right) \psi \right|^2 \right]. \end{aligned} \quad (6.91)$$

Thus

$$\begin{aligned} \gamma &= \int_{-\infty}^{\infty} dx \left[-\frac{\beta}{2} |\psi|^4 + \frac{(B-H_c)^2}{8\pi} \right] = \frac{H_c^2}{8\pi} \int_{-\infty}^{\infty} dx \left[-\beta \frac{|\psi|^4}{\alpha^2} + \left(1 - \frac{B}{H_c} \right)^2 \right] \\ &= \frac{H_c^2}{8\pi} \int_{-\infty}^{\infty} dx \left[\left(1 - \frac{B}{H_c} \right)^2 - \frac{|\psi|^4}{\psi_\infty^4} \right], \end{aligned} \quad (6.92)$$

where we have drawn out the characteristic energy density $H_c^2/8\pi$. The domain wall energy is given by the difference of the energy *cost* of expelling the magnetic field and the energy *gain* due to superconducting condensation. For strong type-I superconductors, $\xi \gg \lambda$, there is a region of thickness $\xi - \lambda > 0$ in which the first term is already large, while the second only slowly approaches its bulk value (see sketch above). Thus $\gamma > 0$ for strong type-I superconductors. One can show that $\gamma > 0$ persists for all $\kappa < 1/\sqrt{2}$. Type-I superconductors therefore tend to *minimize* the total area of domain walls.

Note that even in samples of relatively simple shape, magnetic flux *will* penetrate for nonzero applied field. It will do so in a way that minimizes the total Gibbs free energy, only one contribution to which is the domain-wall energy. For example, in a large slab perpendicular to the applied field, the flux has to penetrate in some manner since going around the large sample would cost much energy. A careful analysis shows that this will usually happen in the form of normal stripes separated by superconducting stripes, see Tinkham's book. Such a state is called an *intermediate state*. It should not be confused with the vortex state to be discussed later.

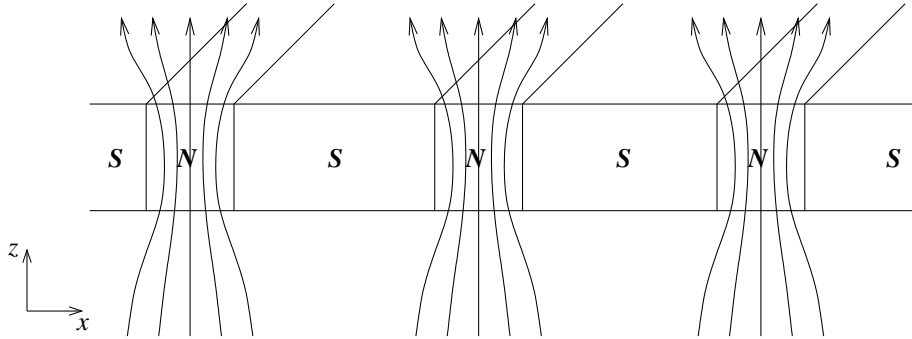

6.5 Type-II superconductors

Type-II superconductors are defined by a large Ginzburg-Landau parameter

$$\kappa > \frac{1}{\sqrt{2}}. \quad (6.93)$$

The analysis in the previous section goes through. But now domain walls have a region where the condensate is nearly fully developed but the flux is not completely expelled.

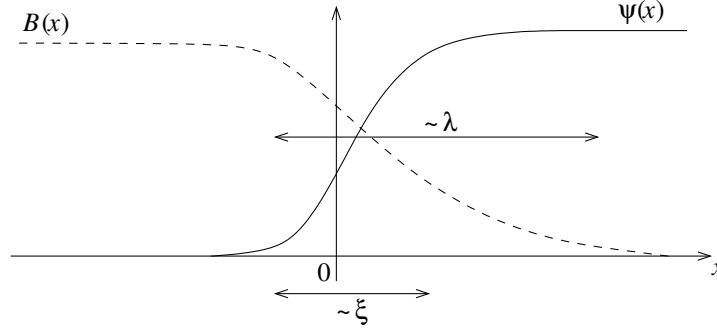

Therefore, the domain-wall energy is *negative*, $\gamma < 0$. Hence, the system tends to *maximize* the total area of domain walls. This tendency should be counterbalanced by some other effect, otherwise the system would become inhomogeneous on microscopic (atomic) length scales and Ginzburg-Landau theory would break down. The effect in question is flux quantization—the penetrating magnetic flux cannot be split into portions smaller than the flux quantum $\Phi_0 = hc/2e$, see Sec. 5.3.

Fluxoid quantization

We now revisit the quantization of magnetic flux. Consider an arbitrary closed path ∂S forming the edge of a surface S , where at least the edge ∂S must lie inside a superconductor,

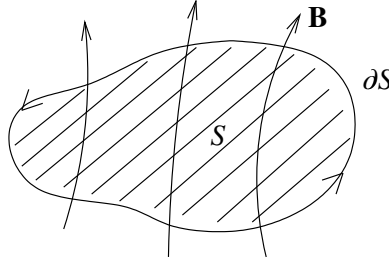

The magnetic flux Φ through this loop is

$$\Phi = \int_S d\mathbf{a} \cdot \mathbf{B} = \int_S d\mathbf{a} \cdot (\nabla \times \mathbf{A}) \stackrel{\text{Stokes}}{=} \oint_{\partial S} d\mathbf{s} \cdot \mathbf{A}. \quad (6.94)$$

With the second Ginzburg-Landau equation

$$\mathbf{j} = i \frac{q\hbar}{2m^*} ([\nabla\psi^*] \psi - \psi^* \nabla\psi) - \frac{q^2}{m^*c} |\psi|^2 \mathbf{A} \quad (6.95)$$

solved for \mathbf{A} , we obtain

$$\Phi = \oint_{\partial S} d\mathbf{s} \cdot \left\{ -\frac{m^*c}{q^2 |\psi|^2} \mathbf{j} + i \frac{\hbar c}{2q |\psi|^2} ([\nabla\psi^*] \psi - \psi^* \nabla\psi) \right\}$$

$$\begin{aligned}
&= \oint_{\partial S} d\mathbf{s} \cdot \left\{ -\frac{mc}{e^2 n_s} \mathbf{j} + i \frac{\hbar c}{2q} (-2i) \nabla \phi \right\} \\
&= \frac{mc}{e} \oint_{\partial S} d\mathbf{s} \cdot \mathbf{v}_s - \frac{\hbar c}{2e} \oint_{\partial S} d\mathbf{s} \cdot \nabla \phi,
\end{aligned} \tag{6.96}$$

where $\mathbf{v}_s := -\mathbf{j}/en_s$ is the superfluid velocity. The last term contains the change of the phase of the macroscopic wave function along the whole path, which must be an integer multiple of 2π for $\psi(\mathbf{r})$ to be continuous:

$$\oint_{\partial S} d\mathbf{s} \cdot \nabla \phi = -2\pi n, \quad n \in \mathbb{Z}. \tag{6.97}$$

The minus sign is a convention, which is useful for negatively charged condensates. Thus we find for the so-called *fluxoid*

$$\Phi' := \Phi - \frac{mc}{e} \oint_{\partial S} d\mathbf{s} \cdot \mathbf{v}_s = \frac{\hbar c}{2e} 2\pi n = \frac{\hbar c}{2e} n = n\Phi_0, \quad n \in \mathbb{Z}. \tag{6.98}$$

We see that it is not the flux but the fluxoid Φ' that is quantized. However, deep inside a superconducting region, the current vanishes and Φ' equals Φ .

Vortices

The smallest amount of fluxoid that can penetrate a superconductor is one flux quantum Φ_0 . It does so as a *vortex* (or *vortex line*).

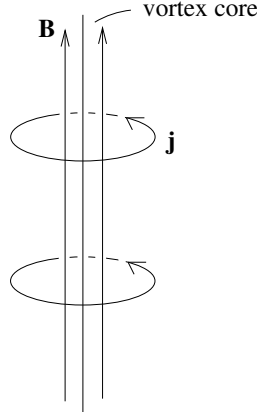

Following the above arguments, the phase ϕ of ψ changes by -2π as one circles a vortex in the positive direction, where, by convention, the direction of a vortex is the direction of the magnetic field \mathbf{B} . Thus in the center of the vortex line (the *vortex core*), the phase is undefined. This is only consistent with a continuous ψ if $\psi = 0$ in the vortex core. Because of the phase winding, a vortex cannot end anywhere in the interior of a superconductor. Vortices can thus only terminate at a surface or form closed loops. One can understand the winding of the phase as a *topological* property of the vortex since it cannot be changed by any continuous deformation of $\psi(\mathbf{r})$ unless ψ is tuned to zero. In this sense, vortices are called *topological defects* of the superconducting condensate.

For a vortex along the z -axis we choose cylindrical coordinates ϱ, φ, z . We then have to solve the Ginzburg-Landau equations together with Ampère's law with the boundary conditions

$$\psi(\varrho = 0) = 0, \tag{6.99}$$

$$|\psi(\varrho \rightarrow \infty)| = \psi_0, \tag{6.100}$$

$$\mathbf{B}(\varrho \rightarrow \infty) = 0. \tag{6.101}$$

From symmetry, we have

$$\psi(\mathbf{r}) = |\psi|(\varrho) e^{i\phi} = |\psi|(\varrho) e^{-i\varphi}, \quad (6.102)$$

$$\mathbf{v}_s(\mathbf{r}) = \hat{\varphi} v_s(\varrho), \quad (6.103)$$

$$\mathbf{B}(\mathbf{r}) = \hat{z} B(\varrho) \quad (6.104)$$

and we can choose

$$\mathbf{A}(\mathbf{r}) = \hat{\varphi} A(\varrho) \quad (6.105)$$

so that

$$B(\varrho) = \frac{1}{\varrho} \frac{\partial}{\partial \varrho} \varrho A(\varrho). \quad (6.106)$$

Choosing a circular integration path of radius r centered at the vortex core, the enclosed fluxoid is

$$\begin{aligned} \Phi'(r) &= \Phi(r) - \frac{mc}{e} \oint_{\partial S} d\mathbf{s} \cdot \mathbf{v}_s = 2\pi r A(r) - \frac{mc}{e} 2\pi r v_s(r) \stackrel{!}{=} \Phi_0 \\ \Rightarrow A(r) - \frac{mc}{e} v_s(r) &= \frac{\Phi_0}{2\pi r}. \end{aligned} \quad (6.107)$$

This relation follows from fluxoid quantization and thus ultimately from the second Ginzburg-Landau equation. To obtain $\mathbf{j}(\mathbf{r})$, $\psi(\mathbf{r})$, and $\mathbf{A}(\mathbf{r})$, one has to use the first Ginzburg-Landau equation

$$\frac{1}{4m} \left(\frac{\hbar}{i} \nabla + \frac{2e}{c} \mathbf{A} \right)^2 \psi + \alpha \psi + \beta |\psi|^2 \psi = 0 \quad (6.108)$$

and Ampère's Law

$$\mathbf{j} = \frac{c}{4\pi} \nabla \times \mathbf{B}. \quad (6.109)$$

This cannot be done analytically because of the nonlinear term $\beta |\psi|^2 \psi$. For small distances ϱ from the core, one can drop this term, thereby linearizing the Ginzburg-Landau equation. The solution is still complicated, the result is that $|\psi|$ increases *linearly* in ϱ . Numerical integration of the full equations gives the results sketched here for a cut through the vortex core:

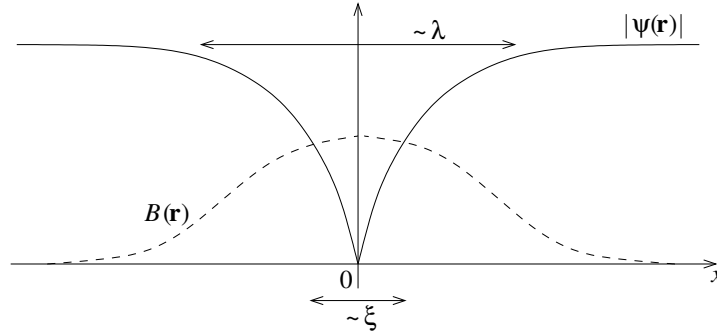

Another useful quantity is the free energy per unit length of a vortex line (its *line tension*). An analytical expression can be obtained in the strong type-II case of $\kappa \gg 1$. We only give the result here: The vortex line tension is

$$\epsilon_v \approx \left(\frac{\Phi_0}{4\pi\lambda} \right)^2 \ln \kappa = \frac{H_c^2}{8\pi} 4\pi\xi^2 \ln \kappa. \quad (6.110)$$

We can now calculate the field for which the first vortex enters the superconductor, the so-called *lower critical field* H_{c1} . This happens when the Gibbs free energy for a superconductor without vortices (Meißner phase) equals the Gibbs free energy in the presence of a single vortex. We assume the sample to have cross section A and thickness L , parallel to the applied field.

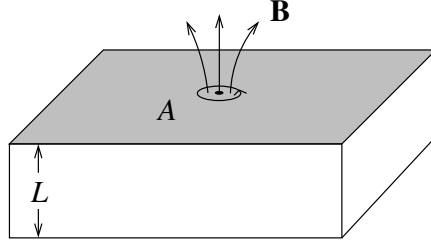

Then we have the condition

$$\begin{aligned}
0 &= G_{\text{one vortex}} - G_{\text{no vortex}} \\
&= \mathcal{F}_s + L\epsilon_v - \frac{1}{4\pi} \int d^3r \mathbf{H} \cdot \mathbf{B} - \mathcal{F}_s + 0 \\
&= L\epsilon_v - \frac{H_{c1}}{4\pi} \int d^3r B(\mathbf{r}) \\
&= L\epsilon_v - \frac{H_{c1}L}{4\pi} \Phi_0.
\end{aligned} \tag{6.111}$$

Thus

$$H_{c1} = \frac{4\pi\epsilon_v}{\Phi_0}. \tag{6.112}$$

The line tension in Eq. (6.110) can also be written as

$$\epsilon_v = \sqrt{\epsilon_v} \sqrt{\epsilon_v} \approx \frac{\Phi_0}{4\pi\lambda} \frac{H_c \xi}{\sqrt{2}} \ln \kappa = \frac{\Phi_0}{4\pi} \frac{H_c}{\sqrt{2}} \frac{\ln \kappa}{\kappa} \tag{6.113}$$

so that

$$H_{c1} = \frac{H_c}{\sqrt{2}} \frac{\ln \kappa}{\kappa}. \tag{6.114}$$

Recall that this expression only holds for $\kappa \gg 1$, where thus $H_{c1} \ll H_c$. H_c is the *thermodynamic critical field* defined above. In a type-II superconductor, nothing interesting happens at $H = H_c$.

The Abrikosov vortex lattice

We have considered the structure of an isolated vortex line. How does a finite magnetic flux penetrate a type-II superconductor? Based on Ginzburg-Landau theory, A. A. Abrikosov proposed in 1957 that flux should enter as a periodic lattice of parallel vortex lines carrying a single flux quantum each. He proposed a square lattice, which was due to a small mistake. The lowest-free-energy state is actually a *triangular lattice*.

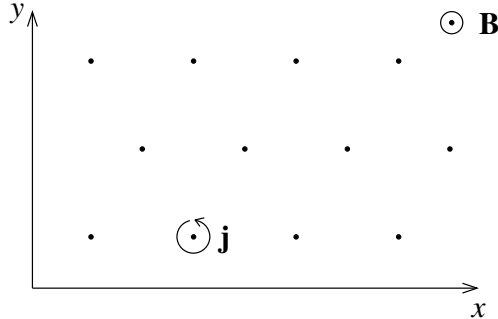

As noted above, the magnetic flux starts to penetrate the superconductor at the *lower critical field* H_{c1} . Furthermore, since flux expulsion in type-II superconductors is not required to be perfect they can withstand stronger magnetic fields than type-I superconductors, up to an *upper critical field* H_{c2} , which is larger than H_c and H_{c1} .

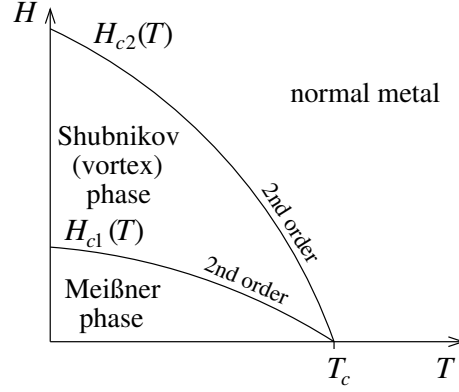

We will now review the basic ideas of Abrikosov's approach. Abrikosov's results are quantitatively valid only close to H_{c2} since he assumed the magnetic flux density \mathbf{B} to be uniform, which is valid for

$$\lambda \gg l, \quad (6.115)$$

where

$$l = \sqrt{\frac{\Phi_0}{B}} \quad (6.116)$$

is the typical distance between vortices (B/Φ_0 is the two-dimensional concentration of vortex lines). The magnetic flux associated with neighboring vortices then strongly overlaps. For $\mathbf{B} = B\hat{z} = \text{const} \approx H\hat{z}$ (close to H_{c2} !) we can choose the gauge $\mathbf{A} = \hat{y}Hx$. Then the first Ginzburg-Landau equation becomes (note $m^* = 2m$)

$$\frac{1}{2m^*} \left(\frac{\hbar}{i} \nabla + \frac{2eH}{c} \hat{y}x \right)^2 \psi + \alpha \psi + \beta |\psi|^2 \psi = 0. \quad (6.117)$$

Slightly below H_{c2} , $|\psi|$ is expected to be small (this should be checked!) so that we can neglect the nonlinear term. Introducing the cyclotron frequency of a superconductor,

$$\omega_c := \frac{2eH}{m^*c}, \quad (6.118)$$

we obtain

$$\left(-\frac{\hbar^2}{2m^*} \nabla^2 - i\hbar\omega_c x \frac{\partial}{\partial y} + \frac{1}{2}m^*\omega_c^2 x^2 \right) \psi(\mathbf{r}) = \underbrace{-\alpha}_{>0} \psi(\mathbf{r}). \quad (6.119)$$

This equation has the same form as the Schrödinger equation for a particle of mass m^* and charge $q = -2e$ in a uniform magnetic field H . This well-known problem is solved by the ansatz

$$\psi(x, y) = e^{ik_y y} f(x). \quad (6.120)$$

We obtain

$$\begin{aligned} & e^{-ik_y y} \left(-\frac{\hbar^2}{2m^*} \nabla^2 - i\hbar\omega_c x \frac{\partial}{\partial y} + \frac{1}{2}m^*\omega_c^2 x^2 \right) e^{ik_y y} f(x) \\ &= -\frac{\hbar^2}{2m^*} \frac{d^2 f}{dx^2} + \frac{\hbar^2 k_y^2}{2m^*} f - i\hbar\omega_c x ik_y f + \frac{1}{2}m^*\omega_c^2 x^2 f \\ &= -\frac{\hbar^2}{2m^*} \frac{d^2 f}{dx^2} + \frac{1}{2}m^*\omega_c^2 \left(x^2 + 2\frac{\hbar k_y}{m^*\omega_c} + \frac{\hbar^2 k_y^2}{(m^*)^2 \omega_c^2} \right) f = -\alpha f. \end{aligned} \quad (6.121)$$

Defining $x_0 := -\hbar k_y / m^* \omega_c$, we get

$$-\frac{\hbar^2}{2m^*} \frac{d^2 f}{dx^2} + \frac{1}{2}m^*\omega_c^2 (x - x_0)^2 f = -\alpha f. \quad (6.122)$$

This is the Schrödinger equation for a one-dimensional harmonic oscillator with shifted minimum. Thus we obtain solutions $f_n(x)$ as shifted harmonic-oscillator eigenfunctions for

$$-\alpha = \hbar\omega_c \left(n + \frac{1}{2} \right), \quad n = 0, 1, 2, \dots \quad (6.123)$$

For at least one solution to exist, we need

$$-\alpha = -\alpha'(T - T_c) = \alpha'(T_c - T) \geq \frac{\hbar\omega_c}{2} = \frac{\hbar e H}{m^* c}. \quad (6.124)$$

Keeping $T \leq T_c$ fixed, a solution can thus only exist for $H \leq H_{c2}$ with the upper critical field

$$H_{c2} = -\frac{m^* c}{\hbar e} \alpha. \quad (6.125)$$

Using $\xi^2 = -\hbar^2/2m^*\alpha$, we obtain

$$H_{c2}(T) = \frac{\hbar c}{2e \xi^2(T)} = \frac{\Phi_0}{2\pi \xi^2(T)}. \quad (6.126)$$

Note that since $\xi \sim 1/\sqrt{T_c - T}$ close to T_c , $H_{c2}(T)$ sets in linearly, as shown in the above sketch.

H_{c2} should be compared to the thermodynamic critical field H_c ,

$$\begin{aligned} H_c^2 &= -\frac{mc^2}{2e^2} \frac{1}{\lambda^2} \alpha = \frac{\hbar^2 c^2}{8e^2} \frac{1}{\lambda^2 \xi^2} = \frac{1}{8\pi^2} \left(\frac{\hbar c}{2e} \right)^2 \frac{1}{\lambda^2 \xi^2} \\ \Rightarrow H_c &= \frac{\Phi_0}{2\pi\sqrt{2}\lambda\xi} = \frac{H_{c2}\xi}{\sqrt{2}\lambda} = \frac{H_{c2}}{\sqrt{2}\kappa} \\ \Rightarrow H_{c2} &= \sqrt{2}\kappa H_c. \end{aligned} \quad (6.127)$$

For $\kappa = 1/\sqrt{2}$, H_{c2} equals H_c . This is the transition between a type-II and a type-I superconductor.

So far, our considerations have not told us what the state for $H \lesssim H_{c2}$ actually looks like. To find out, one in principle has to solve the full, not the linearized, Ginzburg-Landau equation. (We have seen that the linearized equation is equivalent to the Schrödinger equation for a particle in a uniform magnetic field. The solutions are known: The eigenfunctions have uniform amplitude and the eigenenergies form discrete Landau levels, very different from what is observed in the Shubnikov phase.) Abrikosov did this approximately using a variational approach. He used linear combinations of solutions of the linearized equation as the variational ansatz and *assumed* that the solution is periodic in two dimensions, up to a plane wave.

We call the periods in the x - and y -directions a_x and a_y , respectively. The function

$$\psi_n(x, y) = e^{ik_y y} f_n(x) \quad (6.128)$$

has the period a_y in y if

$$k_y = \frac{2\pi}{a_y} q, \quad q \in \mathbb{Z}. \quad (6.129)$$

Then the harmonic oscillator is centered at

$$x_0 = -\frac{\hbar}{m^* \omega_c} \frac{2\pi}{a_y} q = -\frac{\Phi_0}{H a_y} q. \quad (6.130)$$

Since the lowest-energy solution is obtained for $n = 0$ (the ground state of the harmonic oscillator) Abrikosov only considered the $n = 0$ solutions

$$\psi_0(x, y) = \exp\left(iq \frac{2\pi y}{a_y}\right) f_0(x) = \underbrace{C}_{\text{normalization}} \exp\left(iq \frac{2\pi y}{a_y}\right) \exp\left(-\frac{1}{2} \frac{m^* \omega_c}{\hbar} \left[\underbrace{x + \frac{\Phi_0}{H a_y} q}_{-x_0} \right]^2\right). \quad (6.131)$$

In the Gauss function we find the quantity

$$\frac{\hbar}{m^*\omega_c} = \frac{\hbar c}{2eH} \approx \frac{\hbar c}{2eH_{c2}} = -\frac{\hbar^2}{2m^*\alpha} = \xi^2(T), \quad (6.132)$$

as long as $H \approx H_{c2}$. Thus

$$\psi_0(x, y) = C \exp\left(iq \frac{2\pi y}{a_y}\right) \exp\left(-\frac{1}{2\xi^2} \left[x + \frac{\Phi_0}{Ha_y} q\right]^2\right). \quad (6.133)$$

This is a set of functions enumerated by $q \in \mathbb{Z}$. Abrikosov considered linear combinations

$$\psi(x, y) = \sum_{q=-\infty}^{\infty} C_q \exp\left(iq \frac{2\pi y}{a_y}\right) \exp\left(-\frac{1}{2\xi^2} \left[x + \frac{\Phi_0}{Ha_y} q\right]^2\right). \quad (6.134)$$

To be periodic in x with period a_x , up to a plane wave (the corresponding discussion in Tinkham's book is not fully correct), this ansatz has to satisfy

$$\begin{aligned} \psi(x + a_x, y) &= \sum_{q=-\infty}^{\infty} C_q \exp\left(iq \frac{2\pi y}{a_y}\right) \exp\left(-\frac{1}{2\xi^2} \left[x + a_x + \frac{\Phi_0}{Ha_y} q\right]^2\right) \\ &= \sum_{q=-\infty}^{\infty} C_q \exp\left(iq \frac{2\pi y}{a_y}\right) \exp\left(-\frac{1}{2\xi^2} \left[x + \frac{\Phi_0}{Ha_y} \left(q + \frac{Ha_x a_y}{\Phi_0}\right)\right]^2\right) \\ &\stackrel{!}{\propto} \psi(x, y) \quad \forall x, y. \end{aligned} \quad (6.135)$$

This requires

$$\frac{Ha_x a_y}{\Phi_0} =: \nu \in \mathbb{N}. \quad (6.136)$$

(Note that this quantity is positive.) Then

$$\begin{aligned} \psi(x + a_x, y) &= \sum_{q=-\infty}^{\infty} C_q \exp\left(iq \frac{2\pi y}{a_y}\right) \exp\left(-\frac{1}{2\xi^2} \left[x + \frac{\Phi_0}{Ha_y} (q + \nu)\right]^2\right) \\ &= \exp\left(i\nu \frac{2\pi y}{a_y}\right) \sum_{q=-\infty}^{\infty} C_{q-\nu} \exp\left(iq \frac{2\pi y}{a_y}\right) \exp\left(-\frac{1}{2\xi^2} \left[x + \frac{\Phi_0}{Ha_y} q\right]^2\right). \end{aligned} \quad (6.137)$$

This equals $\psi(x, y)$ up to a plane-wave factor if

$$C_{q-\nu} = C_q \quad \forall q, \quad (6.138)$$

i.e., if C_q is periodic. Abrikosov considered the case $\nu = 1$, which leads to a square lattice. The lowest-free-energy solution is obtained for $\nu = 2$ and $C_1 = iC_0$, which gives a triangular lattice, sketched above. Note that

$$\nu = \frac{Ha_x a_y}{\Phi_0} \quad (6.139)$$

has a simple interpretation: It is the number of flux quanta passing through a rectangular unit cell of the vortex lattice.

The vortex lattice is a rather complex system: It is a lattice of interacting lines with a line tension ϵ_v . At nonzero temperatures, the vortices fluctuate, which can lead to the *melting* of the vortex lattice. The resulting *vortex liquid* can be pictured as a pot of boiling spaghetti, with the constraint that the vortex lines must either terminate at the surface or form closed loops (!). Moving vortices lead to ohmic resistance, even though most of the sample is still superconducting. Moreover, the interaction of vortices with defects ("pinning") plays an important role. There is an extensive research literature on vortex matter, which we cannot review here.

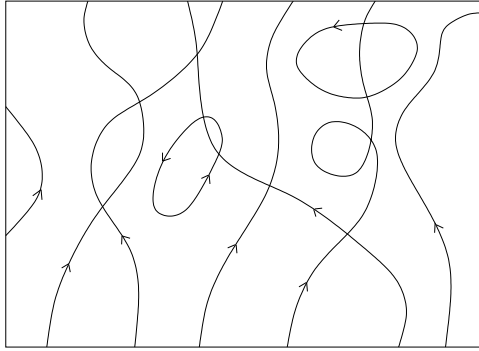

↑ **H**

7

Superfluid and superconducting films

Generally, fluctuations are stronger in systems of lower dimension. Indeed, they change the key properties of two-dimensional superfluid and superconducting films qualitatively compared to three-dimensional samples. We will consider such films within the Ginzburg-Landau theory.

7.1 Superfluid films

We start from the two-dimensional Landau functional

$$F[\psi] = \int d^2r \left[\alpha |\psi|^2 + \frac{\beta}{2} |\psi|^4 + \gamma (\nabla\psi)^* \cdot \nabla\psi \right]. \quad (7.1)$$

We consider temperatures $T < T_c$. As shown in Sec. 6.2, fluctuations of the amplitude $|\psi|$ then have an energy gap, whereas fluctuations of the phase ϕ are ungapped. Not too close to T_c , phase fluctuations will thus dominate and we neglect amplitude fluctuations, writing

$$\psi(\mathbf{r}) = \psi_0 e^{i\phi(\mathbf{r})} \quad \text{with} \quad \psi_0 = \sqrt{-\alpha/\beta}. \quad (7.2)$$

Thus, up to an irrelevant constant,

$$F[\phi] = \int d^2r \underbrace{\left(-\gamma \frac{\alpha}{\beta} \right)}_{>0} (\nabla\phi)^* \cdot \nabla\phi = \sum_{\mathbf{k}} \left(-\gamma \frac{\alpha}{\beta} \right) k^2 \phi_{\mathbf{k}}^* \phi_{\mathbf{k}}. \quad (7.3)$$

We can now calculate the correlation function

$$\langle \psi(\mathbf{r})^* \psi(0) \rangle = \psi_0^2 \langle e^{-i\phi(\mathbf{r})} e^{i\phi(0)} \rangle \equiv \psi_0^2 \frac{1}{\mathcal{Z}} \int D\phi e^{-i\phi(\mathbf{r}) + i\phi(0)} e^{-F[\phi]/k_B T}. \quad (7.4)$$

This is a Gaussian average since $F[\phi]$ is bilinear in $\phi_{\mathbf{k}}$. We now expand the exponential in the average into a Taylor series,

$$\langle \psi(\mathbf{r})^* \psi(0) \rangle = \psi_0^2 \sum_{n=0}^{\infty} \frac{1}{n!} (-i)^n \langle (\phi(\mathbf{r}) - \phi(0))^n \rangle. \quad (7.5)$$

Making use of known properties of Gaussian averages, we write this as

$$\begin{aligned} \langle \psi(\mathbf{r})^* \psi(0) \rangle &= \psi_0^2 \sum_{\substack{n=0 \\ n \text{ even}}}^{\infty} \frac{1}{n!} (-i)^n 1 \times 3 \times 5 \times \dots \times (n-1) \langle (\phi(\mathbf{r}) - \phi(0))^2 \rangle^{n/2} \\ &\equiv \psi_0^2 \sum_{m=0}^{\infty} (-1)^m \frac{1 \times 3 \times 5 \times \dots \times (2m-1)}{1 \times 2 \times 3 \times \dots \times (2m)} \langle (\phi(\mathbf{r}) - \phi(0))^2 \rangle^m \end{aligned}$$

$$\begin{aligned}
&= \psi_0^2 \sum_{m=0}^{\infty} (-1)^m \underbrace{\frac{1}{2 \times 4 \times \dots \times (2m)}}_{= \frac{1}{2^m m!}} \langle (\phi(\mathbf{r}) - \phi(0))^2 \rangle^m \\
&= \psi_0^2 \sum_{m=0}^{\infty} \frac{1}{m!} \left(-\frac{1}{2} \right)^m \langle (\phi(\mathbf{r}) - \phi(0))^2 \rangle^m \\
&= \psi_0^2 \exp \left(-\frac{1}{2} \langle (\phi(\mathbf{r}) - \phi(0))^2 \rangle \right). \tag{7.6}
\end{aligned}$$

Herein, we have, with the system area A ,

$$\begin{aligned}
\langle (\phi(\mathbf{r}) - \phi(0))^2 \rangle &= \langle (\phi(\mathbf{r}) - \phi(0))^* (\phi(\mathbf{r}) - \phi(0)) \rangle \\
&= \frac{1}{A} \sum_{\mathbf{k}\mathbf{k}'} (e^{-i\mathbf{k}\cdot\mathbf{r}} - 1)(e^{i\mathbf{k}'\cdot\mathbf{r}} - 1) \langle \phi_{\mathbf{k}}^* \phi_{\mathbf{k}'} \rangle \\
&= \frac{1}{A} \frac{1}{2} \sum_{\mathbf{k}\mathbf{k}'} (e^{-i\mathbf{k}\cdot\mathbf{r}} - 1)(e^{i\mathbf{k}'\cdot\mathbf{r}} - 1) \delta_{\mathbf{k}\mathbf{k}'} \frac{k_B T \beta}{-\gamma \alpha} \frac{1}{k^2} \quad \left| \text{from Eq. (7.3)} \right. \\
&= \frac{1}{A} \frac{1}{2} \sum_{\mathbf{k}} (2 - 2 \cos \mathbf{k} \cdot \mathbf{r}) \frac{k_B T \beta}{-\gamma \alpha} \frac{1}{k^2}. \tag{7.7}
\end{aligned}$$

The factor of $1/2$ appearing in the third line is somewhat subtle. It stems from $\phi(\mathbf{r})$ being a real field so that the integrals over $\phi_{\mathbf{k}}$ and $\phi_{\mathbf{k}}^*$ double count the physical degrees of freedom. Going over to the thermodynamic limit, i.e., the continuum description, we obtain

$$\begin{aligned}
\langle (\phi(\mathbf{r}) - \phi(0))^2 \rangle &= \frac{k_B T \beta}{-\gamma \alpha} \int \frac{d^2 k}{(2\pi)^2} \frac{1 - \cos \mathbf{k} \cdot \mathbf{r}}{k^2} \\
&= \frac{k_B T \beta}{-\gamma \alpha} \frac{1}{(2\pi)^2} \int_0^{2\pi} d\varphi \int_0^{\Lambda} dk \frac{1 - \cos(kr \cos \varphi)}{k} \\
&= \frac{k_B T \beta}{-\gamma \alpha} \frac{1}{2\pi} \int_0^{\Lambda} dk \frac{1}{k} [1 - \underbrace{J_0(kr)}_{\text{Bessel function}}]. \tag{7.8}
\end{aligned}$$

The k -integral is cut off at Λ , which is the inverse of some microscopic length scale, $\Lambda = 1/r_0$. The idea is that contributions from shorter length scales $r < r_0$ have been integrated out to obtain the Landau functional. The substitution $u = kr$ gives

$$\langle (\phi(\mathbf{r}) - \phi(0))^2 \rangle = \frac{k_B T \beta}{-\gamma \alpha} \frac{1}{2\pi} \int_0^{r/r_0} du \frac{1 - J_0(u)}{u} = \frac{k_B T \beta}{-\gamma \alpha} \frac{1}{2\pi} \frac{(r/r_0)^2}{8} {}_2F_3 \left(1, 1; 2, 2, 2; -\frac{(r/r_0)^2}{4} \right). \tag{7.9}$$

The resulting expression contains a generalized hypergeometric function. However, for large $r/r_0 \gg 1$, there exists a simple expansion:

$$\langle (\phi(\mathbf{r}) - \phi(0))^2 \rangle = \frac{k_B T \beta}{-\gamma \alpha} \frac{1}{2\pi} \left[\ln \frac{r}{r_0} - \ln 2 + \gamma_E + \mathcal{O} \left(\frac{r}{r_0} \right)^{-3/2} \right] \cong \frac{k_B T \beta}{-\gamma \alpha} \frac{1}{2\pi} \ln \frac{r}{r_0} \tag{7.10}$$

and thus

$$\langle \psi(\mathbf{r})^* \psi(0) \rangle \cong \psi_0^2 \exp \left(\frac{1}{2} \frac{k_B T \beta}{\gamma \alpha} \frac{1}{2\pi} \ln \frac{r}{r_0} \right) = \psi_0^2 \left(\frac{r}{r_0} \right)^{-\eta} \tag{7.11}$$

with

$$\eta = -\frac{1}{4\pi} \frac{k_B T \beta}{\gamma \alpha} > 0. \tag{7.12}$$

Thus the correlation function of the order parameters decays like a *power law* of distance in two dimensions. We do not find long-range order, which would imply $\lim_{r \rightarrow \infty} \langle \psi(\mathbf{r})^* \psi(0) \rangle \neq 0$. This result agrees with the Mermin-Wagner theorem, which forbids long-range order for the two-dimensional superfluid. The power-law decay characterizes so-called *quasi-long-range order* (short range order would have an even faster, e.g., exponential, decay).

Isolated vortices

We have argued that fluctuations in the amplitude are less important because they have an energy gap proportional to $-2\alpha > 0$. This is indeed true for *small* amplitude fluctuations. However, there exist variations of the amplitude that are, while energetically costly, very stable once they have been created. These are vortices. In two dimensions, a vortex is a zero-dimensional object; the order parameter goes to zero at a single point at its center. The simplest form of a vortex at the origin can be represented by

$$\psi(\mathbf{r}) = |\psi(\mathbf{r})| e^{i\phi(\mathbf{r})} = |\psi(r)| e^{i(\varphi - \varphi_0)}, \quad (7.13)$$

where r and φ are (planar) polar coordinates of \mathbf{r} . An *antivortex* would be described by

$$\psi(\mathbf{r}) = |\psi(r)| e^{-i(\varphi - \varphi_0)}. \quad (7.14)$$

In both cases, $\lim_{r \rightarrow 0} |\psi(r)| = 0$. Note that we have changed the convention for the sign in the exponent compared to superconducting vortices.

In the presence of vortices, the phase $\phi(\mathbf{r})$ of the order parameter is multivalued. Moreover, it is of course undefined at the vortex centers. On the other hand, the phase gradient $\mathbf{v} = \nabla\phi$ is single-valued (but still undefined at the vortex centers). For any closed loop \mathcal{C} not touching any vortex cores, we have

$$\oint_{\mathcal{C}} ds \cdot \mathbf{v} = \text{total change in phase along } \mathcal{C} = 2\pi N_{\mathcal{C}}, \quad (7.15)$$

where $N_{\mathcal{C}} \in \mathbb{Z}$ is the enclosed *winding number* or *vorticity*. It is a topological invariant of the vortices since it cannot be changed by a continuous deformation of $\psi(\mathbf{r})$ unless ψ is made zero somewhere on the loop \mathcal{C} . Like in three dimensions, vortices are topological defects of the condensate.

The vorticity can be written as the sum of the vorticities $N_i = \pm 1$ of all vortices and antivortices inside the loop,

$$N_{\mathcal{C}} = \sum_i N_i. \quad (7.16)$$

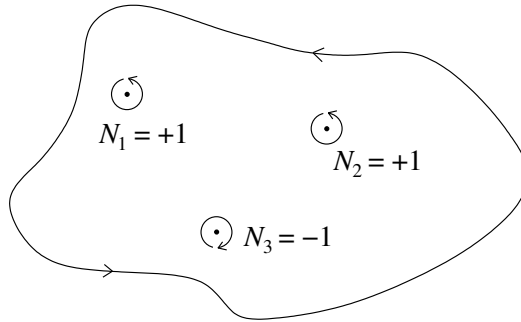

We now evaluate

$$\nabla \times \mathbf{v} = \frac{\partial}{\partial x} v_y - \frac{\partial}{\partial y} v_x = \frac{\partial}{\partial x} \frac{\partial \phi}{\partial y} - \frac{\partial}{\partial y} \frac{\partial \phi}{\partial x}. \quad (7.17)$$

Note that in two dimensions the curl is a scalar. We assume \mathbf{v} to be differentiable where it exists. Then $\nabla \times \mathbf{v}$ vanishes where \mathbf{v} exists since the derivative commute. However, \mathbf{v} does not exist at vortex cores. $\nabla \times \mathbf{v}$ can be extended to these points in the sense of distributions. For a single vortex at the origin, we make the ansatz

$$\nabla \times \mathbf{v} = c \delta(\mathbf{r}) \quad (7.18)$$

with c an unknown constant and integrate over an area \mathcal{S} that contains the vortex core

$$c = \iint_{\mathcal{S}} d^2r c \delta(\mathbf{r}) = \iint_{\mathcal{S}} d^2r \nabla \times \mathbf{v} \stackrel{\text{Stokes}}{=} \oint_{\partial\mathcal{S}} d\mathbf{s} \cdot \mathbf{v} = 2\pi. \quad (7.19)$$

Hence for a single vortex we find

$$\nabla \times \mathbf{v} = 2\pi \delta(\mathbf{r}). \quad (7.20)$$

Generalization to multiple vortices at positions \mathbf{R}_i gives

$$\nabla \times \mathbf{v} = 2\pi \sum_i N_i \delta(\mathbf{r} - \mathbf{R}_i) = 2\pi n_v(\mathbf{r}), \quad (7.21)$$

where we have used the vortex concentration

$$n_v(\mathbf{r}) := \sum_i N_i \delta(\mathbf{r} - \mathbf{R}_i). \quad (7.22)$$

Now it is always possible to decompose a vector field into a curl-free (irrotational) and a divergence-free component,

$$\mathbf{v} = \mathbf{v}_{\text{ph}} + \mathbf{v}_v, \quad (7.23)$$

with

$$\nabla \times \mathbf{v}_{\text{ph}} = 0, \quad (7.24)$$

$$\nabla \cdot \mathbf{v}_v = 0. \quad (7.25)$$

Since the curl of and thus the vortex concentration associated with \mathbf{v}_{ph} vanishes, the component \mathbf{v}_{ph} does not contain any vortices. Alternatively, note that the first equation implies that there exists a *single-valued* scalar field $\Omega(\mathbf{r})$ so that

$$\mathbf{v}_{\text{ph}} = \nabla\Omega. \quad (7.26)$$

Ω is a single-valued component of the phase, which cannot be due to vortices. This is the contribution from small phase fluctuations, which we have already discussed. It leads to quasi-long-range order etc.

Conversely, \mathbf{v}_v is the vortex part, for which

$$\nabla \times \mathbf{v}_v = 2\pi n_v, \quad (7.27)$$

$$\nabla \cdot \mathbf{v}_v = 0. \quad (7.28)$$

These relations suggest an electrostatic analogy. It is advantageous to rescale and rotate the field \mathbf{v}_v :

$$\mathbf{E}(\mathbf{r}) := -\underbrace{\sqrt{-8\pi\gamma \frac{\alpha}{\beta}}}_{>0} \hat{\mathbf{z}} \times \mathbf{v}_v(\mathbf{r}). \quad (7.29)$$

Then the energy density far from vortex cores, where $|\psi| \cong \sqrt{-\alpha/\beta}$, is

$$w = -\gamma \frac{\alpha}{\beta} (\nabla\phi_v) \cdot \nabla\phi_v = -\gamma \frac{\alpha}{\beta} \mathbf{v}_v \cdot \mathbf{v}_v = -\gamma \frac{\alpha}{\beta} \left(-8\pi\gamma \frac{\alpha}{\beta}\right)^{-1} \mathbf{E} \cdot \mathbf{E} = \frac{1}{8\pi} \mathbf{E} \cdot \mathbf{E}. \quad (7.30)$$

Also, we find

$$\nabla \cdot \mathbf{E} = -\sqrt{-8\pi\gamma \frac{\alpha}{\beta}} (-\nabla \times \mathbf{v}_v) = 2\pi \sqrt{-8\pi\gamma \frac{\alpha}{\beta}} n_v \quad (7.31)$$

and

$$\nabla \times \mathbf{E} = 0. \quad (7.32)$$

These equations reproduce the fundamental equations of electrostatics if we identify the charge density with

$$\rho_v = \sqrt{-8\pi\gamma \frac{\alpha}{\beta}} n_v. \quad (7.33)$$

The factor in Gauss' law $\nabla \cdot \mathbf{E} = 2\pi\rho_v$ is 2π instead of 4π since we are considering a two-dimensional system. We can now derive the pseudo-electric field $\mathbf{E}(\mathbf{r})$ for a single vortex,

$$\oint d\mathbf{a} \cdot \mathbf{E} = 2\pi r E = 2\pi \sqrt{-8\pi\gamma \frac{\alpha}{\beta}} \quad (7.34)$$

$$\Rightarrow E(\mathbf{r}) = \frac{\sqrt{-8\pi\gamma \frac{\alpha}{\beta}}}{r} \quad (7.35)$$

and thus

$$\mathbf{E}(\mathbf{r}) = \frac{\sqrt{-8\pi\gamma \frac{\alpha}{\beta}}}{r} \hat{\mathbf{r}}. \quad (7.36)$$

From this, we obtain the energy of a single vortex,

$$E_1 = E_{\text{core}} + \int d^2r \frac{1}{8\pi} \mathbf{E} \cdot \mathbf{E} = E_{\text{core}} - \frac{1}{8\pi} 8\pi\gamma \frac{\alpha}{\beta} \int d^2r \frac{1}{r^2} = E_{\text{core}} - 2\pi\gamma \frac{\alpha}{\beta} \int dr \frac{1}{r}. \quad (7.37)$$

Now we note that the derivation does not hold for small distances from the vortex center since there $|\psi|^2$ is not close to $-\alpha/\beta$. Thus we cut off the radial integral at the lower end at some *vortex core radius* r_0 and put all energy contributions from the core into E_{core} . r_0 is on the order of the coherence length ξ since this is the length scale on which $|\psi|$ changes. But the integral still diverges at the upper limit; if our system has a characteristic size of L , we obtain

$$E_1 = E_{\text{core}} - 2\pi\gamma \frac{\alpha}{\beta} \int_{r_0}^L \frac{dr}{r} = E_{\text{core}} - \underbrace{2\pi\gamma \frac{\alpha}{\beta}}_{>0} \ln \frac{L}{r_0}. \quad (7.38)$$

Thus the energy of a single, isolated vortex diverges logarithmically with the system size. This suggests that isolated vortices will never be present as thermal fluctuations as long as $\alpha < 0$. This is not true, though. The probability density or average concentration of such vortices should be

$$\begin{aligned} p_1 &\propto \frac{1}{r_0^2} e^{-E_1/k_B T} = \frac{1}{r_0^2} e^{-E_{\text{core}}/k_B T} \exp\left(\frac{2\pi}{k_B T} \gamma \frac{\alpha}{\beta} \ln \frac{L}{r_0}\right) \\ &= \frac{1}{r_0^2} e^{-E_{\text{core}}/k_B T} \left(\frac{L}{r_0}\right)^{\frac{2\pi}{k_B T} \gamma \frac{\alpha}{\beta}} = \frac{1}{r_0^2} e^{-E_{\text{core}}/k_B T} \left(\frac{L}{r_0}\right)^{-1/2\eta}. \end{aligned} \quad (7.39)$$

The total number of vortices is, on average,

$$N_v = L^2 p_1 \propto e^{-E_{\text{core}}/k_B T} \left(\frac{L}{r_0}\right)^{2-1/2\eta}. \quad (7.40)$$

For $\eta > 1/4$, N_v diverges in the thermodynamic limit so that infinitely many vortices are present. For $\eta < 1/4$, $N_v \rightarrow 0$ for $L \rightarrow \infty$ and according to our argument, which is essentially due to Kosterlitz and Thouless, there are no vortices. It is plausible and indeed true that free vortices destroy quasi-long-range order and in this sense also superfluidity. Note that

$$\eta = -\frac{1}{4\pi} \frac{k_B T \beta}{\gamma \alpha(T)} \stackrel{!}{=} \frac{1}{4} \quad (7.41)$$

is an equation for a critical temperature for the appearance of free vortices. We thus find that the critical temperature in superfluid films should be reduced from the point where $\alpha = 0$ ($\eta \rightarrow \infty$) to the one where $\eta = 1/4$ due to vortices appearing as fluctuations of the order parameter. While qualitatively true, our description is still incomplete, though, since we have so far neglected interactions between vortices.

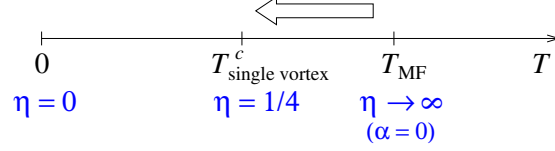

Vortex interaction

The energy of two vortices with vorticities ± 1 can easily be obtained from the electrostatic analogy. We assume that core regions do not overlap, i.e., the separation is $R \geq 2r_0$. The pseudo-electric field of the two vortices, assumed to be located at $\pm \mathbf{R}/2 = \pm R \hat{\mathbf{x}}/2$, is

$$\begin{aligned} \mathbf{E}(\mathbf{r}) &= \sqrt{-8\pi\gamma \frac{\alpha}{\beta}} \frac{\mathbf{r} - \mathbf{R}/2}{|\mathbf{r} - \mathbf{R}/2|^2} - \sqrt{-8\pi\gamma \frac{\alpha}{\beta}} \frac{\mathbf{r} + \mathbf{R}/2}{|\mathbf{r} + \mathbf{R}/2|^2} \\ &= \sqrt{-8\pi\gamma \frac{\alpha}{\beta}} \frac{|\mathbf{r} + \mathbf{R}/2|^2 (\mathbf{r} - \mathbf{R}/2) - |\mathbf{r} - \mathbf{R}/2|^2 (\mathbf{r} + \mathbf{R}/2)}{|\mathbf{r} - \mathbf{R}/2|^2 |\mathbf{r} + \mathbf{R}/2|^2}. \end{aligned} \quad (7.42)$$

Thus the energy is

$$\begin{aligned} E_2 &= 2E_{\text{core}} + \int d^2r \frac{1}{8\pi} \mathbf{E} \cdot \mathbf{E} \\ &= 2E_{\text{core}} - \frac{1}{8\pi} 8\pi\gamma \frac{\alpha}{\beta} \int d^2r \left(\frac{|\mathbf{r} + \mathbf{R}/2|^2 (\mathbf{r} - \mathbf{R}/2) - |\mathbf{r} - \mathbf{R}/2|^2 (\mathbf{r} + \mathbf{R}/2)}{|\mathbf{r} - \mathbf{R}/2|^2 |\mathbf{r} + \mathbf{R}/2|^2} \right)^2 \\ &= 2E_{\text{core}} - \gamma \frac{\alpha}{\beta} 2 \int_{-\infty}^{\infty} dx \int_0^{\infty} dy \\ &\quad \times \frac{|\mathbf{r} + \mathbf{R}/2|^4 |\mathbf{r} - \mathbf{R}/2|^2 + |\mathbf{r} - \mathbf{R}/2|^4 |\mathbf{r} + \mathbf{R}/2|^2 - 2 |\mathbf{r} + \mathbf{R}/2|^2 |\mathbf{r} - \mathbf{R}/2|^2 (r^2 - R^2/4)}{|\mathbf{r} - \mathbf{R}/2|^4 |\mathbf{r} + \mathbf{R}/2|^4}. \end{aligned} \quad (7.43)$$

We introduce elliptic coordinates σ, τ according to

$$x = \frac{R}{2} \sigma \tau, \quad (7.44)$$

$$y = \frac{R}{2} \sqrt{\sigma^2 - 1} \sqrt{1 - \tau^2}, \quad (7.45)$$

where $\sigma \in [1, \infty[$, $\tau \in [-1, 1]$. Then

$$\begin{aligned} E_2 &= 2E_{\text{core}} - 2\gamma \frac{\alpha}{\beta} \left(\frac{R}{2} \right)^2 \int d\sigma d\tau \frac{\sigma^2 - \tau^2}{\sqrt{\sigma^2 - 1} \sqrt{1 - \tau^2}} \\ &\quad \times \frac{\left(\frac{R}{2} \right)^4 (\sigma + \tau)^4 \left(\frac{R}{2} \right)^2 (\sigma - \tau)^2 + \left(\frac{R}{2} \right)^4 (\sigma - \tau)^4 \left(\frac{R}{2} \right)^2 (\sigma + \tau)^2}{\left(\frac{R}{2} \right)^4 (\sigma - \tau)^4 \left(\frac{R}{2} \right)^4 (\sigma + \tau)^4} \\ &\quad - \frac{2 \left(\frac{R}{2} \right)^2 (\sigma + \tau)^2 \left(\frac{R}{2} \right)^2 (\sigma - \tau)^2 \left(\frac{R}{2} \right)^2 (\sigma^2 \tau^2 + (\sigma^2 - 1)(1 - \tau^2) - 1)}{\left(\frac{R}{2} \right)^4 (\sigma - \tau)^4 \left(\frac{R}{2} \right)^4 (\sigma + \tau)^4} \\ &= 2E_{\text{core}} - 2\gamma \frac{\alpha}{\beta} \int d\sigma d\tau \frac{1}{\sqrt{\sigma^2 - 1} \sqrt{1 - \tau^2}} \frac{(\sigma + \tau)^2 + (\sigma - \tau)^2 - 2(\sigma^2 + \tau^2 - 2)}{\sigma^2 - \tau^2} \\ &= 2E_{\text{core}} - 2\gamma \frac{\alpha}{\beta} \int d\sigma d\tau \frac{1}{\sqrt{\sigma^2 - 1} \sqrt{1 - \tau^2}} \frac{4}{\sigma^2 - \tau^2} \\ &= 2E_{\text{core}} - 8\pi\gamma \frac{\alpha}{\beta} \int d\sigma \frac{1}{\sigma(\sigma^2 - 1)}. \end{aligned} \quad (7.46)$$

We have to keep in mind that the integrals in real space have a lower cutoff r_0 . The minimum separation from the vortex at $R\hat{\mathbf{x}}/2$ is $(\sigma - 1)R/2$. For this separation to equal r_0 , the lower cutoff for σ must be

$$\sigma_0 = 1 + \frac{2r_0}{R}. \quad (7.47)$$

With this cutoff, we obtain

$$E_2 = 2E_{\text{core}} - 8\pi\gamma \frac{\alpha}{\beta} \frac{1}{2} \ln \frac{(R + 2r_0)^2}{4r_0(R + r_0)}, \quad (7.48)$$

which for $R \gg r_0$ becomes

$$E_2 = 2E_{\text{core}} - 4\pi\gamma \frac{\alpha}{\beta} \ln \frac{R}{4r_0}. \quad (7.49)$$

We absorb an R -independent constant into E_{core} and finally obtain

$$E_2 \equiv 2E_{\text{core}} + V_{\text{int}}(R) = 2E_{\text{core}} - \underbrace{4\pi\gamma \frac{\alpha}{\beta}}_{>0} \ln \frac{R}{r_0}. \quad (7.50)$$

Note that the energy of a vortex-antivortex pair is independent of the system size L . Also, the vortex-antivortex interaction $V_{\text{int}}(R)$ increases with R , i.e., vortex and antivortex *attract* each other. Conversely, one can show that vortices with the same vorticity repel each other.

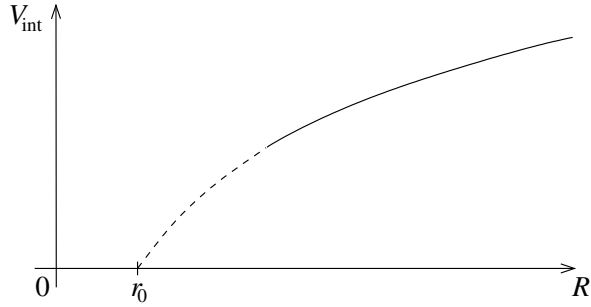

One can also show that for arbitrary vorticities $N_1, N_2 \in \mathbb{Z}$, the interaction reads

$$V_{\text{int}}(R) = \underbrace{4\pi\gamma \frac{\alpha}{\beta}}_{<0} N_1 N_2 \ln \frac{R}{r_0}. \quad (7.51)$$

Since the equations of (pseudo-) electrostatics are linear, the superposition principle applies and we do not have additional 3-, 4-, etc. body interactions. The energy of a system of vortices is thus

$$E = \sum_i E_{\text{core}} + \frac{1}{2} \sum_{ij, i \neq j} N_i N_j v_{\text{int}}(|\mathbf{r}_i - \mathbf{r}_j|) \quad (7.52)$$

with

$$v_{\text{int}}(r) := 4\pi\gamma \frac{\alpha}{\beta} \ln \frac{r}{r_0}, \quad (7.53)$$

provided that $\sum_i N_i = 0$. If the total vorticity $\sum_i N_i$ does not vanish, the energy diverges logarithmically with the system size, as we have seen. As long as the total vorticity is zero, the energy per vortex is finite and thus we expect a non-zero concentration of vortices for all temperatures $T > 0$. We now want to understand the consequences of their presence.

Berezinskii-Kosterlitz-Thouless theory

The vortices in a two-dimensional superfluid behave like a *Coulomb gas*—a gas of charged particles with Coulomb interaction, which is logarithmic in 2D. We consider the case that the (perhaps suitably modified) exponent η is smaller than $1/4$ so that the total vorticity (charge) has to vanish. It is then possible to group the vortices into *vortex-antivortex pairs*. We do this using the following simple algorithm:

1. find the vortex and the antivortex with the smallest separation r ,
2. mark this vortex and this antivortex as a pair,
3. repeat these steps for all remaining vortices until none are left.

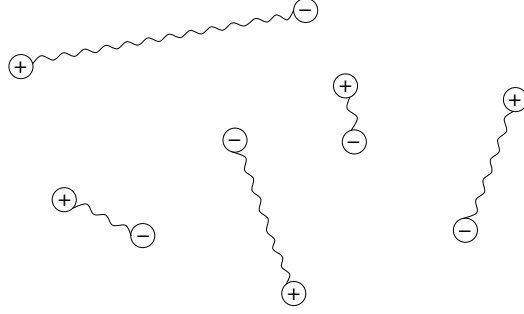

The energy of an isolated vortex-antivortex pair (we will use the term “*vortex pair*” from now on) of size r is

$$E_2(r) = 2E_{\text{core}} - 4\pi\gamma \frac{\alpha}{\beta} \ln \frac{r}{r_0}. \quad (7.54)$$

Thus the probability density of such pairs is

$$p_2(r) \propto \frac{1}{r_0^4} e^{-E_2(r)/k_B T}. \quad (7.55)$$

We can then write

$$p_2(r) = \frac{1}{r_0^4} y_0^2 \exp\left(-2\pi K_0 \ln \frac{r}{r_0}\right) = \frac{1}{r_0^4} y_0^2 \left(\frac{r_0}{r}\right)^{2\pi K_0}. \quad (7.56)$$

Here,

$$y_0 := N_0 e^{-E_{\text{core}}/k_B T} \quad (7.57)$$

is called the vortex *fugacity*. N_0 is a constant of order unity; N_0^2 is the constant of proportionality implied in Eq. (7.55). More precisely, y_0^2 is a vortex-pair fugacity. Furthermore,

$$K_0 := -\frac{1}{k_B T} 2\gamma \frac{\alpha}{\beta} > 0 \quad (7.58)$$

is a dimensionless measure for the interaction strength in units of the thermal energy. K_0 is the *stiffness* of the condensate against phase fluctuations. Note that the previously defined exponent η is related to K_0 through $\eta = 1/(2\pi K_0)$.

The crucial idea is now that smaller pairs are *polarized* in the pseudo-electric field of the vortex and antivortex forming a given pair. This leads to the *screening* of the vortex-antivortex interaction and thus reduces the energy of large pairs. Formally, this can be described by renormalization-group (RG) theory (Kosterlitz 1974), which we will summarize in the following. The grand-canonical partition function of the vortex-antivortex system is

$$\mathcal{Z}_0 = \sum_N \frac{1}{(N!)^2} y_0^{2N} \int_{D_1} \frac{d^2 r_1}{r_0^2} \cdots \int_{D_{2N}} \frac{d^2 r_{2N}}{r_0^2} \exp\left(\frac{1}{2} \sum_{i \neq j} 2\pi N_i N_j K_0 \ln \frac{|\mathbf{r}_i - \mathbf{r}_j|}{r_0}\right), \quad (7.59)$$

where we have already implemented the constraint that the number of vortices, N , equals the number of antivortices. The ranges of integration, D_i , comprise the two-dimensional space \mathbb{R}^2 excluding disks of radius r_0 centered at all vortices (and antivortices) with numbers $j < i$. This means that the minimum separation is r_0 . The idea of RG theory is to perform the integrals for the smallest pairs of sizes between r_0 and $r_0 + dr$ and rewrite the result (approximately) in a form identical to \mathcal{Z}_0 but with changed (“renormalized”) parameters. Physically, we thereby omit the smallest pairs and take their effects into account by renormalizing the parameters.

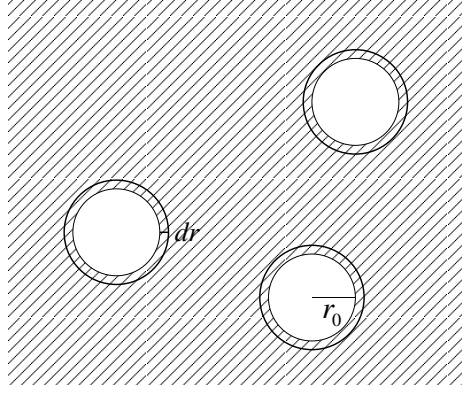

In this way, the partition function, the fugacity, and the stiffness become functions of the smallest length scale, which we now denote by r . These “running” quantities are written as \mathcal{Z} , y , and K , respectively. Thus

$$\mathcal{Z} = \sum_N \frac{1}{(N!)^2} y^{2N} \int_{D_1} \frac{d^2 r_1}{r^2} \cdots \int_{D_{2N}} \frac{d^2 r_{2N}}{r^2} \exp \left(\frac{1}{2} \sum_{i \neq j} 2\pi N_i N_j K \ln \frac{|\mathbf{r}_i - \mathbf{r}_j|}{r} \right). \quad (7.60)$$

We now perform the integrals over the smallest separations between r and $r' = r + dr$. A crucial assumption is that this only involves vortex-antivortex pairs, not pairs of equal vorticity. This is plausible since a vortex and an antivortex attract each other. The integration starts by splitting the integrals,

$$\begin{aligned} \int_{D_1} d^2 r_1 \cdots \int_{D_{2N}} d^2 r_{2N} &\cong \int_{D'_1} d^2 r_1 \cdots \int_{D'_{2N}} d^2 r_{2N} \\ &+ \frac{1}{2} \sum_{i \neq j} \delta_{N_i, -N_j} \underbrace{\int_{D'_1} d^2 r_1 \cdots \int_{D'_{2N}} d^2 r_{2N}}_{\text{excluding } i, j} \int_{\tilde{D}_{i,j}} d^2 r_j \int_{r \leq |\mathbf{r}_i - \mathbf{r}_j| < r+dr} d^2 r_i. \end{aligned} \quad (7.61)$$

The D'_i correspond to the D_i but with the minimum separation increased to $r + dr$. $\tilde{D}_{i,j}$ is the full \mathbb{R}^2 excluding disks of radius r around all vortices $n \neq i, j$. Inserting this into the expression for \mathcal{Z} , we obtain the integral, from the second term,

$$\begin{aligned} &\int_{\tilde{D}_{i,j}} d^2 r_j \int_{r \leq |\mathbf{r}_i - \mathbf{r}_j| < r+dr} d^2 r_i \exp \left(2\pi \sum_{n \neq i, j} N_n N_j K \ln \frac{|\mathbf{r}_n - \mathbf{r}_j|}{r} \right. \\ &\quad \left. - 2\pi \sum_{n \neq i, j} N_n N_j K \ln \frac{|\mathbf{r}_n - \mathbf{r}_i|}{r} - 2\pi K \ln \frac{|\mathbf{r}_j - \mathbf{r}_i|}{r} \right) \\ &\cong \int_{\tilde{D}_{i,j}} d^2 r_j 2\pi r dr \left(1 + \pi^2 K^2 \sum_{m, n \neq i, j} N_m N_n \frac{(\mathbf{r}_m - \mathbf{r}_j) \cdot (\mathbf{r}_n - \mathbf{r}_j) r^2}{|\mathbf{r}_m - \mathbf{r}_j|^2 |\mathbf{r}_n - \mathbf{r}_j|^2} \right) \end{aligned}$$

$$= 2\pi r dr \left(A + \pi^2 K^2 \sum_{m,n \neq i,j} N_m N_n r^2 \int_{\tilde{D}_{i,j}} d^2 r_j \frac{(\mathbf{r}_m - \mathbf{r}_j) \cdot (\mathbf{r}_n - \mathbf{r}_j)}{|\mathbf{r}_m - \mathbf{r}_j|^2 |\mathbf{r}_n - \mathbf{r}_j|^2} \right), \quad (7.62)$$

where A is the area of the system. Herein, we have

$$\int_{\tilde{D}_{i,j}} d^2 r_j \frac{(\mathbf{r}_m - \mathbf{r}_j) \cdot (\mathbf{r}_n - \mathbf{r}_j)}{|\mathbf{r}_m - \mathbf{r}_j|^2 |\mathbf{r}_n - \mathbf{r}_j|^2} = 2\pi \ln \frac{L}{r} - 2\pi (1 - \delta_{mn}) \ln \frac{|\mathbf{r}_m - \mathbf{r}_n|}{r}. \quad (7.63)$$

The first term diverges for $L \rightarrow \infty$ but drops out when the sum over m, n is performed, due to overall vanishing vorticity. The result is

$$\dots = 2\pi r dr \left(A - 2\pi^3 K^2 r^2 \sum_{\substack{m,n \neq i,j \\ m \neq n}} N_m N_n \ln \frac{|\mathbf{r}_m - \mathbf{r}_n|}{r} \right) \quad (7.64)$$

and with the sum over i, j :

$$\frac{1}{2} \sum_{i \neq j} \dots = 2\pi r dr \left(N^2 A - 2\pi^3 K^2 r^2 \sum_{m \neq n} (N-1)^2 N_m N_n \ln \frac{|\mathbf{r}_m - \mathbf{r}_n|}{r} \right), \quad (7.65)$$

neglecting some terms of order N^0 . Inserting everything into \mathcal{Z} , we obtain two terms: The first corresponds to \mathcal{Z} with D_i replaced by D'_i and the second reads

$$\begin{aligned} & \sum_N \frac{1}{(N!)^2} \left(\frac{y}{r^2} \right)^{2N} \underbrace{\int_{D'_1} d^2 r_1 \dots \int_{D'_{2N}} d^2 r_{2N}}_{2N-2 \text{ integrals}} 2\pi r dr \\ & \times \left(N^2 A - 2\pi^3 K^2 r^2 \sum_{m \neq n} (N-1)^2 N_m N_n \ln \frac{|\mathbf{r}_m - \mathbf{r}_n|}{r} \right) \exp \left(\underbrace{\frac{1}{2} 2\pi K \sum_{i \neq j} N_i N_j \ln \frac{|\mathbf{r}_m - \mathbf{r}_n|}{r}}_{(2N-2)(2N-3) \text{ terms}} \right). \end{aligned} \quad (7.66)$$

We rename the summation index N as $N+1$ in this second term. Then both terms contain $2N$ integrals under the sum over N . We also put all terms containing dr into the exponent using $1 + a dr = e^{a dr}$. We obtain

$$\begin{aligned} \mathcal{Z}' &= \exp \left(2\pi \left(\frac{y}{r^2} \right)^2 r dr A \right) \sum_N \frac{1}{(N!)^2} \left(\frac{y}{r^2} \right)^{2N} \int_{D'_1} d^2 r_1 \dots \int_{D'_{2N}} d^2 r_{2N} \\ & \times \exp \left[-\frac{1}{2} \sum_{i \neq j} \left(-2\pi K + 8\pi^4 y^2 K^2 \frac{dr}{r} \right) N_i N_j \ln \frac{|\mathbf{r}_i - \mathbf{r}_j|}{r} \right]. \end{aligned} \quad (7.67)$$

Next, we have to express \mathcal{Z}' in terms of the new length scale $r' := r + dr$. This is only relevant in expressions not already linear in dr . This applies to, on the one hand,

$$\frac{1}{r^2} = \frac{1}{(r' - dr)^2} = \frac{1 + 2 \frac{dr}{r'}}{(r')^2}, \quad (7.68)$$

and, on the other,

$$\exp \left(-\frac{1}{2} \sum_{i \neq j} 2\pi K N_i N_j \ln r \right) = \exp \left(-\frac{1}{2} \sum_{i \neq j} 2\pi K N_i N_j \ln(r' - dr) \right)$$

$$\begin{aligned}
&= \exp \left(-\frac{1}{2} \sum_{i \neq j} 2\pi K N_i N_j \ln r' \right) \exp \left(\frac{1}{2} \sum_{i \neq j} 2\pi K N_i N_j \frac{dr}{r'} \right) \\
&= \exp \left(-\frac{1}{2} \sum_{i \neq j} 2\pi K N_i N_j \ln r' \right) \left(1 - \pi K \frac{dr}{r'} \right)^{2N}, \tag{7.69}
\end{aligned}$$

neglecting terms of order N^0 compared to N . The renormalized partition function is finally

$$\begin{aligned}
\mathcal{Z}' &= \exp \left[\underbrace{2\pi \left(\frac{y}{(r')^2} \right)^2 r' dr A}_{=: \mathcal{Z}_{\text{pair}}} \right] \sum_N \frac{1}{(N!)^2} \left(\frac{y}{(r')^2} \right)^{2N} \left[1 + (2 - \pi K) \frac{dr}{r'} \right]^{2N} \\
&\times \int_{D'_1} d^2 r_1 \cdots \int_{D'_{2N}} d^2 r_{2N} \exp \left[\frac{1}{2} \sum_{i \neq j} \left(2\pi K - 8\pi^4 y^2 K^2 \frac{dr}{r'} \right) N_i N_j \ln \frac{|\mathbf{r}_i - \mathbf{r}_j|}{r'} \right]. \tag{7.70}
\end{aligned}$$

Here, $\mathcal{Z}_{\text{pair}}$ is the partition function of the small pair we have integrated out. It is irrelevant for the renormalization of y and K . Apart from this factor, \mathcal{Z}' is identical to \mathcal{Z} if we set

$$y(r') \equiv y(r + dr) = \left[1 + (2 - \pi K(r)) \frac{dr}{r'} \right] y(r) \tag{7.71}$$

$$K(r') \equiv K(r + dr) = K(r) - 4\pi^3 y^2(r) K^2(r) \frac{dr}{r'}. \tag{7.72}$$

On the right-hand sides, we can replace dr/r' by dr/r since the difference is of second order in dr :

$$y(r') \equiv y(r + dr) = \left[1 + (2 - \pi K(r)) \frac{dr}{r} \right] y(r) \tag{7.73}$$

$$K(r') \equiv K(r + dr) = K(r) - 4\pi^3 y^2(r) K^2(r) \frac{dr}{r}. \tag{7.74}$$

Introducing the logarithmic length scale

$$l := \ln \frac{r}{r_0} \quad \Rightarrow \quad dl = \frac{dr}{r}, \tag{7.75}$$

we obtain the Kosterlitz RG *flow equations*

$$\frac{dy}{dl} = (2 - \pi K) y, \tag{7.76}$$

$$\frac{dK}{dl} = -4\pi^3 y^2 K^2. \tag{7.77}$$

The initial conditions are

$$y(l = 0) = y_0 = e^{-E_{\text{core}}/k_B T}, \tag{7.78}$$

$$K(l = 0) = K_0 = -\frac{1}{k_B T} 2\gamma \frac{\alpha(T)}{\beta}, \tag{7.79}$$

i.e., the parameters assume their “bare” values at $r = r_0$ ($l = 0$).

We will now discuss the physics encoded by the RG flow equations. First, note that the quantity

$$C := 2\pi^2 y^2 - \frac{2}{\pi K} - \ln K \tag{7.80}$$

is invariant under the RG flow:

$$\frac{dC}{dl} = 4\pi^2 y \frac{dy}{dl} - \frac{2}{\pi K^2} \frac{dK}{dl} - \frac{1}{K} \frac{dK}{dl} = 4\pi^2 y^2 (2 - \pi K) - 8\pi^2 y^2 + 4\pi^3 y^2 K = 0. \quad (7.81)$$

Thus C is a “first integral” of the flow equations. We can calculate C from the initial values y_0, K_0 and obtain

$$2\pi^2 y^2 = 2\pi^2 y_0^2 + \frac{2}{\pi} \left(\frac{1}{K} - \frac{1}{K_0} \right) + \ln \frac{K}{K_0} \quad (7.82)$$

$$\Rightarrow y = \sqrt{y_0^2 + \frac{1}{\pi^3} \left(\frac{1}{K} - \frac{1}{K_0} \right) + \frac{1}{2\pi^2} \ln \frac{K}{K_0}}. \quad (7.83)$$

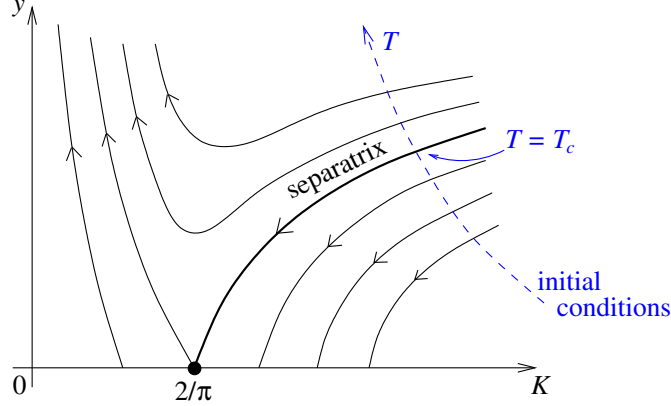

The RG flow is along curves described by this expression, where the curves are specified by y_0, K_0 . The direction of the flow is towards smaller K since $dK/dl < 0$. The parameters y_0, K_0 change with temperature as given in Eqs. (7.78) and (7.79). These initial conditions are sketched as a dashed line in the figure. We see that there are two distinct cases:

- For $T < T_c$, K flows to some finite value $K(l \rightarrow \infty) > 2/\pi$. This means that even infinitely large pairs feel a logarithmic attraction, i.e., are bound. Moreover, the fugacity y flows to zero, $y(l \rightarrow \infty) = 0$. Thus large pairs are very rare, which is consistent with their (logarithmically) diverging energy.
- For $T > T_c$, K flows to $K(l \rightarrow \infty) = 0$. Thus the interaction between a vortex and an antivortex that are far apart is completely screened. Large pairs become unbound. Also, y diverges on large length scales, which means that these unbound vortices proliferate. This divergence is an artifact of keeping only the leading order in y in the derivation. It is cut off at finite y if we count (in particular, large) vortex-antivortex pairs consistently. But the limit $K \rightarrow 0$ remains valid.

At $T = T_c$ we thus find a phase transition at which vortex-antivortex pairs unbind, forming free vortices. It is called the *Berezinskii-Kosterlitz-Thouless (BKT) transition*. In two-dimensional films, vortex interactions thus suppress the temperature where free vortices appear and quasi-long-range order is lost from the point $T = T_{\text{single vortex}}^c$ where

$$\eta = -\frac{1}{4\pi} \frac{k_B T \beta}{\gamma \alpha} = \frac{1}{2\pi} \frac{1}{K_0} \stackrel{!}{=} \frac{1}{4} \Rightarrow K_0 = \frac{2}{\pi} \quad (7.84)$$

to the one where $K(l \rightarrow \infty) = 2/\pi$ and y_0, K_0 lie on the “separatrix” between the two phases,

$$C = 2\pi^2 y_0^2 - \frac{2}{\pi K_0} - \ln K_0 \stackrel{!}{=} 2\pi^2 y^2(l \rightarrow \infty) - \frac{2}{\pi K(l \rightarrow \infty)} - \ln K(l \rightarrow \infty) = 0 - 1 - \ln \frac{2}{\pi} \quad (7.85)$$

$$\Rightarrow \frac{2}{\pi K_0} + \ln K_0 = 1 + \ln \frac{2}{\pi} + 2\pi^2 y_0^2. \quad (7.86)$$

Clearly the two criteria agree if $y_0 = 0$. This makes sense since for $y_0 = 0$ there are no vortex pairs to screen the interaction. In addition, a third temperature scale is given by the mean-field transition temperature T_{MF} , where $\alpha = 0$.

$$\begin{aligned}
&\cong -1 + \cancel{\frac{\pi}{2}\Delta K} - \frac{\pi^2}{4}\Delta K^2 - \ln \frac{2}{\pi} - \cancel{\frac{\pi}{2}\Delta K} + \frac{1}{2}\frac{\pi^2}{4}\Delta K^2 \\
&= -1 - \ln \frac{2}{\pi} - \frac{\pi^2}{8}\Delta K^2.
\end{aligned} \tag{7.95}$$

Thus

$$-\frac{\pi^2}{8}\Delta K^2 \cong b(T - T_c) \Rightarrow \Delta K \cong \underbrace{\frac{2}{\pi}\sqrt{2b}}_{\text{const}}\sqrt{T_c - T}. \tag{7.96}$$

Consequently, $n_s = (K/K_0)n_s^0$ jumps to a finite value at T_c and then increases like a square root.

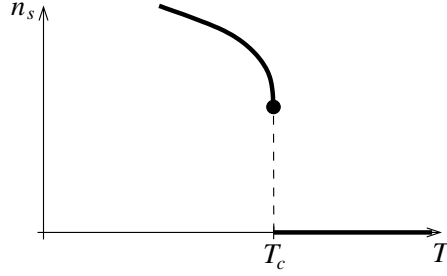

This behavior was indeed measured in torsion-pendulum experiments on He-4 films (Bishop and Reppy, 1980).

7.2 Superconducting films

In this section we concentrate on what is different for charged superconductors compared to neutral superfluids. Recall that for a superfluid the gradient term in the Landau functional reads

$$\int d^2r \gamma (\nabla\psi)^* \cdot \nabla\psi. \tag{7.97}$$

If we move around a vortex once, the phase has to change by 2π , regardless of the distance from the vortex core. This phase change leads to an unavoidable contribution to the gradient term of

$$\begin{aligned}
\int d^2r \gamma (\nabla\psi)^* \cdot \nabla\psi &\cong -\gamma \frac{\alpha}{\beta} \int dr d\varphi r \left(\frac{1}{r} \frac{\partial}{\partial\varphi} e^{i\phi} \right)^* \frac{1}{r} \frac{\partial}{\partial\varphi} e^{i\phi} \\
&= -\gamma \frac{\alpha}{\beta} \int dr d\varphi \frac{1}{r} \left(\frac{\partial\phi}{\partial\varphi} \right)^2 = -\gamma \frac{\alpha}{\beta} \int dr d\varphi \frac{1}{r} = -2\pi\gamma \frac{\alpha}{\beta} \int \frac{dr}{r},
\end{aligned} \tag{7.98}$$

which diverges logarithmically with system size. On the other hand, for a superconducting film the gradient term reads

$$\int d^2r \frac{1}{2m^*} \left| \left(\frac{\hbar}{i} \nabla - \frac{q}{c} \mathbf{A} \right) \psi \right|^2. \tag{7.99}$$

Again, the phase of ψ winds by 2π around a vortex, but the associated gradient can, in principle, be compensated by the vector potential. Pearl (1964) showed that this indeed leads to a *finite* energy of a single vortex in a superconducting film. In addition, the free energy contains the magnetic-field term

$$\int d^3r \frac{B^2(\mathbf{r})}{8\pi}. \tag{7.100}$$

Note that the integral is *three dimensional*—the field is present in all of space, also outside of the film.

We first note that the film has a new length scale: In the London gauge, Ampère's law reads

$$\nabla \times (\nabla \times \mathbf{A}) = \underbrace{\nabla(\nabla \cdot \mathbf{A})}_{=0} - \nabla^2 \mathbf{A} = \frac{4\pi}{c} \mathbf{j} \Rightarrow \nabla^2 \mathbf{A} = -\frac{4\pi}{c} \mathbf{j}. \tag{7.101}$$

On the other hand, from the London equation we have

$$\mathbf{j} = -\frac{c}{4\pi\lambda^2} \mathbf{A}, \quad (7.102)$$

which is valid within the film and away from vortex cores so that $|\psi|^2 \cong -\alpha/\beta$. However, the current is confined to the thin film. We can write

$$\mathbf{j}(\mathbf{r}) = \mathbf{K}(x, y) \delta(z) \quad (7.103)$$

with a surface current density \mathbf{K} . Thus

$$\mathbf{K}(x, y) = \int_{-\infty}^{\infty} dz \mathbf{j}(\mathbf{r}) = \int_{\text{film}} dz \left(-\frac{c}{4\pi\lambda^2} \right) \mathbf{A}(\mathbf{r}). \quad (7.104)$$

If the thickness is d and \mathbf{A} is approximately constant across the thickness, we have

$$\mathbf{K}(x, y) = -\frac{c}{4\pi} \frac{d}{\lambda^2} \mathbf{A}(x, y, 0) \quad (7.105)$$

$$\Rightarrow \mathbf{j}(\mathbf{r}) = -\frac{c}{4\pi} \frac{d}{\lambda^2} \mathbf{A}(\mathbf{r}) \delta(z) \quad (7.106)$$

and finally

$$\nabla^2 \mathbf{A} = \frac{d}{\lambda^2} \mathbf{A} \delta(z). \quad (7.107)$$

This result exhibits the new length scale that controls the spatial variation of \mathbf{A} and thus of the current \mathbf{j} ,

$$\lambda_{\perp} := \frac{\lambda^2}{d}, \quad (7.108)$$

which is large, $\lambda_{\perp} \gg \lambda$, for a thin film. We see that in thin films, λ_{\perp} assumes the role of the penetration depth λ . Since λ_{\perp} is large for thin films, one could say that thin films are always effectively of type II.

We here do not discuss the full derivation of Pearl but only consider the “far field” for large $r \gg \lambda_{\perp}$ and show that it does not lead to a diverging free energy for a single vortex. We assume that most of the magnetic flux of Φ_0 penetrates the film for $\varrho = \sqrt{x^2 + y^2} \lesssim \lambda_{\perp}$. Then the magnetic field above (and below) the film looks like a monopole field for $r \gg \lambda_{\perp}$.

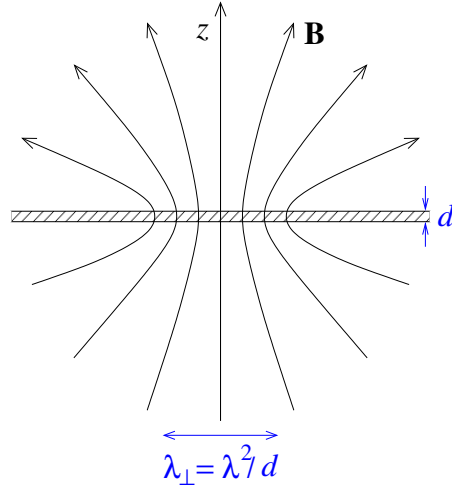

This field is easy to obtain from symmetry:

$$\int_{\text{half space for } z>0} d\mathbf{a} \cdot \mathbf{B} = \Phi_0 \quad \Rightarrow \quad 2\pi r^2 B = \Phi_0 \quad (7.109)$$

$$\Rightarrow B(r) = \frac{\Phi_0}{2\pi r^2} \quad \text{and} \quad \mathbf{B}(\mathbf{r}) = \frac{\Phi_0}{2\pi r^2} \hat{\mathbf{r}} \quad \text{for } z > 0. \quad (7.110)$$

By symmetry,

$$\mathbf{B}(\mathbf{r}) = \text{sgn } z \frac{\Phi_0}{2\pi r^2} \hat{\mathbf{r}}. \quad (7.111)$$

This gives a contribution to the field energy of

$$\int d^3r \frac{B^2}{8\pi} = \frac{\Phi_0^2}{32\pi^3} \int d^3r \frac{1}{r^4} = \frac{\Phi_0^2}{32\pi^3} 4\pi \int_{\lambda_\perp}^{\infty} \frac{dr}{r^2} = \frac{\Phi_0^2}{8\pi^2} \frac{1}{\lambda_\perp}, \quad (7.112)$$

which is finite for an infinite film. The value of the lower cutoff does not matter for this. The cutoff has to be present since the monopole field is not a valid approximation for small r .

We next obtain the current from Ampère's law in integral form:

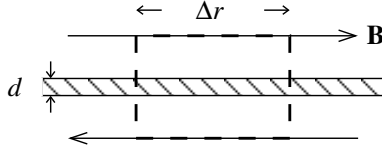

$$\oint d\mathbf{x} \cdot \mathbf{B} = \frac{4\pi}{c} \int d\mathbf{a} \cdot \mathbf{j} \quad (7.113)$$

$$\Rightarrow 2 \int_r^{r+\Delta r} dr' \frac{\Phi_0}{2\pi(r')^2} = \frac{4\pi}{c} \Delta r d j(r) \quad (7.114)$$

$$\Rightarrow \frac{4\pi}{c} \Delta r d j(r) = \frac{\Phi_0}{\pi} \left(\frac{1}{r} - \frac{1}{r+\Delta r} \right) \cong \frac{\Phi_0}{\pi} \frac{\Delta r}{r^2} \quad (7.115)$$

$$\Rightarrow j(r) = \frac{\Phi_0}{4\pi^2} \frac{1}{r^2 d} \quad (7.116)$$

and with the vector character restored

$$\mathbf{j}(\mathbf{r}) = \frac{\Phi_0}{4\pi^2} \frac{\hat{\phi}}{r^2 d}. \quad (7.117)$$

Note that the sheet current is thus

$$\mathbf{K}(\mathbf{r}) = \frac{\Phi_0}{4\pi^2} \frac{\hat{\phi}}{r^2}. \quad (7.118)$$

For large r we have $|\psi| = \psi_0 = \sqrt{-\alpha/\beta}$ (note that typically $\lambda_\perp \gg \xi$). Then the second Ginzburg-Landau equation gives

$$\mathbf{j} = i \frac{q\hbar}{2m^*} (-i\nabla\phi - i\nabla\phi)\psi_0^2 - \frac{q^2}{m^*c} \psi_0^2 \mathbf{A} = \psi_0^2 \frac{q}{m^*} \left(\hbar\nabla\phi - \frac{q}{c} \mathbf{A} \right). \quad (7.119)$$

Thus we can rewrite the gradient term in the free energy as

$$d \int d^2r \frac{1}{2m^*} \psi_0^2 \left(\hbar\nabla\phi - \frac{q}{c} \mathbf{A} \right)^2 = d \int d^2r \frac{\psi_0^2 (m^*)^2}{2m^* \psi_0^4 q^2} \mathbf{j} \cdot \mathbf{j} = d \int d^2r \frac{m^*}{2q^2 \psi_0^2} \mathbf{j} \cdot \mathbf{j}. \quad (7.120)$$

The contribution from large r is

$$\frac{dm^*}{2q^2 \psi_0^2} \int d^2r \frac{\Phi_0^2}{16\pi^4} \frac{1}{r^4 d^2} = \frac{m^* \Phi_0^2}{32\pi^4 q^2 \psi_0^2 d} 2\pi \int_{\lambda_\perp}^{\infty} \frac{dr}{r^3} = \frac{m^* \Phi_0^2}{8\pi^3 q^2 \psi_0^2 d} \frac{1}{\lambda_\perp}, \quad (7.121)$$

which is also finite for an infinite film.

We conclude that the free energy of an isolated vortex is finite in a superconducting film. It is then plausible and indeed true that the interaction energy of a vortex-antivortex pair does not diverge for large separations r but saturates for $r \gg \lambda_{\perp}$. Since for the far field of a single vortex the magnetic-field energy, Eq. (7.112), dominates over the energy due to the gradient term, we expect the large- r interaction to be dominated by the Coulomb-type attraction of the magnetic monopoles in the upper and lower half spaces. This supposition is borne out by a proper analysis. Consequently, for large r the interaction behaves like

$$V_{\text{int}}(r) \cong \text{const} - \left(\frac{\Phi_0}{2\pi}\right)^2 \frac{1}{r}, \quad (7.122)$$

where $\Phi_0/2\pi$ is the monopole strength, according to Eq. (7.111).

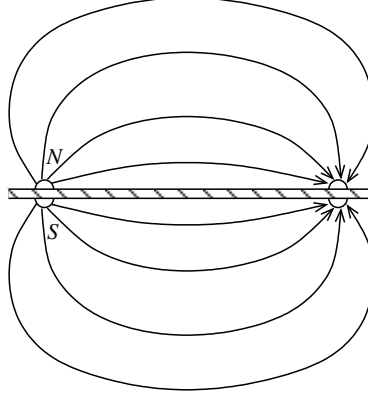

All this shows that, strictly speaking, there will be a non-zero concentration of free vortices at any temperature $T > 0$. Thus there is no quasi-long-range order. However, the relevant length scale is $\lambda_{\perp} = \lambda^2/d$, which can be very large for thin films, even compared to the size L of the sample. In this case, the large- r limit is experimentally irrelevant. But for vortex separations $r \ll \lambda_{\perp}$, the magnetic-field expulsion on the scale r is very weak since λ_{\perp} is the effective penetration depth. Then the fact that the condensate is charged is irrelevant and we obtain the same logarithmic interaction as for a neutral superfluid.

Thus for thin films of typical size we can use the previously discussed BKT theory. For superconducting films we even have the advantage of an additional observable, namely the *voltage* for given current. We now give a hand-waving derivation of $V(I)$. The idea is that a current exerts a *Magnus force* on a vortex, in the direction perpendicular to the current. The force is opposite for vortices and antivortices and is thus able to break vortex-antivortex pairs. As noted above, free vortices lead to dissipation. A vortex moving through the sample in the orthogonal direction between source and drain contacts leads to a change of the phase difference $\Delta\phi$ by $\pm 2\pi$. We will see in the chapter on Josephson effects why this corresponds to a non-zero voltage. Since free vortices act independently, it is plausible to assume that the resistance is

$$R \propto n_v, \quad (7.123)$$

where n_v now denotes the concentration of free vortices. To find it, note that the total potential energy due to vortex-antivortex attraction and Magnus force can be written as

$$V = V_{\text{int}} - 2F_{\text{Magnus}} r, \quad (7.124)$$

with (we assume $r \ll \lambda_{\perp}$)

$$V_{\text{int}} = 2\pi k_B T K \ln \frac{r}{r_0}. \quad (7.125)$$

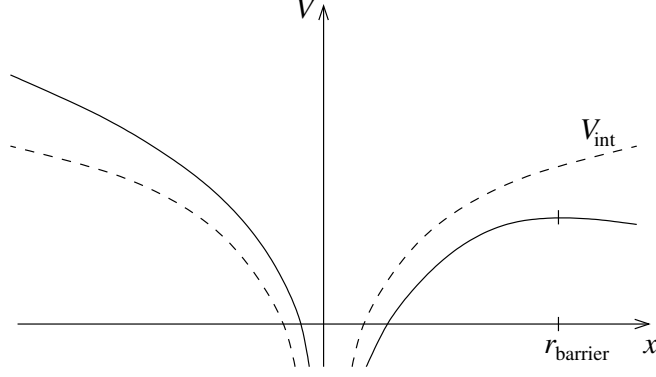

There is a finite barrier for vortex-antivortex unbinding at a separation r_{barrier} determined from $\partial V/\partial r = 0$. This gives

$$r_{\text{barrier}} = \frac{2\pi k_B T K_{\text{barrier}}}{2F_{\text{Magnus}}}, \quad (7.126)$$

where $K_{\text{barrier}} := K(r_{\text{barrier}})$. The barrier height is

$$\begin{aligned} \Delta E &:= V(r_{\text{barrier}}) - V(r_0) \cong V(r_{\text{barrier}}) \\ &= 2\pi k_B T K_{\text{barrier}} \ln \frac{r_{\text{barrier}}}{r_0} - 2F_{\text{Magnus}} r_{\text{barrier}} \\ &= 2\pi k_B T K_{\text{barrier}} \left(\ln \frac{r_{\text{barrier}}}{r_0} - 1 \right). \end{aligned} \quad (7.127)$$

For small currents we have $r_{\text{barrier}} \gg r_0$ and thus

$$\Delta E \cong 2\pi k_B T \underbrace{K(l \rightarrow \infty)}_{\equiv K} \ln \frac{r_{\text{barrier}}}{r_0}. \quad (7.128)$$

The rate at which free vortices are generated is

$$R_{\text{gen}} \propto e^{-\beta \Delta E} \cong \left(\frac{r_{\text{barrier}}}{r_0} \right)^{-2\pi K}. \quad (7.129)$$

The recombination rate of two vortices to form a pair is

$$R_{\text{rec}} \propto n_v^2, \quad (7.130)$$

since two vortices must meet. In the stationary state we have

$$R_{\text{gen}} = R_{\text{rec}} \quad \Rightarrow \quad n_v \propto \sqrt{R_{\text{gen}}} \propto \left(\frac{r_{\text{barrier}}}{r_0} \right)^{-\pi K} \quad (7.131)$$

and thus a resistance of

$$R \propto n_v \propto \left(\frac{r_{\text{barrier}}}{r_0} \right)^{-\pi K}. \quad (7.132)$$

Since the Magnus force F_{Magnus} is proportional to the current I we have

$$r_{\text{barrier}} \propto \frac{1}{F_{\text{Magnus}}} \propto \frac{1}{I} \quad (7.133)$$

so that

$$R \propto \left(\frac{1}{I} \right)^{-\pi K} = I^{\pi K}. \quad (7.134)$$

Finally, the voltage measured for a current I is

$$V = RI \propto I^{\pi K} I = I^{1+\pi K}, \quad (7.135)$$

where $K \equiv K(l \rightarrow \infty)$ is the renormalized stiffness. Since

$$K = \frac{2}{\pi} + \Delta K \cong \frac{2}{\pi} \left(1 + \sqrt{2b} \sqrt{T_c - T}\right) \quad (7.136)$$

we find for the exponent

$$1 + \pi K \cong 3 + \underbrace{2\sqrt{2b}}_{=\text{const}} \sqrt{T_c - T} \quad (7.137)$$

for $T \lesssim T_c$.

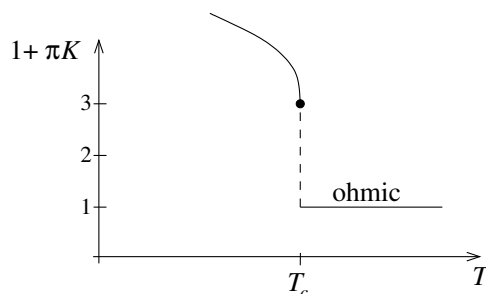

Above T_c , we have $K = 0$ and thus ohmic resistance, $V \propto I$, as expected. At T_c , the exponent jumps to the *universal* value 3, i.e., $V \propto I^3$. For $T \leq T_c$, the voltage is *sub-ohmic*, i.e., the voltage is finite for finite current but rises more slowly than linearly for small currents. This behavior has been observed for thin superconducting films. Thus they are not superconducting in the sense of ideal conduction.

8

Origin of the attractive interaction

In the following chapters we turn to the microscopic theory of superconductivity. While the BCS theory is reasonably easy to understand if one assumes an attractive interaction between electrons in a superconductor, it is far from obvious where such an interaction should come from. The only fundamental interaction that is relevant for (non-radioactive) solids is the electromagnetic one, which naively gives a *repulsive* interaction of a typical strength of several eV between nearby electrons. How can this lead to an attraction at the low energy scale $k_B T_c \sim 1$ meV? We will see that the lattice of ion cores (nuclei with tightly bound inner electrons) plays an important role, in particular its dynamics. We will use Feynman diagrams for Green functions to describe the physics. Unfortunately, we do not have the time to introduce these concepts rigorously; this is done in many good textbooks on many-particle physics as well as in the lecture notes on Many-Particle Theory (in German), which are available online. For those familiar with Feynman diagrams, they rigorously represent mathematical expressions, for the others they should at least be useful as cartoons of the relevant processes.

8.1 Reminder on Green functions

Nevertheless, we start by briefly summarizing relevant properties of Green functions. In many-particle physics, we usefully express the Hamiltonian in terms of an electronic *field operator* $\Psi_\sigma(\mathbf{r}, t)$, where $\sigma = \uparrow, \downarrow$ is the electron spin. The field operator can be expanded in any convenient basis of single-particle states characterized by wavefunctions $\varphi_{\nu\sigma}(\mathbf{r})$, where ν represents all relevant quantum numbers,

$$\Psi_\sigma(\mathbf{r}, t) = \sum_\nu \varphi_{\nu\sigma}(\mathbf{r}) c_{\nu\sigma}(t), \quad (8.1)$$

$$\Psi_\sigma^\dagger(\mathbf{r}, t) = \sum_\nu \varphi_{\nu\sigma}^*(\mathbf{r}) c_{\nu\sigma}^\dagger(t). \quad (8.2)$$

$c_{\nu\sigma}$ and $c_{\nu\sigma}^\dagger$ are annihilation and creation operators of electrons in the single-particle state, respectively. Note that we are working in the Heisenberg picture, i.e., the wavefunctions $\varphi_{\nu\sigma}(\mathbf{r})$ are independent of time, whereas the time dependence is carried by the operators.

For example, the Hamiltonian for free electrons reads

$$H = \int d^3r \sum_\sigma \Psi_\sigma^\dagger(\mathbf{r}) \frac{-\hbar^2 \nabla^2}{2m} \Psi_\sigma(\mathbf{r}). \quad (8.3)$$

In this case it is useful to expand into plane waves,

$$\begin{aligned} \Psi_\sigma(\mathbf{r}) &= \frac{1}{\sqrt{V}} \sum_{\mathbf{k}} e^{i\mathbf{k}\cdot\mathbf{r}} c_{\mathbf{k}\sigma} \\ \Rightarrow H &= \frac{1}{V} \sum_{\mathbf{k}\mathbf{k}'} \int d^3r \sum_\sigma e^{-i\mathbf{k}\cdot\mathbf{r} + i\mathbf{k}'\cdot\mathbf{r}} c_{\mathbf{k}\sigma}^\dagger \frac{\hbar^2 (k')^2}{2m} c_{\mathbf{k}'\sigma} \end{aligned} \quad (8.4)$$

$$= \sum_{\mathbf{k}\sigma} \frac{\hbar^2 k^2}{2m} c_{\mathbf{k}\sigma}^\dagger c_{\mathbf{k}\sigma}. \quad (8.5)$$

Two types of Green functions are defined as follows:

- *greater Green function:*

$$G^>(\mathbf{r}\sigma t, \mathbf{r}'\sigma' t') := -i \left\langle \Psi_\sigma(\mathbf{r}, t) \Psi_{\sigma'}^\dagger(\mathbf{r}', t') \right\rangle, \quad (8.6)$$

where $\langle \dots \rangle$ is the equilibrium average

$$\langle A \rangle = \text{Tr} A \rho_{\text{eq}} = \frac{\text{Tr} A e^{-\beta H}}{\text{Tr} e^{-\beta H}} \equiv \frac{1}{\mathcal{Z}} \text{Tr} A e^{-\beta H}, \quad (8.7)$$

where $\beta = 1/k_B T$ is the inverse temperature and H is the many-particle Hamiltonian. For non-interacting electrons at temperature $T \ll E_F/k_B$, ρ_{eq} describes the Fermi sea. $G^>$ describes the *conditional probability amplitude* for an *electron* created at point \mathbf{r}' with spin σ' at time t' to be found at point \mathbf{r} with spin σ at time t .

- *lesser Green function:*

$$G^<(\mathbf{r}\sigma t, \mathbf{r}'\sigma' t') := +i \left\langle \Psi_{\sigma'}^\dagger(\mathbf{r}', t') \Psi_\sigma(\mathbf{r}, t) \right\rangle \quad (8.8)$$

describes the propagation of a *hole* from time t to time t' .

These are not the most useful Green functions since in quantum theory propagation of an electron forward in time cannot be separated from propagation of a hole backward in time. It is also useful to distinguish between the cases $t > t'$ and $t < t'$. This is accomplished by these definitions:

- *retarded Green function:*

$$G^R(\mathbf{r}\sigma t, \mathbf{r}'\sigma' t') := -i \Theta(t - t') \left\langle \left\{ \Psi_\sigma(\mathbf{r}, t), \Psi_{\sigma'}^\dagger(\mathbf{r}', t') \right\} \right\rangle, \quad (8.9)$$

where $\{A, B\} := AB + BA$ is the anti-commutator (appropriate for fermions) and the Heaviside step function

$$\Theta(t - t') = \begin{cases} 1 & \text{for } t > t' \\ 0 & \text{for } t < t' \end{cases} \quad (8.10)$$

selects only contributions with $t > t'$ (“forward in time”).

- *advanced Green function:*

$$G^A(\mathbf{r}\sigma t, \mathbf{r}'\sigma' t') := +i \Theta(t' - t) \left\langle \left\{ \Psi_\sigma(\mathbf{r}, t), \Psi_{\sigma'}^\dagger(\mathbf{r}', t') \right\} \right\rangle, \quad (8.11)$$

this Green function analogously contains only contributions “backward in time.”

The thermal averages in the Green functions introduce operators $e^{-\beta H}$, whereas the time evolution of operators introduces time-evolution operators according to

$$A(t) = e^{iHt/\hbar} A e^{-iHt/\hbar}. \quad (8.12)$$

Specifically, we have

$$\begin{aligned} G^R(\mathbf{r}\sigma t, \mathbf{r}'\sigma' t') &= -i \Theta(t - t') \frac{1}{\mathcal{Z}} \text{Tr} e^{-\beta H} \left(e^{iHt/\hbar} \Psi_\sigma(\mathbf{r}) e^{-iH(t-t')/\hbar} \Psi_{\sigma'}^\dagger(\mathbf{r}') e^{-iHt'/\hbar} \right. \\ &\quad \left. + e^{iHt'/\hbar} \Psi_{\sigma'}^\dagger(\mathbf{r}') e^{-iH(t'-t)/\hbar} \Psi_\sigma(\mathbf{r}) e^{-iHt/\hbar} \right). \end{aligned} \quad (8.13)$$

In practice, we will want to write the Hamiltonian in the form $H = H_0 + V$ and treat V in perturbation theory. It is not surprising that this is complicated due to the presence of H in several exponential factors. However,

these factors are of a similar form, only in some the prefactor of H is imaginary and in one it is the real inverse temperature. Can one simplify calculations by making all prefactors real? This is indeed possible by formally replacing $t \rightarrow -i\tau$, $t' \rightarrow -i\tau'$, which is the main idea behind the imaginary-time formalism. We cannot discuss it here but only state a few relevant results.

It turns out to be useful to consider the *Matsubara* (or thermal) *Green function*

$$\mathcal{G}(\mathbf{r}\sigma\tau, \mathbf{r}'\sigma'\tau') := -\left\langle T_\tau \Psi_\sigma(\mathbf{r}, \tau) \Psi_\sigma^\dagger(\mathbf{r}', \tau') \right\rangle, \quad (8.14)$$

where for any operator

$$A(\tau) := e^{H\tau/\hbar} A e^{-H\tau/\hbar} \quad (8.15)$$

and T_τ is the *time-ordering directive*

$$T_\tau A(\tau) B(\tau') = \begin{cases} A(\tau) B(\tau') & \text{for } \tau > \tau', \\ \pm B(\tau') A(\tau) & \text{for } \tau < \tau', \end{cases} \quad (8.16)$$

where the upper (lower) sign holds for bosonic (fermionic) operators. For time-independent Hamiltonians, the Green function only depends on the difference $\tau - \tau'$. One can then show that the resulting Green function $\mathcal{G}(\mathbf{r}\sigma, \mathbf{r}'\sigma', \tau)$ is defined only for $\tau \in [-\hbar\beta, \hbar\beta]$ and satisfies

$$\mathcal{G}(\mathbf{r}\sigma, \mathbf{r}'\sigma', \tau + \hbar\beta) = -\mathcal{G}(\mathbf{r}\sigma, \mathbf{r}'\sigma', \tau) \quad (8.17)$$

for fermions. This implies that the Fourier transform is a discrete sum over the fermionic *Matsubara frequencies*

$$\omega_n := \frac{(2n+1)\pi}{\hbar\beta}, \quad n \in \mathbb{Z}. \quad (8.18)$$

The imaginary-time formalism is useful mainly because \mathcal{G} is easier to obtain or approximate than the other Green functions and these can be calculated from \mathcal{G} based on the following theorem: The retarded Green function $G^R(\omega)$ in Fourier space is obtained from $\mathcal{G}(i\omega_n)$ by means of replacing $i\omega_n$ by $\omega + i0^+$, where $i0^+$ is an infinitesimal positive imaginary part,

$$G^R(\omega) = \mathcal{G}(i\omega_n \rightarrow \omega + i0^+). \quad (8.19)$$

This is called “analytic continuation.” Analogously,

$$G^A(\omega) = \mathcal{G}(i\omega_n \rightarrow \omega - i0^+). \quad (8.20)$$

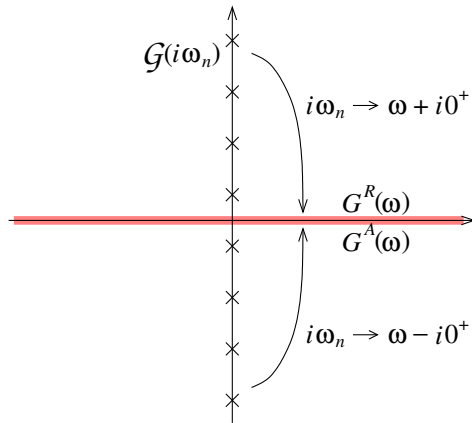

It will be useful to write the electronic Green function in \mathbf{k} space. In the cases we are interested in, momentum and also spin are conserved so that the Green function can be written as

$$\mathcal{G}_{\mathbf{k}\sigma}(\tau) = -\left\langle T_\tau c_{\mathbf{k}\sigma}(\tau) c_{\mathbf{k}\sigma}^\dagger(0) \right\rangle. \quad (8.21)$$

Analogously, the bosonic Matsubara Green function of phonons can be written as

$$\mathcal{D}_{\mathbf{q}\lambda}(\tau) = -\left\langle T_\tau b_{\mathbf{q}\lambda}(\tau) b_{\mathbf{q}\lambda}^\dagger(0) \right\rangle, \quad (8.22)$$

where λ enumerates the three polarizations of acoustic phonons. We also note that for bosons we have

$$\mathcal{D}(\tau + \hbar\beta) = +\mathcal{D}(\tau), \quad (8.23)$$

i.e., the opposite sign compared to fermions. Therefore, in the Fourier transform only the bosonic Matsubara frequencies

$$\nu_n := \frac{2\pi n}{\hbar\beta}, \quad n \in \mathbb{Z} \quad (8.24)$$

occur.

8.2 Coulomb interaction

We now discuss the effect of the electron-electron Coulomb interaction. We will mainly do that at the level of Feynman diagrams but it should be kept in mind that these represent mathematical expressions that can be evaluated as needed. The Coulomb interaction can be written in second-quantized form as

$$V_{\text{int}} = \frac{1}{2} \sum_{\sigma_1 \sigma_2} \int d^3 r_1 d^3 r_2 \Psi_{\sigma_1}^\dagger(\mathbf{r}_1) \Psi_{\sigma_2}^\dagger(\mathbf{r}_2) V_C(|\mathbf{r}_2 - \mathbf{r}_1|) \Psi_{\sigma_2}(\mathbf{r}_2) \Psi_{\sigma_1}(\mathbf{r}_1), \quad (8.25)$$

with

$$V_C(r) = \frac{e^2}{r}, \quad (8.26)$$

using Gaussian units. Glossing over potential problems related to commuting operators, this is just the Coulomb energy of a charge density $-e \sum_\sigma \Psi_\sigma^\dagger(\mathbf{r}) \Psi_\sigma(\mathbf{r})$.

In momentum space, we have

$$\Psi_\sigma(\mathbf{r}) = \frac{1}{\sqrt{V}} \sum_{\mathbf{k}} e^{i\mathbf{k}\cdot\mathbf{r}} c_{\mathbf{k}\sigma} \quad (8.27)$$

so that

$$\begin{aligned} V_{\text{int}} &= \frac{1}{2V^2} \sum_{\mathbf{k}\mathbf{k}'\mathbf{k}''\mathbf{k}'''} \sum_{\sigma_1 \sigma_2} \int d^3 r_1 d^3 r_2 e^{-i\mathbf{k}\cdot\mathbf{r}_1 - i\mathbf{k}'\cdot\mathbf{r}_2 + i\mathbf{k}''\cdot\mathbf{r}_2 + i\mathbf{k}'''\cdot\mathbf{r}_1} c_{\mathbf{k}\sigma_1}^\dagger c_{\mathbf{k}'\sigma_2}^\dagger V_C(|\mathbf{r}_2 - \mathbf{r}_1|) c_{\mathbf{k}''\sigma_2} c_{\mathbf{k}'''\sigma_1} \\ &= \frac{1}{2V^2} \sum_{\mathbf{k}\mathbf{k}'\mathbf{k}''\mathbf{k}'''} \sum_{\sigma_1 \sigma_2} \int d^3 R d^3 \rho e^{i(-\mathbf{k}-\mathbf{k}'+\mathbf{k}''+\mathbf{k}''')\cdot\mathbf{R}} e^{i(\mathbf{k}-\mathbf{k}'+\mathbf{k}''-\mathbf{k}''')\cdot\rho/2} c_{\mathbf{k}\sigma_1}^\dagger c_{\mathbf{k}'\sigma_2}^\dagger V_C(\rho) c_{\mathbf{k}''\sigma_2} c_{\mathbf{k}'''\sigma_1}, \end{aligned} \quad (8.28)$$

where

$$\mathbf{R} = \frac{\mathbf{r}_1 + \mathbf{r}_2}{2}, \quad (8.29)$$

$$\boldsymbol{\rho} = \mathbf{r}_2 - \mathbf{r}_1. \quad (8.30)$$

We can now perform the integral over \mathbf{R} :

$$\begin{aligned} V_{\text{int}} &= \frac{1}{2V} \sum_{\mathbf{k}\mathbf{k}'\mathbf{k}''\mathbf{k}'''} \sum_{\sigma_1 \sigma_2} \int d^3 \rho \delta_{\mathbf{k}+\mathbf{k}'-\mathbf{k}''-\mathbf{k}''',0} e^{i(\mathbf{k}-\mathbf{k}'+\mathbf{k}''-\mathbf{k}''')\cdot\rho/2} c_{\mathbf{k}\sigma_1}^\dagger c_{\mathbf{k}'\sigma_2}^\dagger V_C(\rho) c_{\mathbf{k}''\sigma_2} c_{\mathbf{k}'''\sigma_1} \\ &= \frac{1}{2V} \sum_{\mathbf{k}\mathbf{k}'\mathbf{k}''} \sum_{\sigma_1 \sigma_2} \int d^3 \rho e^{-i(\mathbf{k}'-\mathbf{k}'')\cdot\rho} V_C(\rho) c_{\mathbf{k}\sigma_1}^\dagger c_{\mathbf{k}'\sigma_2}^\dagger c_{\mathbf{k}''\sigma_2} c_{\mathbf{k}+\mathbf{k}'-\mathbf{k}'',\sigma_1}. \end{aligned} \quad (8.31)$$

Substituting new momentum variables

$$\mathbf{k}_1 = \mathbf{k} + \mathbf{k}' - \mathbf{k}'', \quad (8.32)$$

$$\mathbf{k}_2 = \mathbf{k}'', \quad (8.33)$$

$$\mathbf{q} = \mathbf{k}' - \mathbf{k}'', \quad (8.34)$$

we obtain

$$V_{\text{int}} = \frac{1}{2V} \sum_{\mathbf{k}_1 \mathbf{k}_2 \mathbf{q}} \sum_{\sigma_1 \sigma_2} V_C(\mathbf{q}) c_{\mathbf{k}_1 - \mathbf{q}, \sigma_1}^\dagger c_{\mathbf{k}_2 + \mathbf{q}, \sigma_2}^\dagger c_{\mathbf{k}_2 \sigma_2} c_{\mathbf{k}_1 \sigma_1} \quad (8.35)$$

with

$$V_C(\mathbf{q}) = \int d^3r e^{-i\mathbf{q}\cdot\mathbf{r}} V_C(r). \quad (8.36)$$

The interaction V_{int} is a sum over all processes in which two electrons come in with momenta \mathbf{k}_1 and \mathbf{k}_2 , a momentum of \mathbf{q} is transferred from one to the other through the Coulomb interaction, and the electrons fly out with momenta $\mathbf{k}_1 - \mathbf{q}$ and $\mathbf{k}_2 + \mathbf{q}$.

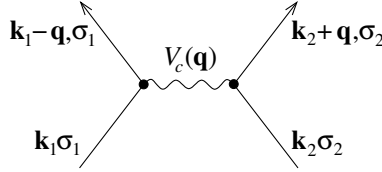

$V_C(\mathbf{q})$ is obviously the Fourier transform of the Coulomb interaction. It is most easily obtained by Fourier transforming the Poisson equation for a point charge,

$$\nabla^2 \phi(\mathbf{r}) = -4\pi \rho(\mathbf{r}) = -4\pi Q \delta(\mathbf{r}) \quad (8.37)$$

$$\Rightarrow \int d^3r e^{-i\mathbf{q}\cdot\mathbf{r}} \nabla^2 \phi(\mathbf{r}) = -4\pi Q \quad (8.38)$$

$$\stackrel{\text{by parts}}{\Rightarrow} \int d^3r (-i\mathbf{q})^2 e^{-i\mathbf{q}\cdot\mathbf{r}} \phi(\mathbf{r}) = -4\pi Q \quad (8.39)$$

$$\Rightarrow q^2 \phi(\mathbf{q}) = 4\pi Q \quad (8.40)$$

$$\Rightarrow \phi(\mathbf{q}) = 4\pi \frac{Q}{q^2} \quad (8.41)$$

so that

$$V_C(\mathbf{q}) = 4\pi \frac{e^2}{q^2}. \quad (8.42)$$

Screening and RPA

The bare Coulomb interaction V_C is strongly repulsive, as noted above. But if one (indirectly) measures the interaction between charges in a metal, one does not find V_C but a reduced interaction. First of all, there will be a dielectric function from the polarizability of the ion cores,

$$V_C(\mathbf{q}) \rightarrow \frac{4\pi}{\epsilon} \frac{e^2}{q^2}, \quad (8.43)$$

but this only leads to a quantitative change, not a qualitative one. We absorb the factor $1/\epsilon$ into e^2 from now on. More importantly, a test charge in a metal is *screened* by a cloud of opposite total charge so that from far away the effective charge is strongly reduced. Diagrammatically, the effective Coulomb interaction $V_C^{\text{full}}(\mathbf{q}, i\nu_n)$ is given by the sum of all connected diagrams with two external legs that represent the Coulomb interaction. With the representations

$$-V_C \equiv \text{~~~~~} \quad (8.44)$$

(the minus sign is conventional) and

$$-V_C^{\text{full}} \equiv \text{~~~~~} \quad (8.45)$$

as well as

$$\mathcal{G}^0 \equiv \text{---} \leftarrow \text{---} \quad (8.46)$$

for the bare electronic Green function corresponding to the non-interacting Hamiltonian H_0 , we obtain¹

$$\text{---} \text{---} \text{---} = \text{---} \text{---} \text{---} + \dots \quad (8.47)$$

This is an expansion in powers of e^2 since V_C contains a factor of e^2 . We have exhibited all diagrams up to order e^6 . If we try to evaluate this sum term by term, we encounter a problem: At each vertex \bullet , momentum and energy (frequency) must be conserved. Thus in partial diagrams of the form

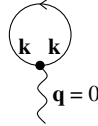

the Coulomb interaction carries momentum $\mathbf{q} = 0$. But

$$V_C(0) = 4\pi \frac{e^2}{0^2} \quad (8.48)$$

is ill defined. However, one can show that the closed \mathcal{G} loop corresponds to the average electron density so that the diagram signifies the Coulomb interaction with the average electronic charge density (i.e., the *Hartree energy*). But this is compensated by the average charge density of the nuclei. Thus we can omit all contributions containing the “tadpole” diagram shown above.

Since we still cannot evaluate the sum in closed form we need an approximation. We first consider the limiting cases of small and large \mathbf{q} in $V_C^{\text{full}}(\mathbf{q}, i\nu_n)$:

- For large \mathbf{q} , corresponding to small distances, the first diagram is proportional to $1/q^2$, whereas all the others are at least of order $1/q^4$ and are thus suppressed. We should recover the bare Coulomb interaction for large \mathbf{q} or small distances, which is plausible since the polarization of the electron gas cannot efficiently screen the interaction between two test charges that are close together.
- For small \mathbf{q} we find that higher-order terms contain higher and higher powers of $1/q^2$ and thus become larger and larger. This is alarming. The central idea of our approximation is to keep only the dominant term (diagram) at each order in e^2 . The dominant term is the one with the highest power in $1/q^2$. Only the V_C lines forming the backbone of the diagrams (drawn horizontally) carry the external momentum \mathbf{q} due to momentum conservation at the vertices. Thus the dominant terms are the ones with *all* V_C lines in the backbone:

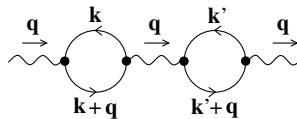

¹We do not write down the corresponding mathematical expressions here. Expressions for some of the diagrams will be derived below.

Summing up these dominant terms, we obtain the approximate effective interaction

$$\begin{aligned}
-V_C^{\text{RPA}} := & \text{~~~~~} + \text{~~~~~} \\
& + \text{~~~~~} + \text{~~~~~} \\
& + \dots
\end{aligned} \tag{8.49}$$

This is called the *random phase approximation* (RPA), for historical reasons that do not concern us here, or the Lindhard approximation. The most important part of RPA diagrams is clearly the bubble diagram

$$\Pi_0 \equiv \text{~~~~~}, \tag{8.50}$$

which stands for

$$\begin{aligned}
\Pi_0(\mathbf{q}, i\nu_n) &= -\frac{1}{\beta} \sum_{i\omega_n} \frac{1}{V} \sum_{\mathbf{k}\sigma} \mathcal{G}_{\mathbf{k}+\mathbf{q},\sigma}^0(i\omega_n + i\nu_n) \mathcal{G}_{\mathbf{k}\sigma}^0(i\omega_n) \\
&= -\frac{2}{\beta} \sum_{i\omega_n} \sum_{\mathbf{k}} \frac{1}{i\omega_n + i\nu_n - \xi_{\mathbf{k}+\mathbf{q}}} \frac{1}{i\omega_n - \xi_{\mathbf{k}}},
\end{aligned} \tag{8.51}$$

where the factor of 2 is due to the two-valued spin degree of freedom and $\xi_{\mathbf{k}} \equiv \epsilon_{\mathbf{k}} - \mu$ is the bare electronic dispersion including the chemical potential μ . Π_0 is essentially the negative of the electric susceptibility of the free electron gas. We do not show this here. It is plausible, however, that the susceptibility, which controls the electric polarization of the electron gas, should enter into a calculation of the screened Coulomb interaction.

We can write the diagrammatic series also as

$$\begin{aligned}
-V_C^{\text{RPA}}(\mathbf{q}, i\nu_n) &= -V_C(\mathbf{q}) + V_C(\mathbf{q}) \Pi_0(\mathbf{q}, i\nu_n) V_C(\mathbf{q}) - V_C(\mathbf{q}) \Pi_0(\mathbf{q}, i\nu_n) V_C(\mathbf{q}) \Pi_0(\mathbf{q}, i\nu_n) V_C(\mathbf{q}) + \dots \\
&= -V_C(\mathbf{q}) [1 - \Pi_0(\mathbf{q}, i\nu_n) V_C(\mathbf{q}) + \Pi_0(\mathbf{q}, i\nu_n) V_C(\mathbf{q}) \Pi_0(\mathbf{q}, i\nu_n) V_C(\mathbf{q}) - \dots].
\end{aligned} \tag{8.52}$$

This is a geometric series, which we can sum up, with the result

$$V_C^{\text{RPA}}(\mathbf{q}, i\nu_n) = \frac{V_C(\mathbf{q})}{1 + V_C(\mathbf{q}) \Pi_0(\mathbf{q}, i\nu_n)}. \tag{8.53}$$

Note that V_C^{RPA} has a frequency dependence since Π_0 (or the susceptibility) has one.

In the static limit $i\nu \rightarrow 0 + i0^+$ and at low temperatures $T \ll E_F/k_B \cong \mu/k_B$, one can show that

$$\Pi_0(\mathbf{q}, 0) \cong \text{const} = N(E_F), \tag{8.54}$$

where $N(E_F)$ is the electronic density of states at the Fermi energy, including a factor of two for the spin. Thus we obtain

$$\begin{aligned}
V_C^{\text{RPA}}(\mathbf{q}) &= \frac{4\pi \frac{e^2}{q^2}}{1 + 4\pi \frac{e^2}{q^2} \Pi_0} = 4\pi \frac{e^2}{q^2 + 4\pi e^2 \Pi_0} \\
&\cong 4\pi \frac{e^2}{q^2 + 4\pi e^2 N(E_F)} \\
&= 4\pi \frac{e^2}{q^2 + \kappa_s^2}
\end{aligned} \tag{8.55}$$

with

$$\kappa_s := \sqrt{4\pi e^2 N(E_F)}. \tag{8.56}$$

Note that summing up the more and more strongly diverging terms has led to a regular result in the limit $\mathbf{q} \rightarrow 0$. The result can be Fourier-transformed to give

$$V_C^{\text{RPA}}(\mathbf{r}) = e^2 \frac{e^{-\kappa_s r}}{r} \quad (8.57)$$

(not too much confusion should result from using the same symbol “ e ” for the elementary charge and the base of the exponential function). This is the *Yukawa potential*, which is exponentially suppressed beyond the screening length $1/\kappa_s$. This length is on the order of 10^{-8} m = 10 nm in typical metals. While we thus find a strong suppression of the repulsive interaction at large distances, there is no sign of it becoming attractive.

On the other hand, for *very* high frequencies $\nu \gtrsim E_F/\hbar$, the electron gas cannot follow the perturbation, the susceptibility and Π_0 go to zero, and we obtain the bare interaction,

$$V_C^{\text{RPA}}(\mathbf{q}, \nu \rightarrow \infty) \cong V_C(\mathbf{q}) = 4\pi \frac{e^2}{q^2}. \quad (8.58)$$

8.3 Electron-phonon interaction

The nuclei (or ion cores) in a crystal oscillate about their equilibrium positions. The quanta of these lattice vibrations are the phonons. The many-particle Hamiltonian including the phonons has the form

$$H = H_{\text{el}} + H_{\text{ph}} + H_{\text{el-ph}}, \quad (8.59)$$

where we have discussed the electronic part H_{el} before,

$$H_{\text{ph}} = \sum_{\mathbf{q}\lambda} \Omega_{\mathbf{q}\lambda} \left(b_{\mathbf{q}\lambda}^\dagger b_{\mathbf{q}\lambda} + \frac{1}{2} \right) \quad (8.60)$$

is the bare Hamiltonian of phonons with dispersion $\Omega_{\mathbf{q}\lambda}$, and

$$H_{\text{el-ph}} = \frac{1}{V} \sum_{\mathbf{k}\sigma} \sum_{\mathbf{q}\lambda} g_{\mathbf{q}\lambda} c_{\mathbf{k}+\mathbf{q},\sigma}^\dagger c_{\mathbf{k}\sigma} \left(b_{\mathbf{q}\lambda} + b_{-\mathbf{q},\lambda}^\dagger \right) \quad (8.61)$$

describes the electron-phonon coupling. $g_{\mathbf{q}\lambda}$ is the coupling strength. Physically, an electron can absorb ($b_{\mathbf{q}\lambda}$) or emit ($b_{-\mathbf{q},\lambda}^\dagger$) a phonon under conservation of momentum. Hence, electrons can interact with one another by exchanging phonons. Diagrammatically, we draw the simplest possible process as

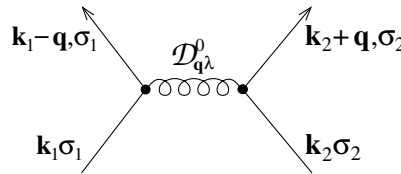

In detail, we define, in analogy to the Coulomb interaction

$$-V_C(\mathbf{q}) \equiv \text{~~~~~}, \quad (8.62)$$

the interaction due to phonon exchange,

$$-V_{\text{ph}}(\mathbf{q}, \lambda, i\nu_n) \equiv -\frac{1}{V} |g_{\mathbf{q}\lambda}|^2 \mathcal{D}_{\mathbf{q}\lambda}^0(i\nu_n) \equiv \text{~~~~~}. \quad (8.63)$$

We quote the expression for the bare phonon Green function, i.e., the one obtained from H_{ph} alone:

$$\mathcal{D}_{\mathbf{q}\lambda}^0(i\nu_n) = \frac{1}{i\nu_n - \Omega_{\mathbf{q}\lambda}} + \frac{1}{-i\nu_n - \Omega_{\mathbf{q}\lambda}} = \frac{2\Omega_{\mathbf{q}\lambda}}{(i\nu_n)^2 - \Omega_{\mathbf{q}\lambda}^2}. \quad (8.64)$$

The two terms in the intermediate form correspond to the two possible directions of propagation of the phonon. The phonon-mediated interaction is thus frequency-dependent, whereas the Coulomb interaction is static. However, we could write the bare Coulomb interaction in a very similar form as the exchange of *photons*. Since the speed of light is so much larger than the speed of sound, we can neglect the dynamics for photon exchange but not for phonon exchange.

Jellium phonons

For our discussions we need a specific model for phonons. We use the simplest one, based on the *jellium approximation* for the ion cores (i.e., the nuclei with the tightly bound electrons). In this approximation we describe the ion cores by a smooth positive charge density $\rho_+(\mathbf{r}, t)$. In equilibrium, this charge density is uniform, $\rho_+(\mathbf{r}, t) = \rho_+^0$. We consider small deviations

$$\rho_+(\mathbf{r}, t) = \rho_+^0 + \delta\rho_+(\mathbf{r}, t). \quad (8.65)$$

Gauss' law reads

$$\nabla \cdot \mathbf{E} = 4\pi \delta\rho_+(\mathbf{r}, t) \quad (8.66)$$

since ρ_+^0 is compensated by the average electronic charge density (the Hartree term). The density of force acting on ρ_+ is $\mathbf{f} = \rho_+ \mathbf{E} \cong \rho_+^0 \mathbf{E}$ to leading order in $\delta\rho_+$. Thus

$$\nabla \cdot \mathbf{f} \cong 4\pi \rho_+^0 \delta\rho_+. \quad (8.67)$$

The conservation of charge is expressed by the continuity equation

$$\frac{\partial}{\partial t} \rho_+ + \nabla \cdot \mathbf{j}_+ \equiv \frac{\partial}{\partial t} \rho_+ + \nabla \cdot \rho_+ \mathbf{v} = 0. \quad (8.68)$$

To leading order this reads (note that the velocity \mathbf{v} vanishes in equilibrium)

$$\frac{\partial}{\partial t} \delta\rho_+ + \rho_+^0 \nabla \cdot \mathbf{v} \cong 0 \quad (8.69)$$

$$\Rightarrow \frac{\partial^2}{\partial t^2} \delta\rho_+ \cong -\rho_+^0 \nabla \cdot \frac{\partial}{\partial t} \mathbf{v} \stackrel{\text{Newton}}{=} -\rho_+^0 \nabla \cdot \frac{\mathbf{f}}{\rho_m}, \quad (8.70)$$

where ρ_m is the *mass* density of the ion cores, which is dominated by the nuclear mass. With the charge $Z_{\text{eff}} e$ and mass M of the ion cores, we obtain

$$\frac{\partial^2}{\partial t^2} \delta\rho_+ \cong -\frac{Z_{\text{eff}} e}{M} \nabla \cdot \mathbf{f} = -\frac{Z_{\text{eff}} e}{M} 4\pi \rho_+^0 \delta\rho_+, \quad (8.71)$$

which is solved by

$$\delta\rho_+(\mathbf{r}, t) = \delta\rho_+(\mathbf{r}) e^{-i\Omega t}, \quad (8.72)$$

with

$$\Omega = \sqrt{4\pi \frac{Z_{\text{eff}} e}{M} \rho_+^0} = \sqrt{4\pi \frac{Z_{\text{eff}}^2 e^2}{M} n_+^0}, \quad (8.73)$$

where n_+^0 is the concentration of ions (or nuclei). We thus obtain *optical* phonons with completely flat dispersion, i.e., we find the same frequency Ω for all vibrations.

One can also calculate the coupling strength $g_{\mathbf{q}}$. It is clear that it will be controlled by the Coulomb interaction between electrons and fluctuations $\delta\rho_+$ in the jellium charge density. We refer to the lecture notes on many-particle theory and only give the result:

$$\frac{1}{V} |g_{\mathbf{q}}|^2 = \frac{\Omega}{2} V_C(\mathbf{q}). \quad (8.74)$$

Consequently, the electron-electron interaction due to phonon exchange becomes

$$V_{\text{ph}}(\mathbf{q}, i\nu_n) = \frac{1}{V} |g_{\mathbf{q}}|^2 \mathcal{D}_{\mathbf{q}}^0(i\nu_n) = \frac{\Omega}{2} V_C(\mathbf{q}) \frac{2\Omega}{(i\nu_n)^2 - \Omega^2} = V_C(\mathbf{q}) \frac{\Omega^2}{(i\nu_n)^2 - \Omega^2}. \quad (8.75)$$

It is thus proportional to the bare Coulomb interaction, with an additional frequency-dependent factor. The retarded form reads

$$V_{\text{ph}}^R(\mathbf{q}, \nu) = V_{\text{ph}}(\mathbf{q}, i\nu_n \rightarrow \nu + i0^+) = V_C(\mathbf{q}) \frac{\Omega^2}{(\nu + i0^+)^2 - \Omega^2} = V_C(\mathbf{q}) \frac{\Omega^2}{\nu^2 - \Omega^2 + i0^+ \text{sgn } \nu}, \quad (8.76)$$

where we have used $2\nu i0^+ = i0^+ \text{sgn } \nu$ and have neglected the square of infinitesimal quantities.

8.4 Effective interaction between electrons

Combining the bare Coulomb interaction and the bare interaction due to phonon exchange, calculated for the jellium model, we obtain the bare effective interaction between electrons,

$$\begin{aligned} V_{\text{eff}}(\mathbf{q}, i\nu_n) &:= V_C(\mathbf{q}) + V_{\text{ph}}(\mathbf{q}, i\nu_n) \\ &= V_C(\mathbf{q}) + V_C(\mathbf{q}) \frac{\Omega^2}{(i\nu_n)^2 - \Omega^2} \\ &= V_C(\mathbf{q}) \frac{(i\nu_n)^2}{(i\nu_n)^2 - \Omega^2}. \end{aligned} \quad (8.77)$$

The retarded form is

$$V_{\text{eff}}^R(\mathbf{q}, \nu) = V_{\text{eff}}(\mathbf{q}, i\nu_n \rightarrow \nu + i0^+) = V_C(\mathbf{q}) \frac{\nu^2}{\nu^2 - \Omega^2 + i0^+ \text{sgn } \nu}. \quad (8.78)$$

This expression is real except at $\nu = \Omega$ and has a pole there. Moreover, V_{eff}^R is proportional to V_C with a *negative* prefactor as long as $\nu < \Omega$.

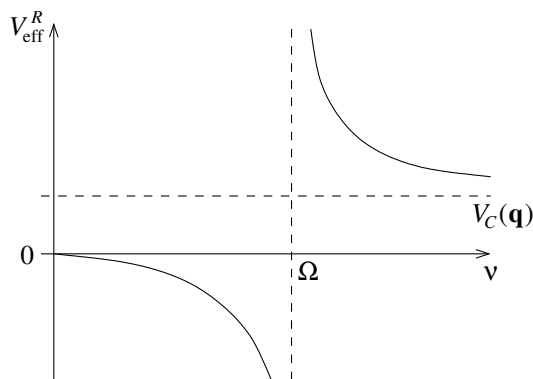

The effective interaction is thus *attractive* for $0 < \nu < \Omega$. The exchange of phonons overcompensates the repulsive Coulomb interaction. On the other hand, for $\nu \rightarrow 0$, the effective interaction vanishes. This means that in a quasi-static situation the electrons do not see each other at all.

What happens physically is that the electrons polarize the (jellium) charge density of the ion cores. The ions have a high inertial mass. Their reaction to a perturbation has a typical time scale of $1/\Omega$ or a frequency scale of Ω . For processes slow compared to Ω , the ion cores can completely screen the electron charge, forming a *polaron*, which is charge neutral. For frequencies $\nu > 0$, we have to think in terms of the response of the system to a test electron oscillating with frequency ν . The jellium acts as an oscillator with eigenfrequency Ω . At the present level of approximation it is an undamped oscillator. The jellium oscillator is excited at the frequency ν . For $0 < \nu < \Omega$, it is driven below its eigenfrequency and thus oscillates in phase with the test electron. The amplitude, i.e., the jellium polarization, is enhanced compared to the $\nu = 0$ limit simply because the system is closer to the resonance at Ω . Therefore, the oscillating electron charge is *overscreened*. On the other hand, for $\nu > \Omega$ the jellium oscillator is driven above its eigenfrequency and thus follows the test electron with a phase difference of π . Thus the electron charge is not screened at all but rather enhanced and the interaction is more strongly repulsive than the pure Coulomb interaction.

Screening of the effective interaction

From our discussion of the Coulomb interaction we know that the real interaction between two electrons in a metal is strongly screened at all except very short distances. This screening is well described within the RPA. We now apply the RPA to the effective interaction derived above. We define

$$-V_{\text{eff}} \equiv \text{~~~~~} = \text{~~~~~} + \text{~~~~~} \quad (8.79)$$

and

$$-V_{\text{eff}}^{\text{RPA}} \equiv \text{~~~~~} := \text{~~~~~} + \text{~~~~~} + \text{~~~~~} + \dots \quad (8.80)$$

or

$$\begin{aligned} -V_{\text{eff}}^{\text{RPA}}(\mathbf{q}, i\nu_n) &= -V_{\text{eff}}(\mathbf{q}, i\nu_n) + V_{\text{eff}}(\mathbf{q}, i\nu_n) \Pi_0(\mathbf{q}, i\nu_n) V_{\text{eff}}(\mathbf{q}, i\nu_n) \\ &\quad - V_{\text{eff}}(\mathbf{q}, i\nu_n) \Pi_0(\mathbf{q}, i\nu_n) V_{\text{eff}}(\mathbf{q}, i\nu_n) \Pi_0(\mathbf{q}, i\nu_n) V_{\text{eff}}(\mathbf{q}, i\nu_n) + \dots \end{aligned} \quad (8.81)$$

As above, we can sum this up,

$$\begin{aligned} V_{\text{eff}}^{\text{RPA}}(\mathbf{q}, i\nu_n) &= \frac{V_{\text{eff}}(\mathbf{q}, i\nu_n)}{1 + V_{\text{eff}}(\mathbf{q}, i\nu_n) \Pi_0(\mathbf{q}, i\nu_n)} = V_C(\mathbf{q}) \frac{\frac{(i\nu_n)^2}{(i\nu_n)^2 - \Omega^2}}{1 + V_C(\mathbf{q}) \frac{(i\nu_n)^2}{(i\nu_n)^2 - \Omega^2} \Pi_0(\mathbf{q}, i\nu_n)} \\ &= V_C(\mathbf{q}) \frac{(i\nu_n)^2}{(i\nu_n)^2 - \Omega^2 + (i\nu_n)^2 V_C(\mathbf{q}) \Pi_0(\mathbf{q}, i\nu_n)} \\ &= \frac{V_C(\mathbf{q})}{\underbrace{1 + V_C(\mathbf{q}) \Pi_0(\mathbf{q}, i\nu_n)}_{= V_C^{\text{RPA}}(\mathbf{q}, i\nu_n)}} \frac{(i\nu_n)^2 + (i\nu_n)^2 V_C(\mathbf{q}) \Pi_0(\mathbf{q}, i\nu_n)}{(i\nu_n)^2 - \Omega^2 + (i\nu_n)^2 V_C(\mathbf{q}) \Pi_0(\mathbf{q}, i\nu_n)} \\ &= V_C^{\text{RPA}}(\mathbf{q}, i\nu_n) \frac{(i\nu_n)^2}{(i\nu_n)^2 - \frac{\Omega^2}{1 + V_C(\mathbf{q}) \Pi_0(\mathbf{q}, i\nu_n)}} \\ &= V_C^{\text{RPA}}(\mathbf{q}, i\nu_n) \frac{(i\nu_n)^2}{(i\nu_n)^2 - \omega_{\mathbf{q}}^2(i\nu_n)} \end{aligned} \quad (8.82)$$

with the *renormalized phonon frequency*

$$\omega_{\mathbf{q}}(i\nu_n) := \frac{\Omega}{\sqrt{1 + V_C(\mathbf{q}) \Pi_0(\mathbf{q}, i\nu_n)}}. \quad (8.83)$$

To see that this is a reasonable terminology, compare $V_{\text{eff}}^{\text{RPA}}$ to the bare effective interaction

$$V_{\text{eff}}(\mathbf{q}, i\nu_n) = V_C(\mathbf{q}) \frac{(i\nu_n)^2}{(i\nu_n)^2 - \Omega^2}. \quad (8.84)$$

Evidently, screening leads to the replacements $V_C \rightarrow V_C^{\text{RPA}}$ and $\Omega \rightarrow \omega_{\mathbf{q}}$.

For small momenta and frequencies, we have $\Pi_0 \rightarrow N(E_F)$, the density of states at E_F . In this limit we thus obtain

$$\omega_{\mathbf{q}} \cong \frac{\Omega}{\sqrt{1 + 4\pi \frac{e^2}{q^2} N(E_F)}} = \frac{\Omega}{\sqrt{1 + \frac{\kappa_s^2}{q^2}}} \cong \frac{\Omega}{\sqrt{\frac{\kappa_s^2}{q^2}}} = \frac{\Omega}{\kappa_s} q. \quad (8.85)$$

Due to screening we thus find an *acoustic* dispersion of jellium phonons. This is of course much more realistic than an optical Einstein mode.

Beyond the low-frequency limit it is important that Π_0 and thus $\omega_{\mathbf{q}}$ obtains a sizable imaginary part. It smears out the pole in the retarded interaction $V_{\text{eff}}^{\text{RPA}}(\mathbf{q}, \nu)$ or rather moves it away from the real-frequency axis—the lattice vibrations are now damped. The real part of the retarded interaction is sketched here for fixed \mathbf{q} :

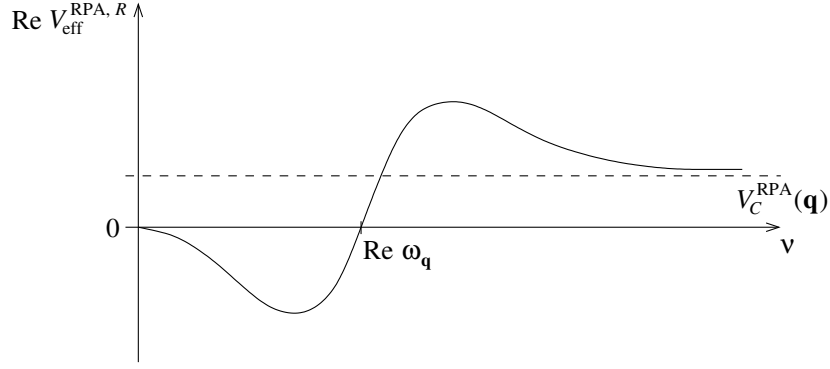

Note that

- the interaction still vanishes in the static limit $\nu \rightarrow 0$,
- the interaction is attractive for $0 < \nu < \text{Re } \omega_{\mathbf{q}}$, where $\text{Re } \omega_{\mathbf{q}} \sim q$.

It is important that the static interaction is not attractive but zero. Hence, we do not expect *static* bound states of two electrons.

To obtain analytical results, it is necessary to simplify the interaction. The main property required for superconductivity is that the interaction is attractive for frequencies below some typical phonon frequency. The typical phonon frequency is the material specific *Debye frequency* ω_D . We write the effective RPA interaction in terms of the incoming and transferred momenta and frequencies,

$$V_{\text{eff}}^{\text{RPA}} = V_{\text{eff}}^{\text{RPA}}(\mathbf{k}, i\omega_n; \mathbf{k}', i\omega'_n; \mathbf{q}, i\nu_n). \quad (8.86)$$

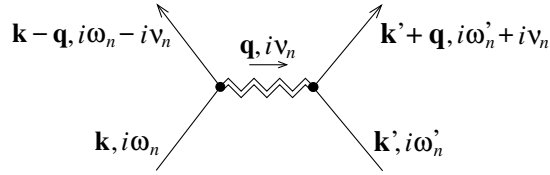

We then approximate the interaction (very crudely) by a constant $-V_0 < 0$ if both incoming frequencies are smaller than ω_D and by zero otherwise,

$$V_{\text{eff}}^{\text{RPA}} \approx \begin{cases} -V_0 & \text{for } |i\omega_n|, |i\omega'_n| < \omega_D, \\ 0 & \text{otherwise.} \end{cases} \quad (8.87)$$

This approximate interaction is evidently nonzero in the static limit and therefore could lead to bound states. Such bound states would be an artifact of the approximation and should be disregarded.

Cooper instability and BCS ground state

In this chapter we will first show that the attractive effective interaction leads to an instability of the normal state, i.e., of the Fermi sea. Then we will discuss the new state that takes its place.

9.1 Cooper instability

Let us consider the scattering of two electrons due to the effective interaction. A single scattering event is represented by the diagram

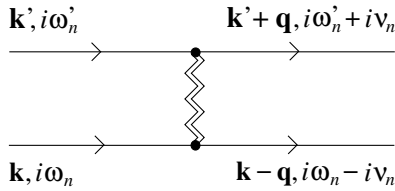

Electrons can also scatter multiple times:

(9.1)

An instability occurs if this series diverges since then the scattering becomes infinitely strong. The diagrams represent a perturbative expansion in the interaction strength V_0 about the noninteracting Fermi gas. A divergence of the series signals a breakdown of perturbation theory. This means that the true equilibrium state cannot be obtained from the equilibrium state for $V_0 = 0$, i.e., the Fermi gas, by perturbation theory. A state that is perturbatively connected to the free Fermi gas is called a Landau Fermi liquid. It is an appropriate description for normal metals. Hence, a scattering instability implies that the equilibrium state is not a Fermi liquid.

Like in the RPA, it turns out to be sufficient to consider the dominant diagrams at each order. These are the *ladder diagrams*, which do not contain crossing interaction lines. Moreover, the instability occurs first for the scattering of two electrons with opposite momentum, frequency, and spin. We thus restrict ourselves to the diagrams describing this situation. It is plausible that the scattering between states with opposite momenta dominates: the total momentum of the two electrons is then zero, of course, which gives the largest phase space of possible final states.

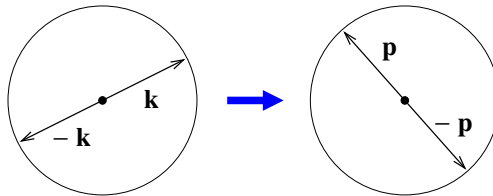

We define the *scattering vertex* Λ by

$$\begin{aligned}
-\Lambda &\equiv \begin{array}{c} \begin{array}{ccc} \xrightarrow{-\mathbf{k} \downarrow -i\omega_n} & \xrightarrow{-\mathbf{p} \downarrow -i\Omega_n} & \\ \hline \xrightarrow{\mathbf{k} \uparrow i\omega_n} & \xrightarrow{\mathbf{p} \uparrow i\Omega_n} & \end{array} \\ \end{array} \\
:= &\begin{array}{c} \begin{array}{ccc} \xrightarrow{-\mathbf{k} \downarrow -i\omega_n} & \xrightarrow{-\mathbf{p} \downarrow -i\Omega_n} & \\ \hline \xrightarrow{\mathbf{k} \uparrow i\omega_n} & \xrightarrow{\mathbf{p} \uparrow i\Omega_n} & \end{array} \\ \end{array} \\
&+ \begin{array}{c} \begin{array}{ccc} \xrightarrow{-\mathbf{k} \downarrow -i\omega_n} & \xrightarrow{-\mathbf{k}_1 \downarrow -i\omega_n^1} & \xrightarrow{-\mathbf{p} \downarrow -i\Omega_n} \\ \hline \xrightarrow{\mathbf{k} \uparrow i\omega_n} & \xrightarrow{\mathbf{k}_1 \uparrow i\omega_n^1} & \xrightarrow{\mathbf{p} \uparrow i\Omega_n} \end{array} \\ \end{array} \\
&+ \dots
\end{aligned} \tag{9.2}$$

This is a geometric series, which we can sum up,

$$\begin{array}{c} \begin{array}{ccc} \xrightarrow{-\mathbf{k} \downarrow -i\omega_n} & \xrightarrow{-\mathbf{p} \downarrow -i\Omega_n} & \\ \hline \xrightarrow{\mathbf{k} \uparrow i\omega_n} & \xrightarrow{\mathbf{p} \uparrow i\Omega_n} & \end{array} \\ \Lambda \end{array} = \begin{array}{c} \begin{array}{ccc} \xrightarrow{-\mathbf{k} \downarrow -i\omega_n} & \xrightarrow{-\mathbf{p} \downarrow -i\Omega_n} & \\ \hline \xrightarrow{\mathbf{k} \uparrow i\omega_n} & \xrightarrow{\mathbf{p} \uparrow i\Omega_n} & \end{array} \\ \end{array} \left[1 + \begin{array}{c} \begin{array}{ccc} \xrightarrow{-\mathbf{k} \downarrow -i\omega_n} & \xrightarrow{-\mathbf{p} \downarrow -i\Omega_n} & \\ \hline \xrightarrow{\mathbf{k} \uparrow i\omega_n} & \xrightarrow{\mathbf{p} \uparrow i\Omega_n} & \end{array} \\ \end{array} + \begin{array}{c} \begin{array}{ccc} \xrightarrow{-\mathbf{k} \downarrow -i\omega_n} & \xrightarrow{-\mathbf{k}_1 \downarrow -i\omega_n^1} & \xrightarrow{-\mathbf{p} \downarrow -i\Omega_n} \\ \hline \xrightarrow{\mathbf{k} \uparrow i\omega_n} & \xrightarrow{\mathbf{k}_1 \uparrow i\omega_n^1} & \xrightarrow{\mathbf{p} \uparrow i\Omega_n} \end{array} \\ \end{array} + \dots \right] = \begin{array}{c} \begin{array}{ccc} \xrightarrow{-\mathbf{k} \downarrow -i\omega_n} & \xrightarrow{-\mathbf{p} \downarrow -i\Omega_n} & \\ \hline \xrightarrow{\mathbf{k} \uparrow i\omega_n} & \xrightarrow{\mathbf{p} \uparrow i\Omega_n} & \end{array} \\ \end{array} \frac{1}{1 - \begin{array}{c} \begin{array}{ccc} \xrightarrow{-\mathbf{k} \downarrow -i\omega_n} & \xrightarrow{-\mathbf{p} \downarrow -i\Omega_n} & \\ \hline \xrightarrow{\mathbf{k} \uparrow i\omega_n} & \xrightarrow{\mathbf{p} \uparrow i\Omega_n} & \end{array} \end{array}} \tag{9.3}$$

With our approximation

$$V_{\text{eff}}^{\text{RPA}} \approx \begin{cases} -V_0 & \text{for } |\omega_n|, |\Omega_n| < \omega_D, \\ 0 & \text{otherwise,} \end{cases} \tag{9.4}$$

we obtain

$$-\Lambda(i\omega_n, i\Omega_n) \approx \frac{+V_0}{1 - V_0 \frac{1}{\beta} \sum_{i\omega'_n, |\omega'_n| < \omega_D} \frac{1}{V} \sum_{\mathbf{k}'} \mathcal{G}_{\mathbf{k}'\uparrow}^0(i\omega'_n) \mathcal{G}_{-\mathbf{k}'\downarrow}^0(-i\omega'_n)} \tag{9.5}$$

for $|\omega_n|, |\Omega_n| < \omega_D$ and zero otherwise. Thus

$$\Lambda(i\omega_n, i\Omega_n) \approx \begin{cases} \frac{-V_0}{1 - V_0 \frac{1}{\beta} \sum_{i\omega'_n, |\omega'_n| < \omega_D} \frac{1}{V} \sum_{\mathbf{k}'} \mathcal{G}_{\mathbf{k}'\uparrow}^0(i\omega'_n) \mathcal{G}_{-\mathbf{k}'\downarrow}^0(-i\omega'_n)} & \text{for } |\omega_n|, |\Omega_n| < \omega_D, \\ 0 & \text{otherwise.} \end{cases} \tag{9.6}$$

We see that the scattering vertex Λ diverges if

$$V_0 \frac{1}{\beta} \sum_{\substack{i\omega'_n \\ |\omega'_n| < \omega_D}} \frac{1}{V} \sum_{\mathbf{k}'} \mathcal{G}_{\mathbf{k}'\uparrow}^0(i\omega'_n) \mathcal{G}_{-\mathbf{k}'\downarrow}^0(-i\omega'_n) = 1. \tag{9.7}$$

This expression depends on temperature. We now evaluate it explicitly:

$$\dots = V_0 k_B T \sum_{\substack{i\omega'_n \\ |\omega'_n| < \omega_D}} \frac{1}{V} \sum_{\mathbf{k}'} \frac{1}{i\omega'_n - \xi_{\mathbf{k}'}} \frac{1}{-i\omega'_n - \xi_{\mathbf{k}'}} = V_0 k_B T \sum_{\substack{i\omega'_n \\ |\omega'_n| < \omega_D}} \int_{-\infty}^{\infty} d\xi D(\mu + \xi) \frac{1}{(\omega'_n)^2 + \xi^2}, \tag{9.8}$$

where $D(\epsilon)$ is the density of states per spin direction and per unit cell. Assuming the density of states to be approximately constant close to the Fermi energy, we get (with $\hbar = 1$)

$$\dots \approx V_0 k_B T \sum_{\substack{i\omega'_n \\ |\omega'_n| < \omega_D}} D(E_F) \underbrace{\int_{-\infty}^{\infty} \frac{d\xi}{(\omega'_n)^2 + \xi^2}}_{= \pi/|\omega'_n|}$$

$$\begin{aligned}
&= V_0 k_B T D(E_F) \pi 2 \sum_{n=0}^{\beta\omega_D/2\pi} \frac{1}{\frac{(2n+1)\pi}{\beta}} = V_0 k_B T D(E_F) \beta \sum_{n=0}^{\beta\omega_D/2\pi} \frac{1}{n + \frac{1}{2}} \\
&\cong V_0 D(E_F) \left[\gamma + \ln \left(4 \frac{\beta\omega_D}{2\pi} \right) \right].
\end{aligned} \tag{9.9}$$

Here, $\gamma \approx 0.577216$ is the Euler constant. In the last step we have used an approximation for the sum over n that is valid for $\beta\omega_D \gg 1$, i.e., if the sum has many terms. Since T_c for superconductors is typically small compared to the Debye temperature ω_D/k_B (a few hundred Kelvin), this is justified. Altogether, we find

$$\Lambda \approx \frac{-V_0}{1 - V_0 D(E_F) \left(\gamma + \ln \frac{2\beta\omega_D}{\pi} \right)} \tag{9.10}$$

for $|i\omega_n| < \omega_D$. Coming from high temperatures, but still satisfying $k_B T \ll \omega_D$, multiple scattering enhances Λ . Λ diverges at $T = T_c$, where

$$V_0 D(E_F) \left(\gamma + \ln \frac{2\omega_D}{\pi k_B T_c} \right) = 1 \tag{9.11}$$

$$\Rightarrow \ln \frac{2e^\gamma \omega_D}{\pi k_B T_c} = \frac{1}{V_0 D(E_F)} \tag{9.12}$$

$$\Rightarrow k_B T_c = \underbrace{\frac{2e^\gamma}{\pi}}_{\approx 1.13387 \sim 1} \omega_D \exp \left(-\frac{1}{V_0 D(E_F)} \right). \tag{9.13}$$

This is the *Cooper instability*. Its characteristic temperature scale appears to be the Debye temperature of a few hundred Kelvin. This is disturbing since we do not observe an instability at such high temperatures, except perhaps in H₃S and other hydrides. However, the exponential factor tends to be on the order of 1/100 so that we obtain T_c of a few Kelvin.

It is important to realize that we find an instability of the normal metal towards a superconducting state for any, arbitrarily weak attractive interaction. It is therefore called a *weak-coupling instability*. This behavior is not shared by all mean-field theories: for example, the Stoner theory of ferromagnetism in metals predicts an instability only if the (Hubbard) interaction U exceeds a critical value of $U_c \propto 1/D(E_F)$. The weak-coupling Cooper instability helps to understand why superconductivity is so common among the elemental metals.

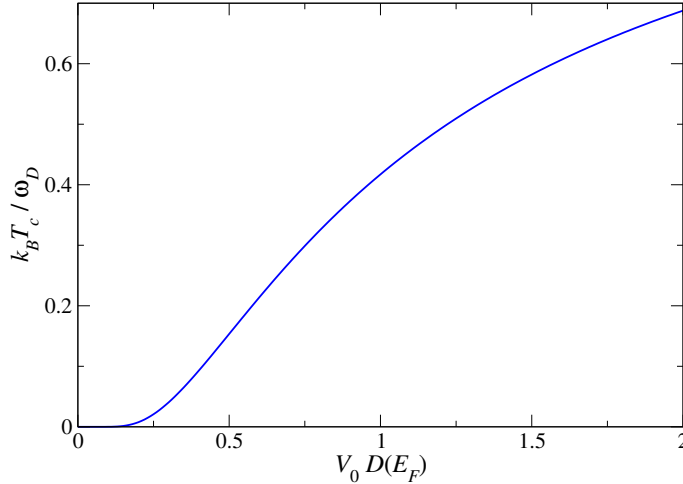

Also note that $k_B T_c$ is not analytic in V_0 at $V_0 = 0$ (the function has an essential singularity there). Thus $k_B T_c$ cannot be expanded into a Taylor series around the non-interacting limit. This means that we cannot obtain $k_B T_c$ in perturbation theory in V_0 to any finite order. BCS theory is indeed non-perturbative.

9.2 The BCS ground state

We have seen that the Fermi sea becomes unstable due to the scattering of electrons in states $|\mathbf{k}, \uparrow\rangle$ and $|\mathbf{-k}, \downarrow\rangle$. Bardeen, Cooper, and Schrieffer (BCS) have proposed an ansatz for the new ground state. It is based on the idea that electrons from the states $|\mathbf{k}, \uparrow\rangle$ and $|\mathbf{-k}, \downarrow\rangle$ form (so-called Cooper) pairs and that the ground state is a superposition of states built up of such pairs. The ansatz reads

$$|\psi_{\text{BCS}}\rangle = \prod_{\mathbf{k}} \left(u_{\mathbf{k}} + v_{\mathbf{k}} c_{\mathbf{k}\uparrow}^\dagger c_{-\mathbf{k},\downarrow}^\dagger \right) |0\rangle, \quad (9.14)$$

where $|0\rangle$ is the vacuum state without any electrons and $u_{\mathbf{k}}, v_{\mathbf{k}}$ are as yet unknown complex coefficients. Normalization requires

$$\begin{aligned} 1 &= \langle \psi_{\text{BCS}} | \psi_{\text{BCS}} \rangle \\ &= \langle 0 | \prod_{\mathbf{k}} (u_{\mathbf{k}}^* + v_{\mathbf{k}}^* c_{-\mathbf{k},\downarrow} c_{\mathbf{k}\uparrow}) \prod_{\mathbf{k}'} (u_{\mathbf{k}'} + v_{\mathbf{k}'} c_{\mathbf{k}'\uparrow}^\dagger c_{-\mathbf{k}',\downarrow}^\dagger) |0\rangle \quad \left| \begin{array}{l} \text{exact reordering,} \\ \text{combining factors with same } \mathbf{k} \end{array} \right. \\ &= \langle 0 | \prod_{\mathbf{k}} (|u_{\mathbf{k}}|^2 + u_{\mathbf{k}}^* v_{\mathbf{k}} c_{\mathbf{k}\uparrow}^\dagger c_{-\mathbf{k},\downarrow}^\dagger + u_{\mathbf{k}} v_{\mathbf{k}}^* c_{-\mathbf{k},\downarrow} c_{\mathbf{k}\uparrow} + |v_{\mathbf{k}}|^2) |0\rangle \\ &= \prod_{\mathbf{k}} (|u_{\mathbf{k}}|^2 + |v_{\mathbf{k}}|^2). \end{aligned} \quad (9.15)$$

This is certainly satisfied if we demand $|u_{\mathbf{k}}|^2 + |v_{\mathbf{k}}|^2 = 1$ for all \mathbf{k} , which we will do from now on.

Note that the occupations of $|\mathbf{k}, \uparrow\rangle$ and $|\mathbf{-k}, \downarrow\rangle$ are maximally correlated; either both are occupied or both are empty. Also, $|\psi_{\text{BCS}}\rangle$ is peculiar in that it is a superposition of states with different total electron numbers. This means that the electron number fluctuates; we are dealing with quantum fluctuations here since we are considering a pure state. The fluctuations between a certain pair being present or absent agree with the earlier statement that the superconducting state should not consist of *statically* bound pairs. (We could imagine the superconductor to be entangled with a much larger electron reservoir so that the total electron number in superconductor and reservoir is fixed.) As a consequence, expressions containing unequal numbers of electronic creation and annihilation operators can have non-vanishing expectation values. For example,

$$\begin{aligned} \langle c_{\mathbf{k}\uparrow}^\dagger c_{-\mathbf{k},\downarrow}^\dagger \rangle_{\text{BCS}} &\equiv \langle \psi_{\text{BCS}} | c_{\mathbf{k}\uparrow}^\dagger c_{-\mathbf{k},\downarrow}^\dagger | \psi_{\text{BCS}} \rangle \\ &= \langle 0 | \prod_{\mathbf{k}'} (u_{\mathbf{k}'}^* + v_{\mathbf{k}'}^* c_{-\mathbf{k}',\downarrow} c_{\mathbf{k}'\uparrow}) c_{\mathbf{k}\uparrow}^\dagger c_{-\mathbf{k},\downarrow}^\dagger \prod_{\mathbf{k}''} (u_{\mathbf{k}''} + v_{\mathbf{k}''} c_{\mathbf{k}''\uparrow}^\dagger c_{-\mathbf{k}'',\downarrow}^\dagger) |0\rangle \\ &= \langle 0 | v_{\mathbf{k}}^* c_{-\mathbf{k},\downarrow} c_{-\mathbf{k},\downarrow}^\dagger \prod_{\mathbf{k}' \neq \mathbf{k}} (u_{\mathbf{k}'}^* + v_{\mathbf{k}'}^* c_{-\mathbf{k}',\downarrow} c_{\mathbf{k}'\uparrow}) \prod_{\mathbf{k}''} (u_{\mathbf{k}''} + v_{\mathbf{k}''} c_{\mathbf{k}''\uparrow}^\dagger c_{-\mathbf{k}'',\downarrow}^\dagger) |0\rangle \\ &\quad \left| \begin{array}{l} \text{since } cc^\dagger = 1 - c^\dagger c \text{ and } \langle 0 | c^\dagger = 0 \end{array} \right. \\ &= \langle 0 | v_{\mathbf{k}}^* \prod_{\mathbf{k}' \neq \mathbf{k}} (u_{\mathbf{k}'}^* + v_{\mathbf{k}'}^* c_{-\mathbf{k}',\downarrow} c_{\mathbf{k}'\uparrow}) \prod_{\mathbf{k}''} (u_{\mathbf{k}''} + v_{\mathbf{k}''} c_{\mathbf{k}''\uparrow}^\dagger c_{-\mathbf{k}'',\downarrow}^\dagger) |0\rangle \\ &= \langle 0 | v_{\mathbf{k}}^* (u_{\mathbf{k}} + v_{\mathbf{k}} c_{\mathbf{k}\uparrow}^\dagger c_{-\mathbf{k},\downarrow}^\dagger) \prod_{\mathbf{k}' \neq \mathbf{k}} \underbrace{(|u_{\mathbf{k}'}|^2 + |v_{\mathbf{k}'}|^2)}_{=1} |0\rangle = v_{\mathbf{k}}^* u_{\mathbf{k}}. \end{aligned} \quad (9.16)$$

The coefficients $u_{\mathbf{k}}, v_{\mathbf{k}}$ are chosen so as to minimize the expectation value of the energy, $\langle \psi_{\text{BCS}} | H | \psi_{\text{BCS}} \rangle$, under the constraint $|u_{\mathbf{k}}|^2 + |v_{\mathbf{k}}|^2 = 1$ for all \mathbf{k} . $|\psi_{\text{BCS}}\rangle$ is thus a *variational ansatz*.

We write the Hamiltonian as

$$H = \sum_{\mathbf{k}\sigma} \xi_{\mathbf{k}} c_{\mathbf{k}\sigma}^\dagger c_{\mathbf{k}\sigma} + V_{\text{int}} \quad (9.17)$$

and, in the spirit of the previous section, choose the simplest non-trivial approximation for V_{int} that takes the following into account:

1. Only electrons with energies $|\xi_{\mathbf{k}}| \lesssim \omega_D$ relative to the Fermi energy are important. Note that this surreptitiously replaces what was originally a cutoff in frequency by a cutoff in momentum.

2. The instability is due to the scattering between electrons in the single-particle states $|\mathbf{k}, \uparrow\rangle$ and $|\mathbf{-k}, \downarrow\rangle$. These are related to each other by time reversal.

This leads to

$$V_{\text{int}} = \frac{1}{N} \sum_{\mathbf{k}\mathbf{k}'} V_{\mathbf{k}\mathbf{k}'} c_{\mathbf{k}\uparrow}^\dagger c_{-\mathbf{k},\downarrow}^\dagger c_{-\mathbf{k}',\downarrow} c_{\mathbf{k}'\uparrow} \quad (9.18)$$

with

$$V_{\mathbf{k}\mathbf{k}'} = \begin{cases} -V_0 & \text{for } |\xi_{\mathbf{k}}| < \omega_D \text{ and } |\xi_{\mathbf{k}'}| < \omega_D, \\ 0 & \text{otherwise.} \end{cases} \quad (9.19)$$

This simplified model is in fact somewhat strange and should not be overinterpreted. We come back to this in Sec. 10.3.

We assume that scattering without momentum transfer, $\mathbf{k}' = \mathbf{k}$, contributes negligibly compared to $\mathbf{k}' \neq \mathbf{k}$ since there are many more scattering channels for $\mathbf{k}' \neq \mathbf{k}$. We also assume that $u_{-\mathbf{k}} = u_{\mathbf{k}}$, $v_{-\mathbf{k}} = v_{\mathbf{k}}$, which is, at worst, a restriction of our variational ansatz. With this, we obtain

$$\begin{aligned} \langle \psi_{\text{BCS}} | H | \psi_{\text{BCS}} \rangle &= \sum_{\mathbf{k}\sigma} \xi_{\mathbf{k}} \langle 0 | \prod_{\mathbf{q}} (u_{\mathbf{q}}^* + v_{\mathbf{q}}^* c_{-\mathbf{q},\downarrow} c_{\mathbf{q}\uparrow}) c_{\mathbf{k}\sigma}^\dagger c_{\mathbf{k}\sigma} \prod_{\mathbf{q}'} (u_{\mathbf{q}'} + v_{\mathbf{q}'} c_{\mathbf{q}'\uparrow}^\dagger c_{-\mathbf{q}',\downarrow}^\dagger) | 0 \rangle \\ &+ \frac{1}{N} \sum_{\mathbf{k}\mathbf{k}'} V_{\mathbf{k}\mathbf{k}'} \langle 0 | \prod_{\mathbf{q}} (u_{\mathbf{q}}^* + v_{\mathbf{q}}^* c_{-\mathbf{q},\downarrow} c_{\mathbf{q}\uparrow}) c_{\mathbf{k}\uparrow}^\dagger c_{-\mathbf{k},\downarrow}^\dagger c_{-\mathbf{k}'\downarrow} c_{\mathbf{k}'\uparrow} \prod_{\mathbf{q}'} (u_{\mathbf{q}'} + v_{\mathbf{q}'} c_{\mathbf{q}'\uparrow}^\dagger c_{-\mathbf{q}',\downarrow}^\dagger) | 0 \rangle. \end{aligned} \quad (9.20)$$

Only those terms in the products over \mathbf{q} , \mathbf{q}' contribute that make sure that the same fermions are first created and then annihilated. For the interaction term, this is somewhat subtle. We discuss the first product, over \mathbf{q} . Special values of \mathbf{q} that must be considered separately are $\mathbf{q} = \mathbf{k}$ and $\mathbf{q} = \mathbf{k}'$. For $\mathbf{q} = \mathbf{k}$, the two electrons created by $c_{\mathbf{k}\uparrow}^\dagger c_{-\mathbf{k},\downarrow}^\dagger$ must be annihilated by $c_{-\mathbf{k},\downarrow} c_{\mathbf{k}\uparrow}$ so that only the term containing $v_{\mathbf{q}}^* = v_{\mathbf{k}}^*$ survives. For $\mathbf{q} = \mathbf{k}'$, the $v_{\mathbf{q}}^*$ term drops out since the same annihilation operators appear squared. Thus only the term containing $u_{\mathbf{q}}^* = u_{\mathbf{k}'}^*$ remains. The arguments for the second product, over \mathbf{q}' , are analogous. For all $\mathbf{q}, \mathbf{q}' \neq \mathbf{k}, \mathbf{k}'$, the four operators in the center are irrelevant and we obtain the same expression as in the normalization integral, containing $\prod_{\mathbf{q}} (|u_{\mathbf{q}}|^2 + |v_{\mathbf{q}}|^2) = 1$. Altogether, we obtain

$$\begin{aligned} \langle \psi_{\text{BCS}} | H | \psi_{\text{BCS}} \rangle &= \sum_{\mathbf{k}} \xi_{\mathbf{k}} \langle 0 | |v_{\mathbf{k}}|^2 c_{-\mathbf{k},\downarrow} c_{\mathbf{k}\uparrow} c_{\mathbf{k}\uparrow}^\dagger c_{-\mathbf{k},\downarrow}^\dagger | 0 \rangle + \sum_{\mathbf{k}} \xi_{\mathbf{k}} \langle 0 | |v_{-\mathbf{k}}|^2 c_{\mathbf{k}\downarrow} c_{-\mathbf{k},\uparrow} c_{\mathbf{k}\downarrow}^\dagger c_{-\mathbf{k},\uparrow}^\dagger | 0 \rangle \\ &+ \frac{1}{N} \sum_{\mathbf{k}\mathbf{k}'} V_{\mathbf{k}\mathbf{k}'} \langle 0 | v_{\mathbf{k}}^* u_{\mathbf{k}'}^* u_{\mathbf{k}} v_{\mathbf{k}'} c_{-\mathbf{k},\downarrow} c_{\mathbf{k}\uparrow} c_{\mathbf{k}\uparrow}^\dagger c_{-\mathbf{k},\downarrow}^\dagger c_{-\mathbf{k}',\downarrow} c_{\mathbf{k}'\uparrow} c_{\mathbf{k}'\uparrow}^\dagger c_{-\mathbf{k}',\downarrow}^\dagger | 0 \rangle \\ &= \sum_{\mathbf{k}} 2\xi_{\mathbf{k}} |v_{\mathbf{k}}|^2 + \frac{1}{N} \sum_{\mathbf{k}\mathbf{k}'} V_{\mathbf{k}\mathbf{k}'} v_{\mathbf{k}}^* u_{\mathbf{k}} u_{\mathbf{k}'}^* v_{\mathbf{k}'} =: E_{\text{BCS}}. \end{aligned} \quad (9.21)$$

This energy should be minimized with respect to the $u_{\mathbf{k}}, v_{\mathbf{k}}$. For E_{BCS} to be real, the phases of $u_{\mathbf{k}}$ and $v_{\mathbf{k}}$ must be the same. But since E_{BCS} is invariant under

$$u_{\mathbf{k}} \rightarrow u_{\mathbf{k}} e^{i\varphi_{\mathbf{k}}}, \quad v_{\mathbf{k}} \rightarrow v_{\mathbf{k}} e^{i\varphi_{\mathbf{k}}}, \quad (9.22)$$

we can choose all $u_{\mathbf{k}}, v_{\mathbf{k}}$ real. The constraint from normalization then reads $u_{\mathbf{k}}^2 + v_{\mathbf{k}}^2 = 1$ and we can parameterize the coefficients by

$$u_{\mathbf{k}} = \cos \theta_{\mathbf{k}}, \quad v_{\mathbf{k}} = \sin \theta_{\mathbf{k}}. \quad (9.23)$$

Then

$$\begin{aligned} E_{\text{BCS}} &= \sum_{\mathbf{k}} 2\xi_{\mathbf{k}} \sin^2 \theta_{\mathbf{k}} + \frac{1}{N} \sum_{\mathbf{k}\mathbf{k}'} V_{\mathbf{k}\mathbf{k}'} \sin \theta_{\mathbf{k}} \cos \theta_{\mathbf{k}} \sin \theta_{\mathbf{k}'} \cos \theta_{\mathbf{k}'} \\ &= \sum_{\mathbf{k}} \xi_{\mathbf{k}} (1 - \cos 2\theta_{\mathbf{k}}) + \frac{1}{N} \sum_{\mathbf{k}\mathbf{k}'} \frac{V_{\mathbf{k}\mathbf{k}'}}{4} \sin 2\theta_{\mathbf{k}} \sin 2\theta_{\mathbf{k}'}. \end{aligned} \quad (9.24)$$

We obtain the minimum from

$$\begin{aligned}\frac{\partial E_{\text{BCS}}}{\partial \theta_{\mathbf{q}}} &= 2\xi_{\mathbf{q}} \sin 2\theta_{\mathbf{q}} + \frac{1}{N} \sum_{\mathbf{k}'} \frac{V_{\mathbf{qk}'}}{2} \cos 2\theta_{\mathbf{q}} \sin 2\theta_{\mathbf{k}'} + \frac{1}{N} \sum_{\mathbf{k}} \frac{V_{\mathbf{kq}}}{2} \sin 2\theta_{\mathbf{k}} \cos 2\theta_{\mathbf{q}} \\ &= 2\xi_{\mathbf{q}} \sin 2\theta_{\mathbf{q}} + \frac{1}{N} \sum_{\mathbf{k}'} V_{\mathbf{qk}'} \cos 2\theta_{\mathbf{q}} \sin 2\theta_{\mathbf{k}'} \stackrel{!}{=} 0.\end{aligned}\quad (9.25)$$

We replace \mathbf{q} by \mathbf{k} and parameterize $\theta_{\mathbf{k}}$ by

$$\sin 2\theta_{\mathbf{k}} =: \frac{\Delta_{\mathbf{k}}}{\sqrt{\xi_{\mathbf{k}}^2 + \Delta_{\mathbf{k}}^2}} \quad (9.26)$$

and write

$$\cos 2\theta_{\mathbf{k}} = \frac{\xi_{\mathbf{k}}}{\sqrt{\xi_{\mathbf{k}}^2 + \Delta_{\mathbf{k}}^2}}. \quad (9.27)$$

The last equality is only determined by the previous one up to the sign. We could convince ourselves that the other possible choice does not lead to a lower energy E_{BCS} . Equation (9.25) now becomes

$$2 \frac{\xi_{\mathbf{k}} \Delta_{\mathbf{k}}}{\sqrt{\xi_{\mathbf{k}}^2 + \Delta_{\mathbf{k}}^2}} + \frac{1}{N} \sum_{\mathbf{k}'} V_{\mathbf{k}\mathbf{k}'} \frac{\xi_{\mathbf{k}} \Delta_{\mathbf{k}'}}{\sqrt{\xi_{\mathbf{k}}^2 + \Delta_{\mathbf{k}}^2} \sqrt{\xi_{\mathbf{k}'}^2 + \Delta_{\mathbf{k}'}^2}} = 0 \quad (9.28)$$

$$\Rightarrow \Delta_{\mathbf{k}} = -\frac{1}{N} \sum_{\mathbf{k}'} V_{\mathbf{k}\mathbf{k}'} \frac{\Delta_{\mathbf{k}'}}{2\sqrt{\xi_{\mathbf{k}'}^2 + \Delta_{\mathbf{k}'}^2}}. \quad (9.29)$$

This is called the *BCS gap equation* for reasons to be discussed below. When we have solved it, it is easy to obtain the original variational parameters in terms of $\Delta_{\mathbf{k}}$,

$$u_{\mathbf{k}}^2 = \frac{1}{2} \left(1 + \frac{\xi_{\mathbf{k}}}{\sqrt{\xi_{\mathbf{k}}^2 + \Delta_{\mathbf{k}}^2}} \right), \quad (9.30)$$

$$v_{\mathbf{k}}^2 = \frac{1}{2} \left(1 - \frac{\xi_{\mathbf{k}}}{\sqrt{\xi_{\mathbf{k}}^2 + \Delta_{\mathbf{k}}^2}} \right), \quad (9.31)$$

$$u_{\mathbf{k}} v_{\mathbf{k}} = \frac{\Delta_{\mathbf{k}}}{2\sqrt{\xi_{\mathbf{k}}^2 + \Delta_{\mathbf{k}}^2}}. \quad (9.32)$$

The *relative* sign of $u_{\mathbf{k}}$ and $v_{\mathbf{k}}$ is thus the sign of $\Delta_{\mathbf{k}}$. The *absolute* sign of, say, $u_{\mathbf{k}}$ is irrelevant because of the invariance of E_{BCS} under simultaneous phase rotations of $u_{\mathbf{k}}, v_{\mathbf{k}}$ (consider a phase factor of $e^{i\pi} = -1$).

For our special interaction

$$V_{\mathbf{k}\mathbf{k}'} = \begin{cases} -V_0 & \text{for } |\xi_{\mathbf{k}}|, |\xi_{\mathbf{k}'}| < \omega_D, \\ 0 & \text{otherwise,} \end{cases} \quad (9.33)$$

the BCS gap equation (9.29) becomes

$$\Delta_{\mathbf{k}} = \begin{cases} -\frac{1}{N} \sum_{\substack{\mathbf{k}' \\ |\xi_{\mathbf{k}'}| < \omega_D}} (-V_0) \frac{\Delta_{\mathbf{k}'}}{2\sqrt{\xi_{\mathbf{k}'}^2 + \Delta_{\mathbf{k}'}^2}} & \text{for } |\xi_{\mathbf{k}}| < \omega_D, \\ 0 & \text{otherwise.} \end{cases} \quad (9.34)$$

Note that the right-hand side is independent of \mathbf{k} as long as $|\xi_{\mathbf{k}}| < \omega_D$ holds. The gap equation can be solved by the ansatz

$$\Delta_{\mathbf{k}} = \begin{cases} \Delta_0 > 0 & \text{for } |\xi_{\mathbf{k}}| < \omega_D, \\ 0 & \text{otherwise.} \end{cases} \quad (9.35)$$

We obtain

$$\Delta_0 = \frac{V_0}{N} \sum_{\substack{\mathbf{k}' \\ |\xi_{\mathbf{k}'}| < \omega_D}} \frac{\Delta_0}{2\sqrt{\xi_{\mathbf{k}'}^2 + \Delta_0^2}} \quad (9.36)$$

$$\Rightarrow 1 = \frac{V_0}{N} \sum_{\substack{\mathbf{k}' \\ |\xi_{\mathbf{k}'}| < \omega_D}} \frac{1}{2\sqrt{\xi_{\mathbf{k}'}^2 + \Delta_0^2}} = V_0 \int_{-\omega_D}^{\omega_D} d\xi D(\mu + \xi) \frac{1}{2\sqrt{\xi^2 + \Delta_0^2}}, \quad (9.37)$$

where $D(\epsilon)$ is again the density of states per spin direction and per unit cell. If the density of states is approximately constant within $\pm\omega_D$ of the Fermi energy, we obtain

$$1 = V_0 D(E_F) \frac{1}{2} \int_{-\omega_D}^{\omega_D} \frac{d\xi}{\sqrt{\xi^2 + \Delta_0^2}} = V_0 D(E_F) \text{Arsinh} \frac{\omega_D}{\Delta_0} \quad (9.38)$$

$$\Rightarrow \sinh \frac{1}{V_0 D(E_F)} = \frac{\omega_D}{\Delta_0} \quad (9.39)$$

$$\Rightarrow \Delta_0 = \omega_D \frac{1}{\sinh \frac{1}{V_0 D(E_F)}}. \quad (9.40)$$

In the so-called *weak-coupling limit* of small $V_0 D(E_F)$ and thus large $1/V_0 D(E_F)$, this result simplifies to

$$\Delta_0 \cong 2\omega_D \exp\left(-\frac{1}{V_0 D(E_F)}\right). \quad (9.41)$$

Interestingly, apart from a numerical factor, the value of Δ_0 agrees with $k_B T_c$ for the Cooper instability. We will return to this observation below. The non-analyticity of the function $\Delta_0(V_0)$ means that we cannot obtain Δ_0 and thus $|\psi_{\text{BCS}}\rangle$ within perturbation theory for small V_0 .

We can now find the energy gain due to the superconducting state, i.e., the condensation energy. For this, we insert $u_{\mathbf{k}}, v_{\mathbf{k}}$ into E_{BCS} ,

$$E_{\text{BCS}} = \sum_{\mathbf{k}} 2\xi_{\mathbf{k}} \frac{1}{2} \left(1 - \frac{\xi_{\mathbf{k}}}{\sqrt{\xi_{\mathbf{k}}^2 + \Delta_{\mathbf{k}}^2}}\right) + \frac{1}{N} \sum_{\mathbf{k}\mathbf{k}'} V_{\mathbf{k}\mathbf{k}'} \frac{\Delta_{\mathbf{k}}\Delta_{\mathbf{k}'}}{4\sqrt{\xi_{\mathbf{k}}^2 + \Delta_{\mathbf{k}}^2}\sqrt{\xi_{\mathbf{k}'}^2 + \Delta_{\mathbf{k}'}^2}}. \quad (9.42)$$

We use the simple form of $V_{\mathbf{k}\mathbf{k}'}$ and assume that $D(\epsilon)$ is constant within $\pm\omega_D$ of the Fermi energy but not outside of this interval. This gives

$$\begin{aligned} E_{\text{BCS}} &= N \int_{-\infty}^{-\omega_D} d\xi D(\mu + \xi) 2\xi \\ &+ N \int_{-\omega_D}^{\omega_D} d\xi D(\mu + \xi) \xi \left(1 - \frac{\xi}{\sqrt{\xi^2 + \Delta_0^2}}\right) \\ &+ N \int_{\omega_D}^{\infty} d\xi D(\mu + \xi) \xi (1 - 1) \\ &+ N \int_{-\omega_D}^{\omega_D} d\xi \int_{-\omega_D}^{\omega_D} d\xi' D(\mu + \xi) D(\mu + \xi') (-V_0) \frac{\Delta_0^2}{4\sqrt{\xi^2 + \Delta_0^2}\sqrt{(\xi')^2 + \Delta_0^2}} \\ &\cong 2N \int_{-\infty}^{-\omega_D} d\xi D(\mu + \xi) \xi + N D(E_F) \left(-\omega_D \sqrt{\omega_D^2 + \Delta_0^2} + \Delta_0^2 \text{Arsinh} \frac{\omega_D}{\Delta_0}\right) \end{aligned}$$

$$- N V_0 D^2(E_F) \Delta_0^2 \operatorname{Arsinh}^2 \frac{\omega_D}{\Delta_0}. \quad (9.43)$$

With the gap equation

$$V_0 D(E_F) \operatorname{Arsinh} \frac{\omega_D}{\Delta_0} = 1, \quad (9.44)$$

this simplifies to

$$E_{\text{BCS}} \cong 2N \int_{-\infty}^{-\omega_D} d\xi D(\mu + \xi) \xi - N D(E_F) \omega_D \sqrt{\omega_D^2 + \Delta_0^2}. \quad (9.45)$$

The normal-state energy should be recovered for $\Delta_0 \rightarrow 0$. The energy difference is

$$\Delta E_{\text{BCS}} := E_{\text{BCS}} - E_{\text{BCS}}|_{\Delta_0 \rightarrow 0} \cong -N D(E_F) \omega_D \sqrt{\omega_D^2 + \Delta_0^2} + N D(E_F) \omega_D^2. \quad (9.46)$$

Since for weak coupling we have $\Delta_0 \ll \omega_D$, we can expand this in Δ_0/ω_D ,

$$\Delta E_{\text{BCS}} \cong -N D(E_F) \omega_D^2 \sqrt{1 + \left(\frac{\Delta_0}{\omega_D}\right)^2} + N D(E_F) \omega_D^2 \cong -\frac{1}{2} N D(E_F) \Delta_0^2. \quad (9.47)$$

The condensation-energy density is thus (counted positively)

$$e_{\text{BCS}} \cong \frac{1}{2} \frac{N}{V} D(E_F) \Delta_0^2. \quad (9.48)$$

Type-I superconductivity is destroyed if e_{BCS} equals the energy density required for magnetic-field expulsion. At $H = H_c$, this energy is $H_c^2/8\pi$, as we have seen above. We thus conclude that

$$H_c \cong \sqrt{4\pi \frac{N}{V} D(E_F) \Delta_0}. \quad (9.49)$$

This prediction of BCS theory is in reasonably good agreement with experiments for simple superconductors.

10

BCS theory

The variational ansatz of Sec. 9.2 has given us an approximation for the many-particle ground state $|\psi_{\text{BCS}}\rangle$. While this is interesting, it does not yet allow predictions of thermodynamic properties, such as the critical temperature. As a variational ansatz, it also does not provide much insight into the conceptual character of the approximation. We will now consider superconductors at non-zero temperatures within mean-field theory, which will also provide a new perspective on the BCS gap equation and on the meaning of $\Delta_{\mathbf{k}}$.

10.1 BCS mean-field theory

We start again from the Hamiltonian

$$H = \sum_{\mathbf{k}\sigma} \xi_{\mathbf{k}} c_{\mathbf{k}\sigma}^\dagger c_{\mathbf{k}\sigma} + \frac{1}{N} \sum_{\mathbf{k}\mathbf{k}'} V_{\mathbf{k}\mathbf{k}'} c_{\mathbf{k}\uparrow}^\dagger c_{-\mathbf{k},\downarrow}^\dagger c_{-\mathbf{k}',\downarrow} c_{\mathbf{k}'\uparrow}. \quad (10.1)$$

A *mean-field approximation* consists of replacing products of operators A, B according to

$$AB \cong \langle A \rangle B + A \langle B \rangle - \langle A \rangle \langle B \rangle. \quad (10.2)$$

Note that the error introduced by this replacement is

$$AB - \langle A \rangle B - A \langle B \rangle + \langle A \rangle \langle B \rangle = (A - \langle A \rangle)(B - \langle B \rangle), \quad (10.3)$$

i.e., it is of second order in the deviations of A and B from their averages. A well-known mean-field approximation is the Hartree or Stoner approximation, which for our Hamiltonian amounts to the choice $A = c_{\mathbf{k}\uparrow}^\dagger c_{\mathbf{k}'\uparrow}$, $B = c_{-\mathbf{k},\downarrow}^\dagger c_{-\mathbf{k}',\downarrow}$. However, Bardeen, Cooper, and Schrieffer realized that superconductivity can be understood with the help of a different choice, namely $A = c_{\mathbf{k}\uparrow}^\dagger c_{-\mathbf{k},\downarrow}^\dagger$, $B = c_{-\mathbf{k}',\downarrow} c_{\mathbf{k}'\uparrow}$. This leads to the mean-field BCS Hamiltonian

$$H_{\text{BCS}} = \sum_{\mathbf{k}\sigma} \xi_{\mathbf{k}} c_{\mathbf{k}\sigma}^\dagger c_{\mathbf{k}\sigma} + \frac{1}{N} \sum_{\mathbf{k}\mathbf{k}'} V_{\mathbf{k}\mathbf{k}'} \left(\langle c_{\mathbf{k}\uparrow}^\dagger c_{-\mathbf{k},\downarrow}^\dagger \rangle c_{-\mathbf{k}',\downarrow} c_{\mathbf{k}'\uparrow} + c_{\mathbf{k}\uparrow}^\dagger c_{-\mathbf{k},\downarrow}^\dagger \langle c_{-\mathbf{k}',\downarrow} c_{\mathbf{k}'\uparrow} \rangle - \langle c_{\mathbf{k}\uparrow}^\dagger c_{-\mathbf{k},\downarrow}^\dagger \rangle \langle c_{-\mathbf{k}',\downarrow} c_{\mathbf{k}'\uparrow} \rangle \right). \quad (10.4)$$

We define

$$\Delta_{\mathbf{k}} := -\frac{1}{N} \sum_{\mathbf{k}'} V_{\mathbf{k}\mathbf{k}'} \langle c_{-\mathbf{k}',\downarrow} c_{\mathbf{k}'\uparrow} \rangle \quad (10.5)$$

so that

$$\Delta_{\mathbf{k}}^* = -\frac{1}{N} \sum_{\mathbf{k}'} V_{\mathbf{k}\mathbf{k}'} \langle c_{\mathbf{k}'\uparrow}^\dagger c_{-\mathbf{k}',\downarrow}^\dagger \rangle. \quad (10.6)$$

At this point it is not obvious that the quantity $\Delta_{\mathbf{k}}$ is the same as the one introduced in Sec. 9.2 for the special case of the ground state. Since this will turn out to be the case, we nevertheless use the same symbol from the

start. We can now write

$$H_{\text{BCS}} = \sum_{\mathbf{k}\sigma} \xi_{\mathbf{k}} c_{\mathbf{k}\sigma}^\dagger c_{\mathbf{k}\sigma} - \sum_{\mathbf{k}} \Delta_{\mathbf{k}}^* c_{-\mathbf{k},\downarrow} c_{\mathbf{k}\uparrow} - \sum_{\mathbf{k}} \Delta_{\mathbf{k}} c_{\mathbf{k}\uparrow}^\dagger c_{-\mathbf{k},\downarrow}^\dagger + \text{const.} \quad (10.7)$$

The constant is irrelevant for the following derivation and is omitted from now on. Since H_{BCS} is bilinear in c, c^\dagger it describes a non-interacting effective system. But what is unusual is that H_{BCS} contains terms of the form cc and $c^\dagger c^\dagger$, which do not conserve the electron number. We thus expect that the eigenstates of H_{BCS} do not have a sharp electron number. We had already seen that the BCS ground state has this property. This is a bit strange since superpositions of states with different electron numbers are never observed (keyword: superselection rules). One can formulate the theory of superconductivity in terms of states with fixed electron number, but this formulation is cumbersome and we will not pursue it here.

To diagonalize H_{BCS} , we introduce new fermionic operators, which are linear combinations of electron creation and annihilation operators,

$$\begin{pmatrix} \gamma_{\mathbf{k}\uparrow} \\ \gamma_{-\mathbf{k},\downarrow}^\dagger \end{pmatrix} = \begin{pmatrix} u_{\mathbf{k}}^* & -v_{\mathbf{k}} \\ v_{\mathbf{k}}^* & u_{\mathbf{k}} \end{pmatrix} \begin{pmatrix} c_{\mathbf{k}\uparrow} \\ c_{-\mathbf{k},\downarrow}^\dagger \end{pmatrix}. \quad (10.8)$$

This mapping is called *Bogoliubov* (or *Bogoliubov-Valatin*) *transformation*. Again, it is not clear yet that $u_{\mathbf{k}}, v_{\mathbf{k}}$ are related to the previously introduced quantities denoted by the same symbols. For the γ to satisfy fermionic anticommutation relations, we require

$$\begin{aligned} \{\gamma_{\mathbf{k}\uparrow}, \gamma_{\mathbf{k}\uparrow}^\dagger\} &= \gamma_{\mathbf{k}\uparrow} \gamma_{\mathbf{k}\uparrow}^\dagger + \gamma_{\mathbf{k}\uparrow}^\dagger \gamma_{\mathbf{k}\uparrow} \\ &= u_{\mathbf{k}}^* u_{\mathbf{k}} c_{\mathbf{k}\uparrow} c_{\mathbf{k}\uparrow}^\dagger - u_{\mathbf{k}}^* v_{\mathbf{k}}^* c_{\mathbf{k}\uparrow} c_{-\mathbf{k},\downarrow} - v_{\mathbf{k}} u_{\mathbf{k}} c_{-\mathbf{k},\downarrow}^\dagger c_{\mathbf{k}\uparrow}^\dagger + v_{\mathbf{k}} v_{\mathbf{k}}^* c_{-\mathbf{k},\downarrow}^\dagger c_{-\mathbf{k},\downarrow} \\ &\quad + u_{\mathbf{k}} u_{\mathbf{k}}^* c_{\mathbf{k}\uparrow}^\dagger c_{\mathbf{k}\uparrow} - u_{\mathbf{k}} v_{\mathbf{k}} c_{\mathbf{k}\uparrow}^\dagger c_{-\mathbf{k},\downarrow}^\dagger - v_{\mathbf{k}}^* u_{\mathbf{k}}^* c_{-\mathbf{k},\downarrow} c_{\mathbf{k}\uparrow} + v_{\mathbf{k}}^* v_{\mathbf{k}} c_{-\mathbf{k},\downarrow} c_{-\mathbf{k},\downarrow}^\dagger \\ &= |u_{\mathbf{k}}|^2 \underbrace{\{c_{\mathbf{k}\uparrow}, c_{\mathbf{k}\uparrow}^\dagger\}}_{=1} - u_{\mathbf{k}}^* v_{\mathbf{k}}^* \underbrace{\{c_{\mathbf{k}\uparrow}, c_{-\mathbf{k},\downarrow}\}}_{=0} - v_{\mathbf{k}} u_{\mathbf{k}} \underbrace{\{c_{-\mathbf{k},\downarrow}^\dagger, c_{\mathbf{k}\uparrow}^\dagger\}}_{=0} + |v_{\mathbf{k}}|^2 \underbrace{\{c_{-\mathbf{k},\downarrow}^\dagger, c_{-\mathbf{k},\downarrow}\}}_{=1} \\ &= |u_{\mathbf{k}}|^2 + |v_{\mathbf{k}}|^2 \stackrel{!}{=} 1. \end{aligned} \quad (10.9)$$

Using this constraint, we find the inverse transformation,

$$\begin{pmatrix} c_{\mathbf{k}\uparrow} \\ c_{-\mathbf{k},\downarrow}^\dagger \end{pmatrix} = \begin{pmatrix} u_{\mathbf{k}} & v_{\mathbf{k}} \\ -v_{\mathbf{k}}^* & u_{\mathbf{k}}^* \end{pmatrix} \begin{pmatrix} \gamma_{\mathbf{k}\uparrow} \\ \gamma_{-\mathbf{k},\downarrow}^\dagger \end{pmatrix}. \quad (10.10)$$

Insertion into H_{BCS} yields

$$\begin{aligned} H_{\text{BCS}} &= \sum_{\mathbf{k}} \left\{ \xi_{\mathbf{k}} \left(u_{\mathbf{k}}^* \gamma_{\mathbf{k}\uparrow}^\dagger + v_{\mathbf{k}}^* \gamma_{-\mathbf{k},\downarrow}^\dagger \right) \left(u_{\mathbf{k}} \gamma_{\mathbf{k}\uparrow} + v_{\mathbf{k}} \gamma_{-\mathbf{k},\downarrow}^\dagger \right) + \xi_{\mathbf{k}} \left(-v_{\mathbf{k}}^* \gamma_{\mathbf{k}\uparrow} + u_{\mathbf{k}}^* \gamma_{-\mathbf{k},\downarrow}^\dagger \right) \left(-v_{\mathbf{k}} \gamma_{\mathbf{k}\uparrow}^\dagger + u_{\mathbf{k}} \gamma_{-\mathbf{k},\downarrow} \right) \right. \\ &\quad \left. - \Delta_{\mathbf{k}}^* \left(-v_{\mathbf{k}} \gamma_{\mathbf{k}\uparrow}^\dagger + u_{\mathbf{k}} \gamma_{-\mathbf{k},\downarrow} \right) \left(u_{\mathbf{k}} \gamma_{\mathbf{k}\uparrow} + v_{\mathbf{k}} \gamma_{-\mathbf{k},\downarrow}^\dagger \right) - \Delta_{\mathbf{k}} \left(u_{\mathbf{k}}^* \gamma_{\mathbf{k}\uparrow}^\dagger + v_{\mathbf{k}}^* \gamma_{-\mathbf{k},\downarrow}^\dagger \right) \left(-v_{\mathbf{k}}^* \gamma_{\mathbf{k}\uparrow} + u_{\mathbf{k}}^* \gamma_{-\mathbf{k},\downarrow}^\dagger \right) \right\} \\ &= \sum_{\mathbf{k}} \left\{ \left(\xi_{\mathbf{k}} |u_{\mathbf{k}}|^2 - \xi_{\mathbf{k}} |v_{\mathbf{k}}|^2 + \Delta_{\mathbf{k}}^* v_{\mathbf{k}} u_{\mathbf{k}} + \Delta_{\mathbf{k}} u_{\mathbf{k}}^* v_{\mathbf{k}}^* \right) \gamma_{\mathbf{k}\uparrow}^\dagger \gamma_{\mathbf{k}\uparrow} \right. \\ &\quad + \left(-\xi_{\mathbf{k}} |v_{\mathbf{k}}|^2 + \xi_{\mathbf{k}} |u_{\mathbf{k}}|^2 + \Delta_{\mathbf{k}}^* u_{\mathbf{k}} v_{\mathbf{k}} + \Delta_{\mathbf{k}} v_{\mathbf{k}}^* u_{\mathbf{k}}^* \right) \gamma_{-\mathbf{k},\downarrow}^\dagger \gamma_{-\mathbf{k},\downarrow} \\ &\quad + \underbrace{\left(\xi_{\mathbf{k}} u_{\mathbf{k}}^* v_{\mathbf{k}} + \xi_{\mathbf{k}} u_{\mathbf{k}}^* v_{\mathbf{k}} + \Delta_{\mathbf{k}}^* v_{\mathbf{k}}^2 - \Delta_{\mathbf{k}} (u_{\mathbf{k}}^*)^2 \right)}_{=2 \xi_{\mathbf{k}} u_{\mathbf{k}}^* v_{\mathbf{k}}} \gamma_{\mathbf{k}\uparrow}^\dagger \gamma_{-\mathbf{k},\downarrow}^\dagger \\ &\quad \left. + \underbrace{\left(\xi_{\mathbf{k}} v_{\mathbf{k}}^* u_{\mathbf{k}} + \xi_{\mathbf{k}} v_{\mathbf{k}}^* u_{\mathbf{k}} - \Delta_{\mathbf{k}}^* u_{\mathbf{k}}^2 + \Delta_{\mathbf{k}} (v_{\mathbf{k}}^*)^2 \right)}_{=2 \xi_{\mathbf{k}} v_{\mathbf{k}}^* u_{\mathbf{k}}} \gamma_{-\mathbf{k},\downarrow} \gamma_{\mathbf{k}\uparrow} \right\} + \text{const.} \end{aligned} \quad (10.11)$$

The coefficients $u_{\mathbf{k}}, v_{\mathbf{k}}$ should now be chosen such that the $\gamma\gamma$ and $\gamma^\dagger\gamma^\dagger$ terms vanish. This requires

$$2\xi_{\mathbf{k}} u_{\mathbf{k}}^* v_{\mathbf{k}} + \Delta_{\mathbf{k}}^* v_{\mathbf{k}}^2 - \Delta_{\mathbf{k}} (u_{\mathbf{k}}^*)^2 = 0 \quad (10.12)$$

for the $\gamma^\dagger \gamma^\dagger$ term and the condition for $\gamma\gamma$ is redundant. Writing

$$\Delta_{\mathbf{k}} = |\Delta_{\mathbf{k}}| e^{i\phi_{\mathbf{k}}}, \quad (10.13)$$

$$u_{\mathbf{k}} = |u_{\mathbf{k}}| e^{i\alpha_{\mathbf{k}}}, \quad (10.14)$$

$$v_{\mathbf{k}} = |v_{\mathbf{k}}| e^{i\beta_{\mathbf{k}}}, \quad (10.15)$$

we obtain

$$2\xi_{\mathbf{k}} |u_{\mathbf{k}}| |v_{\mathbf{k}}| e^{i(\beta_{\mathbf{k}} - \alpha_{\mathbf{k}})} + |\Delta_{\mathbf{k}}| \left(|v_{\mathbf{k}}|^2 e^{i(2\beta_{\mathbf{k}} - \phi_{\mathbf{k}})} - |u_{\mathbf{k}}|^2 e^{i(\phi_{\mathbf{k}} - 2\alpha_{\mathbf{k}})} \right) = 0. \quad (10.16)$$

A special solution of this equation (we do not require the general solution) is given by

$$\alpha_{\mathbf{k}} = 0, \quad (10.17)$$

$$\beta_{\mathbf{k}} = \phi_{\mathbf{k}}, \quad (10.18)$$

$$2\xi_{\mathbf{k}} |u_{\mathbf{k}}| |v_{\mathbf{k}}| + |\Delta_{\mathbf{k}}| \left(|v_{\mathbf{k}}|^2 - |u_{\mathbf{k}}|^2 \right) = 0. \quad (10.19)$$

From the last equation we obtain

$$4\xi_{\mathbf{k}}^2 |u_{\mathbf{k}}|^2 |v_{\mathbf{k}}|^2 = |\Delta_{\mathbf{k}}|^2 \left(|v_{\mathbf{k}}|^4 - 2|v_{\mathbf{k}}|^2 |u_{\mathbf{k}}|^2 + |u_{\mathbf{k}}|^4 \right) \quad (10.20)$$

$$\Rightarrow 4 \left(\xi_{\mathbf{k}}^2 + |\Delta_{\mathbf{k}}|^2 \right) |u_{\mathbf{k}}|^2 |v_{\mathbf{k}}|^2 = |\Delta_{\mathbf{k}}|^2 \left(|v_{\mathbf{k}}|^4 + 2|v_{\mathbf{k}}|^2 |u_{\mathbf{k}}|^2 + |u_{\mathbf{k}}|^4 \right) = |\Delta_{\mathbf{k}}|^2 \left(|v_{\mathbf{k}}|^2 + |u_{\mathbf{k}}|^2 \right)^2 = |\Delta_{\mathbf{k}}|^2 \quad (10.21)$$

$$\Rightarrow |u_{\mathbf{k}}| |v_{\mathbf{k}}| = \frac{|\Delta_{\mathbf{k}}|}{2\sqrt{\xi_{\mathbf{k}}^2 + |\Delta_{\mathbf{k}}|^2}} \quad (10.22)$$

so that

$$|u_{\mathbf{k}}|^2 - |v_{\mathbf{k}}|^2 = \frac{2\xi_{\mathbf{k}} |u_{\mathbf{k}}| |v_{\mathbf{k}}|}{|\Delta_{\mathbf{k}}|} = \frac{\xi_{\mathbf{k}}}{\sqrt{\xi_{\mathbf{k}}^2 + |\Delta_{\mathbf{k}}|^2}}. \quad (10.23)$$

Together with $|u_{\mathbf{k}}|^2 + |v_{\mathbf{k}}|^2 = 1$ we thus find

$$|u_{\mathbf{k}}|^2 = \frac{1}{2} \left(1 + \frac{\xi_{\mathbf{k}}}{\sqrt{\xi_{\mathbf{k}}^2 + |\Delta_{\mathbf{k}}|^2}} \right), \quad (10.24)$$

$$|v_{\mathbf{k}}|^2 = \frac{1}{2} \left(1 - \frac{\xi_{\mathbf{k}}}{\sqrt{\xi_{\mathbf{k}}^2 + |\Delta_{\mathbf{k}}|^2}} \right). \quad (10.25)$$

Restoring the phases in Eq. (10.22), we also conclude that

$$u_{\mathbf{k}} v_{\mathbf{k}} = \frac{\Delta_{\mathbf{k}}}{2\sqrt{\xi_{\mathbf{k}}^2 + |\Delta_{\mathbf{k}}|^2}}. \quad (10.26)$$

$\Delta_{\mathbf{k}}$, $u_{\mathbf{k}}$, and $v_{\mathbf{k}}$ need not be real¹ but if they are, these relations are the same as in Sec. 9.2 for the BCS ground state.

The BCS Hamiltonian now reads, ignoring a constant,

$$\begin{aligned} H_{\text{BCS}} &= \sum_{\mathbf{k}} \left(\frac{\xi_{\mathbf{k}}^2}{\sqrt{\xi_{\mathbf{k}}^2 + |\Delta_{\mathbf{k}}|^2}} + \frac{|\Delta_{\mathbf{k}}|^2}{\sqrt{\xi_{\mathbf{k}}^2 + |\Delta_{\mathbf{k}}|^2}} \right) \left(\gamma_{\mathbf{k}\uparrow}^\dagger \gamma_{\mathbf{k}\uparrow} + \gamma_{-\mathbf{k},\downarrow}^\dagger \gamma_{-\mathbf{k},\downarrow} \right) \\ &= \sum_{\mathbf{k}} \sqrt{\xi_{\mathbf{k}}^2 + |\Delta_{\mathbf{k}}|^2} \left(\gamma_{\mathbf{k}\uparrow}^\dagger \gamma_{\mathbf{k}\uparrow} + \gamma_{-\mathbf{k},\downarrow}^\dagger \gamma_{-\mathbf{k},\downarrow} \right). \end{aligned} \quad (10.27)$$

¹ $u_{\mathbf{k}}$ was chosen real in the specific solution but this was not necessary.

Using $\xi_{-\mathbf{k}} = \xi_{\mathbf{k}}$ and the plausible assumption $|\Delta_{-\mathbf{k}}| = |\Delta_{\mathbf{k}}|$, both based on time-reversal symmetry, we obtain the simple form

$$H_{\text{BCS}} = \sum_{\mathbf{k}\sigma} E_{\mathbf{k}} \gamma_{\mathbf{k}\sigma}^\dagger \gamma_{\mathbf{k}\sigma} \quad (10.28)$$

with the dispersion

$$E_{\mathbf{k}} := \sqrt{\xi_{\mathbf{k}}^2 + |\Delta_{\mathbf{k}}|^2}. \quad (10.29)$$

It is instructive to first consider the normal state, for which $\Delta_{\mathbf{k}} \rightarrow 0$. Then

$$|u_{\mathbf{k}}|^2 = \frac{1}{2} \left(1 + \frac{\xi_{\mathbf{k}}}{|\xi_{\mathbf{k}}|} \right) = \begin{cases} 0 & \text{for } \xi_{\mathbf{k}} < 0, \\ 1 & \text{for } \xi_{\mathbf{k}} > 0, \end{cases} \quad (10.30)$$

$$|v_{\mathbf{k}}|^2 = \frac{1}{2} \left(1 - \frac{\xi_{\mathbf{k}}}{|\xi_{\mathbf{k}}|} \right) = \begin{cases} 1 & \text{for } \xi_{\mathbf{k}} < 0, \\ 0 & \text{for } \xi_{\mathbf{k}} > 0. \end{cases} \quad (10.31)$$

It follows that $\gamma_{\mathbf{k}\sigma} \propto c_{-\mathbf{k},-\sigma}^\dagger$ for $\xi_{\mathbf{k}} < 0$, whereas $\gamma_{\mathbf{k}\sigma} \propto c_{\mathbf{k}\sigma}$ or $\xi_{\mathbf{k}} > 0$. Hence, the Bogoliubov quasiparticles described by γ, γ^\dagger , are *holes* for energies below the chemical potential ($\xi_{\mathbf{k}} < 0$) and *electrons* for energies above ($\xi_{\mathbf{k}} > 0$). Their dispersion is $E_{\mathbf{k}} = |\xi_{\mathbf{k}}|$. For a parabolic normal dispersion $\xi_{\mathbf{k}}$:

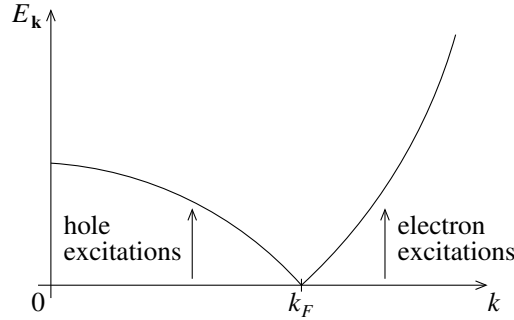

Here, $k_F = \sqrt{2m\mu}$. The excitation energies $E_{\mathbf{k}}$ are always *positive* except at the Fermi surface—it costs energy to create a hole in the Fermi sea and also to insert an electron into an empty state outside of the Fermi sea.

Superconductivity changes the dispersion to $E_{\mathbf{k}} = \sqrt{\xi_{\mathbf{k}}^2 + |\Delta_{\mathbf{k}}|^2}$:

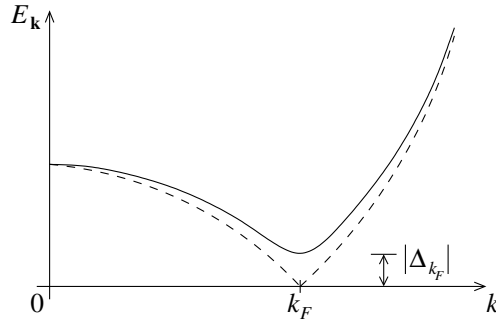

Superconductivity evidently opens an *energy gap* of magnitude $|\Delta_{k_F}|$ in the excitation spectrum.

We should recall that in deriving H_{BCS} we have ignored a constant, which we now reinsert,

$$H_{\text{BCS}} = E_{\text{BCS}} + \sum_{\mathbf{k}\sigma} E_{\mathbf{k}} \gamma_{\mathbf{k}\sigma}^\dagger \gamma_{\mathbf{k}\sigma}. \quad (10.32)$$

The energy of the system is E_{BCS} if no quasiparticles are present and is increased (by at least $|\Delta_{k_F}|$) if quasiparticles are excited. The state without any quasiparticles is the pure condensate. The fact that E_{BCS} depends

on temperature through $\langle c_{-\mathbf{k},\downarrow} c_{\mathbf{k}\uparrow} \rangle$ shows that the condensate is not generally the BCS ground state discussed previously. However, one can show that it coincides with the ground state in the limit $T \rightarrow 0$.

Furthermore, in the superconducting state we find $0 < |u_{\mathbf{k}}|^2 < 1$ and $0 < |v_{\mathbf{k}}|^2 < 1$, i.e., the Bogoliubov quasiparticles are superpositions of particles and holes. Deep inside the Fermi sea, the quasiparticles are mostly hole-like, while far above E_F they are mostly electron-like. But right at the Fermi surface we find, for example for spin $\sigma = \uparrow$,

$$\gamma_{\mathbf{k}\uparrow} = \frac{1}{\sqrt{2}} c_{\mathbf{k}\uparrow} - \frac{1}{\sqrt{2}} e^{i\phi_{\mathbf{k}}} c_{-\mathbf{k},\downarrow}^\dagger. \quad (10.33)$$

The quasiparticles here consist of electrons and holes with the same amplitude. This means that they are electrically neutral on average.

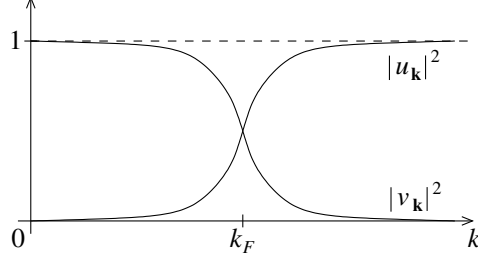

So far, we have not determined the gap function $\Delta_{\mathbf{k}}$. This can be done by inserting the Bogoliubov transformation into the definition

$$\Delta_{\mathbf{k}} = -\frac{1}{N} \sum_{\mathbf{k}'} V_{\mathbf{k}\mathbf{k}'} \langle c_{-\mathbf{k}',\downarrow} c_{\mathbf{k}'\uparrow} \rangle, \quad (10.34)$$

which yields

$$\begin{aligned} \Delta_{\mathbf{k}} &= -\frac{1}{N} \sum_{\mathbf{k}'} V_{\mathbf{k}\mathbf{k}'} \left\langle \left(-v_{\mathbf{k}'} \gamma_{\mathbf{k}'\uparrow}^\dagger + u_{\mathbf{k}'} \gamma_{-\mathbf{k}',\downarrow} \right) \left(u_{\mathbf{k}'} \gamma_{\mathbf{k}'\uparrow} + v_{\mathbf{k}'} \gamma_{-\mathbf{k}',\downarrow}^\dagger \right) \right\rangle \\ &= -\frac{1}{N} \sum_{\mathbf{k}'} V_{\mathbf{k}\mathbf{k}'} \left\{ -v_{\mathbf{k}'} u_{\mathbf{k}'} \langle \gamma_{\mathbf{k}'\uparrow}^\dagger \gamma_{\mathbf{k}'\uparrow} \rangle + u_{\mathbf{k}'} v_{\mathbf{k}'} \langle \gamma_{-\mathbf{k}',\downarrow} \gamma_{-\mathbf{k}',\downarrow}^\dagger \rangle \right. \\ &\quad \left. - v_{\mathbf{k}'}^2 \langle \gamma_{\mathbf{k}'\uparrow}^\dagger \gamma_{-\mathbf{k}',\downarrow}^\dagger \rangle + u_{\mathbf{k}'}^2 \langle \gamma_{-\mathbf{k}',\downarrow} \gamma_{\mathbf{k}'\uparrow} \rangle \right\}. \end{aligned} \quad (10.35)$$

For *selfconsistency*, the averages have to be evaluated with the BCS Hamiltonian H_{BCS} . This gives

$$\langle \gamma_{\mathbf{k}'\uparrow}^\dagger \gamma_{\mathbf{k}'\uparrow} \rangle = n_F(E_{\mathbf{k}'}), \quad (10.36)$$

$$\langle \gamma_{-\mathbf{k}',\downarrow} \gamma_{-\mathbf{k}',\downarrow}^\dagger \rangle = 1 - n_F(E_{\mathbf{k}'}), \quad (10.37)$$

$$\langle \gamma_{\mathbf{k}'\uparrow}^\dagger \gamma_{-\mathbf{k}',\downarrow}^\dagger \rangle = 0, \quad (10.38)$$

$$\langle \gamma_{-\mathbf{k}',\downarrow} \gamma_{\mathbf{k}'\uparrow} \rangle = 0, \quad (10.39)$$

and we obtain the *BCS gap equation*, now at arbitrary temperature,

$$\begin{aligned} \Delta_{\mathbf{k}} &= -\frac{1}{N} \sum_{\mathbf{k}'} V_{\mathbf{k}\mathbf{k}'} u_{\mathbf{k}'} v_{\mathbf{k}'} [1 - 2n_F(E_{\mathbf{k}'})] \\ &= -\frac{1}{N} \sum_{\mathbf{k}'} V_{\mathbf{k}\mathbf{k}'} \frac{\Delta_{\mathbf{k}'}}{2\sqrt{\xi_{\mathbf{k}'}^2 + |\Delta_{\mathbf{k}'}|^2}} [1 - 2n_F(E_{\mathbf{k}'})] \\ &\equiv -\frac{1}{N} \sum_{\mathbf{k}'} V_{\mathbf{k}\mathbf{k}'} \frac{\Delta_{\mathbf{k}'}}{2E_{\mathbf{k}'}} [1 - 2n_F(E_{\mathbf{k}'})]. \end{aligned} \quad (10.40)$$

We see that $n_F(E_{\mathbf{k}'}) \rightarrow 0$ for $E_{\mathbf{k}'} > 0$ and $T \rightarrow 0$ so that the zero-temperature BCS gap equation (9.29) is recovered as a limiting case.

For the simplified model interaction given by Eq. (9.19) and assuming a \mathbf{k} -independent real gap, we obtain, in analogy to the ground-state derivation,

$$1 = V_0 \int_{-\omega_D}^{\omega_D} d\xi D(\mu + \xi) \frac{1 - 2n_F(\sqrt{\xi^2 + \Delta_0^2})}{2\sqrt{\xi^2 + \Delta_0^2}} = V_0 \int_{-\omega_D}^{\omega_D} d\xi D(\mu + \xi) \frac{\tanh \frac{\beta}{2} \sqrt{\xi^2 + \Delta_0^2}}{2\sqrt{\xi^2 + \Delta_0^2}}. \quad (10.41)$$

Note that this only works for $\Delta_0 \neq 0$ since we have divided by Δ_0 . If the density of states is approximately constant close to E_F , the equation simplifies to

$$1 \cong V_0 D(E_F) \int_{-\omega_D}^{\omega_D} d\xi \frac{\tanh \frac{\beta}{2} \sqrt{\xi^2 + \Delta_0^2}}{2\sqrt{\xi^2 + \Delta_0^2}}. \quad (10.42)$$

This equation can be solved numerically—the numerically evaluated integral needs to be plugged into a numerical root finder—leading to the temperature dependence of Δ_0 :

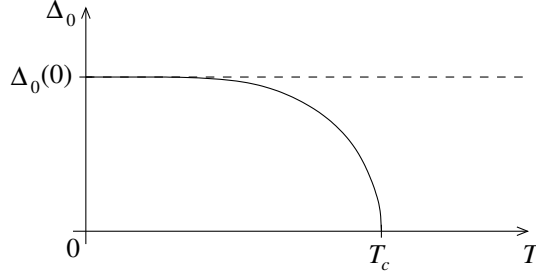

For weak coupling we have already seen that

$$\Delta_0(0) \cong 2\omega_D \exp\left(-\frac{1}{V_0 D(E_F)}\right). \quad (10.43)$$

We can also obtain an analytical expression for T_c : If T approaches T_c from below, we can take the limit $\Delta_0 \rightarrow 0$ in the gap equation. This leads to the *linearized gap equation*

$$\begin{aligned} 1 &\cong V_0 D(E_F) \int_{-\omega_D}^{\omega_D} d\xi \frac{\tanh \frac{\beta}{2} |\xi|}{2|\xi|} \\ &= V_0 D(E_F) \int_0^{\omega_D} d\xi \frac{\tanh \frac{\beta}{2} \xi}{\xi} \\ &= V_0 D(E_F) \int_0^{\beta\omega_D/2} dx \frac{\tanh x}{x} \\ &\stackrel{\text{by parts}}{=} V_0 D(E_F) \left\{ \ln \frac{\beta\omega_D}{2} \tanh \frac{\beta\omega_D}{2} - \int_0^{\beta\omega_D/2} dx \frac{\ln x}{\cosh^2 x} \right\}. \end{aligned} \quad (10.44)$$

In the weak-coupling limit we have $\beta\omega_D = \omega_D/k_B T \gg 1$ (this assertion should be checked *a-posteriori*). Since the integrand of the last integral decays exponentially for large x , we can send the upper limit to infinity,

$$1 \cong V_0 D(E_F) \left\{ \ln \frac{\beta\omega_D}{2} \underbrace{\tanh \frac{\beta\omega_D}{2}}_{\cong 1} - \int_0^{\infty} dx \frac{\ln x}{\cosh^2 x} \right\} \cong V_0 D(E_F) \left(\ln \frac{\beta\omega_D}{2} + \gamma - \ln \frac{\pi}{4} \right), \quad (10.45)$$

where γ is again the Euler gamma constant. This implies

$$\exp\left(\frac{1}{V_0 D(E_F)}\right) \cong \frac{2\beta\omega_D}{\pi} e^\gamma \quad (10.46)$$

$$\Rightarrow k_B T_c \cong \frac{2e^\gamma}{\pi} \omega_D \exp\left(-\frac{1}{V_0 D(E_F)}\right). \quad (10.47)$$

This is exactly the same expression we have found above for the critical temperature of the Cooper instability in Sec. 9.1. Since the approximations used are quite different, this agreement is not trivial. The gap at zero temperature and the critical temperature thus have a *universal* ratio in BCS theory,

$$\frac{2\Delta_0(0)}{k_B T_c} \cong \frac{2\pi}{e^\gamma} \approx 3.528. \quad (10.48)$$

This ratio is close to the result measured for simple elemental superconductors. For example, for tin one finds $2\Delta_0(0)/k_B T_c \approx 3.46$. For superconductors with stonger coupling, such as mercury, and for unconventional superconductors the agreement is not good, though. In part, this is due to the crude model for the (temperature-independent) interaction, not so much to a failure of the mean-field approximation.

10.2 Minimization of the free energy

In the previous section, we have obtained the BCS state by decoupling the interaction in the ‘‘Cooper channel,’’ leading to Eq. (10.4), and choosing averages such as $\langle c_{\mathbf{k}\uparrow}^\dagger c_{-\mathbf{k},\downarrow}^\dagger \rangle$ selfconsistently. The state so obtained is the one that minimizes the free energy, which is surely the right thing to do. It also gives a hint that BCS theory is consistent with Landau theory. We will return to this point below. In this section, we derive the BCS state by minimizing the free energy explicitly.

We consider a constant attractive interaction $V = -V_0$ with high-energy cutoff Λ , see Eq. (9.19). Above, this was the Debye energy. We continue to assume that $\Delta_{\mathbf{k}} = \Delta$ is momentum independent and use this assumption from the start by writing

$$\Delta = \frac{V_0}{N} \sum_{\mathbf{k}} \langle c_{-\mathbf{k},\downarrow} c_{\mathbf{k}\uparrow} \rangle, \quad (10.49)$$

$$\Delta^* = \frac{V_0}{N} \sum_{\mathbf{k}} \langle c_{\mathbf{k}\uparrow}^\dagger c_{-\mathbf{k},\downarrow}^\dagger \rangle. \quad (10.50)$$

In the derivation of the free energy, it is crucial to keep all energy contributions. The BCS Hamiltonian of Eq. (10.4) now reads

$$\begin{aligned} H_{\text{BCS}} &= \sum_{\mathbf{k}\sigma} \xi_{\mathbf{k}} c_{\mathbf{k}\sigma}^\dagger c_{\mathbf{k}\sigma} - \sum_{\mathbf{k}} \Delta^* c_{-\mathbf{k},\downarrow} c_{\mathbf{k}\uparrow} - \sum_{\mathbf{k}} \Delta c_{\mathbf{k}\uparrow}^\dagger c_{-\mathbf{k},\downarrow}^\dagger + \frac{V_0}{N} \left(-\frac{N}{V_0} \Delta^*\right) \left(-\frac{N}{V_0} \Delta\right) \\ &= \sum_{\mathbf{k}\sigma} \xi_{\mathbf{k}} c_{\mathbf{k}\sigma}^\dagger c_{\mathbf{k}\sigma} - \sum_{\mathbf{k}} \Delta^* c_{-\mathbf{k},\downarrow} c_{\mathbf{k}\uparrow} - \sum_{\mathbf{k}} \Delta c_{\mathbf{k}\uparrow}^\dagger c_{-\mathbf{k},\downarrow}^\dagger + N \frac{\Delta^* \Delta}{V_0}. \end{aligned} \quad (10.51)$$

The terms containing operators can usefully be written in terms of two-component (‘‘Nambu-spinor’’) operators

$$\Psi_{\mathbf{k}} := \begin{pmatrix} c_{\mathbf{k},\uparrow} \\ c_{-\mathbf{k},\downarrow}^\dagger \end{pmatrix}, \quad \Psi_{\mathbf{k}}^\dagger = \begin{pmatrix} c_{\mathbf{k}\uparrow}^\dagger & c_{-\mathbf{k},\downarrow} \end{pmatrix}. \quad (10.52)$$

Note that the spinors each contain a creation and an annihilation operator. We rewrite the normal part of the Hamiltonian as

$$\sum_{\mathbf{k}\sigma} \xi_{\mathbf{k}} c_{\mathbf{k}\sigma}^\dagger c_{\mathbf{k}\sigma} = \sum_{\mathbf{k}} \xi_{\mathbf{k}} c_{\mathbf{k}\uparrow}^\dagger c_{\mathbf{k}\uparrow} + \sum_{\mathbf{k}} \xi_{\mathbf{k}} c_{\mathbf{k}\downarrow}^\dagger c_{\mathbf{k}\downarrow}$$

$$\begin{aligned}
&= \sum_{\mathbf{k}} \xi_{\mathbf{k}} c_{\mathbf{k}\uparrow}^\dagger c_{\mathbf{k}\uparrow} + \sum_{\mathbf{k}} \underbrace{\xi_{-\mathbf{k}}}_{=\xi_{\mathbf{k}}} c_{-\mathbf{k},\downarrow}^\dagger c_{-\mathbf{k},\downarrow} \\
&= \sum_{\mathbf{k}} \xi_{\mathbf{k}} c_{\mathbf{k}\uparrow}^\dagger c_{\mathbf{k}\uparrow} - \sum_{\mathbf{k}} \xi_{\mathbf{k}} c_{-\mathbf{k},\downarrow} c_{-\mathbf{k},\downarrow}^\dagger + \sum_{\mathbf{k}} \xi_{\mathbf{k}}.
\end{aligned} \tag{10.53}$$

This allows us to write

$$H_{\text{BCS}} = \sum_{\mathbf{k}} \Psi_{\mathbf{k}}^\dagger \begin{pmatrix} \xi_{\mathbf{k}} & -\Delta \\ -\Delta^* & -\xi_{\mathbf{k}} \end{pmatrix} \Psi_{\mathbf{k}} + \sum_{\mathbf{k}} \xi_{\mathbf{k}} + \frac{N}{V_0} |\Delta|^2. \tag{10.54}$$

The term $\sum_{\mathbf{k}} \xi_{\mathbf{k}}$ is a constant energy that does not depend on the gap parameter Δ and can thus be dropped when we determine Δ . The next step is to diagonalize the 2×2 matrices. Here, we only need the eigenvalues. We do not require the eigenvectors, or, equivalently, the explicit unitary transformation. Of course, this is just the Bogoliubov transformation discussed above. We introduce

$$\Gamma_{\mathbf{k}} := \begin{pmatrix} \gamma_{\mathbf{k},\uparrow} \\ \gamma_{-\mathbf{k},\downarrow}^\dagger \end{pmatrix}, \quad \Gamma_{\mathbf{k}}^\dagger = \begin{pmatrix} \gamma_{\mathbf{k}\uparrow}^\dagger, \gamma_{-\mathbf{k},\downarrow} \end{pmatrix}. \tag{10.55}$$

and obtain

$$\begin{aligned}
H_{\text{BCS}} &= \sum_{\mathbf{k}} \Gamma_{\mathbf{k}}^\dagger \begin{pmatrix} \sqrt{\xi_{\mathbf{k}}^2 + |\Delta|^2} & 0 \\ 0 & -\sqrt{\xi_{\mathbf{k}}^2 + |\Delta|^2} \end{pmatrix} \Gamma_{\mathbf{k}} + \frac{N}{V_0} |\Delta|^2 \\
&= \sum_{\mathbf{k}\sigma} \sqrt{\xi_{\mathbf{k}}^2 + |\Delta|^2} \gamma_{\mathbf{k}\sigma}^\dagger \gamma_{\mathbf{k}\sigma} - \sum_{\mathbf{k}} \sqrt{\xi_{\mathbf{k}}^2 + |\Delta|^2} + \frac{N}{V_0} |\Delta|^2.
\end{aligned} \tag{10.56}$$

Since the quasiparticles do not interact in the BCS approximation the partition function can be written as a product:

$$\begin{aligned}
Z &= \exp\left(-\beta \frac{N}{V_0} |\Delta|^2\right) \exp\left(\beta \sum_{\mathbf{k}} \sqrt{\xi_{\mathbf{k}}^2 + |\Delta|^2}\right) \prod_{\mathbf{k}\sigma} \left[1 + \exp\left(-\beta \sqrt{\xi_{\mathbf{k}}^2 + |\Delta|^2}\right)\right] \\
&= \exp\left(-\beta \frac{N}{V_0} |\Delta|^2\right) \prod_{\mathbf{k}} \exp\left(\beta \sqrt{\xi_{\mathbf{k}}^2 + |\Delta|^2}\right) \left[1 + \exp\left(-\beta \sqrt{\xi_{\mathbf{k}}^2 + |\Delta|^2}\right)\right]^2 \\
&= \exp\left(-\beta \frac{N}{V_0} |\Delta|^2\right) \prod_{\mathbf{k}} \left[\exp\left(\frac{\beta \sqrt{\xi_{\mathbf{k}}^2 + |\Delta|^2}}{2}\right) + \exp\left(-\frac{\beta \sqrt{\xi_{\mathbf{k}}^2 + |\Delta|^2}}{2}\right)\right]^2 \\
&= \exp\left(-\beta \frac{N}{V_0} |\Delta|^2\right) \prod_{\mathbf{k}} 4 \cosh^2 \frac{\beta \sqrt{\xi_{\mathbf{k}}^2 + |\Delta|^2}}{2} \\
&= 4^N \exp\left(-\beta \frac{N}{V_0} |\Delta|^2\right) \prod_{\mathbf{k}} \cosh^2 \frac{\beta E_{\mathbf{k}}}{2},
\end{aligned} \tag{10.57}$$

with $E_{\mathbf{k}} = \sqrt{\xi_{\mathbf{k}}^2 + |\Delta|^2}$. Strictly speaking, this is the grand-canonical partition function, which is not obvious since the chemical potential μ is hidden in $\xi_{\mathbf{k}} = \epsilon_{\mathbf{k}} - \mu$. The free energy (or more correctly the grand potential) is then

$$\begin{aligned}
F &= -k_B T \ln Z = -N k_B T \ln 4 + \frac{N}{V_0} |\Delta|^2 - k_B T \sum_{\mathbf{k}} \ln \cosh^2 \frac{\beta E_{\mathbf{k}}}{2} \\
&= -2N k_B T \ln 2 + \frac{N}{V_0} |\Delta|^2 - 2k_B T \sum_{\mathbf{k}} \ln \cosh \frac{\beta E_{\mathbf{k}}}{2}.
\end{aligned} \tag{10.58}$$

Note that we could now expand F in powers of Δ . In this way, we can derive a Landau theory for the superconducting order parameter from the microscopic Hamiltonian. By allowing for the mean-field solution Δ to depend

on space and performing the same steps, we can, in principle, also derive the Ginzburg-Landau theory. Here, we do not perform any expansion, though.

It is useful to obtain the limit for $T \rightarrow 0$:

$$\begin{aligned}\lim_{T \rightarrow 0} F &= \frac{N}{V_0} |\Delta|^2 - \lim_{T \rightarrow 0} 2k_B T \sum_{\mathbf{k}} \ln \frac{e^{\beta E_{\mathbf{k}}/2}}{2} \\ &= \frac{N}{V_0} |\Delta|^2 - \lim_{T \rightarrow 0} 2k_B T \sum_{\mathbf{k}} \frac{E_{\mathbf{k}}}{2k_B T} \\ &= - \sum_{\mathbf{k}} E_{\mathbf{k}} + \frac{N}{V_0} |\Delta|^2.\end{aligned}\tag{10.59}$$

This agrees with Eq. (10.56): At zero temperature, none of the quasiparticle states is occupied since they all have positive energies $E_{\mathbf{k}} > 0$. The limit $T \rightarrow 0$, the free energy is of course identical to the internal energy U . We can now double check that the normal-state limit is correct. To that end, we have to restore the term $\sum_{\mathbf{k}} \xi_{\mathbf{k}}$ from Eq. (10.54):

$$U = - \sum_{\mathbf{k}} E_{\mathbf{k}} + \sum_{\mathbf{k}} \xi_{\mathbf{k}} + \frac{N}{V_0} |\Delta|^2.\tag{10.60}$$

In the normal state, $\Delta = 0$, $E_{\mathbf{k}} = \sqrt{\xi_{\mathbf{k}}^2} = |\xi_{\mathbf{k}}|$, and thus

$$U = \sum_{\mathbf{k}} (\xi_{\mathbf{k}} - |\xi_{\mathbf{k}}|) = 2 \sum_{\mathbf{k} | \xi_{\mathbf{k}} < 0} \xi_{\mathbf{k}}.\tag{10.61}$$

This is indeed correct. The factor 2 results from the spin degeneracy of bands in our simple model.

The BCS gap equation is obtained by minimizing F with respect to $|\Delta|$:

$$\begin{aligned}0 &\stackrel{!}{=} \frac{dF}{d|\Delta|} = \frac{2N}{V_0} |\Delta| - 2k_B T \sum_{\mathbf{k}} \frac{\sinh \frac{\beta E_{\mathbf{k}}}{2}}{\cosh \frac{\beta E_{\mathbf{k}}}{2}} \frac{d}{d|\Delta|} \frac{dE_{\mathbf{k}}}{2} \\ &= \frac{2N}{V_0} |\Delta| - \sum_{\mathbf{k}} \tanh \frac{\beta E_{\mathbf{k}}}{2} \frac{d}{d|\Delta|} \sqrt{\xi_{\mathbf{k}}^2 + |\Delta|^2} \\ &= \frac{2N}{V_0} |\Delta| - \sum_{\mathbf{k}} \tanh \frac{\beta E_{\mathbf{k}}}{2} \frac{|\Delta|}{\sqrt{\xi_{\mathbf{k}}^2 + |\Delta|^2}},\end{aligned}\tag{10.62}$$

which gives

$$|\Delta| = \frac{V_0}{2N} \sum_{\mathbf{k}} \frac{|\Delta|}{E_{\mathbf{k}}} \tanh \frac{\beta E_{\mathbf{k}}}{2}.\tag{10.63}$$

With

$$\tanh \frac{\beta E_{\mathbf{k}}}{2} = \frac{e^{\beta E_{\mathbf{k}}/2} - e^{-\beta E_{\mathbf{k}}/2}}{e^{\beta E_{\mathbf{k}}/2} + e^{-\beta E_{\mathbf{k}}/2}} = \frac{e^{\beta E_{\mathbf{k}}} - 1}{e^{\beta E_{\mathbf{k}}} + 1} = \frac{e^{\beta E_{\mathbf{k}}} + 1 - 2}{e^{\beta E_{\mathbf{k}}} + 1} = 1 - \frac{2}{e^{\beta E_{\mathbf{k}}} + 1} = 1 - 2n_F(E_{\mathbf{k}})\tag{10.64}$$

we obtain

$$|\Delta| = \frac{V_0}{2N} \sum_{\mathbf{k}} \frac{|\Delta|}{E_{\mathbf{k}}} [1 - 2n_F(E_{\mathbf{k}})],\tag{10.65}$$

which is the BCS gap equation of the last section, for the special case of constant V and Δ . Hence, the two approaches are equivalent, as they should be.

Now let us look at the free energy more closely. We consider a parabolic band structure $\xi_{\mathbf{k}} = k^2/2m - \mu$ but the essential results do not depend on this. Our goal is to identify the leading dependence on $|\Delta|$. Dropping a $|\Delta|$ -independent term, we obtain from Eq. (10.58),

$$F = \frac{N}{V_0} |\Delta|^2 - 2k_B T \sum_{\mathbf{k}} \ln \cosh \frac{\beta E_{\mathbf{k}}}{2}$$

$$\begin{aligned}
&= \frac{N}{V_0} |\Delta|^2 - 2k_B T N v_{\text{uc}} \int \frac{d^3 k}{(2\pi)^3} \ln \cosh \frac{\beta E_{\mathbf{k}}}{2} \quad \Big| \quad v_{\text{uc}} \text{ is the volume of the primitive unit cell} \\
&= \frac{N}{V_0} |\Delta|^2 - 2k_B T N v_{\text{uc}} \frac{1}{2\pi^2} \int dk k^2 \ln \cosh \frac{\beta E_{\mathbf{k}}}{2}.
\end{aligned} \tag{10.66}$$

Substituting $\epsilon = k^2/2m$, we get $k = \sqrt{2m\epsilon}$ and thus

$$F = \frac{N}{V_0} |\Delta|^2 - \frac{k_B T N v_{\text{uc}}}{\pi^2} (2m)^{3/2} \frac{1}{2} \int_0^\Lambda d\epsilon \sqrt{\epsilon} \ln \cosh \frac{\beta}{2} \sqrt{(\epsilon - \mu)^2 + |\Delta|^2}, \tag{10.67}$$

where we have made the cutoff Λ explicit. Now comes a subtle point: while the free energy is dominated by contributions from energies ϵ far from the chemical potential (for such ϵ the integrand is large), the strongest $|\Delta|$ dependence results from ϵ close to μ . This is plausible: only if $(\epsilon - \mu)^2$ under the root is small can $|\Delta|^2$ play a significant role. Hence in evaluating the leading $|\Delta|$ dependence, we can assume $\epsilon \approx \mu$ outside of $E_{\mathbf{k}}$:

$$\begin{aligned}
F &\cong \frac{N}{V_0} |\Delta|^2 - \frac{k_B T N v_{\text{uc}} (2m)^{3/2}}{2\pi^2} \sqrt{\mu} \int_0^\Lambda d\epsilon \ln \cosh \frac{\beta}{2} \sqrt{(\epsilon - \mu)^2 + |\Delta|^2} \\
&= \frac{N}{V_0} |\Delta|^2 - \frac{k_B T N v_{\text{uc}} (2m)^{3/2}}{2\pi^2} \sqrt{\mu} \int_{-\mu}^{\Lambda - \mu} d\epsilon \ln \cosh \frac{\beta}{2} \sqrt{\epsilon^2 + |\Delta|^2}.
\end{aligned} \tag{10.68}$$

The cutoff is large compared to all other energies so that we can replace $\Lambda - \mu$ by Λ as the upper limit. Now we assume, in addition, that $\mu \gg |\Delta|$, which is the case for typical superconductors. As noted, $|\Delta|$ only plays a significant role for $|\epsilon| \lesssim |\Delta| \ll \mu$. For the leading $|\Delta|$ dependence, we can thus extend the lower limit to some value that is large in magnitude. For convenience, we use the same cutoff as for the upper limit (using different cutoffs does not lead to any new insight) and write this as

$$\begin{aligned}
F &\cong \frac{N}{V_0} |\Delta|^2 - \frac{k_B T N v_{\text{uc}} (2m)^{3/2}}{2\pi^2} \sqrt{\mu} \int_{-\Lambda}^\Lambda d\epsilon \ln \cosh \frac{\beta}{2} \sqrt{\epsilon^2 + |\Delta|^2} \\
&= \frac{N}{V_0} |\Delta|^2 - \frac{k_B T N v_{\text{uc}} (2m)^{3/2}}{\pi^2} \sqrt{\mu} \int_0^\Lambda d\epsilon \ln \cosh \frac{\beta}{2} \sqrt{\epsilon^2 + |\Delta|^2}.
\end{aligned} \tag{10.69}$$

At low temperatures $k_B T \ll |\Delta|$, the argument of the hyperbolic cosine is large compared to unity and we have

$$\ln \cosh x = \ln \frac{e^x + e^{-x}}{2} \cong \ln \frac{e^x}{2} = x - \ln 2 \cong x \tag{10.70}$$

and thus

$$\begin{aligned}
F &\cong \frac{N}{V_0} |\Delta|^2 - \frac{k_B T N v_{\text{uc}} (2m)^{3/2}}{\pi^2} \sqrt{\mu} \int_0^\Lambda d\epsilon \frac{\beta}{2} \sqrt{\epsilon^2 + |\Delta|^2} \quad \Big| \quad u = \frac{\epsilon}{|\Delta|} \\
&= \frac{N}{V_0} |\Delta|^2 - \frac{N v_{\text{uc}} (2m)^{3/2}}{\pi^2} \sqrt{\mu} \frac{|\Delta|^2}{2} \int_0^{\Lambda/|\Delta|} du \sqrt{u^2 + 1}.
\end{aligned} \tag{10.71}$$

The integral is

$$\begin{aligned}
\int_0^{\Lambda/|\Delta|} du \sqrt{u^2 + 1} &= \frac{1}{2} \left[u \sqrt{u^2 + 1} + \ln \left(u + \sqrt{u^2 + 1} \right) \right]_0^{\Lambda/|\Delta|} \\
&= \frac{1}{2} \left(\frac{\Lambda \sqrt{\Lambda^2 + |\Delta|^2}}{|\Delta|^2} + \ln \frac{\Lambda + \sqrt{\Lambda^2 + |\Delta|^2}}{|\Delta|} \right)
\end{aligned} \tag{10.72}$$

and with $\Lambda \gg |\Delta|$,

$$\dots \cong \frac{1}{2} \left(\frac{\Lambda^2}{|\Delta|^2} + \ln \frac{2\Lambda}{|\Delta|} \right) \cong \frac{1}{2} \left(\frac{\Lambda^2}{|\Delta|^2} - \ln \frac{|\Delta|}{\Lambda} \right). \tag{10.73}$$

This gives

$$\begin{aligned}
F &\cong \frac{N}{V_0} |\Delta|^2 - \frac{Nv_{\text{uc}}(2m)^{3/2}\sqrt{\mu}}{4\pi^2} \left(\Lambda^2 - |\Delta|^2 \ln \frac{|\Delta|}{\Lambda} \right) \\
&= \frac{N}{V_0} |\Delta|^2 + \frac{Nv_{\text{uc}}(2m)^{3/2}\sqrt{\mu}}{4\pi^2} |\Delta|^2 \ln \frac{|\Delta|}{\Lambda} + \text{const},
\end{aligned} \tag{10.74}$$

as far as the $|\Delta|$ dependence is concerned. The first term results from the operator-free term $\langle A \rangle \langle B \rangle$ in the general mean-field decoupling, while the second is due to the effect of the gap opening on the quasiparticle density of states. The term $\ln(|\Delta|/\Lambda)$ is called the ‘‘Cooper logarithm.’’ It is crucial for understanding the low-temperature behavior, as we discuss next.

Note that the first term, $(N/V_0) |\Delta|^2$, is positive. In the second term, the prefactor and $|\Delta|^2$ are positive but the Cooper logarithm is negative since $|\Delta| < \Lambda$. We write

$$F \cong \text{const} + N \left(\underbrace{\frac{1}{V_0}}_{>0} + \underbrace{\frac{Nv_{\text{uc}}(2m)^{3/2}\sqrt{\mu}}{4\pi^2}}_{>0} \underbrace{\ln \frac{|\Delta|}{\Lambda}}_{<0} \right) |\Delta|^2. \tag{10.75}$$

For $|\Delta| \rightarrow 0$, the logarithm diverges to $-\infty$, though very slowly. Hence, for sufficiently small $|\Delta|$, it will always overpower the constant $1/V_0$ so that the free energy initially decreases when $|\Delta|$ is increased starting from zero.

Now we consider the free energy at large $|\Delta|$. Here, we have

$$E_{\mathbf{k}} = \sqrt{\xi_{\mathbf{k}}^2 + |\Delta|^2} \cong |\Delta| \tag{10.76}$$

and the free energy of Eq. (10.58) becomes

$$F \cong -2Nk_B T \ln 2 + \frac{N}{V_0} |\Delta|^2 - 2k_B T \sum_{\mathbf{k}} \ln \cosh \frac{\beta|\Delta|}{2}. \tag{10.77}$$

Using $|\Delta| \gg k_B T$, we get

$$\begin{aligned}
F &\cong -2Nk_B T \ln 2 + \frac{N}{V_0} |\Delta|^2 - 2k_B T \sum_{\mathbf{k}} \ln \frac{e^{\beta|\Delta|/2}}{2} \\
&= \cancel{-2Nk_B T \ln 2} + \frac{N}{V_0} |\Delta|^2 - \cancel{2k_B T N} \frac{\cancel{N}|\Delta|}{2} + \cancel{2k_B T N \ln 2} \\
&= \frac{N}{V_0} |\Delta|^2 - N |\Delta|.
\end{aligned} \tag{10.78}$$

Thus the positive, quadratic term is large compared to the negative, linear one and the free energy increases with increasing gap parameter $|\Delta|$. In summary, for small $|\Delta|$, the contribution from the quasiparticle energies increases towards negative values slightly (logarithmically) faster than the term from the mean-field decoupling increases towards positive values. On the other hand, at large $|\Delta|$, the increasing decoupling term dominates over the quasiparticle contribution.

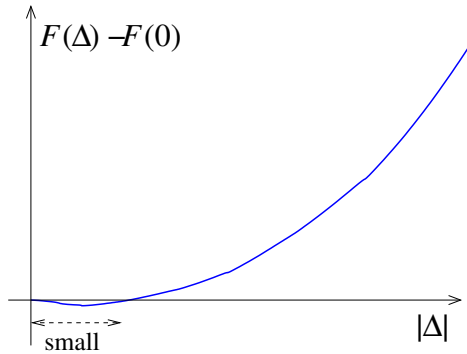

The range of $F(\Delta) - F(0) < 0$ is restricted to very small $|\Delta|$ since it relies on the *logarithm* of $|\Delta|$ being large. Nevertheless, the minimum free energy always occurs at $|\Delta| > 0$, i.e., there is always superconductivity at low temperatures when the interacting is attractive. Hence, we have recovered the *weak-coupling* nature of the instability discussed in the previous chapter. Note that we have not considered competing instabilities—the system might for example order magnetically, preventing the superconducting instability.

10.3 Richardson’s solution of the BCS model

We return to the simplified BCS Hamiltonian of Eqs. (9.18) and (9.19), repeated here:

$$H = \sum_{\mathbf{k}\sigma} \xi_{\mathbf{k}} c_{\mathbf{k}\sigma}^\dagger c_{\mathbf{k}\sigma} + \frac{1}{N} \sum_{\mathbf{k}\mathbf{k}'} V_{\mathbf{k}\mathbf{k}'} c_{\mathbf{k}\uparrow}^\dagger c_{-\mathbf{k},\downarrow}^\dagger c_{-\mathbf{k}',\downarrow} c_{\mathbf{k}'\uparrow}, \quad (10.79)$$

where

$$V_{\mathbf{k}\mathbf{k}'} = \begin{cases} -V_0 & \text{for } |\xi_{\mathbf{k}}| < \omega_D \text{ and } |\xi_{\mathbf{k}'}| < \omega_D, \\ 0 & \text{otherwise.} \end{cases} \quad (10.80)$$

The coupling $V_{\mathbf{k}\mathbf{k}'}$ is thus constant within a shell surrounding the Fermi surface and zero outside. Since ω_D is typically small compared to the chemical potential this shell is thin and we can expand the normal-state dispersion to linear order. This implies that in the direction normal to the Fermi surface, the shell extends by ω_D/v_F in momentum, where v_F is the Fermi velocity.

Above, we have solved this interacting model within the mean-field approximation. Would it not be nice to be able to go beyond this or ideally to solve the model exactly? Amazingly, this is possible, at least in the number of relevant momenta is finite. The solution goes back to Robert Richardson [R. W. Richardson, Phys. Lett. **3**, 277 (1963); see also G. Gorohovsky and E. Bettelheim, Phys. Rev. B **84**, 224503 (2011)] for an equivalent model applied to atomic nuclei. It uses a variant of the so-called Bethe ansatz. We will not present the solution here but make a few remarks.

The BCS Hamiltonian involves scattering of electron pairs with momenta \mathbf{k} and $-\mathbf{k}$. Evidently, there is no scattering and hence no interaction between electrons with \mathbf{k} outside of the thin shell. These electrons are thus free and the solution of the many-particle problem for them is trivial—the single-particle states are occupied according to the Fermi distribution. Furthermore, if a pair with momenta \mathbf{k} and $-\mathbf{k}$ is singly occupied the interaction gives zero and such electrons are also effectively free. Let us denote the number of empty and doubly occupied pairs of momenta within the shell by n_k . Richardson showed that all eigenvalues of the many-particle Hamiltonian of these $2n_k$ particles can be obtained by solving a set of n_k coupled nonlinear algebraic equations. While this is not trivial, it is much easier than diagonalizing the many-particle Hamiltonian, which has dimension 2^{2n_k} (not 2^{2n_k} since singly occupied pairs are excluded), corresponding to 2^{n_k} coupled linear algebraic equations.

So far, so good. But what does the solution tell us? Fourier transformation onto Wannier modes localized at lattice sites reads as

$$c_{\mathbf{r}\sigma} = \frac{1}{\sqrt{N}} \sum_{\mathbf{k}} e^{i\mathbf{k}\cdot\mathbf{r}} c_{\mathbf{k}\sigma}, \quad (10.81)$$

$$c_{\mathbf{k}\sigma} = \frac{1}{\sqrt{N}} \sum_{\mathbf{r}} e^{-i\mathbf{k}\cdot\mathbf{r}} c_{\mathbf{r}\sigma}. \quad (10.82)$$

First ignoring the momentum cutoff, the interaction in momentum space is

$$V_{\text{int}} = -\frac{V_0}{N} \sum_{\mathbf{k}\mathbf{k}'} c_{\mathbf{k}\uparrow}^\dagger c_{-\mathbf{k},\downarrow}^\dagger c_{-\mathbf{k}',\downarrow} c_{\mathbf{k}'\uparrow}. \quad (10.83)$$

The interaction in real space is then

$$V_{\text{int}} = -\frac{V_0}{N^3} \sum_{\mathbf{r}_1\mathbf{r}_2\mathbf{r}'_1\mathbf{r}'_2} \underbrace{\sum_{\mathbf{k}} e^{i\mathbf{k}\cdot(\mathbf{r}_1-\mathbf{r}_2)}}_{= N\delta_{\mathbf{r}_1\mathbf{r}_2}} \underbrace{\sum_{\mathbf{k}'} e^{i\mathbf{k}'\cdot(\mathbf{r}'_2-\mathbf{r}'_1)}}_{= N\delta_{\mathbf{r}'_1\mathbf{r}'_2}} c_{\mathbf{r}_1\uparrow}^\dagger c_{\mathbf{r}_2\downarrow}^\dagger c_{\mathbf{r}'_2\downarrow} c_{\mathbf{r}'_1\uparrow}$$

$$= -\frac{V_0}{N} \sum_{\mathbf{r}\mathbf{r}'} c_{\mathbf{r}\uparrow}^\dagger c_{\mathbf{r}\downarrow}^\dagger c_{\mathbf{r}'\downarrow} c_{\mathbf{r}'\uparrow}. \quad (10.84)$$

This is very strange. The interaction term scatters a localized pair from \mathbf{r}' to \mathbf{r} and thus violates the local conservation of charge. It not even decreases with separation; V_{int} describes arbitrary-range pair hopping. After restoring the momentum cutoff, the \mathbf{k} and \mathbf{k}' sum are performed over the momentum shell surrounding the Fermi surface. This can be done explicitly but the result is clear: The Kronecker delta symbols are replaced by decaying function of $\mathbf{r}_1 - \mathbf{r}_2$ and $\mathbf{r}'_1 - \mathbf{r}'_2$. The characteristic decay length is the inverse of the smallest characteristic momentum, which is the thickness $2\omega_D/v_F$ of the momentum shell. Hence, V_{int} scatters a pair centered at \mathbf{r}' and delocalized on a scale of $v_F/2\omega_D$ into a pair centered at \mathbf{r} and similarly delocalized. Thus the cutoff does not affect the main unphysical feature of V_{int} , i.e., the arbitrary-range hopping.

Exactly solving an unphysical model likely leads to unphysical results. The conclusion is that one should *not* use the simplified BCS Hamiltonian together with the exact Richardson solution for extended systems. The model does make a lot of sense within BCS mean-field theory. The restriction of the interaction to V_{int} was mainly motivated by the well-founded assumption that only the zero-momentum averages $\langle c_{\mathbf{k}\uparrow}^\dagger c_{-\mathbf{k}\downarrow}^\dagger \rangle$ become nonzero at the mean-field transition. The choice of V_{int} is in this sense part of the mean-field approximation. It should be added that the exact Richardson solution is useful when the nonlocality of the hopping is not crucial. This is the case for small systems such as nuclei and superconducting quantum dots.

10.4 Photoemission

The most direct probe of the quasiparticle dispersion in superconductors is angle-resolved photoemission spectroscopy (ARPES). Dropping the constant term from mean-field decoupling, the BCS Hamiltonian reads

$$\begin{aligned} H_{\text{BCS}} &= \sum_{\mathbf{k}\sigma} E_{\mathbf{k}} \gamma_{\mathbf{k}\sigma}^\dagger \gamma_{\mathbf{k}\sigma} - \sum_{\mathbf{k}} E_{\mathbf{k}} \\ &= \frac{1}{2} \sum_{\mathbf{k}\sigma} E_{\mathbf{k}} \gamma_{\mathbf{k}\sigma}^\dagger \gamma_{\mathbf{k}\sigma} + \frac{1}{2} \sum_{\mathbf{k}\sigma} E_{\mathbf{k}} (1 - \gamma_{\mathbf{k}\sigma} \gamma_{\mathbf{k}\sigma}^\dagger) - \sum_{\mathbf{k}} E_{\mathbf{k}} \\ &= \frac{1}{2} \sum_{\mathbf{k}\sigma} (E_{\mathbf{k}} \gamma_{\mathbf{k}\sigma}^\dagger \gamma_{\mathbf{k}\sigma} - E_{\mathbf{k}} \gamma_{\mathbf{k}\sigma} \gamma_{\mathbf{k}\sigma}^\dagger), \end{aligned} \quad (10.85)$$

with $E_{\mathbf{k}} = \sqrt{\xi_{\mathbf{k}}^2 + |\Delta|^2}$ or, generalized for a momentum-dependent gap parameter, $E_{\mathbf{k}} = \sqrt{\xi_{\mathbf{k}}^2 + |\Delta_{\mathbf{k}}|^2}$. The final form of H_{BCS} exhibits the symmetry of the dispersion relative to zero energy (i.e., the Fermi energy). $\gamma_{\mathbf{k}\sigma}^\dagger$ can be understood as creating a quasiparticle with positive energy $E_{\mathbf{k}}$ and $\gamma_{\mathbf{k}\sigma}$ can be understood as *creating* a quasiparticle with negative energy $-E_{\mathbf{k}}$. This interpretation double counts the degrees of freedom—there now appear to be four instead of two per momentum \mathbf{k} —which is cured by the prefactor $1/2$.

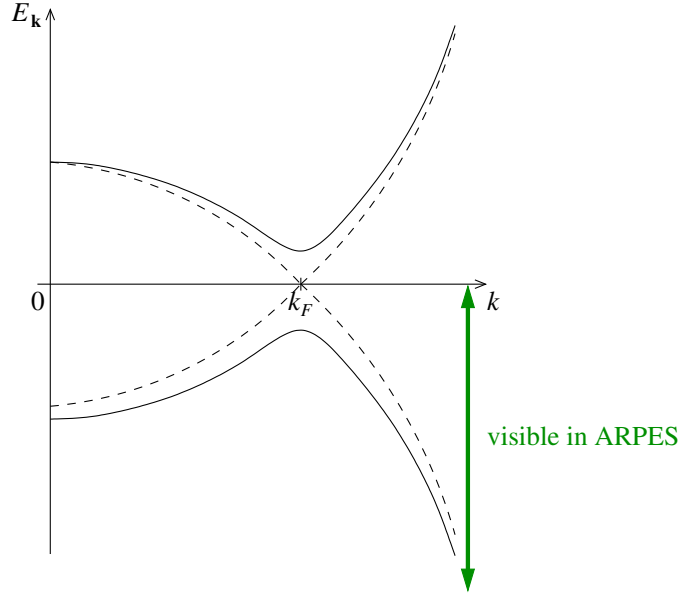

In this form, the quasiparticle states with negative energies are occupied in the ground state and it is thus impossible to create an additional quasiparticle here because of the Pauli principle. This is consistent with our new interpretation: these states would be created by $\gamma_{k\sigma}$, which also annihilates quasiparticles with positive energies, which do not exist in the ground state, hence the process is impossible. At nonzero temperatures, the occupation is described by the Fermi function so that some negative-energy states are empty and some positive-energy states are occupied.

In photoemission experiments, light of known frequency is directed at the sample and excites the quasiparticles. If the frequency and thus the photon energy is sufficiently high, the quasiparticle can be lifted up to the vacuum energy. Now a Bogoliubov quasiparticle cannot leave the superconductor since such an electron-hole superposition does not exist in vacuum. However, it does contain a nonzero electron component, which can leave the solid. This process requires that the photon energy is large enough to lift a quasiparticle from an occupied state, i.e., essentially from below the Fermi energy, to the vacuum energy. Photoemission experiments can thus map out the density of states of occupied states, up to matrix elements describing the coupling of the quasiparticles to the light and the probability of high-energy electrons leaving the solid.

ARPES in addition records the momentum of the emitted electron. This allows to reconstruct the momentum of the quasiparticle before photon absorption, which is very similar since photons of relevant energies have relatively small momenta. The upshot is that the whole dispersion of occupied states can, in principle, be mapped out. While ARPES is an extremely powerful method, it does not always work or does not work well, for a number of reasons:

- ARPES is difficult at low temperatures $T \lesssim 10$ K since the sample is heated by the light.
- ARPES requires good surface quality.
- ARPES is highly surface sensitive since the penetration length of light into a superconductor is very short. However, superconductors can have electronic states bound to the surface that might be difficult to disentangle from bulk contributions. In unconventional superconductors one is often interested specifically in the surface states, in which case ARPES is very useful if it works.

10.5 Isotope effect

How can one check that superconductivity is indeed governed by a phonon-mediated interaction? BCS theory predicts

$$k_B T_c, \Delta_0 \propto \omega_D \exp\left(-\frac{1}{V_0 D(E_F)}\right). \quad (10.86)$$

It would be ideal to compare $k_B T_c$ or Δ_0 for superconductors that only differ in the Debye frequency ω_D , not in V_0 of $D(E_F)$. This is at least approximately possible by using samples containing different isotopes (or different mixing ratios of isotopes) of the same elements.

The eigenfrequency of a harmonic oscillator scales with the mass like

$$\omega \sim \frac{1}{\sqrt{m}}. \quad (10.87)$$

The entire phonon dispersion, and thus in particular the Debye frequency, also scales like

$$\omega_{\mathbf{q}\lambda} \sim \frac{1}{\sqrt{M}}, \quad \omega_D \sim \frac{1}{\sqrt{M}} \quad (10.88)$$

with the atomic mass M for an elemental superconductor. The same scaling has been found above for the jellium model, see Eq. (8.73). Consequently, for elemental BCS weak-coupling superconductors,

$$k_B T_c, \Delta_0 \sim M^{-\alpha} \quad \text{with} \quad \alpha = \frac{1}{2}. \quad (10.89)$$

This is indeed found for simple superconductors. The exponent is found to be smaller or even negative for materials that are not in the weak-coupling regime $VD(E_F) \ll 1$ or that are not phonon-mediated superconductors. In particular, if the relevant interaction has nothing to do with phonons, we expect $\alpha = 0$. This is observed for optimally doped (highest T_c) cuprate high-temperature superconductors.

10.6 Specific heat

We now discuss further predictions following from BCS theory. We start by revisiting the heat capacity or specific heat. The BCS Hamiltonian

$$H_{\text{BCS}} = E_{\text{BCS}} + \sum_{\mathbf{k}\sigma} E_{\mathbf{k}} \gamma_{\mathbf{k}\sigma}^\dagger \gamma_{\mathbf{k}\sigma} \quad (10.90)$$

with

$$E_{\mathbf{k}} = \sqrt{\xi_{\mathbf{k}}^2 + |\Delta_{\mathbf{k}}|^2} \quad (10.91)$$

leads to the internal energy

$$U = \langle H_{\text{BCS}} \rangle = E_{\text{BCS}} + 2 \sum_{\mathbf{k}} E_{\mathbf{k}} n_F(E_{\mathbf{k}}). \quad (10.92)$$

However, this is inconvenient for the calculation of the heat capacity $C = dU/dT$ since the condensate energy E_{BCS} depends on temperature through $\langle c_{-\mathbf{k},\downarrow} c_{\mathbf{k}\uparrow} \rangle$. We better consider the entropy, which has no contribution from the condensate. It reads

$$S = -k_B \sum_{\mathbf{k}\sigma} [(1 - n_F) \ln(1 - n_F) + n_F \ln n_F], \quad (10.93)$$

where $n_F \equiv n_F(E_{\mathbf{k}})$. From the entropy, we obtain the heat capacity

$$\begin{aligned} C &= T \frac{dS}{dT} = -\beta \frac{dS}{d\beta} \\ &= 2k_B \beta \sum_{\mathbf{k}} \frac{d}{d\beta} [(1 - n_F) \ln(1 - n_F) + n_F \ln n_F] = 2k_B \beta \sum_{\mathbf{k}} \underbrace{[-\ln(1 - n_F) - 1 + \ln n_F + 1]}_{= \ln \frac{n_F}{1-n_F} = \ln e^{-\beta E_{\mathbf{k}}} = -\beta E_{\mathbf{k}}} \frac{dn_F}{d\beta} \\ &= -2k_B \beta^2 \sum_{\mathbf{k}} E_{\mathbf{k}} \frac{dn_F(E_{\mathbf{k}})}{d\beta}. \end{aligned} \quad (10.94)$$

Note that $n_F(E_{\mathbf{k}})$ depends on β or temperature both explicitly and through the temperature dependence of $E_{\mathbf{k}} = \sqrt{\xi_{\mathbf{k}}^2 + |\Delta_{\mathbf{k}}(T)|^2}$:

$$C = -2k_B\beta^2 \sum_{\mathbf{k}} E_{\mathbf{k}} \left(\underbrace{\frac{\partial n_F}{\partial \beta}}_{= \frac{E_{\mathbf{k}}}{\beta} \frac{\partial n_F}{\partial E_{\mathbf{k}}}} + \frac{\partial n_F}{\partial E_{\mathbf{k}}} \frac{1}{2E_{\mathbf{k}}} \frac{d|\Delta_{\mathbf{k}}|^2}{d\beta} \right) = -2k_B\beta \sum_{\mathbf{k}} \frac{\partial n_F}{\partial E_{\mathbf{k}}} \left(E_{\mathbf{k}}^2 + \frac{1}{2} \beta \frac{d|\Delta_{\mathbf{k}}|^2}{d\beta} \right). \quad (10.95)$$

The first term is due to the explicit β dependence, i.e., to the change of occupation of quasiparticle states with temperature. The second term results from the temperature dependence of the quasiparticle spectrum and is absent for $T \geq T_c$, where $|\Delta_{\mathbf{k}}|^2 = 0 = \text{const.}$ The sum over \mathbf{k} contains the factor

$$\frac{\partial n_F}{\partial E_{\mathbf{k}}} = \beta \frac{\partial}{\partial \beta} \frac{1}{e^{\beta E_{\mathbf{k}}} + 1} = -\beta \frac{e^{\beta E_{\mathbf{k}}}}{(e^{\beta E_{\mathbf{k}}} + 1)^2} = -\beta n_F(E_{\mathbf{k}})[1 - n_F(E_{\mathbf{k}})] \quad (10.96)$$

so that

$$C = 2k_B\beta^2 \sum_{\mathbf{k}} n_F(1 - n_F) \left(E_{\mathbf{k}}^2 + \frac{1}{2} \beta \frac{d|\Delta_{\mathbf{k}}|^2}{d\beta} \right). \quad (10.97)$$

Here, $n_F(1 - n_F)$ is exponentially small for $E_{\mathbf{k}} \gg k_B T$. This means that for $k_B T \ll \Delta_{\min}$, where Δ_{\min} is the minimum superconducting gap, *all* terms in the sum are exponentially suppressed since $k_B T \ll \Delta_{\min} \leq E_{\mathbf{k}}$. Thus the heat capacity is exponentially small at low temperatures. This result is not specific to superconductors—all systems with an energy gap for excitations show this behavior.

For the simple interaction used above, the heat capacity can be obtained in terms of an integral over energy. The numerical evaluation gives the following result:

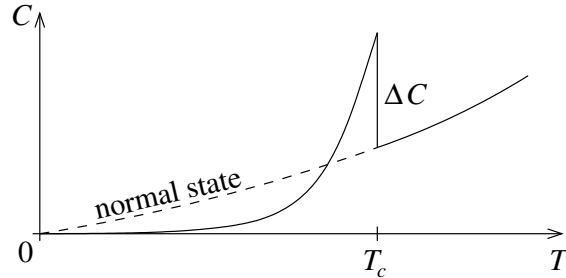

We find a downward jump at T_c , reproducing a result obtained from Landau theory in section 6.1. The jump occurs for any mean-field theory describing a second-order phase transition for a complex order parameter. Since BCS theory is such a theory, it recovers the result.

The height of the jump can be found as follows: The $E_{\mathbf{k}}^2$ term in Eq. (10.97) is continuous for $T \rightarrow T_c^-$ ($\Delta_0 \rightarrow 0$). Thus the jump height is given by

$$\Delta C = \frac{1}{k_B^2 T_c^3} \sum_{\mathbf{k}} n_F(\xi_{\mathbf{k}}) [1 - n_F(\xi_{\mathbf{k}})] \left. \frac{d\Delta_0^2}{d\beta} \right|_{T \rightarrow T_c^-}. \quad (10.98)$$

To obtain Δ_0 close to T_c , we have to solve the gap equation

$$1 = V_0 D(E_F) \int_{-\omega_D}^{\omega_D} d\xi \frac{\tanh \frac{\beta}{2} \sqrt{\xi^2 + \Delta_0^2}}{2\sqrt{\xi^2 + \Delta_0^2}} = V_0 D(E_F) \int_0^{\omega_D} d\xi \frac{\tanh \frac{\beta}{2} \sqrt{\xi^2 + \Delta_0^2}}{\sqrt{\xi^2 + \Delta_0^2}} \quad (10.99)$$

for small Δ_0 . Writing

$$\beta = \frac{1}{k_B T} = \frac{1}{k_B(T_c - \Delta T)} \quad (10.100)$$

and expanding for small ΔT and small Δ_0 , we obtain

$$\begin{aligned}
1 &\cong \underbrace{V_0 D(E_F) \int_0^{\omega_D} d\xi \frac{\tanh \frac{\xi}{2k_B T_c}}{\xi}}_{=1 \text{ (gap equation)}} + \frac{V_0 D(E_F)}{2k_B T_c^2} \Delta T \int_0^{\omega_D} \frac{d\xi}{\cosh^2 \frac{\xi}{2k_B T_c}} \\
&+ \frac{V_0 D(E_F)}{4k_B T_c} \Delta_0^2 \int_0^{\omega_D} \frac{d\xi}{\xi^2} \left(\frac{1}{\cosh^2 \frac{\xi}{2k_B T_c}} - \frac{2k_B T_c \tanh \frac{\xi}{2k_B T_c}}{\xi} \right). \tag{10.101}
\end{aligned}$$

In the weak-coupling limit, $\omega_D \gg k_B T_c$, we can extend the integrals to infinity, which yields

$$\begin{aligned}
0 &\cong \frac{V_0 D(E_F)}{2k_B T_c^2} \Delta T 2k_B T_c - \frac{V_0 D(E_F)}{4k_B T_c} \Delta_0^2 \frac{7\zeta(3)}{2k_B T_c} \\
&= V_0 D(E_F) \frac{\Delta T}{T_c} - V_0 D(E_F) \frac{7\zeta(3)}{8\pi^2} \frac{\Delta_0^2}{(k_B T_c)^2} \tag{10.102}
\end{aligned}$$

$$\Rightarrow \Delta_0^2 \cong \frac{8\pi^2}{7\zeta(3)} k_B^2 T_c \Delta T, \tag{10.103}$$

where $\zeta(z)$ is the Riemann zeta function. Thus

$$\begin{aligned}
\left. \frac{d\Delta_0^2}{d\beta} \right|_{T \rightarrow T_c^-} &= \frac{d\Delta T}{d\beta} \left. \frac{d\Delta_0^2}{d\Delta T} \right|_{\Delta T \rightarrow 0} = k_B T_c^2 \left. \frac{d\Delta_0^2}{d\Delta T} \right|_{\Delta T \rightarrow 0} \cong \frac{8\pi^2}{7\zeta(3)} k_B^3 T_c^3 \tag{10.104} \\
\Rightarrow \Delta C &= \frac{1}{k_B^2 T_c^3} \sum_{\mathbf{k}} n_F(\xi_{\mathbf{k}}) [1 - n_F(\xi_{\mathbf{k}})] \frac{8\pi^2}{7\zeta(3)} k_B^3 T_c^3 \\
&= \frac{8\pi^2}{7\zeta(3)} k_B N D(E_F) \underbrace{\int_{-\infty}^{\infty} d\xi n_F(\xi) [1 - n_F(\xi)]}_{=k_B T_c} \\
&= \frac{8\pi^2}{7\zeta(3)} N D(E_F) k_B^2 T_c, \tag{10.105}
\end{aligned}$$

where N is the number of unit cells. The specific-heat jump is

$$\Delta c = \frac{\Delta C}{V} = \frac{8\pi^2}{7\zeta(3)} d(E_F) k_B^2 T_c, \tag{10.106}$$

where $d(E_F) = D(E_F) N/V$ is the density of states per volume. Note that the ratio $\Delta c/d(E_F) k_B^2 T_c$ is another universal number within BCS theory.

10.7 Density of states and single-particle tunneling

Detailed experimental information on the excitation spectrum in a superconductor can be obtained from single-particle tunneling between a superconductor and either a normal metal or another superconductor. We discuss this in the following assuming, for simplicity, that the density of states $D(E)$ in the normal state is approximately constant close to the Fermi energy. We restrict ourselves to single-electron tunneling; pair tunneling, which leads to the Josephson effects, will be discussed later.

Quasiparticle density of states

The density of states per spin of the Bogoliubov quasiparticles created by γ^\dagger is easily obtained from their dispersion:

$$D_s(E) = \frac{1}{N} \sum_{\mathbf{k}} \delta(E - E_{\mathbf{k}}) = \frac{1}{N} \sum_{\mathbf{k}} \delta \left(E - \sqrt{\xi_{\mathbf{k}}^2 + |\Delta_{\mathbf{k}}|^2} \right). \tag{10.107}$$

The subscript “s” of $D_s(E)$ stands for “superconducting.” For the case of approximately constant normal-state density of states D_n and constant gap Δ_0 , we find

$$\begin{aligned}
D_s(E) &= \int_{-\infty}^{\infty} d\xi D_n(\mu - \xi) \delta\left(E - \sqrt{\xi^2 + \Delta_0^2}\right) \\
&\cong D_n(E_F) \int_{-\infty}^{\infty} d\xi \delta\left(E - \sqrt{\xi^2 + \Delta_0^2}\right) \\
&= D_n(E_F) 2 \int_0^{\infty} d\xi \delta\left(E - \sqrt{\xi^2 + \Delta_0^2}\right). \tag{10.108}
\end{aligned}$$

For $0 \leq E < \Delta_0$, the equation $E - \sqrt{\xi^2 + \Delta_0^2} = 0$ does not have a real solution for ξ and the integral vanishes. On the other hand, in the case $E > \Delta_0$ we use a standard result for the δ distribution to write

$$\begin{aligned}
\dots &= D_n(E_F) 2 \int_0^{\infty} d\xi \frac{\delta\left(\xi - \sqrt{E^2 - \Delta_0^2}\right)}{\left|\frac{\partial}{\partial \xi}\left(E - \sqrt{\xi^2 + \Delta_0^2}\right)\right|} \quad \Big| \quad \text{note } \xi \geq 0 \\
&= D_n(E_F) 2 \int_0^{\infty} d\xi \frac{\delta\left(\xi - \sqrt{E^2 - \Delta_0^2}\right)}{\frac{\xi}{\sqrt{\xi^2 + \Delta_0^2}}} \\
&= D_n(E_F) 2 \frac{E}{\sqrt{E^2 - \Delta_0^2}} \tag{10.109}
\end{aligned}$$

so that

$$D_s(E) \cong \begin{cases} D_n(E_F) \frac{2E}{\sqrt{E^2 - \Delta_0^2}} & \text{for } E > \Delta_0, \\ 0 & \text{for } 0 \leq E < \Delta_0. \end{cases} \tag{10.110}$$

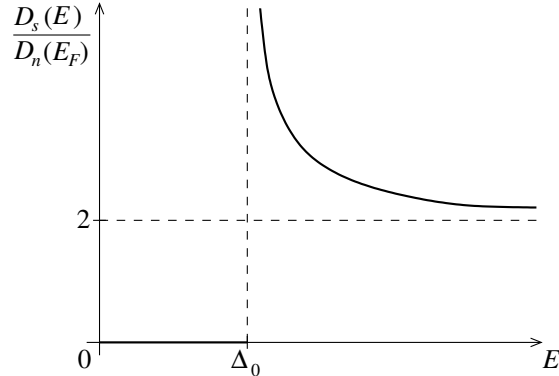

There are of course no states in the energy gap. Importantly, we find a *divergence* at the gap edge at $E = \Delta_0$. In the normal-state limit, $\Delta_0 \rightarrow 0$, we obtain $D_s(E)/D_n(E_F) \rightarrow 2$, deviating from the result of unity given in Tinkham’s book. The origin is that E is an excitation energy relative to the Fermi sea, i.e., both electron and hole excitations contribute to the density of states at positive E .

Single-particle tunneling

It is plausible that the density of states $D_s(E)$ can be mapped out by tunneling experiments, for example using a normal-metal/insulator/superconductor structure. However, we have to keep in mind that the particles tunneling

out of or into a normal metal are real electrons, whereas the quasiparticles in a superconductor are superpositions of electrons and holes. To study tunneling effects theoretically, we employ a *tunneling Hamiltonian* of the form

$$H = H_L + H_R + H_T, \quad (10.111)$$

where H_L and H_R describe the materials to the “left” and “right” of the tunneling region. Either can be a normal metal or a superconductor and is assumed to be unaffected by the presence of the tunneling region. For example, while translational invariance is necessarily broken in a tunneling device, we nevertheless write $H_{L,R}$ in terms of lattice-momentum states. H_T describes the tunneling between the two materials,

$$H_T = \sum_{\mathbf{k}\mathbf{q}\sigma} t_{\mathbf{k}\mathbf{q}} c_{\mathbf{k}\sigma}^\dagger d_{\mathbf{q}\sigma} + \text{h.c.} \quad (10.112)$$

Here, c and d are electronic operators referring to the two sides of the tunneling barrier and $t_{\mathbf{k}\mathbf{q}}$ is a tunneling matrix element, which might depend on the momenta of the incoming and outgoing electron. We assume a non-magnetic tunneling barrier so that the electron spin is conserved and $t_{\mathbf{k}\mathbf{q}}$ does not depend on it. We treat the two bulk materials in the mean-field approximation so that $H_{L,R}$ are effectively non-interacting mean-field Hamiltonians. We further assume constant normal-state densities of states and momentum-independent tunneling matrix elements $t = t_{\mathbf{k}\mathbf{q}}$.

For tunneling between *two normal metals*, we can calculate the current for an applied voltage V using the *Landauer formula*:

$$I_{nn} = \underbrace{I_{L \rightarrow R}}_{\text{left to right}} - \underbrace{I_{R \rightarrow L}}_{\text{right to left}}, \quad (10.113)$$

with

$$I_{L \rightarrow R} \propto \frac{2e}{h} \int_{-\infty}^{\infty} d\xi D_L^n(\mu + \xi) D_R^n(\mu + \xi + eV) |t|^2 n_F(\xi) [1 - n_F(\xi + eV)], \quad (10.114)$$

$$I_{R \rightarrow L} \propto \frac{2e}{h} \int_{-\infty}^{\infty} d\xi D_L^n(\mu + \xi) D_R^n(\mu + \xi + eV) |t|^2 n_F(\xi + eV) [1 - n_F(\xi)], \quad (10.115)$$

where $D_{L,R}^n$ is the density of states per spin direction in the left/right normal metal. The factors of n_F and $1 - n_F$ can be understood as the probabilities that the relevant initial states exist and are occupied and the final states exist and are empty. We get

$$\begin{aligned} I_{nn} &\propto \frac{2e}{h} \int_{-\infty}^{\infty} d\xi D_L^n(\mu + \xi) D_R^n(\mu + \xi + eV) |t|^2 [n_F(\xi) - n_F(\xi + eV)] \\ &\cong \frac{2e}{h} D_L^n(E_F) D_R^n(E_F) |t|^2 \int_{-\infty}^{\infty} d\xi [n_F(\xi) - n_F(\xi + eV)] \\ &= \frac{2e^2}{h} D_L^n(E_F) D_R^n(E_F) |t|^2 V. \end{aligned} \quad (10.116)$$

We thus find ohmic behaviour,

$$I_{nn} = G_{nn} V. \quad (10.117)$$

We next consider the case that one material is *normal* while the other (without loss of generality the left) is *superconducting*. Now there are additional factors because the quasiparticles in the superconductor are not pure electrons or holes. Let us say an electron is tunneling out of the superconductor with energy $\omega > 0$. First of all, this is only possible if $\omega \geq \Delta_0$ because of the energy gap. Now the electron can either come from an electron-like quasiparticle ($k > k_F$), which contains an electron portion of

$$|u_{\mathbf{k}}|^2 = \frac{1}{2} \left(1 + \frac{\xi_{\mathbf{k}}}{\sqrt{\xi_{\mathbf{k}}^2 + \Delta_0^2}} \right) \Big|_{\xi_{\mathbf{k}} = \sqrt{\omega^2 + \Delta_0^2}} = \frac{1}{2} \left(1 + \frac{\sqrt{\omega^2 - \Delta_0^2}}{\omega} \right), \quad (10.118)$$

or from a hole-like quasiparticle ($k' < k_F$) with an electron portion of

$$|u_{\mathbf{k}'}|^2 = \frac{1}{2} \left(1 + \frac{\xi_{\mathbf{k}'}}{\sqrt{\xi_{\mathbf{k}'}}^2 + \Delta_0^2} \right) \Big|_{\xi_{\mathbf{k}'} = -\sqrt{\omega^2 + \Delta_0^2}} = \frac{1}{2} \left(1 - \frac{\sqrt{\omega^2 - \Delta_0^2}}{\omega} \right). \quad (10.119)$$

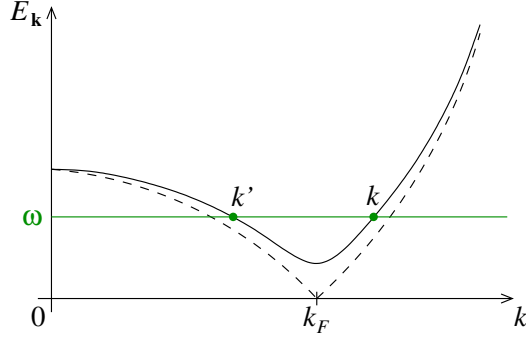

On the other hand, an electron tunneling out with energy $\omega < 0$ is best described as a hole tunneling in with energy $-\omega > 0$. The relevant factors are

$$|v_{\mathbf{k}}|^2 = \frac{1}{2} \left(1 - \frac{\sqrt{\omega^2 - \Delta_0^2}}{|\omega|} \right) \quad (10.120)$$

and

$$|v_{\mathbf{k}'}|^2 = \frac{1}{2} \left(1 + \frac{\sqrt{\omega^2 - \Delta_0^2}}{|\omega|} \right). \quad (10.121)$$

Thus the current flowing from left to right is

$$\begin{aligned} I_{L \rightarrow R} &\propto \frac{2e}{h} \int_0^{\infty} d\omega D_L^s(\omega) D_R^n(\mu + \omega + eV) |t|^2 n_F(\omega) [1 - n_F(\omega + eV)] \\ &\quad \times \underbrace{\left\{ \frac{1}{2} \left(1 + \frac{\sqrt{\omega^2 - \Delta_0^2}}{\omega} \right) + \frac{1}{2} \left(1 - \frac{\sqrt{\omega^2 - \Delta_0^2}}{\omega} \right) \right\}}_{=1} \\ &+ \frac{2e}{h} \int_{-\infty}^0 d\omega D_L^s(|\omega|) D_R^n(\mu + \omega + eV) |t|^2 n_F(\omega) [1 - n_F(\omega + eV)] \\ &\quad \times \underbrace{\left\{ \frac{1}{2} \left(1 - \frac{\sqrt{\omega^2 - \Delta_0^2}}{|\omega|} \right) + \frac{1}{2} \left(1 + \frac{\sqrt{\omega^2 - \Delta_0^2}}{|\omega|} \right) \right\}}_{=1} \\ &= \frac{2e}{h} \int_{-\infty}^{\infty} d\omega D_L^s(|\omega|) D_R^n(\mu + \omega + eV) |t|^2 n_F(\omega) [1 - n_F(\omega + eV)], \end{aligned} \quad (10.122)$$

where $D_L^s(\omega)$ now is the superconducting density of states, neither containing a spin factor of 2 nor the factor of 2 due describing both electrons and holes as excitations with positive energy—positive and negative energies are here treated explicitly and separately. We see that the electron-hole mixing does not lead to any additional factors beyond the changed density of states. With the analogous expression

$$I_{R \rightarrow L} \propto \frac{2e}{h} \int_{-\infty}^{\infty} d\omega D_L^s(|\omega|) D_R^n(\mu + \omega + eV) |t|^2 n_F(\omega + eV) [1 - n_F(\omega)] \quad (10.123)$$

we obtain

$$\begin{aligned}
I_{sn} &\propto \frac{2e}{h} \int_{-\infty}^{\infty} d\omega D_L^s(|\omega|) D_R^n(\mu + \omega + eV) |t|^2 [n_F(\omega) - n_F(\omega + eV)] \\
&\cong \frac{2e}{h} D_L^n(E_F) D_R^n(E_F) |t|^2 \int_{-\infty}^{\infty} d\omega \frac{D_L^s(|\omega|)}{D_L^n(E_F)} [n_F(\omega) - n_F(\omega + eV)],
\end{aligned} \tag{10.124}$$

where

$$\frac{D_L^s(|\omega|)}{D_L^n(E_F)} = \begin{cases} \frac{|\omega|}{\sqrt{\omega^2 - \Delta_0^2}} & \text{for } |\omega| > \Delta_0, \\ 0 & \text{for } |\omega| < \Delta_0. \end{cases} \tag{10.125}$$

Thus

$$I_{sn} = \frac{G_{nn}}{e} \int_{-\infty}^{\infty} d\omega \frac{D_L^s(|\omega|)}{D_L^n(E_F)} [n_F(\omega) - n_F(\omega + eV)]. \tag{10.126}$$

It is useful to consider the *differential conductance*

$$\begin{aligned}
G_{sn} &:= \frac{dI_{sn}}{dV} = G_{nn} \int_{-\infty}^{\infty} d\omega \frac{D_L^s(|\omega|)}{D_L^n(E_F)} \left(-\frac{\partial n_F(\omega + eV)}{\partial \omega} \right) \\
&= G_{nn} \int_{-\infty}^{\infty} d\omega \frac{D_L^s(|\omega|)}{D_L^n(E_F)} \beta n_F(\omega + eV) [1 - n_F(\omega + eV)].
\end{aligned} \tag{10.127}$$

In the limit $k_B T \rightarrow 0$ this becomes

$$G_{sn} = G_{nn} \int_{-\infty}^{\infty} d\omega \frac{D_L^s(|\omega|)}{D_L^n(E_F)} \delta(\omega + eV) = G_{nn} \frac{D_L^s(|eV|)}{D_L^n(E_F)}. \tag{10.128}$$

Thus low-temperature tunneling directly measures the superconducting density of states. At non-zero temperatures, the features are smeared out over an energy scale of $k_B T$. In the band picture we can see that the Fermi energy in the normal material is used to scan the density of states in the superconductor.

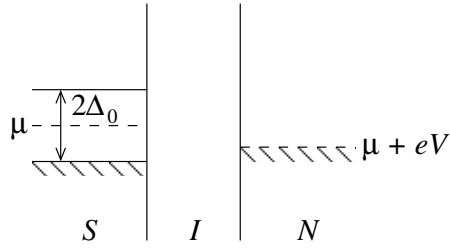

For a *superconductor-insulator-superconductor* contact, we only present the result for the current without derivation. The result is very plausible in view of the previous cases:

$$I_{ss} = \frac{G_{nn}}{e} \int_{-\infty}^{\infty} d\omega \frac{D_L^s(|\omega|)}{D_L^n(E_F)} \frac{D_R^s(|\omega + eV|)}{D_R^n(E_F)} [n_F(\omega) - n_F(\omega + eV)]. \tag{10.129}$$

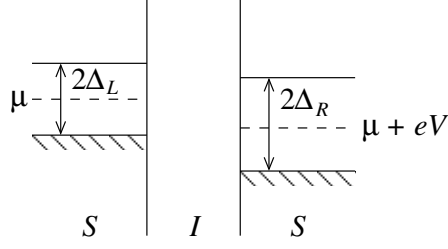

Now we find a large change in the current when the voltage V is chosen such that the lower gap edge at one side is aligned with the upper gap edge at the other side. This is the case for $|eV| = \Delta_L + \Delta_R$. This feature will remain sharp at non-zero temperatures since the densities of states retain their divergences at the gap edges as long as superconductivity is not destroyed. Effectively, we are using the density-of-states singularity of one superconductor to scan the density of states of the other. A numerical evaluation of I_{ss} gives the following typical behavior (here for $\Delta_L = 2k_B T$, $\Delta_R = 3k_B T$):

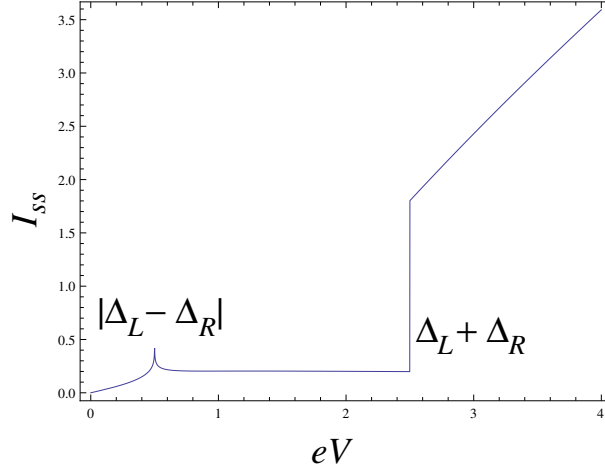

The roughly ohmic transport at small voltages is due to thermal activation over the gaps; note that $k_B T$ is not small compared to the gaps in this example. The peak at $eV = |\Delta_L - \Delta_R|$ is due to the coincidence of the singularities in the densities of states at the upper gap edge on both sides. The nearly constant current for $|\Delta_L - \Delta_R| < eV < \Delta_L + \Delta_R$ is, at first glance, surprising. More detailed analysis shows that both the contributions from tunneling below the gap and from tunneling above the gap approach constants as eV increases. What happens here is that the density-of-states peak at the upper gap edge on the left scans the states above the gap on the right, where both the density of states (far above the gap) and the occupation (essentially zero far above the chemical potential) are constant. Analogously, the density-of-states peak at the lower gap edge on the right scans the occupied states below the gap on the left. At $eV = \Delta_L + \Delta_R$, these two contributions are featureless. But now a new transport channel from *below* the gap on the left to *above* the gap on the right opens. Since the product of the densities of states diverges at the gap edges, the current increases with a jump. For higher applied voltage, additional states become available and the current increases continuously. In the limit $eV \gg \Delta_L, \Delta_R$, the superconducting gaps should be irrelevant and we expect and observe the ohmic behavior of a normal-normal contact.

10.8 Ultrasonic attenuation and nuclear relaxation

To conclude the brief survey of experimental consequences of BCS theory, we discuss the effects of time-dependent perturbations. They will be exemplified by ultrasonic attenuation and nuclear relaxation, which represent two distinct ways in which quasiparticle interference comes into play. Quite generally, we write the perturbation part of the Hamiltonian as

$$H_1 = \sum_{\mathbf{k}\mathbf{k}'} \sum_{\sigma\sigma'} B_{\mathbf{k}'\sigma'\mathbf{k}\sigma} c_{\mathbf{k}'\sigma'}^\dagger c_{\mathbf{k}\sigma}, \quad (10.130)$$

where $B_{\mathbf{k}'\sigma'\mathbf{k}\sigma}$ are matrix elements of the perturbation between single-electron states of the non-interacting system. In the superconducting state, we have to express c, c^\dagger in terms of γ, γ^\dagger ,

$$c_{\mathbf{k}\uparrow} = u_{\mathbf{k}}\gamma_{\mathbf{k}\uparrow} + v_{\mathbf{k}}\gamma_{-\mathbf{k},\downarrow}^\dagger, \quad (10.131)$$

$$c_{\mathbf{k}\downarrow} = u_{\mathbf{k}}\gamma_{\mathbf{k}\downarrow} - v_{\mathbf{k}}\gamma_{-\mathbf{k},\uparrow}^\dagger, \quad (10.132)$$

where we have assumed $u_{-\mathbf{k}} = u_{\mathbf{k}}, v_{-\mathbf{k}} = v_{\mathbf{k}}$. Thus, with $\sigma, \sigma' = \pm 1$,

$$\begin{aligned} H_1 &= \sum_{\mathbf{k}\mathbf{k}'} \sum_{\sigma\sigma'} B_{\mathbf{k}'\sigma'\mathbf{k}\sigma} \left(u_{\mathbf{k}'}^* \gamma_{\mathbf{k}'\sigma'}^\dagger + \sigma' v_{\mathbf{k}'}^* \gamma_{-\mathbf{k}',-\sigma'} \right) \left(u_{\mathbf{k}} \gamma_{\mathbf{k}\sigma} + \sigma v_{\mathbf{k}} \gamma_{-\mathbf{k},-\sigma}^\dagger \right) \\ &= \sum_{\mathbf{k}\mathbf{k}'} \sum_{\sigma\sigma'} B_{\mathbf{k}'\sigma'\mathbf{k}\sigma} \left(u_{\mathbf{k}'}^* u_{\mathbf{k}} \gamma_{\mathbf{k}'\sigma'}^\dagger \gamma_{\mathbf{k}\sigma} + \sigma u_{\mathbf{k}'}^* v_{\mathbf{k}} \gamma_{\mathbf{k}'\sigma'}^\dagger \gamma_{-\mathbf{k},-\sigma}^\dagger \right. \\ &\quad \left. + \sigma' v_{\mathbf{k}'}^* u_{\mathbf{k}} \gamma_{-\mathbf{k}',-\sigma'} \gamma_{\mathbf{k}\sigma} + \sigma \sigma' v_{\mathbf{k}'}^* v_{\mathbf{k}} \gamma_{-\mathbf{k}',-\sigma'} \gamma_{-\mathbf{k},-\sigma}^\dagger \right). \end{aligned} \quad (10.133)$$

It is useful to combine the terms containing $B_{\mathbf{k}'\sigma'\mathbf{k}\sigma}$ and $B_{-\mathbf{k},-\sigma,-\mathbf{k}',-\sigma'}$ since both refer to processes that change momentum by $\mathbf{k}' - \mathbf{k}$ and spin by $\sigma' - \sigma$. If the perturbation couples to the electron concentration, which is the case for ultrasound, one finds simply

$$B_{-\mathbf{k},-\sigma,-\mathbf{k}',-\sigma'} = B_{\mathbf{k}'\sigma'\mathbf{k}\sigma}. \quad (10.134)$$

This is often called *case I*. Furthermore, spin is conserved by the coupling to ultrasound, thus

$$B_{\mathbf{k}'\sigma'\mathbf{k}\sigma} = \delta_{\sigma\sigma'} B_{\mathbf{k}'\sigma\mathbf{k}\sigma}. \quad (10.135)$$

Adding the two terms, we obtain

$$\begin{aligned} H_{\text{ultra}} &= \frac{1}{2} \sum_{\mathbf{k}\mathbf{k}'} \sum_{\sigma} B_{\mathbf{k}'\sigma\mathbf{k}\sigma} \left(u_{\mathbf{k}'}^* u_{\mathbf{k}} \gamma_{\mathbf{k}'\sigma}^\dagger \gamma_{\mathbf{k}\sigma} + \sigma u_{\mathbf{k}'}^* v_{\mathbf{k}} \gamma_{\mathbf{k}'\sigma}^\dagger \gamma_{-\mathbf{k},-\sigma}^\dagger \right. \\ &\quad \left. + \sigma v_{\mathbf{k}'}^* u_{\mathbf{k}} \gamma_{-\mathbf{k}',-\sigma} \gamma_{\mathbf{k}\sigma} + v_{\mathbf{k}'}^* v_{\mathbf{k}} \gamma_{-\mathbf{k}',-\sigma} \gamma_{-\mathbf{k},-\sigma}^\dagger + u_{\mathbf{k}}^* u_{\mathbf{k}'} \gamma_{-\mathbf{k},-\sigma}^\dagger \gamma_{-\mathbf{k}',-\sigma} \right. \\ &\quad \left. - \sigma u_{\mathbf{k}}^* v_{\mathbf{k}'} \gamma_{-\mathbf{k},-\sigma}^\dagger \gamma_{\mathbf{k}'\sigma}^\dagger - \sigma v_{\mathbf{k}}^* u_{\mathbf{k}'} \gamma_{\mathbf{k}\sigma} \gamma_{-\mathbf{k}',-\sigma} + v_{\mathbf{k}}^* v_{\mathbf{k}'} \gamma_{\mathbf{k}\sigma} \gamma_{\mathbf{k}'\sigma}^\dagger \right). \end{aligned} \quad (10.136)$$

Assuming $u_{\mathbf{k}}, v_{\mathbf{k}}, \Delta_{\mathbf{k}} \in \mathbb{R}$ for simplicity, we get, up to a constant,

$$\begin{aligned} H_{\text{ultra}} &= \frac{1}{2} \sum_{\mathbf{k}\mathbf{k}'} \sum_{\sigma} B_{\mathbf{k}'\sigma\mathbf{k}\sigma} \left[(u_{\mathbf{k}'} u_{\mathbf{k}} - v_{\mathbf{k}'} v_{\mathbf{k}}) \left(\gamma_{\mathbf{k}'\sigma}^\dagger \gamma_{\mathbf{k}\sigma} + \gamma_{-\mathbf{k},-\sigma}^\dagger \gamma_{-\mathbf{k}',-\sigma} \right) \right. \\ &\quad \left. + \sigma (u_{\mathbf{k}'} v_{\mathbf{k}} + v_{\mathbf{k}'} u_{\mathbf{k}}) \left(\gamma_{\mathbf{k}'\sigma}^\dagger \gamma_{-\mathbf{k},-\sigma}^\dagger + \gamma_{-\mathbf{k}',-\sigma} \gamma_{\mathbf{k}\sigma} \right) \right]. \end{aligned} \quad (10.137)$$

We thus find effective matrix elements $B_{\mathbf{k}'\sigma\mathbf{k}\sigma}(u_{\mathbf{k}'} u_{\mathbf{k}} - v_{\mathbf{k}'} v_{\mathbf{k}})$ for quasiparticle scattering and $B_{\mathbf{k}'\sigma\mathbf{k}\sigma} \sigma (u_{\mathbf{k}'} v_{\mathbf{k}} + v_{\mathbf{k}'} u_{\mathbf{k}})$ for creation and annihilation of two quasiparticles. Transition rates calculated from Fermi's golden rule contain the absolute values squared of matrix elements. Thus the following two *coherence factors* will be important. The first one is

$$\begin{aligned} (u_{\mathbf{k}'} u_{\mathbf{k}} - v_{\mathbf{k}'} v_{\mathbf{k}})^2 &= \frac{1}{4} \left\{ \left(1 + \frac{\xi_{\mathbf{k}'}}{\sqrt{\xi_{\mathbf{k}'}}^2 + \Delta_{\mathbf{k}'}}^2} \right) \left(1 + \frac{\xi_{\mathbf{k}}}{\sqrt{\xi_{\mathbf{k}}}}^2 + \Delta_{\mathbf{k}}^2} \right) \right. \\ &\quad \left. - 2 \frac{\xi_{\mathbf{k}'}}{\sqrt{\xi_{\mathbf{k}'}}^2 + \Delta_{\mathbf{k}'}}^2} \frac{\xi_{\mathbf{k}}}{\sqrt{\xi_{\mathbf{k}}}}^2 + \Delta_{\mathbf{k}}^2} + \left(1 - \frac{\xi_{\mathbf{k}'}}{\sqrt{\xi_{\mathbf{k}'}}^2 + \Delta_{\mathbf{k}'}}^2} \right) \left(1 - \frac{\xi_{\mathbf{k}}}{\sqrt{\xi_{\mathbf{k}}}}^2 + \Delta_{\mathbf{k}}^2} \right) \right\} \\ &= \frac{1}{2} \left(1 + \frac{\xi_{\mathbf{k}} \xi_{\mathbf{k}'}}{E_{\mathbf{k}} E_{\mathbf{k}'}} - \frac{\Delta_{\mathbf{k}} \Delta_{\mathbf{k}'}}{E_{\mathbf{k}} E_{\mathbf{k}'}} \right) \end{aligned} \quad (10.138)$$

with $E_{\mathbf{k}} = \sqrt{\xi_{\mathbf{k}}^2 + \Delta_{\mathbf{k}}^2}$. If the coefficient B and the normal-state density of states are even functions of the normal-state energy relative to the Fermi energy, $\xi_{\mathbf{k}}$, the second term, which is odd in $\xi_{\mathbf{k}}$ and $\xi_{\mathbf{k}'}$, will drop out under the sum $\sum_{\mathbf{k}\mathbf{k}'}$. Hence, this term is usually omitted, giving the coherence factor

$$F_-(\mathbf{k}, \mathbf{k}') := \frac{1}{2} \left(1 - \frac{\Delta_{\mathbf{k}} \Delta_{\mathbf{k}'}}{E_{\mathbf{k}} E_{\mathbf{k}'}} \right) \quad (10.139)$$

relevant for quasiparticle scattering in ultrasound experiments. Analogously, we obtain the second coherence factor

$$\underbrace{\sigma^2}_{=1} (u_{\mathbf{k}'} v_{\mathbf{k}} + v_{\mathbf{k}'} u_{\mathbf{k}})^2 = \left(1 + \frac{\Delta_{\mathbf{k}} \Delta_{\mathbf{k}'}}{E_{\mathbf{k}} E_{\mathbf{k}'}} \right) =: F_+(\mathbf{k}, \mathbf{k}') \quad (10.140)$$

for quasiparticle creation and annihilation.

We can gain insight into the temperature dependence of ultrasound attenuation by making the rather crude approximation that the matrix element B is independent of \mathbf{k}, \mathbf{k}' and thus of energy. Furthermore, typical ultrasound frequencies Ω satisfy $\hbar\Omega \ll \Delta_0$ and $\hbar\Omega \ll k_B T$. Then only scattering of quasiparticles by phonons but not their creation is important since the phonon energy is not sufficient for quasiparticle creation. The annihilation of thermally excited quasiparticles is also irrelevant since it only contributes to the equilibrium background of phonons and directly only affects high-energy phonons in any case.

The rate of ultrasound absorption (attenuation) can be written in a plausible form analogous to the current in the previous section:

$$\alpha_s \propto \int_{-\infty}^{\infty} d\omega D_s(|\omega|) D_s(|\omega + \Omega|) |B|^2 F_-(\omega, \omega + \Omega) [n_F(\omega) - n_F(\omega + \Omega)], \quad (10.141)$$

where now

$$F_-(\omega, \omega') = \frac{1}{2} \left(1 - \frac{\Delta_0^2}{|\omega| |\omega'|} \right). \quad (10.142)$$

With the approximations introduced above we get

$$\alpha_s \propto D_n^2(E_F) |B|^2 \int_{-\infty}^{\infty} d\omega \frac{D_s(|\omega|)}{D_n(E_F)} \frac{D_s(|\omega + \Omega|)}{D_n(E_F)} \frac{1}{2} \left(1 - \frac{\Delta_0^2}{|\omega| |\omega + \Omega|} \right) [n_F(\omega) - n_F(\omega + \Omega)]. \quad (10.143)$$

The normal-state attenuation rate is found by letting $\Delta_0 \rightarrow 0$:

$$\alpha_n \propto D_n^2(E_F) |B|^2 \int_{-\infty}^{\infty} d\omega \frac{n_F(\omega) - n_F(\omega + \Omega)}{2} = \frac{1}{2} D_n^2(E_F) |B|^2 \Omega \quad (10.144)$$

$$\Rightarrow \frac{\alpha_s}{\alpha_n} = \frac{1}{\Omega} \int_{-\infty}^{\infty} d\omega \frac{D_s(|\omega|)}{D_n(E_F)} \frac{D_s(|\omega + \Omega|)}{D_n(E_F)} \frac{|\omega| |\omega + \Omega| - \Delta_0^2}{|\omega| |\omega + \Omega|} [n_F(\omega) - n_F(\omega + \Omega)]. \quad (10.145)$$

Since Ω is small, we can expand the integral up to linear order in Ω , noting that the term containing the Fermi functions is of at least first order,

$$\begin{aligned} \frac{\alpha_s}{\alpha_n} &\cong \frac{1}{\Omega} \int_{-\infty}^{\infty} d\omega \left[\frac{D_s(|\omega|)}{D_n(E_F)} \right]^2 \frac{\omega^2 - \Delta_0^2}{\omega^2} (-\Omega) \frac{\partial n_F}{\partial \omega} \\ &= - \left(\int_{-\infty}^{-\Delta_0} + \int_{\Delta_0}^{\infty} \right) d\omega \left[\frac{\omega}{\sqrt{\omega^2 - \Delta_0^2}} \right]^2 \frac{\omega^2 - \Delta_0^2}{\omega^2} \frac{\partial n_F}{\partial \omega} \\ &= - \left(\int_{-\infty}^{-\Delta_0} + \int_{\Delta_0}^{\infty} \right) d\omega \frac{\partial n_F}{\partial \omega} \\ &= \underbrace{-n_F(\infty)}_{=0} + n_F(\Delta_0) - n_F(-\Delta_0) + \underbrace{n_F(-\infty)}_{=1} \\ &= n_F(\Delta_0) + 1 - n_F(-\Delta_0) \end{aligned}$$

$$= 2 n_F(\Delta_0) = \frac{2}{e^{\beta\Delta_0} + 1}. \quad (10.146)$$

Inserting the BCS prediction for $\Delta_0(T)$, we can plot α_s/α_n vs. temperature:

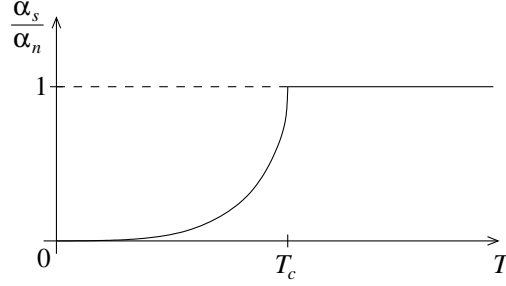

The suppression of the attenuation below T_c is clearly due to the opening of the superconducting gap—at low temperatures, there are exponentially few thermally excited quasiparticles that can scatter phonons. However, the simplicity of the result is deceptive. The density of states at the gap edge, where most of the quasiparticles reside, is singular so that one might expect a strong enhancement of α_s/α_n . The enhancement is canceled by the coherence factor F_- , which is coming from the matrix elements of the perturbation.

We now turn to the relaxation of nuclear spins due to their coupling to the electrons. We note without derivation that the hyperfine interaction relevant for this process is odd in momentum if the electron spin is not changed but is even if the electron spin is flipped, i.e.,

$$B_{-\mathbf{k}, -\sigma, -\mathbf{k}', -\sigma'} = -\sigma\sigma' B_{\mathbf{k}'\sigma'\mathbf{k}\sigma} \quad (10.147)$$

(recall $\sigma\sigma' = \pm 1$). This is called *case II*. The perturbation Hamiltonian now reads

$$\begin{aligned} H_{\text{NMR}} = & \frac{1}{2} \sum_{\mathbf{k}\mathbf{k}'} \sum_{\sigma\sigma'} B_{\mathbf{k}'\sigma'\mathbf{k}\sigma} \left(u_{\mathbf{k}'}^* u_{\mathbf{k}} \gamma_{\mathbf{k}'\sigma'}^\dagger \gamma_{\mathbf{k}\sigma} + \sigma u_{\mathbf{k}'}^* v_{\mathbf{k}} \gamma_{\mathbf{k}'\sigma'}^\dagger \gamma_{-\mathbf{k}, -\sigma}^{\dagger} \right. \\ & + \sigma' v_{\mathbf{k}'}^* u_{\mathbf{k}} \gamma_{-\mathbf{k}', -\sigma'} \gamma_{\mathbf{k}\sigma} + \sigma\sigma' v_{\mathbf{k}'}^* v_{\mathbf{k}} \gamma_{-\mathbf{k}', -\sigma'} \gamma_{-\mathbf{k}, -\sigma}^{\dagger} - \sigma\sigma' u_{\mathbf{k}'}^* u_{\mathbf{k}} \gamma_{-\mathbf{k}, -\sigma}^{\dagger} \gamma_{-\mathbf{k}', -\sigma'} \\ & \left. + \sigma u_{\mathbf{k}}^* v_{\mathbf{k}'} \gamma_{-\mathbf{k}, -\sigma}^{\dagger} \gamma_{\mathbf{k}'\sigma'}^\dagger + \sigma' v_{\mathbf{k}}^* u_{\mathbf{k}'} \gamma_{\mathbf{k}\sigma} \gamma_{-\mathbf{k}', -\sigma'} - v_{\mathbf{k}}^* v_{\mathbf{k}'} \gamma_{\mathbf{k}\sigma} \gamma_{\mathbf{k}'\sigma'}^\dagger \right). \end{aligned} \quad (10.148)$$

Assuming $u_{\mathbf{k}}, v_{\mathbf{k}}, \Delta_{\mathbf{k}} \in \mathbb{R}$, we get, up to a constant,

$$\begin{aligned} H_{\text{NMR}} = & \frac{1}{2} \sum_{\mathbf{k}\mathbf{k}'} \sum_{\sigma\sigma'} B_{\mathbf{k}'\sigma'\mathbf{k}\sigma} \left[(u_{\mathbf{k}'} u_{\mathbf{k}} + v_{\mathbf{k}'} v_{\mathbf{k}}) \left(\gamma_{\mathbf{k}'\sigma'}^\dagger \gamma_{\mathbf{k}\sigma} - \sigma\sigma' \gamma_{-\mathbf{k}, -\sigma}^{\dagger} \gamma_{-\mathbf{k}', -\sigma'} \right) \right. \\ & \left. + \sigma (u_{\mathbf{k}'} v_{\mathbf{k}} - v_{\mathbf{k}'} u_{\mathbf{k}}) \left(\gamma_{\mathbf{k}'\sigma'}^\dagger \gamma_{-\mathbf{k}, -\sigma}^{\dagger} - \sigma\sigma' \gamma_{-\mathbf{k}', -\sigma'} \gamma_{\mathbf{k}\sigma} \right) \right]. \end{aligned} \quad (10.149)$$

Compared to ultrasonic attenuation (case I) there is thus a change of sign in both coherence factors. An analogous derivation now gives the *interchanged* coherence factors

$$F_+(\mathbf{k}, \mathbf{k}') = \frac{1}{2} \left(1 + \frac{\Delta_{\mathbf{k}} \Delta_{\mathbf{k}'}}{E_{\mathbf{k}} E_{\mathbf{k}'}} \right) \quad (10.150)$$

for quasiparticle scattering and

$$F_-(\mathbf{k}, \mathbf{k}') = \frac{1}{2} \left(1 - \frac{\Delta_{\mathbf{k}} \Delta_{\mathbf{k}'}}{E_{\mathbf{k}} E_{\mathbf{k}'}} \right) \quad (10.151)$$

for quasiparticle creation and annihilation. The relevant energy $\hbar\Omega$ is the Zeeman energy of a nuclear spin in the applied uniform magnetic field and is small compared to the gap Δ_0 . Thus we can again restrict ourselves to the small- Ω limit. The derivation is initially analogous to case I, but with F_- replaced by F_+ . The nuclear-spin relaxation rate is

$$\alpha_s \propto \int_{-\infty}^{\infty} d\omega D_s(|\omega|) D_s(|\omega + \Omega|) |B|^2 F_+(\omega, \omega + \Omega) [n_F(\omega) - n_F(\omega + \Omega)] \quad (10.152)$$

with

$$F_+(\omega, \omega') = \frac{1}{2} \left(1 + \frac{\Delta_0^2}{|\omega||\omega'|} \right). \quad (10.153)$$

Thus

$$\alpha_s \propto D_n^2(E_F) |B|^2 \int_{-\infty}^{\infty} d\omega \frac{D_s(|\omega|)}{D_n(E_F)} \frac{D_s(|\omega + \Omega|)}{D_n(E_F)} \frac{1}{2} \left(1 + \frac{\Delta_0^2}{|\omega||\omega + \Omega|} \right) [n_F(\omega) - n_F(\omega + \Omega)] \quad (10.154)$$

$$\Rightarrow \frac{\alpha_s}{\alpha_n} = \frac{1}{\Omega} \int_{-\infty}^{\infty} d\omega \frac{D_s(|\omega|)}{D_n(E_F)} \frac{D_s(|\omega + \Omega|)}{D_n(E_F)} \frac{|\omega||\omega + \Omega| + \Delta_0^2}{|\omega||\omega + \Omega|} [n_F(\omega) - n_F(\omega + \Omega)]. \quad (10.155)$$

Note that the only difference compared to the corresponding Eq. (10.145) for ultrasound attenuation is the sign of Δ_0^2 in the numerator. If we now expand the integral for small Ω as above, we encounter a problem:

$$\frac{\alpha_s}{\alpha_n} \cong \frac{1}{\Omega} 2 \int_{\Delta_0}^{\infty} d\omega \left[\frac{\omega}{\sqrt{\omega^2 - \Delta_0^2}} \right]^2 \frac{\omega^2 + \Delta_0^2}{\omega^2} (-\Omega) \frac{\partial n_F}{\partial \omega} = -2 \int_{\Delta_0}^{\infty} d\omega \frac{\omega^2 + \Delta_0^2}{\omega^2 - \Delta_0^2} \frac{\partial n_F}{\partial \omega}. \quad (10.156)$$

This integral diverges logarithmically at the lower limit. Keeping a non-zero but realistically small Ω removes the divergence. However, the calculated α_s/α_n is still too large compared to experiments. The origin of this problem is the strong singularity in the superconducting density of states. A \mathbf{k} -dependent gap $\Delta_{\mathbf{k}}$ removes the problem; in a realistic theory $\Delta_{\mathbf{k}}$ always has a \mathbf{k} dependence since it cannot have higher symmetry than the underlying normal dispersion $\xi_{\mathbf{k}}$. Introducing some broadening of the density of states by hand, we numerically find the following temperature dependence:

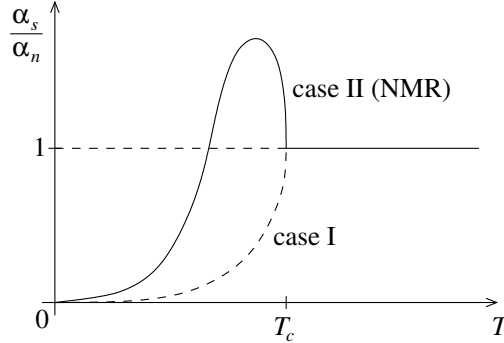

There is a large maximum below the transition temperature, called the *Hebel-Slichter peak*. It results from the factor $D_s^2(|\omega|)$ (for $\Omega \rightarrow 0$) in the integrand,

$$D_s^2(|\omega|) \cong D_n^2(E_F) \frac{\omega^2}{\omega^2 - \Delta_0^2}, \quad (10.157)$$

which for nuclear relaxation is not canceled by the coherence factor F_+ , whereas for ultrasonic attenuation it is canceled by F_- . Physically, the strong enhancement below T_c of the density of states of both initial and final states at $\omega \gtrsim \Delta_0$ leads to increased nuclear relaxation.

10.9 Ginzburg-Landau-Gor'kov theory

We conclude this chapter by remarking that Lev Gor'kov managed, two years after the publication of BCS theory, to derive Ginzburg-Landau theory from BCS theory. The correspondence is perfect if the gap is sufficiently small, i.e., T is close to T_c , and the electromagnetic field varies slowly on the scale of the Pippard coherence length ξ_0

(see Sec. 5.4). These are indeed the conditions under which Ginzburg and Landau expected their theory to be valid.

Gor'kov used equations of motion for electronic Green functions, which he decoupled with a mean-field-like approximation that allowed for spatial variations of the mean-field decoupling term $\Delta(\mathbf{r})$. The derivation is given in Schrieffer's book and we omit it here. A more modern exposition based on the function-integral method is given by Altland and Simons in *Condensed Matter Field Theory*. Gor'kov found that in order to obtain the Ginzburg-Landau equations, he had to take

$$q = -2e, \tag{10.158}$$

$$m^* = 2m, \tag{10.159}$$

as anticipated, and (using our conventions)

$$\psi(\mathbf{r}) = \frac{\sqrt{7\zeta(3)}}{4\pi} \sqrt{n_s^0} \frac{\Delta(\mathbf{r})}{k_B T_c}, \tag{10.160}$$

where

$$n_s^0 := \left. \frac{n_s}{1 - \frac{T}{T_c}} \right|_{T \rightarrow T_c^-}. \tag{10.161}$$

Recall that $n_s \sim 1 - T/T_c$ close to T_c in Ginzburg-Landau theory and thus $n_s^0 \approx \text{const}$. The spatially dependent gap is thus locally proportional to the Ginzburg-Landau “condensate wavefunction” or order parameter $\psi(\mathbf{r})$.

Since we have already found that London theory is a limiting case of Ginzburg-Landau theory, it is also a limiting case of BCS theory. But London theory predicts the two central properties of superconductors: Ideal conduction and flux expulsion. Thus Gor'kov's derivation also shows that BCS theory indeed describes a superconducting state. (Historically, this has been shown by BCS before Gor'kov established the formal relationship between the various theories.)

11

Josephson effects

Brian Josephson made two important predictions for the current flowing through a tunneling barrier between two superconductors. The results have later been extended to various other systems involving two superconducting electrodes, such as superconductor/normal-metal/superconductor heterostructures and superconducting weak links. We will first formulate his predictions and then derive them for the case of a weak link.

Rather generally, for *vanishing* applied voltage, a supercurrent I_s is flowing which is related to the phase difference $\Delta\phi$ of the two condensates by

$$I_s = I_c \sin \left(\Delta\phi - \frac{2\pi}{\Phi_0} \int d\mathbf{s} \cdot \mathbf{A} \right). \quad (11.1)$$

We will discuss the *critical current* I_c presently. Note that the form of the argument of the sine function is prescribed by gauge invariance. We consider the case without magnetic field so that we can choose the gauge $\mathbf{A} \equiv 0$. Then the Josephson relation simplifies to

$$I_s = I_c \sin \Delta\phi. \quad (11.2)$$

It describes the *DC Josephson effect*. The current continues to flow as long as the phase difference $\Delta\phi$ is maintained, although no bias voltage is applied.

Secondly, Josephson predicted that in the presence of a bias voltage V , the phase difference would evolve according to

$$\frac{d}{dt} \Delta\phi = -\frac{2e}{\hbar} V \quad (11.3)$$

(recall that we use the convention $e > 0$) so that for a constant voltage an alternating current would flow,

$$\Delta\phi(t) = \Delta\phi_0 - \frac{2e}{\hbar} Vt, \quad (11.4)$$

$$\Rightarrow I_s(t) = I_c \sin \left(\Delta\phi_0 - \frac{2e}{\hbar} Vt \right). \quad (11.5)$$

This is called the *AC Josephson effect*. The frequency

$$\omega_J := \frac{2eV}{\hbar} \quad (11.6)$$

of the current is called the *Josephson frequency*. The AC Josephson effect relates frequencies (or times) to voltages through the ratio $2e/\hbar$ of fundamental constants, which makes it important for metrology.

11.1 The Josephson effects in Ginzburg-Landau theory

We consider a weak link between two identical bulk superconductors. The weak link is realized by a short wire of length $L \ll \xi$ and cross section A made from the same material as the bulk superconductors. We choose this

setup since it is the easiest to treat in Ginzburg-Landau theory since the parameters α and β are uniform, but the only property that really matters is that the phase ϕ of the order parameter $\psi(\mathbf{r})$ only changes within the weak link.

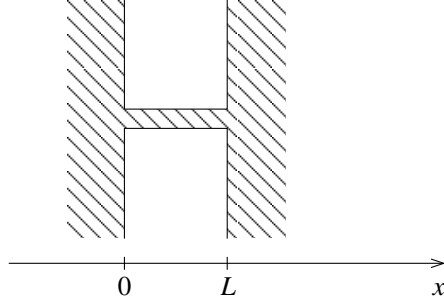

We employ the first Ginzburg-Landau equation for $\mathbf{A} \equiv 0$ assuming $\psi(\mathbf{r})$ to depend only on the coordinate x along the wire,

$$\xi^2 f''(x) + f(x) - |f(x)|^2 f(x) = 0 \quad (11.7)$$

with

$$f(x) = \frac{\psi(x)}{|\psi(\pm\infty)|} = \sqrt{-\frac{\beta}{\alpha}} \psi(x). \quad (11.8)$$

We assume the two bulk superconductors to be uniform and to have a relative phase of $\Delta\phi$. This allows us to write

$$f(x) = \begin{cases} 1 & \text{for } x \leq 0, \\ e^{i\Delta\phi} & \text{for } x \geq L. \end{cases} \quad (11.9)$$

For the wire we have to solve Eq. (11.7) with the boundary conditions

$$f(0) = 1, \quad f(L) = e^{i\Delta\phi}. \quad (11.10)$$

Since $L \ll \xi$, the first term in Eq. (11.7) is larger than the other two by a factor of order ξ^2/L^2 , unless $\Delta\phi = 0$, in which case the solution is trivially $f \equiv 1$. It is thus sufficient to solve $f''(x) = 0$, which has the solution¹

$$f(x) = \frac{L-x}{L} + \frac{x}{L} e^{i\Delta\phi}, \quad (11.11)$$

which linearly interpolates between $f(0)$ and $f(L)$. Inserting $f(x)$ into the second Ginzburg-Landau equation (with $\mathbf{A} \equiv 0$), we obtain

$$\begin{aligned} j_s &= i \frac{q\hbar}{2m^*} [(\psi')^* \psi - \psi^* \psi'] = -i \frac{e\hbar}{2m} \left(-\frac{\alpha}{\beta} \right) [(f')^* f - f^* f'] \\ &= -i \frac{e\hbar}{2m} 2n_s \left[\left(-\frac{1}{L} + \frac{1}{L} e^{-i\Delta\phi} \right) \left(\frac{L-x}{L} + \frac{x}{L} e^{i\Delta\phi} \right) - \left(\frac{L-x}{L} + \frac{x}{L} e^{-i\Delta\phi} \right) \left(-\frac{1}{L} + \frac{1}{L} e^{i\Delta\phi} \right) \right] \\ &= -i \frac{e\hbar n_s}{m} \left[-\frac{x}{L^2} (e^{i\Delta\phi} - e^{-i\Delta\phi}) - \frac{L-x}{L^2} (e^{i\Delta\phi} - e^{-i\Delta\phi}) \right] \\ &= 2 \frac{e\hbar n_s}{m} \left[-\frac{x}{L^2} \sin \Delta\phi - \frac{L-x}{L^2} \sin \Delta\phi \right] \\ &= -2 \frac{e\hbar n_s}{mL} \sin \Delta\phi. \end{aligned} \quad (11.12)$$

The current is obviously obtained by integrating over the cross-sectional area,

$$I_s = -\frac{2e\hbar n_s}{m} \frac{A}{L} \sin \Delta\phi \equiv I_c \sin \Delta\phi \quad (11.13)$$

¹Note that $f''(x) = 0$ implies a linear function $f(x)$, which is distinct from a linear dependence of the phase, $e^{i\Delta\phi x/L}$.

so that we get

$$I_c = -\frac{2e\hbar n_s}{m} \frac{A}{L}. \quad (11.14)$$

The negative sign is due to the negative charge $-2e$ of the Cooper pairs. The amplitude of the current-phase relation is clearly $|I_c|$. Note that the second Ginzburg-Landau equation is essentially the relation for the current density associated with a wave function in quantum mechanics. Thus the DC Josephson effect only relies on the presence of a macroscopic wave function of electrically charged entities, namely the Cooper pairs, or, in other words, on the presence of a charge condensate.

Ginzburg-Landau theory also gives us the free energy of the wire. Since we have neglected the α and β terms when solving the Ginzburg-Landau equation, we must for consistency do the same here,

$$\begin{aligned} F &= A \int_0^L dx \frac{\hbar^2}{4m} |\psi'(x)|^2 = A \int_0^L dx \frac{\hbar^2}{4m} \left(-\frac{\alpha}{\beta} \right) \left| -\frac{1}{L} + \frac{1}{L} e^{i\Delta\phi} \right|^2 = A \frac{\hbar^2}{4m} \frac{2n_s}{L^2} \int_0^L dx 2(1 - \cos \Delta\phi) \\ &= \frac{A}{L} \frac{\hbar^2 n_s}{m} (1 - \cos \Delta\phi). \end{aligned} \quad (11.15)$$

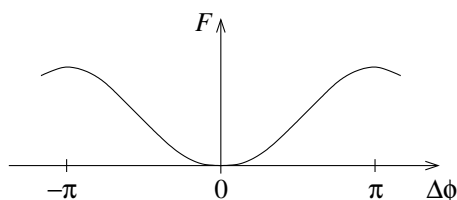

The free energy is minimal when the phases of the two superconductors coincide. Thus if there existed any mechanism by which the phases could relax, they would approach a state with uniform phase along the wire, a highly plausible result.

We can now also derive the AC Josephson effect. Assuming that the free energy of the junction is only changed by the supercurrent, we have

$$\frac{d}{dt} F = I_s V, \quad (11.16)$$

i.e., the electrical power. This relation implies that

$$\frac{\partial F}{\partial \Delta\phi} \frac{d}{dt} \Delta\phi = I_s V \quad (11.17)$$

$$\Rightarrow \frac{A}{L} \frac{\hbar^2 n_s}{m} \sin \Delta\phi \frac{d}{dt} \Delta\phi = -\frac{2e\hbar n_s}{m} \frac{A}{L} \sin \Delta\phi V \quad (11.18)$$

$$\Rightarrow \frac{d}{dt} \Delta\phi = -\frac{2e}{\hbar} V, \quad (11.19)$$

as stated above. Physically, if a supercurrent is flowing in the presence of a bias voltage, it generates power. Since energy is conserved, this power must equal the change of (free) energy per unit time of the junction.

11.2 Dynamics of Josephson junctions

For a discussion of the dynamical current-voltage characteristics of a Josephson junction, it is crucial to realize that a real junction also

1. permits single-particle tunneling (see Sec. 10.7), which we model by an ohmic resistance R in parallel to the junction,
2. has a non-zero capacitance C .

This leads to the *resistively and capacitively shunted junction (RCSJ) model* represented by the following circuit diagram:

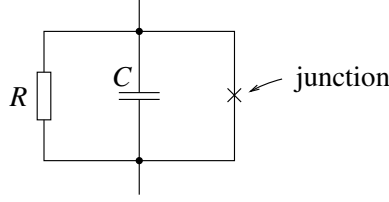

The current through the device is the sum of currents through the three branches,

$$I = \frac{V}{R} + C \frac{dV}{dt} - I_c \sin \Delta\phi, \quad (11.20)$$

where we take $I_c > 0$ and have made the sign explicit. With

$$\frac{d}{dt} \Delta\phi = -\frac{2e}{\hbar} V, \quad (11.21)$$

we obtain

$$I = -\frac{\hbar}{2eR} \frac{d}{dt} \Delta\phi - \frac{\hbar C}{2e} \frac{d^2}{dt^2} \Delta\phi - I_c \sin \Delta\phi. \quad (11.22)$$

We introduce the *plasma frequency*

$$\omega_p := \sqrt{\frac{2eI_c}{\hbar C}} \quad (11.23)$$

and the *quality factor*

$$Q := \omega_p R C \quad (11.24)$$

of the junction. This leads to

$$\frac{I}{I_c} = -\frac{1}{\omega_p^2} \frac{d^2}{dt^2} \Delta\phi - \frac{1}{Q\omega_p} \frac{d}{dt} \Delta\phi - \sin \Delta\phi \quad (11.25)$$

and with $\tau := \omega_p t$ finally to

$$\frac{d^2}{d\tau^2} \Delta\phi + \frac{1}{Q} \frac{d}{d\tau} \Delta\phi + \sin \Delta\phi = -\frac{I}{I_c}. \quad (11.26)$$

Compare this equation to the Newton equation for a particle moving in one dimension in a potential $V_{\text{pot}}(x)$ with friction (Stokes drag),

$$m\ddot{x} + \alpha\dot{x} = -\frac{dV_{\text{pot}}}{dx} \quad (11.27)$$

$$\Rightarrow \ddot{x} + \frac{\alpha}{m}\dot{x} = -\frac{1}{m} \frac{dV_{\text{pot}}}{dx}. \quad (11.28)$$

This Newton equation has the same form as the equation of motion of $\Delta\phi$ if we identify

$$t \leftrightarrow \tau, \quad (11.29)$$

$$x \leftrightarrow \Delta\phi, \quad (11.30)$$

$$\frac{\alpha}{m} \leftrightarrow \frac{1}{Q}, \quad (11.31)$$

$$\frac{1}{m} V_{\text{pot}}(x) \leftrightarrow \frac{I}{I_c} \Delta\phi - \cos \Delta\phi. \quad (11.32)$$

Thus the time dependence of $\Delta\phi(\tau)$ corresponds to the damped motion of a particle in a “tilted-washboard” potential

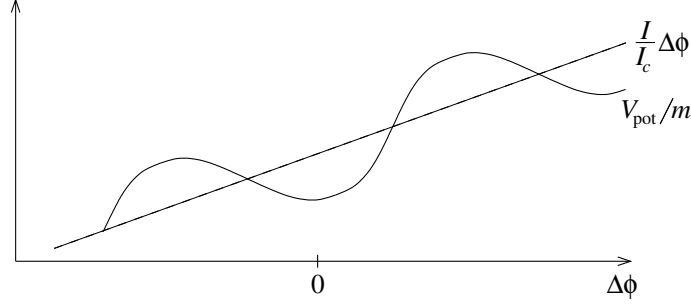

Equation (11.26) can be used to study a Josephson junction in various regimes. First, note that a stationary solution exists as long as the effective potential V_{pot} has local minima or at least points with vanishing derivative, which is the case for $|I| \leq I_c$. Then the stationary solution satisfies

$$\sin \Delta\phi = \text{const} = -\frac{I}{I_c} \quad \text{and} \quad V \equiv 0. \quad (11.33)$$

This solution does not exist for $|I| > I_c$. What happens if we impose a time-independent current that is larger than the critical current? We first consider a strongly damped junction, $Q \ll 1$. Then we can neglect the acceleration (inertial) term and write

$$\frac{1}{Q} \frac{d}{d\tau} \Delta\phi + \sin \Delta\phi = -\frac{I}{I_c} \quad (11.34)$$

$$\Rightarrow \frac{1}{Q} \frac{d}{d\tau} \Delta\phi = -\frac{I}{I_c} - \sin \Delta\phi \quad (11.35)$$

$$\Rightarrow -\frac{d\Delta\phi}{\frac{I}{I_c} + \sin \Delta\phi} = Q d\tau \quad (11.36)$$

$$\Rightarrow Q(\tau - \tau_0) = -\int_0^{\Delta\phi} \frac{d\Delta\phi'}{\frac{I}{I_c} + \sin \Delta\phi'} \stackrel{I \geq I_c}{=} -\frac{2}{\sqrt{\left(\frac{I}{I_c}\right)^2 - 1}} \arctan \frac{1 + \frac{I}{I_c} \tan \frac{\Delta\phi'}{2}}{\sqrt{\left(\frac{I}{I_c}\right)^2 - 1}} \Bigg|_0^{\Delta\phi}. \quad (11.37)$$

We are interested in periodic solutions for $e^{i\Delta\phi}$ or $\Delta\phi \bmod 2\pi$ since we expect the motion to approach a periodic function of time after a transient. One period T is the time it takes for $\Delta\phi$ to change from 0 to -2π (note that $d\Delta\phi/d\tau < 0$). For one period, we obtain

$$Q\omega_p T = -\int_0^{-2\pi} \frac{d\Delta\phi'}{\frac{I}{I_c} + \sin \Delta\phi'} \stackrel{I \geq I_c}{=} \frac{2\pi}{\sqrt{\left(\frac{I}{I_c}\right)^2 - 1}} \quad (11.38)$$

$$\Rightarrow T = \frac{2\pi}{Q\omega_p} \frac{1}{\sqrt{\left(\frac{I}{I_c}\right)^2 - 1}} = 2\pi \frac{\hbar}{2eI_c R} \frac{1}{\sqrt{\left(\frac{I}{I_c}\right)^2 - 1}} = \frac{\pi\hbar}{eR} \frac{1}{\sqrt{I^2 - I_c^2}}. \quad (11.39)$$

The voltage $V \propto -d\Delta\phi/dt$ is of course time-dependent but the *time-averaged voltage* is simply

$$\bar{V} = \frac{1}{T} \int_0^T dt V(t) = -\frac{\hbar}{2e} \frac{1}{T} \int_0^T dt \frac{d}{dt} \Delta\phi = -\frac{\hbar}{2e} \frac{1}{T} \underbrace{[\Delta\phi(T) - \Delta\phi(0)]}_{=-2\pi} = \frac{\pi\hbar}{e} \frac{1}{T} = R \sqrt{I^2 - I_c^2} \quad (11.40)$$

for $I > I_c$. By symmetry, $\bar{V} = -R \sqrt{I^2 - I_c^2}$ for $I < -I_c$. The current-voltage characteristics for imposed direct current (DC) I thus look like this:

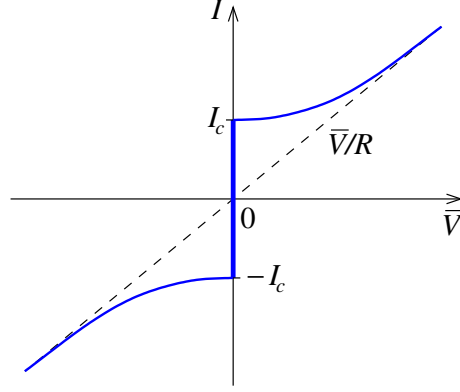

For $|I| \leq I_c$, the current flows without resistance. At I_c , non-zero DC and AC voltages set in gradually. For $|I| \gg I_c$, the DC voltage approaches the ohmic result for a normal contact.

The solution for general Q requires numerical calculation but we can analyze the opposite case of weak damping, $Q \gg 1$. The stationary solution $\Delta\phi = \text{const}$, $V = 0$ still exists for $I \leq I_c$. The mechanical analogy suggests that the time-dependent solution with periodic $e^{i\Delta\phi}$ will be a very rapid slide down the washboard, overlaid by a small-amplitude oscillation,

$$\Delta\phi \cong -\omega t + \delta\phi, \quad (11.41)$$

where $\omega \gg \omega_p$ and $\delta\phi$ is periodic in time and small. Inserting this ansatz into the equation of motion we find

$$\omega = Q \frac{I}{I_c} \omega_p \gg \omega_p, \quad (11.42)$$

$$\delta\phi \cong - \underbrace{\frac{\omega_p^2}{\omega^2}}_{\ll 1} \sin \omega t. \quad (11.43)$$

Thus

$$\Delta\phi \cong -\frac{\omega}{\omega_p} \tau - \frac{\omega_p^2}{\omega^2} \sin \frac{\omega}{\omega_p} \tau. \quad (11.44)$$

We convince ourselves that this is a good solution for $Q \gg 1$: Inserting it into Eq. (11.26), we obtain for the left-hand side

$$\begin{aligned} & \sin \frac{\omega}{\omega_p} \tau - \frac{1}{Q} \frac{\omega}{\omega_p} - \frac{1}{Q} \frac{\omega_p}{\omega} \cos \frac{\omega}{\omega_p} \tau - \sin \left(\frac{\omega}{\omega_p} \tau + \frac{\omega_p^2}{\omega^2} \sin \frac{\omega}{\omega_p} \tau \right) \\ & \cong \cancel{\sin \frac{\omega}{\omega_p} \tau} - \frac{I}{I_c} - \frac{1}{Q^2} \frac{I_c}{I} \cos \frac{\omega}{\omega_p} \tau - \cancel{\sin \frac{\omega}{\omega_p} \tau} - \left(\cos \frac{\omega}{\omega_p} \tau \right) \frac{1}{Q^2} \left(\frac{I_c}{I} \right)^2 \cos \frac{\omega}{\omega_p} \tau + \mathcal{O} \left(\frac{1}{Q^4} \right). \end{aligned} \quad (11.45)$$

To leading order in $1/Q$ this is just $-I/I_c$, which agrees with the right-hand side. We thus find an averaged voltage of

$$\bar{V} = \frac{1}{T} \int_0^T dt \left(-\frac{\hbar}{2e} \frac{d}{dt} \Delta\phi \right) = \frac{\hbar\omega}{2e} = \frac{\hbar}{2e} Q \frac{I}{I_c} \omega_p = \frac{\hbar}{2e} \frac{2eI_c}{\hbar C} RC \frac{I}{I_c} = RI, \quad (11.46)$$

i.e., the ohmic behavior of the normal junction. Note that the time-dependent solution exists for *all* currents, not just for $|I| > I_c$. Thus for $|I| \leq I_c$ there are now *two* solutions, with $V \equiv 0$ and with $\bar{V} = RI$. If we change the imposed current we expect hysteretic behavior. This is indeed observed.

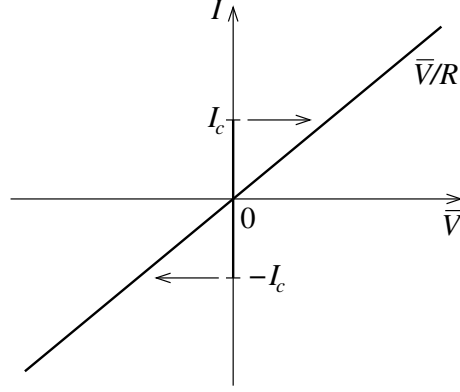

If we instead impose a constant voltage we obtain, for any Q ,

$$\frac{d}{dt} \Delta\phi = -\frac{2e}{\hbar} V = \text{const} \quad \Rightarrow \quad \frac{d^2}{dt^2} \Delta\phi = 0 \quad (11.47)$$

and thus

$$-\frac{1}{Q\omega_p} \frac{2e}{\hbar} V + \sin\left(-\frac{2e}{\hbar} Vt + \Delta\phi_0\right) = -\frac{I(t)}{I_c} \quad (11.48)$$

$$\Rightarrow I(t) = \frac{I_c}{Q\omega_p} \frac{2e}{\hbar} V + I_c \sin\left(\frac{2e}{\hbar} Vt - \Delta\phi_0\right). \quad (11.49)$$

The *averaged* current is just

$$\bar{I} = \frac{I_c}{Q\omega_p} \frac{2e}{\hbar} V = \frac{\hbar C}{2eI_c} \frac{I_c}{RC} \frac{2e}{\hbar} V = \frac{V}{R}, \quad (11.50)$$

i.e., it is ohmic. We emphasize that this result holds for any damping. It is evidently important to carefully specify whether a constant current or a constant voltage is imposed.

11.3 The Bogoliubov-de Gennes Hamiltonian

It is often necessary to describe inhomogeneous systems, Josephson junctions are typical examples. So far, the only theory we know that is able to treat inhomogeneity is the Ginzburg-Landau theory, which has the disadvantage that the quasiparticles are not explicitly included. It is in this sense not a microscopic theory. We will now discuss a microscopic description that allows us to treat inhomogeneous systems. The essential idea is to make the BCS mean-field Hamiltonian spatially dependent. This leads to the *Bogoliubov-de Gennes Hamiltonian*. It is useful to revert to a first-quantized description. To this end, we introduce the condensate state $|\psi_{\text{BCS}}\rangle$ as the ground state of the BCS Hamiltonian

$$H_{\text{BCS}} = \sum_{\mathbf{k}\sigma} \xi_{\mathbf{k}} c_{\mathbf{k}\sigma}^\dagger c_{\mathbf{k}\sigma} - \sum_{\mathbf{k}} \Delta_{\mathbf{k}}^* c_{-\mathbf{k},\downarrow} c_{\mathbf{k}\uparrow} - \sum_{\mathbf{k}} \Delta_{\mathbf{k}} c_{\mathbf{k}\uparrow}^\dagger c_{-\mathbf{k},\downarrow}^\dagger + \text{const}. \quad (11.51)$$

$|\psi_{\text{BCS}}\rangle$ agrees with the BCS ground state defined in Sec. 9.2 in the limit $T \rightarrow 0$ (recall that $\Delta_{\mathbf{k}}$ and thus H_{BCS} is temperature-dependent). We have

$$H_{\text{BCS}} |\psi_{\text{BCS}}\rangle = E_{\text{BCS}} |\psi_{\text{BCS}}\rangle, \quad (11.52)$$

where E_{BCS} is the temperature-dependent energy of the condensate.

Since H_{BCS} is bilinear, it is sufficient to consider single-particle excitations. Many-particle excitations are simply product states, or more precisely Slater determinants, of single-particle excitations. We first define a two-component spinor, also called *Nambu spinor*,

$$|\Psi_{\mathbf{k}}\rangle \equiv \begin{pmatrix} |\Psi_{\mathbf{k}1}\rangle \\ |\Psi_{\mathbf{k}2}\rangle \end{pmatrix} := \begin{pmatrix} c_{\mathbf{k}\uparrow}^\dagger |\psi_{\text{BCS}}\rangle \\ c_{-\mathbf{k},\downarrow} |\psi_{\text{BCS}}\rangle \end{pmatrix} = \begin{pmatrix} c_{\mathbf{k}\uparrow}^\dagger \\ c_{-\mathbf{k},\downarrow} \end{pmatrix} |\psi_{\text{BCS}}\rangle \quad (11.53)$$

describing the single-particle excitations. The $|\Psi_{\mathbf{k},1}\rangle$ and $|\Psi_{\mathbf{k},2}\rangle$ are not eigenstates of the BCS Hamiltonian, though. It is easy to show that

$$[H_{\text{BCS}}, c_{\mathbf{k}\uparrow}^\dagger] = \xi_{\mathbf{k}} c_{\mathbf{k}\uparrow}^\dagger - \Delta_{\mathbf{k}}^* c_{-\mathbf{k},\downarrow}, \quad (11.54)$$

$$[H_{\text{BCS}}, c_{-\mathbf{k},\downarrow}] = -\xi_{\mathbf{k}} c_{-\mathbf{k},\downarrow} - \Delta_{\mathbf{k}} c_{\mathbf{k}\uparrow}^\dagger. \quad (11.55)$$

With these relations we obtain

$$\begin{aligned} H_{\text{BCS}} |\Psi_{\mathbf{k}1}\rangle &= H_{\text{BCS}} c_{\mathbf{k}\uparrow}^\dagger |\psi_{\text{BCS}}\rangle = \left(\xi_{\mathbf{k}} c_{\mathbf{k}\uparrow}^\dagger - \Delta_{\mathbf{k}}^* c_{-\mathbf{k},\downarrow} + c_{\mathbf{k}\uparrow}^\dagger H_{\text{BCS}} \right) |\psi_{\text{BCS}}\rangle \\ &= (E_{\text{BCS}} + \xi_{\mathbf{k}}) |\Psi_{\mathbf{k}1}\rangle - \Delta_{\mathbf{k}}^* |\Psi_{\mathbf{k}2}\rangle \end{aligned} \quad (11.56)$$

and

$$\begin{aligned} H_{\text{BCS}} |\Psi_{\mathbf{k}2}\rangle &= H_{\text{BCS}} c_{-\mathbf{k},\downarrow} |\psi_{\text{BCS}}\rangle = \left(-\xi_{\mathbf{k}} c_{-\mathbf{k},\downarrow} - \Delta_{\mathbf{k}} c_{\mathbf{k}\uparrow}^\dagger + c_{-\mathbf{k},\downarrow} H_{\text{BCS}} \right) |\psi_{\text{BCS}}\rangle \\ &= (E_{\text{BCS}} - \xi_{\mathbf{k}}) |\Psi_{\mathbf{k}2}\rangle - \Delta_{\mathbf{k}} |\Psi_{\mathbf{k}1}\rangle. \end{aligned} \quad (11.57)$$

Thus for the basis $\{|\Psi_{\mathbf{k}1}\rangle, |\Psi_{\mathbf{k}2}\rangle\}$, the Hamiltonian has the matrix form

$$\begin{pmatrix} E_{\text{BCS}} + \xi_{\mathbf{k}} & -\Delta_{\mathbf{k}} \\ -\Delta_{\mathbf{k}}^* & E_{\text{BCS}} - \xi_{\mathbf{k}} \end{pmatrix}. \quad (11.58)$$

This is the desired Hamiltonian in first-quantized form, except that we want to measure excitation energies relative to the condensate energy. Thus we write as the first-quantized Hamiltonian in \mathbf{k} space

$$\mathcal{H}_{\text{BdG}}(\mathbf{k}) = \begin{pmatrix} \xi_{\mathbf{k}} & -\Delta_{\mathbf{k}} \\ -\Delta_{\mathbf{k}}^* & -\xi_{\mathbf{k}} \end{pmatrix}. \quad (11.59)$$

This is the Bogoliubov-de Gennes Hamiltonian for non-magnetic superconductors. The upper left (lower right) component describes spin-up electrons (spin-down holes). The electron-hole transformation performed for the spin-down particles allows one to implement superpositions of spin-up electrons and spin-down holes by nonzero off-diagonal components $-\Delta_{\mathbf{k}}$, $-\Delta_{\mathbf{k}}^*$.

The eigenvalues of the Bogoliubov-de Gennes Hamiltonian are

$$\pm \sqrt{\xi_{\mathbf{k}}^2 + |\Delta_{\mathbf{k}}|^2} = \pm E_{\mathbf{k}} \quad (11.60)$$

with corresponding eigenstates

$$u_{\mathbf{k}} |\Psi_{\mathbf{k}1}\rangle - v_{\mathbf{k}}^* |\Psi_{\mathbf{k}2}\rangle = \left(u_{\mathbf{k}} c_{\mathbf{k}\uparrow}^\dagger - v_{\mathbf{k}}^* c_{-\mathbf{k},\downarrow} \right) |\psi_{\text{BCS}}\rangle = \gamma_{\mathbf{k}\uparrow}^\dagger |\psi_{\text{BCS}}\rangle \quad (11.61)$$

and

$$v_{\mathbf{k}} |\Psi_{\mathbf{k}1}\rangle + u_{\mathbf{k}}^* |\Psi_{\mathbf{k}2}\rangle = \left(v_{\mathbf{k}} c_{\mathbf{k}\uparrow}^\dagger + u_{\mathbf{k}}^* c_{-\mathbf{k},\downarrow} \right) |\psi_{\text{BCS}}\rangle = \gamma_{-\mathbf{k},\downarrow} |\psi_{\text{BCS}}\rangle \quad (11.62)$$

with $u_{\mathbf{k}}, v_{\mathbf{k}}$ defined as above. (A lengthy but straightforward calculation has been omitted.) We can now understand why the second eigenvalue comes out negative: The corresponding eigenstate contains a quasiparticle *annihilation* operator, not a *creation* operator. The excitation energies are the positive energies that we already know.

The next step is to Fourier-transform the Hamiltonian to obtain its real-space representation, which we write as

$$\mathcal{H}_{\text{BdG}}(\mathbf{r}) := \frac{1}{N} \sum_{\mathbf{k}} e^{i\mathbf{k}\cdot\mathbf{r}} \mathcal{H}_{\text{BdG}}(\mathbf{k}) = \begin{pmatrix} H_0(\mathbf{r}) & -\Delta(\mathbf{r}) \\ -\Delta^*(\mathbf{r}) & -H_0(\mathbf{r}) \end{pmatrix}, \quad (11.63)$$

where

$$H_0(\mathbf{r}) = -\frac{\hbar^2}{2m} \nabla^2 - \mu + V(\mathbf{r}) \quad (11.64)$$

is the noninteracting-electron Hamiltonian. One often uses effective lattice models of the form of tight-binding models for both $H_0(\mathbf{r})$ and $\Delta(\mathbf{r})$. It is now easy to include spatially inhomogeneous situations: Both $V(\mathbf{r})$ and $\Delta(\mathbf{r})$ can be chosen spatially dependent. The relevant case is when they are not just lattice periodic. The corresponding Schrödinger equation

$$\mathcal{H}_{\text{BdG}}(\mathbf{r}) \Psi(\mathbf{r}) = E \Psi(\mathbf{r}) \quad (11.65)$$

with

$$\Psi(\mathbf{r}) = \begin{pmatrix} \Psi_1(\mathbf{r}) \\ \Psi_2(\mathbf{r}) \end{pmatrix} \quad (11.66)$$

is called the *Bogoliubov-de Gennes equation*. Note that in this context the gap $\Delta(\mathbf{r})$ is usually defined with the opposite sign, which is just a phase change, so that the explicit minus signs in the off-diagonal components of \mathcal{H}_{BdG} are removed. Furthermore, in Bogoliubov-de Gennes theory, the gap function is typically not evaluated selfconsistently from the averages $\langle c_{-\mathbf{k},\downarrow} c_{\mathbf{k}\uparrow} \rangle$. Rather, $\Delta(\mathbf{r})$ is treated as a given function characterizing the strength of superconducting pairing. It is often called the “pairing potential.” But if required it is certainly possible to evaluate $\Delta(\mathbf{r})$ selfconsistently by solving a BCS gap equation in real space.

11.4 Andreev reflection

As an application of the Bogoliubov-de Gennes approach, we study what happens to an electron that impinges on a normal-superconducting interface from the normal side. We model this situation by the Bogoliubov-de Gennes Hamiltonian

$$\mathcal{H}_{\text{BdG}} = \begin{pmatrix} -\frac{\hbar^2}{2m} \nabla^2 - \mu & \Delta_0 \Theta(x) \\ \Delta_0 \Theta(x) & \frac{\hbar^2}{2m} \nabla^2 + \mu \end{pmatrix} \quad (11.67)$$

(note the changed sign of $\Delta(\mathbf{r})$) appearing in

$$\mathcal{H}_{\text{BdG}} \Psi(\mathbf{r}) = E \Psi(\mathbf{r}). \quad (11.68)$$

In the normal region, $x < 0$, the component $\Psi_1(\mathbf{r})$ ($\Psi_2(\mathbf{r})$) is just a superposition of plane waves with wave vectors \mathbf{k}_1 (\mathbf{k}_2) which must satisfy

$$k_1^2 = 2m(\mu + E) = k_F^2 + 2mE, \quad (11.69)$$

$$k_2^2 = 2m(\mu - E) = k_F^2 - 2mE, \quad (11.70)$$

where $\hbar = 1$. In the superconductor, $x > 0$, we have

$$\left(-\frac{1}{2m} \nabla^2 - \mu \right) \Psi_1(\mathbf{r}) + \Delta_0 \Psi_2(\mathbf{r}) = E \Psi_1(\mathbf{r}), \quad (11.71)$$

$$\left(\frac{1}{2m} \nabla^2 + \mu \right) \Psi_2(\mathbf{r}) + \Delta_0 \Psi_1(\mathbf{r}) = E \Psi_2(\mathbf{r}) \quad (11.72)$$

$$\Rightarrow \Psi_2(\mathbf{r}) = \frac{E + \frac{1}{2m} \nabla^2 + \mu}{\Delta_0} \Psi_1(\mathbf{r}) \quad (11.73)$$

$$\Rightarrow \left(\frac{1}{2m} \nabla^2 + \mu \right)^2 \Psi_1(\mathbf{r}) = (E^2 - \Delta_0^2) \Psi_1(\mathbf{r}) \quad (11.74)$$

and analogously

$$\left(\frac{1}{2m} \nabla^2 + \mu \right)^2 \Psi_2(\mathbf{r}) = (E^2 - \Delta_0^2) \Psi_2(\mathbf{r}). \quad (11.75)$$

If the energy is above the gap, $|E| > \Delta_0$, the solutions are plane wave vectors $\mathbf{q}_1, \mathbf{q}_2$, where now

$$\left(\frac{q_{1,2}^2}{2m} - \mu \right)^2 = E^2 - \Delta_0^2 > 0 \quad (11.76)$$

$$\Rightarrow q_{1,2}^2 = 2m \left(\mu + \sqrt{E^2 - \Delta_0^2} \right), \quad (11.77)$$

and amplitudes coupled by Eq. (11.73).

We are here interested in the more surprising case $|E| < \Delta_0$. Since the solution must be continuous across the interface and is plane-wave-like in the normal region, we make the ansatz

$$\Psi_1(\mathbf{r}) = e^{i(k_{1y}y + k_{1z}z)} \Phi_1(x), \quad (11.78)$$

from which, for $x \geq 0$,

$$\left(-\frac{k_{1\parallel}^2}{2m} + \frac{1}{2m} \frac{d^2}{dx^2} + \mu \right)^2 \Phi_1(x) = (E^2 - \Delta_0^2) \Phi_1(x) \quad (11.79)$$

with $\mathbf{k}_{1\parallel} := (k_{1y}, k_{1z})$. Since this equation is linear with constant coefficients, we make an exponential ansatz

$$\Phi_1(x) = e^{\kappa x + iqx} \quad (11.80)$$

with $\kappa, q \in \mathbb{R}$. This leads to

$$\left(-\frac{k_{1\parallel}^2}{2m} + \frac{(\kappa + iq)^2}{2m} + \mu \right)^2 = \underbrace{E^2 - \Delta_0^2}_{< 0} \quad (11.81)$$

$$\begin{aligned} \Rightarrow \left(-\frac{k_{1\parallel}^2 + q^2}{2m} + \mu + \frac{i\kappa q}{m} + \frac{\kappa^2}{2m} \right)^2 &= \left(\frac{k_{1\parallel}^2 + q^2}{2m} - \mu - \frac{\kappa^2}{2m} - \frac{i\kappa q}{m} \right)^2 \\ &= \left(\frac{k_{1\parallel}^2 + q^2}{2m} - \mu - \frac{\kappa^2}{2m} \right)^2 - \frac{\kappa^2 q^2}{m^2} - 2 \frac{i\kappa q}{m} \left(\frac{k_{1\parallel}^2 + q^2}{2m} - \mu - \frac{\kappa^2}{2m} \right) = E^2 - \Delta_0^2. \end{aligned} \quad (11.82)$$

Since the right-hand side is real, we require

$$\frac{k_{1\parallel}^2 + q^2}{2m} - \mu - \frac{\kappa^2}{2m} = 0 \quad (11.83)$$

$$\Rightarrow \kappa^2 = k_{1\parallel}^2 + q^2 - 2m\mu = k_F^2 - k_{1\parallel}^2 + q^2. \quad (11.84)$$

For the real part it follows that

$$-\frac{\kappa^2 q^2}{m^2} = E^2 - \Delta_0^2 \quad (11.85)$$

$$\Rightarrow \frac{\kappa^2 q^2}{m^2} = \frac{(k_{1\parallel}^2 + q^2 - 2m\mu) q^2}{m^2} = \Delta_0^2 - E^2 > 0 \quad (11.86)$$

$$\Rightarrow q^4 + (k_{1\parallel}^2 - 2m\mu) q^2 - m^2(\Delta_0^2 - E^2) = 0 \quad (11.87)$$

$$\begin{aligned} \Rightarrow q^2 &= \frac{2m\mu - k_{1\parallel}^2}{2} \pm \sqrt{\left(\frac{2m\mu - k_{1\parallel}^2}{2} \right)^2 + m^2(\Delta_0^2 - E^2)} \\ &= \frac{1}{2} \left[k_F^2 - k_{1\parallel}^2 \pm \sqrt{(k_F^2 - k_{1\parallel}^2)^2 + 4m^2(\Delta_0^2 - E^2)} \right]. \end{aligned} \quad (11.88)$$

Both solutions are clearly real but the one with the minus sign is negative so that q would be imaginary, contrary to our assumption. Thus the relevant solutions are

$$q = \pm q_1 := \pm \frac{1}{\sqrt{2}} \sqrt{k_F^2 - k_{1\parallel}^2 + \sqrt{(k_F^2 - k_{1\parallel}^2)^2 + 4m^2(\Delta_0^2 - E^2)}}. \quad (11.89)$$

It also follows that

$$\begin{aligned}\kappa^2 &= k_{1\parallel}^2 - k_F^2 + \frac{1}{2} \left[k_F^2 - k_{1\parallel}^2 + \sqrt{(k_F^2 - k_{1\parallel}^2)^2 + 4m^2(\Delta_0^2 - E^2)} \right] \\ &= \frac{1}{2} \left[k_{1\parallel}^2 - k_F^2 + \sqrt{(k_F^2 - k_{1\parallel}^2)^2 + 4m^2(\Delta_0^2 - E^2)} \right]\end{aligned}\quad (11.90)$$

and

$$\kappa = -\kappa_1 := -\frac{1}{\sqrt{2}} \sqrt{k_{1\parallel}^2 - k_F^2 + \sqrt{(k_F^2 - k_{1\parallel}^2)^2 + 4m^2(\Delta_0^2 - E^2)}}. \quad (11.91)$$

The positive root exists but would lead to a solution that grows exponentially for $x \rightarrow \infty$. For $\Psi_2(\mathbf{r})$ the derivation is completely analogous. However, $\Psi_1(\mathbf{r})$ and $\Psi_2(\mathbf{r})$ are related by Eq. (11.73), which for exponential functions becomes a simple proportionality. Therefore, we must have $\mathbf{k}_{2\parallel} = \mathbf{k}_{1\parallel}$, which already implies $q_2 = q_1$ and $\kappa_2 = \kappa_1$. Then we have

$$\begin{aligned}\Psi_2(\mathbf{r}) &= \frac{E + \frac{1}{2m}\nabla^2 + \mu}{\Delta_0} \Psi_1(\mathbf{r}) = \frac{1}{\Delta_0} \left[E + \frac{(-\kappa_1 \pm iq_1)^2}{2m} - \frac{k_{1\parallel}^2}{2m} + \mu \right] \Psi_1(\mathbf{r}) \\ &= \frac{1}{\Delta_0} \left[E - \underbrace{\frac{k_{1\parallel}^2 + q^2}{2m}}_{=0} + \mu + \frac{\kappa_1^2}{2m} \mp i \frac{\kappa_1 q_1}{m} \right] \Psi_1(\mathbf{r}).\end{aligned}\quad (11.92)$$

Since we already know that

$$\frac{\kappa_1^2 q_1^2}{m^2} = \Delta_0^2 - E^2 \quad (11.93)$$

and κ_1, q_1 have been defined as positive, we get

$$\Psi_2(\mathbf{r}) = \frac{E \mp i\sqrt{\Delta_0^2 - E^2}}{\Delta_0} \Psi_1(\mathbf{r}), \quad (11.94)$$

where the signs \mp correspond to $q = \pm q_1$. We now write down an ansatz as a linear combination of solutions and show that it satisfies the Bogoliubov-de Gennes equation and the continuity conditions at the interface. The ansatz reads

$$\Psi(\mathbf{r}) = \begin{pmatrix} e^{i\mathbf{k}_1 \cdot \mathbf{r}} + r e^{i\tilde{\mathbf{k}}_1 \cdot \mathbf{r}} \\ a e^{i\mathbf{k}_2 \cdot \mathbf{r}} \end{pmatrix} \quad \text{for } x \leq 0, \quad (11.95)$$

with $\tilde{\mathbf{k}}_1 := (-k_{1x}, k_{1y}, k_{1z})$ and $\mathbf{k}_2 = (k_{2x}, k_{1y}, k_{1z})$ with $k_{2x} > 0$, where $k_{1x}^2 + k_{1\parallel}^2 = k_F^2 + 2mE$ and $k_{2x}^2 + k_{1\parallel}^2 = k_F^2 - 2mE$, and

$$\Psi(\mathbf{r}) = e^{-\kappa_1 x} \begin{pmatrix} \alpha_+ e^{i(q_1 x + k_{1y} y + k_{1z} z)} + \alpha_- e^{i(-q_1 x + k_{1y} y + k_{1z} z)} \\ \beta_+ e^{i(q_1 x + k_{1y} y + k_{1z} z)} + \beta_- e^{i(-q_1 x + k_{1y} y + k_{1z} z)} \end{pmatrix} \quad \text{for } x \geq 0. \quad (11.96)$$

Note that $\tilde{\mathbf{k}}_1$ is the wave vector of a specularly reflected electron. From Eq. (11.94) we get

$$\beta_{\pm} = \frac{E \mp i\sqrt{\Delta_0^2 - E^2}}{\Delta_0} \alpha_{\pm}. \quad (11.97)$$

From the continuity of Ψ_1, Ψ_2 , and their x -derivatives we obtain

$$1 + r = \alpha_+ + \alpha_-, \quad (11.98)$$

$$a = \beta_+ + \beta_-, \quad (11.99)$$

$$ik_{1x} - r ik_{1x} = \alpha_+(-\kappa_1 + iq_1) + \alpha_-(-\kappa_1 - iq_1), \quad (11.100)$$

$$a ik_{2x} = \beta_+(-\kappa_1 + iq_1) + \beta_-(-\kappa_1 - iq_1). \quad (11.101)$$

We thus have six coupled linear equations for the six unknown coefficients $r, a, \alpha_+, \alpha_-, \beta_+, \beta_-$. The equations are linearly independent so that they have a unique solution, which we can obtain by standard methods. The six coefficients are generally non-zero and complex. We do not give the lengthy expressions here but discuss the results physically.

- The solution in the superconductors decays exponentially, which is reasonable since the energy lies in the superconducting gap.
- In the normal region there is a specularly reflected electron wave (coefficient r), which is also expected. So far, the same results would be obtained for a simple potential step. However, explicit evaluation shows that generally $|r|^2 < 1$, i.e., not all electrons are reflected.
- There is also a term

$$\Psi_2(\mathbf{r}) = a e^{i\mathbf{k}_2 \cdot \mathbf{r}} \text{ for } x \leq 0. \quad (11.102)$$

Recall that the second spinor component was defined by

$$|\Psi_{\mathbf{k}_2}\rangle = c_{-\mathbf{k},\downarrow} |\psi_{\text{BCS}}\rangle. \quad (11.103)$$

Hence, the above term represents a spin-down hole with wave vector $-\mathbf{k}_2$. Now we have $\mathbf{k}_{2\parallel} = \mathbf{k}_{1\parallel}$, $k_{2x}^2 = k_F^2 - k_{1\parallel}^2 - 2mE$, and $k_{1x}^2 = k_F^2 - k_{1\parallel}^2 + 2mE$. But the last terms $\pm 2mE$ are small since

$$|E| < \Delta_0 \ll \mu = \frac{k_F^2}{2m} \quad (11.104)$$

in conventional superconductors. Thus $|k_{2x} - k_{1x}|$ is small and the hole is traveling nearly in the opposite direction compared to the incoming electron wave. This phenomenon is called *Andreev reflection*.

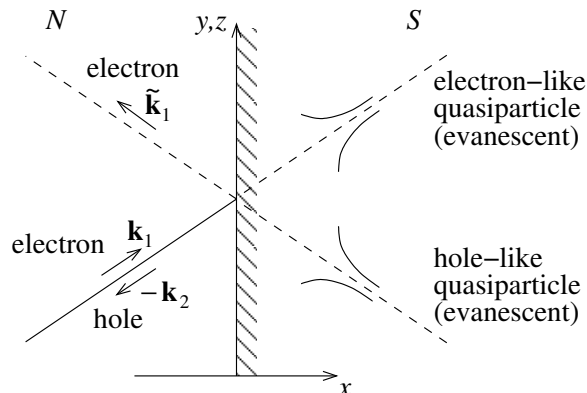

Since not all electrons are reflected and in addition some holes are generated, where does the missing charge go? The quasiparticle states in the superconductor are evanescent and thus cannot accommodate the missing charge. The only possible explanation is that the charge is added to the superconducting condensate, i.e., that additional Cooper pairs are formed. (The whole process can also run backwards, in which case Cooper pairs are removed.) Recall that the condensate does not have a sharp electron number and can therefore absorb or emit electrons without changing the state. But it can only absorb or emit electrons in pairs. The emerging picture is that if an incoming electron is not specularly reflected, a Cooper pair is created, which requires a second electron. This second electron is taken from the normal region, creating a hole, which, as we have seen, travels in the direction the original electron was coming from.

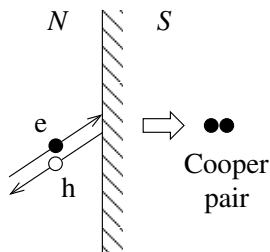

Andreev bound states

An interesting situation arises if a normal region is delimited by superconductors on two sides. We here only qualitatively consider a superconductor-normal-superconductor (SNS) heterostructure. Similar effects can also occur for example in the normal core of a vortex.

If no voltage is applied between the two superconductors an electron in the normal region, with energy within the gap, is Andreev reflected as a hole at one interface. It is then Andreev reflected as an electron at the other interface. It is plausible that multiple reflections can lead to the formation of bound states. The real physics is somewhat more complicated since the electron is also partially specularly reflected as an *electron*. It is conceptually clear, though, how to describe Andreev bound states within the Bogoliubov-de Gennes formalism: We just have to satisfy continuity conditions for both interfaces. We expect a discrete set of bound states to exist, in analogy to the finite square well in elementary quantum mechanics.

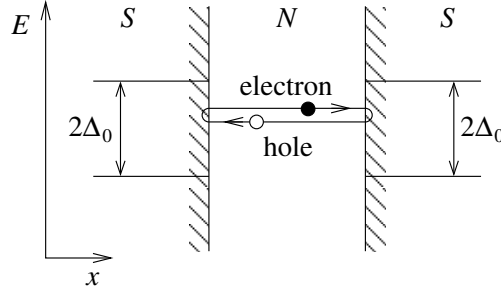

If Andreev reflection dominates, as assumed for the sketch above, a Cooper pair is emitted into the right superconductor for every reflection at the right interface. Conversely, a Cooper pair is absorbed from the left superconductor for every reflection at the left interface. This corresponds to a supercurrent through the device. Andreev bound states thus contribute to the Josephson effect in superconductor-normal-superconductor junctions.

If we apply a voltage V , the situation changes dramatically. The main insight was formulated by Klapwijk, Blonder, and Tinkham (1982). If an electron moving, say, to the right, increases its kinetic energy by eV due to the bias voltage, an Andreev reflected hole traveling to the left *also increases* its kinetic energy by eV since it carries the opposite charge. An electron/hole Andreev-reflected multiple times can thus gain arbitrarily high energies for any non-vanishing bias voltage.

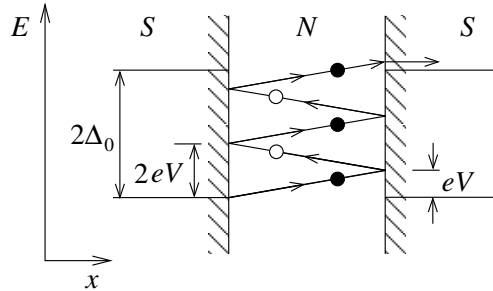

In particular, an electron-like quasiparticle from an occupied state below the gap in, say, the left superconductor can after multiple reflections emerge in a previously unoccupied state above the gap in the right superconductor. A new transport channel becomes available whenever the full gap $2\Delta_0$ is an odd integer multiple of eV :

$$2\Delta_0 = (2n + 1) eV, \quad n = 0, 1, \dots \quad (11.105)$$

$$\Rightarrow eV = \frac{\Delta_0}{n + \frac{1}{2}}, \quad n = 0, 1, \dots \quad (11.106)$$

If $2\Delta_0$ is an *even* multiple of eV a hole emerges above the gap in the left superconductor. At the gap edge, the Bogoliubov quasiparticles consist of equal parts electrons and holes. Hence, an incoming hole can just as easily be absorbed as an incoming electron. Thus, new transport channels actually open at all multiples of eV , i.e., at

$$2\Delta_0 = n eV, \quad n = 1, 2, \dots \quad (11.107)$$

$$\Rightarrow eV = \frac{2\Delta_0}{n}, \quad n = 1, 2, \dots \quad (11.108)$$

The case $n = 0$ corresponds to direct quasiparticle transfer from one superconductor to the other, similar to quasiparticle tunneling in a superconductor-insulator-superconductor junction.

The opening of new transport channels leads to structures in the current-voltage characteristics *below* the gap, specifically to peaks in the differential conductance dI/dV :

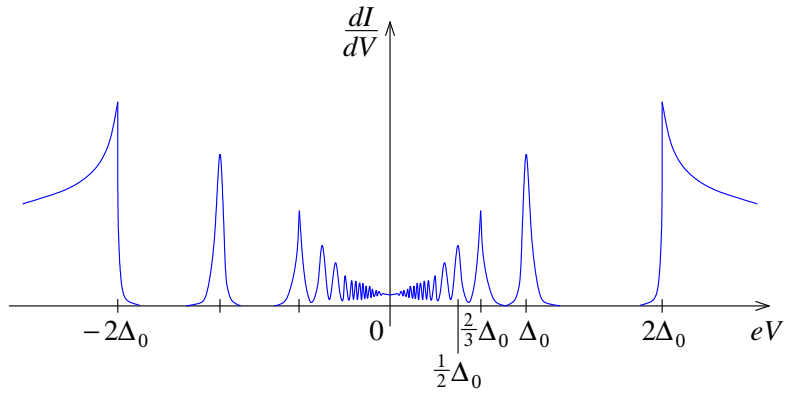

12

Unconventional pairing

In this chapter we first discuss why interactions different from the phonon-mediated one might lead to unconventional pairing, that is to a gap function $\Delta_{\mathbf{k}}$ with non-trivial symmetry. Then we will briefly consider the origin of such interactions.

12.1 The gap equation for unconventional pairing

We will still use the BCS gap equation even when discussing unconventional superconductors. While the BCS mean-field theory might not be quantitatively correct in such cases, it will give a clear understanding of why the gap $\Delta_{\mathbf{k}}$ can have non-trivial symmetry. To get started, we briefly review results from BCS theory. The phonon-mediated interaction was derived in Sec. 8.4,

$$V_{\text{eff}}^{\text{RPA}}(\mathbf{q}, i\nu_n) = V_C^{\text{RPA}}(\mathbf{q}, i\nu_n) \frac{(i\nu_n)^2}{(i\nu_n)^2 - \omega_{\mathbf{q}}^2(i\nu_n)}, \quad (12.1)$$

where V_C^{RPA} is the screened Coulomb interaction and $\omega_{\mathbf{q}}$ is the renormalized phonon dispersion. The retarded interaction at small frequencies is

$$V_{\text{eff}}^R(\mathbf{q}, i\nu_n) \cong 4\pi \frac{e^2}{q^2 + \kappa_s^2} \frac{\nu^2}{\nu^2 - \omega_{\mathbf{q}}^R(\nu)^2 + i0^+ \text{sgn } \nu}, \quad (12.2)$$

where κ_s is the inverse screening length. The behavior at small distances r and small but non-zero frequency ν is determined by V_{eff}^R at large q , where $\omega_{\mathbf{q}}$ can be approximated by the Debye frequency. The interaction is thus attractive at low but nonzero frequencies (because of the last factor) and decays like $1/r$ for small r . The interaction is strongest at the same site in a tight-binding model (the pole of $1/r$ is cut off by the finite extent of the atomic orbitals). In order to understand the physics, it makes sense to replace the interaction by a simplified one that is completely local (attractive Hubbard model) or, equivalently, constant in \mathbf{k} space, as we have done above. However, the BCS gap equation (10.40),

$$\Delta_{\mathbf{k}} = -\frac{1}{N} \sum_{\mathbf{k}'} V_{\mathbf{k}\mathbf{k}'} \frac{\Delta_{\mathbf{k}'}}{2E_{\mathbf{k}'}} [1 - 2n_F(E_{\mathbf{k}'})] \quad (12.3)$$

is in fact far more general. In the gap equation, $V_{\mathbf{k}\mathbf{k}'}$ describes the amplitude for scattering of two electrons with momenta \mathbf{k}' and $-\mathbf{k}'$ and opposite spins into states with momenta \mathbf{k} and $-\mathbf{k}$.

Let us first consider the case that the interaction is local in real space (flat in \mathbf{k} space) but repulsive. This would apply if the phonons were for some reason ineffective in overscreening the Coulomb interaction. Then we obtain

$$\Delta_{\mathbf{k}} = -\frac{1}{N} \sum_{\mathbf{k}'} V_0 \frac{\Delta_{\mathbf{k}'}}{2E_{\mathbf{k}'}} [1 - 2n_F(E_{\mathbf{k}'})] \quad (12.4)$$

with $V_0 > 0$. The right-hand side is clearly independent of \mathbf{k} so that we have $\Delta_{\mathbf{k}} = \Delta_0$ and can cancel a factor of Δ_0 if it is non-zero:

$$1 = -\frac{V_0}{N} \sum_{\mathbf{k}'} \frac{1 - 2n_F(E_{\mathbf{k}'})}{2E_{\mathbf{k}'}}. \quad (12.5)$$

But now the right-hand side is always negative. Consequently, there is no solution with $\Delta_0 \neq 0$ and thus no superconductivity for a \mathbf{k} -independent repulsion.

Now let us look at a strong interaction between nearest-neighbor sites. We consider a two-dimensional square lattice for simplicity and since it is thought to be a good model for the cuprates. In momentum space, a nearest-neighbor interaction is written as

$$V_{\mathbf{k}\mathbf{k}'} = 2V_1 [\cos(k_x - k'_x)a + \cos(k_y - k'_y)a], \quad (12.6)$$

where $V_1 > 0$ ($V_1 < 0$) for a repulsive (attractive) interaction.

It is now important to realize which terms in the momentum sum in the gap equation (12.3) are dominant. The factor $1 - n_F(E_{\mathbf{k}'})$ is on the order of unity since $E_{\mathbf{k}'} \geq |\Delta_{\mathbf{k}'}|$ and $|\Delta_{\mathbf{k}'}|/k_B T = \mathcal{O}(1)$. On the other hand, the factor $1/E_{\mathbf{k}'}$ is largest on the normal-state Fermi surface, where $E_{\mathbf{k}'} = |\Delta_{\mathbf{k}'}|$. We therefore concentrate on these states. The coupling to states away from the Fermi surface is additionally suppressed by the factor $\Delta_{\mathbf{k}'}/E_{\mathbf{k}'}$. This is a relatively weak, power-law suppression.

Let us first consider the repulsive case $V_1 > 0$. Then $V_{\mathbf{k}\mathbf{k}'}$ is most strongly repulsive (positive) for momentum transfer $\mathbf{k} - \mathbf{k}' \rightarrow 0$. But $\Delta_{\mathbf{k}}$ should be a smooth function of \mathbf{k} , thus for \mathbf{k} and \mathbf{k}' close together, $\Delta_{\mathbf{k}}$ and $\Delta_{\mathbf{k}'}$ are also similar. In particular, $\Delta_{\mathbf{k}}$ will rarely change its sign between \mathbf{k} and \mathbf{k}' . Consequently, the right-hand side of the gap equation always contains a large contribution with sign *opposite* to that of $\Delta_{\mathbf{k}}$, coming from the sum over \mathbf{k}' close to \mathbf{k} . Hence, a repulsive nearest-neighbor interaction is unlikely to lead to superconductivity.

For the attractive case, $V_1 < 0$, $V_{\mathbf{k}\mathbf{k}'}$ is most strongly attractive for $\mathbf{k} - \mathbf{k}' \rightarrow 0$ and most strongly repulsive for $\mathbf{k} - \mathbf{k}' \rightarrow (\pi/a, \pi/a)$ and other vectors related by lattice symmetries. The attraction at small $\mathbf{q} = \mathbf{k} - \mathbf{k}'$ is always favorable for superconductivity. However, we also have an equally strong repulsion around $\mathbf{q} \approx (\pi/a, \pi/a)$. A critical situation thus arises if both \mathbf{k} and \mathbf{k}' lie close to the Fermi surface and their difference is close to $(\pi/a, \pi/a)$. The central insight is that this can still help superconductivity if the gaps $\Delta_{\mathbf{k}}$ and $\Delta_{\mathbf{k}'}$ at \mathbf{k} and $\mathbf{k}' \approx \mathbf{k} + (\pi/a, \pi/a)$, respectively, have *opposite sign*. In this case the contribution to the right-hand side of the gap equation from such \mathbf{k}' has the same sign as $\Delta_{\mathbf{k}}$ since $V_{\mathbf{k}\mathbf{k}'} > 0$ and there is an explicit minus sign. Note that superconductivity can even be stabilized by a purely *repulsive* interaction around $\mathbf{q} \approx (\pi/a, \pi/a)$ if the interaction around $\mathbf{q} \approx 0$ is not too strongly repulsive. We will get back to this point shortly.

This effect is crucial for the cuprates, which do have an effective attractive nearest-neighbor interaction and have a large normal-state Fermi surface shown here for a two-dimensional model:

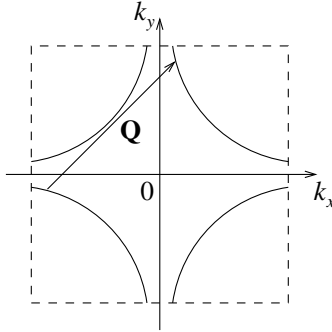

The vector \mathbf{Q} in the sketch is $\mathbf{Q} = (\pi/a, \pi/a)$. Following the previous discussion, $\Delta_{\mathbf{k}}$ close to the Fermi surface should have different sign between points separated by \mathbf{Q} . On the other hand, the small- \mathbf{q} attraction favors gaps $\Delta_{\mathbf{k}}$ that change sign “as little as possible.” By inspection, these conditions are met by a gap changing sign on the diagonals:

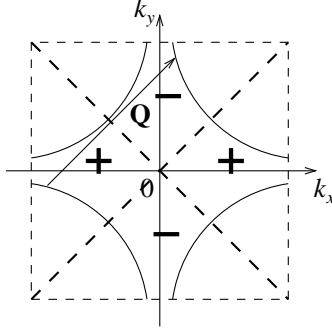

This type of gap is called a $d_{x^2-y^2}$ -wave (or just d -wave) gap since it has the symmetry of a $d_{x^2-y^2}$ -orbital (though in \mathbf{k} -space, not in real space). The simplest gap function with this symmetry and consistent with the lattice structure is

$$\Delta_{\mathbf{k}} = \Delta_0 (\cos k_x a - \cos k_y a). \quad (12.7)$$

Recall that the gap function away from the Fermi surface is of limited importance because there $E_{\mathbf{k}} \cong |\xi_{\mathbf{k}}|$. The d -wave gap $\Delta_{\mathbf{k}}$ also differs from the conventional, approximately constant s -wave gap in that it has zeros on the normal-state Fermi surface. These zeros are called (gap) nodes. In the present case, they appear in the (11) and equivalent directions. The quasiparticle dispersion in the vicinity of such a node is

$$E_{\mathbf{k}} = \sqrt{\xi_{\mathbf{k}}^2 + |\Delta_{\mathbf{k}}|^2} \cong \sqrt{(\epsilon_{\mathbf{k}} - \mu)^2 + \Delta_0^2 (\cos k_x a - \cos k_y a)^2}. \quad (12.8)$$

One node is at

$$\mathbf{k}_0 = \frac{k_F}{\sqrt{2}} \begin{pmatrix} 1 \\ 1 \end{pmatrix}. \quad (12.9)$$

Note that k_F depends on the direction in momentum space. Evidently, the $d_{x^2-y^2}$ -wave gap has *point nodes* for our two-dimensional model. For a three-dimensional system of layers with negligible coupling, the normal-state Fermi surface becomes a cylinder along the k_z direction and the nodes become straight lines in the same direction. If the dispersion along k_z is not negligible but still small the Fermi surface is deformed but retains the topology of a cylinder and the nodes remain lines where the Fermi surface intersect with the high-symmetry planes $k_y = \pm k_x$.

Writing $\mathbf{k} = \mathbf{k}_0 + \mathbf{q}$ and expanding for small \mathbf{q} , we obtain

$$E_{\mathbf{k}_0+\mathbf{q}} \cong \sqrt{(\mathbf{v}_F \cdot \mathbf{q})^2 + \Delta_0^2 [-(\sin k_x^0 a)q_x a + (\sin k_y^0 a)q_y a]^2}, \quad (12.10)$$

where

$$\mathbf{v}_F := \left. \frac{\partial \epsilon_{\mathbf{k}}}{\partial \mathbf{k}} \right|_{\mathbf{k}=\mathbf{k}_0} = \frac{v_F}{\sqrt{2}} \begin{pmatrix} 1 \\ 1 \end{pmatrix} \quad (12.11)$$

is the normal-state Fermi velocity at the node. Thus

$$E_{\mathbf{k}_0+\mathbf{q}} \cong \sqrt{(\mathbf{v}_F \cdot \mathbf{q})^2 + \Delta_0^2 \left[\left(-a \sin \frac{k_F a}{\sqrt{2}}, a \sin \frac{k_F a}{\sqrt{2}} \right) \cdot \mathbf{q} \right]^2} = \sqrt{(\mathbf{v}_F \cdot \mathbf{q})^2 + (\mathbf{v}_{\text{qp}} \cdot \mathbf{q})^2}, \quad (12.12)$$

where

$$\mathbf{v}_{\text{qp}} := \Delta_0 a \sin \frac{k_F a}{\sqrt{2}} \begin{pmatrix} -1 \\ 1 \end{pmatrix} \perp \mathbf{v}_F. \quad (12.13)$$

Thus the quasiparticle dispersion close to the node is a *cone* like for massless relativistic particles, but with different velocities in the directions normal and tangential to the Fermi surface. Usually one finds $v_{\text{qp}} \ll v_F$ since v_{qp} is controlled by $\Delta_0 \ll \mu$. The following sketch shows equipotential lines of $E_{\mathbf{k}}$.

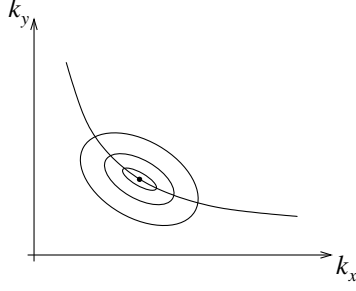

The fact that the gap closes at some \mathbf{k} points implies that the quasiparticle density of states does not have a gap. At low energies we can estimate it from our expansion of the quasiparticle energy,

$$\begin{aligned}
D_s(E) &= \frac{1}{N} \sum_{\mathbf{k}} \delta(E - E_{\mathbf{k}}) \\
&\cong \frac{4}{N} \sum_{\mathbf{q}} \delta\left(E - \sqrt{(\mathbf{v}_F \cdot \mathbf{q})^2 + (\mathbf{v}_{\text{qp}} \cdot \mathbf{q})^2}\right) \\
&= 4a_{\text{uc}} \int \frac{d^2q}{(2\pi)^2} \delta\left(E - \sqrt{(\mathbf{v}_F \cdot \mathbf{q})^2 + (\mathbf{v}_{\text{qp}} \cdot \mathbf{q})^2}\right) \\
&= \frac{4a_{\text{uc}}}{v_F v_{\text{qp}}} \int \frac{d^2u}{(2\pi)^2} \delta\left(E - \sqrt{u_x^2 + u_y^2}\right) \\
&= \frac{2a_{\text{uc}}}{\pi v_F v_{\text{qp}}} \int_0^\infty du u \delta(E - u) = \frac{2a_{\text{uc}}}{\pi v_F v_{\text{qp}}} E,
\end{aligned} \tag{12.14}$$

where a_{uc} is the area of the two-dimensional unit cell. We see that the density of states starts *linearly* at small energies. The full dependence is sketched in the following figure, where Δ_{max} is the maximum of $\Delta_{\mathbf{k}}$ for \mathbf{k} on the Fermi surface.

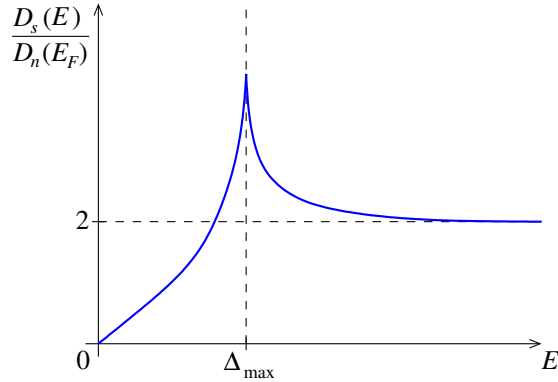

The linear instead of exponential temperature dependence at low T obviously leads to distinct thermodynamic properties. For example, the electronic contribution to the specific heat is not exponentially suppressed but a power law $c \sim T^2$.

An additional nice feature of the d -wave gap is the following: The interaction considered above is presumably not of BCS (Coulomb + phonons) type. However, there is also a strong short-range (local) Coulomb repulsion, which we here assume not to be overscreened by phonon exchange. This repulsion can again be modeled by a constant $V_0 > 0$ in \mathbf{k} -space. This additional interaction adds the term

$$-\frac{V_0}{N} \sum_{\mathbf{k}'} \frac{1 - 2n_F(E_{\mathbf{k}'})}{2E_{\mathbf{k}'}} \Delta_{\mathbf{k}'} \tag{12.15}$$

to the gap equation. But since $E_{\mathbf{k}'}$ does not change sign under rotation of \mathbf{k}' by $\pi/2$ (i.e., 90°), while $\Delta_{\mathbf{k}'}$ does change sign under this rotation, the sum over \mathbf{k}' vanishes. d -wave pairing is thus robust against on-site Coulomb repulsion.

12.2 Cuprates

Estimates of the critical temperature T_c of cuprates based on phonon-exchange and using experimentally known values of the Debye frequency, the electron-phonon coupling, and the normal-state density of states are much lower than the observed critical temperatures. Also, as we have seen, such an interaction tends to be flat in \mathbf{k} -space, which favors an s -wave gap. An s -wave gap is inconsistent with nearly all pertinent experiments on the cuprates. The last section has shown that $d_{x^2-y^2}$ -wave pairing in the cuprates is plausible *if* there is a *repulsive* interaction for momentum transfers $\mathbf{q} \approx (\pi/a, \pi/a)$. We will now discuss the possible origin of this attraction.

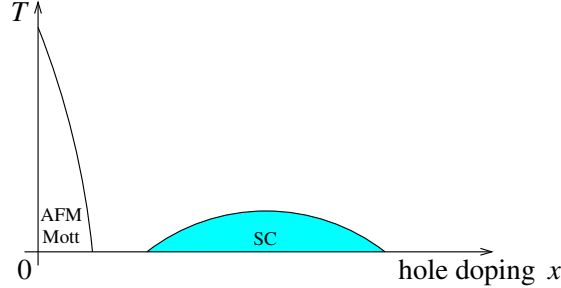

A glance at typical phase diagrams shows that the undoped cuprates tend to be antiferromagnetic. Weak hole doping or slightly stronger electron doping destroy the antiferromagnetic order, and at larger doping, superconductivity emerges. At even larger doping (the “overdoped” regime), superconductivity is again suppressed. Also in many other unconventional superconductors superconductivity is found in the vicinity of, but rarely coexisting with, magnetic order. This is true for most pnictide and heavy-fermion superconductors. The vicinity of a magnetically ordered phase makes itself felt by strong magnetic fluctuations and strong, but short-range, spin correlations. These are reflected by an enhanced spin susceptibility.

At a magnetic second-order phase transition, the static spin susceptibility $\chi_{\mathbf{q}}(\nu = 0)$ diverges at $\mathbf{q} = \mathbf{Q}$, where \mathbf{Q} is the ordering vector. It is $\mathbf{Q} = 0$ for ferromagnetic order and $\mathbf{Q} = (\pi/a, \pi/a)$ for checkerboard (Néel) order on a square lattice. Even some distance from the transition or at non-zero frequencies ν , the susceptibility $\chi_{\mathbf{q}}(\nu)$ tends to have a maximum close to \mathbf{Q} . Far away from the magnetic phase or at high frequencies this remnant of magnetic order becomes small. This discussion suggests that the exchange of spin fluctuations, which are strong close to \mathbf{Q} , could provide the attractive interaction needed for Cooper pairing.

The Hubbard model

The two-dimensional, single-band, repulsive Hubbard model is thought (by many experts but not by everyone) to be the simplest model that captures the principal physics of the cuprates. The Hamiltonian reads, in real space,

$$H = - \sum_{ij\sigma} t_{ij} c_{i\sigma}^\dagger c_{j\sigma} + U \sum_i c_{i\uparrow}^\dagger c_{i\uparrow} c_{i\downarrow}^\dagger c_{i\downarrow} \quad (12.16)$$

with $U > 0$ and, in momentum space,

$$H = \sum_{\mathbf{k}\sigma} \xi_{\mathbf{k}} c_{\mathbf{k}\sigma}^\dagger c_{\mathbf{k}\sigma} + \frac{U}{N} \sum_{\mathbf{k}\mathbf{k}'\mathbf{q}} c_{\mathbf{k}+\mathbf{q},\uparrow}^\dagger c_{\mathbf{k}'-\mathbf{q},\downarrow}^\dagger c_{\mathbf{k}'\downarrow} c_{\mathbf{k}\uparrow}, \quad (12.17)$$

where the chemical potential was absorbed into the dispersion $\xi_{\mathbf{k}} = \epsilon_{\mathbf{k}} - \mu$. The Hubbard (U) term approximates the screened Coulomb repulsion, assuming that screening makes the non-local repulsion negligibly small. The underlying lattice in real space is a two-dimensional square lattice with each site i corresponding to a Cu^+ ion.

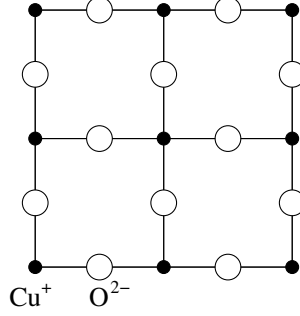

The undoped cuprate parent compounds have, from simple counting, an odd number of electrons per unit cell. Thus for them the single band must be half-filled, while for doped cuprates it is still close to half filling. The anti-ferromagnetic parent compounds are nevertheless insulators. This is attributed to the strong Hubbard interaction U , i.e., they are *Mott insulators*.

The transverse spin susceptibility is defined by

$$\chi^{+-}(\mathbf{q}, \tau) = -\langle T_\tau S^+(\mathbf{q}, \tau) S^-(\mathbf{-q}, 0) \rangle, \quad (12.18)$$

where τ is the imaginary time, T_τ is the time-ordering directive, and

$$S^\pm(\mathbf{q}, \tau) := S^x(\mathbf{q}, \tau) \pm iS^y(\mathbf{q}, \tau) \quad (12.19)$$

with

$$S^\alpha(\mathbf{q}, \tau) := \frac{1}{\sqrt{N}} \sum_{\mathbf{k}\sigma\sigma'} c_{\mathbf{k}+\mathbf{q},\sigma}^\dagger(\tau) \frac{\sigma_{\sigma\sigma'}^\alpha}{2} c_{\mathbf{k}\sigma'}(\tau) \quad (12.20)$$

are electron-spin operators. $\boldsymbol{\sigma} = (\sigma^x, \sigma^y, \sigma^z)$ is the vector of Pauli matrices. The susceptibility can be rewritten as

$$\chi^{+-}(\mathbf{q}, \tau) = -\frac{1}{N} \sum_{\mathbf{k}\mathbf{k}'} \langle T_\tau (c_{\mathbf{k}+\mathbf{q},\uparrow}^\dagger c_{\mathbf{k}\downarrow})(\tau) (c_{\mathbf{k}'-\mathbf{q},\downarrow}^\dagger c_{\mathbf{k}'\uparrow})(0) \rangle. \quad (12.21)$$

In the non-interacting limit of $U \rightarrow 0$, the average of four fermionic operators can be written in terms of products of averages of two operators (Wick's theorem). The resulting *bare* susceptibility reads

$$\begin{aligned} \chi_0^{+-}(\mathbf{q}, \tau) &= -\frac{1}{N} \sum_{\mathbf{k}} \langle T_\tau c_{\mathbf{k}+\mathbf{q},\uparrow}^\dagger(\tau) c_{\mathbf{k}+\mathbf{q},\uparrow}(0) \rangle_0 \langle T_\tau c_{\mathbf{k}\downarrow}(\tau) c_{\mathbf{k}\downarrow}^\dagger(0) \rangle_0 \\ &= \frac{1}{N} \sum_{\mathbf{k}} \langle T_\tau c_{\mathbf{k}+\mathbf{q},\uparrow}(0) c_{\mathbf{k}+\mathbf{q},\uparrow}^\dagger(\tau) \rangle_0 \langle T_\tau c_{\mathbf{k}\downarrow}(\tau) c_{\mathbf{k}\downarrow}^\dagger(0) \rangle_0 \\ &= \frac{1}{N} \sum_{\mathbf{k}} \mathcal{G}_{\mathbf{k}+\mathbf{q},\uparrow}^0(-\tau) \mathcal{G}_{\mathbf{k}\downarrow}^0(\tau). \end{aligned} \quad (12.22)$$

The Fourier transform as a function of the bosonic Matsubara frequency $i\nu_n$ is

$$\begin{aligned} \chi_0^{+-}(\mathbf{q}, i\nu_n) &= \int_0^\beta d\tau e^{i\nu_n\tau} \chi_0^{+-}(\mathbf{q}, \tau) \\ &= \frac{1}{N} \int_0^\beta d\tau e^{i\nu_n\tau} \sum_{\mathbf{k}} \frac{1}{\beta} \sum_{i\omega'_n} e^{-i\omega'_n(-\tau)} \mathcal{G}_{\mathbf{k}+\mathbf{q},\uparrow}^0(i\omega'_n) \frac{1}{\beta} \sum_{i\omega_n} e^{-i\omega_n\tau} \mathcal{G}_{\mathbf{k}\downarrow}^0(i\omega_n) \\ &= \frac{1}{N} \sum_{\mathbf{k}} \frac{1}{\beta^2} \sum_{i\omega_n, i\omega'_n} \beta \delta_{\nu_n + \omega'_n, \omega_n} \mathcal{G}_{\mathbf{k}+\mathbf{q},\uparrow}^0(i\omega'_n) \mathcal{G}_{\mathbf{k}\downarrow}^0(i\omega_n) = \frac{1}{N} \sum_{\mathbf{k}} \frac{1}{\beta} \sum_{i\omega_n} \mathcal{G}_{\mathbf{k}+\mathbf{q},\uparrow}^0(i\omega_n - i\nu_n) \mathcal{G}_{\mathbf{k}\downarrow}^0(i\omega_n) \\ &= \frac{1}{N} \sum_{\mathbf{k}} \frac{1}{\beta} \sum_{i\omega_n} \frac{1}{i\omega_n - i\nu_n - \xi_{\mathbf{k}+\mathbf{q}}} \frac{1}{i\omega_n - \xi_{\mathbf{k}}}. \end{aligned} \quad (12.23)$$

This expression can be written in a more symmetric form concerning the appearing momenta and frequencies by making use of the identity $\xi_{\mathbf{k}} = \xi_{-\mathbf{k}}$ and replacing the summation variables \mathbf{k} by $-\mathbf{k} - \mathbf{q}$ and $i\omega_n$ by $i\omega_n + i\nu_n$. The result is

$$\chi_0^{+-}(\mathbf{q}, i\nu_n) = \frac{1}{N} \sum_{\mathbf{k}} \frac{1}{\beta} \sum_{i\omega_n} \frac{1}{i\omega_n - \xi_{\mathbf{k}}} \frac{1}{i\omega_n + i\nu_n - \xi_{\mathbf{k}+\mathbf{q}}}. \quad (12.24)$$

The Matsubara frequency sum can be evaluated using methods from complex analysis (contour integration, residue theorem). We here give the result without proof,

$$\chi_0^{+-}(\mathbf{q}, i\nu_n) = \frac{1}{N} \sum_{\mathbf{k}} \frac{n_F(\xi_{\mathbf{k}}) - n_F(\xi_{\mathbf{k}+\mathbf{q}})}{i\nu_n + \xi_{\mathbf{k}} - \xi_{\mathbf{k}+\mathbf{q}}}. \quad (12.25)$$

Note that the same result is found for the bare charge susceptibility except for a spin factor of 2. Diagrammatically, the result can be represented by the bubble diagram, introduced in Sec. 8.2,

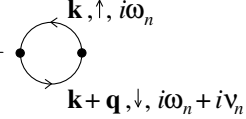
$$\chi_0^{+-}(\mathbf{q}, i\nu_n) = -\frac{1}{2} \Pi_0(\mathbf{q}, i\nu_n) = - \text{bubble diagram} \quad (12.26)$$

What changes when we switch on the Hubbard interaction U ? In analogy to the RPA theory for the screened Coulomb interaction we might guess that the RPA spin susceptibility is given by

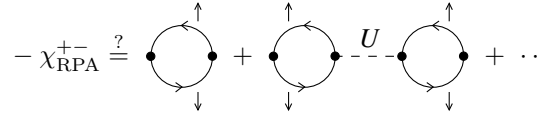
$$-\chi_{\text{RPA}}^{+-} \stackrel{?}{=} \text{bubble diagram} + \text{bubble diagram} - U \text{bubble diagram} + \dots \quad (12.27)$$

but the second and higher terms vanish since they contain vertices at which the Hubbard interaction supposedly flips the spin,

$$\text{vertex diagram} - U \text{dashed line}, \quad (12.28)$$

which it cannot do. On the other hand, the following ladder diagrams do not vanish and represent the RPA susceptibility:

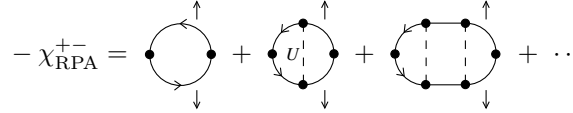
$$-\chi_{\text{RPA}}^{+-} = \text{bubble diagram} + \text{bubble diagram with U} + \text{bubble diagram with U} + \dots \quad (12.29)$$

Since the Hubbard interaction does not depend on momentum, this series has a rather simple mathematical form,

$$\begin{aligned} \chi_{\text{RPA}}^{+-}(\mathbf{q}, i\nu_n) &= \chi_0^{+-}(\mathbf{q}, i\nu_n) + \chi_0^{+-}(\mathbf{q}, i\nu_n) U \chi_0^{+-}(\mathbf{q}, i\nu_n) + \chi_0^{+-}(\mathbf{q}, i\nu_n) U \chi_0^{+-}(\mathbf{q}, i\nu_n) U \chi_0^{+-}(\mathbf{q}, i\nu_n) + \dots \\ &= \chi_0^{+-}(\mathbf{q}, i\nu_n) [1 + U \chi_0^{+-}(\mathbf{q}, i\nu_n) + U \chi_0^{+-}(\mathbf{q}, i\nu_n) U \chi_0^{+-}(\mathbf{q}, i\nu_n) + \dots] \\ &= \frac{\chi_0^{+-}(\mathbf{q}, i\nu_n)}{1 - U \chi_0^{+-}(\mathbf{q}, i\nu_n)} \end{aligned} \quad (12.30)$$

[the signs in the first line follow from the Feynman rules, in particular each term contains a single fermionic loop, which gives a minus sign, which cancels the explicit one in Eq. (12.29)]. The RPA spin susceptibility can be evaluated numerically for given dispersion $\xi_{\mathbf{k}}$. It is clear that it predicts an instability of the Fermi liquid if the static RPA spin susceptibility

$$\chi_{\text{RPA}}^{+-,R}(\mathbf{q}, 0) = \chi_{\text{RPA}}^{+-}(\mathbf{q}, i\nu_n \rightarrow \nu + i0^+) |_{\nu \rightarrow 0} \equiv \frac{\chi_0^{+-,R}(\mathbf{q}, 0)}{1 - U \chi_0^{+-,R}(\mathbf{q}, 0)} \quad (12.31)$$

diverges at some $\mathbf{q} = \mathbf{Q}$, i.e., if

$$U \chi_0^{+-,R}(\mathbf{Q}, 0) = 1. \quad (12.32)$$

Since the *spin* susceptibility diverges, this would be a magnetic ordering transition with ordering vector \mathbf{Q} . Note that the RPA is not a good theory for the antiferromagnetic transition of the cuprates since it is a resummation of a perturbative series in U/t , which is not small in cuprates. t is the typical hopping amplitude. Nevertheless it gives qualitatively reasonable results in the paramagnetic phase, which is of interest for superconductivity.

The numerical evaluation in the paramagnetic phase at intermediate doping and not too low temperatures gives a broad and high peak in $\chi_{\text{RPA}}^{+-,R}(\mathbf{q}, 0)$ centered at $\mathbf{Q} = (\pi/a, \pi/a)$. This is consistent with the ordering at the same \mathbf{Q} observed at weak doping.

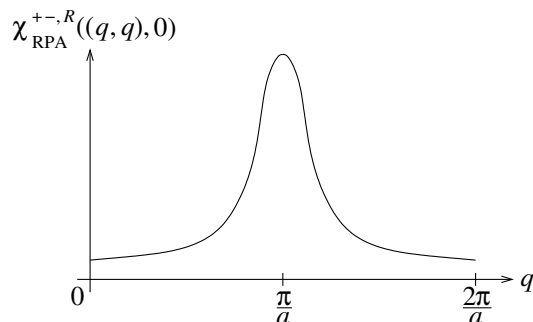

At lower temperatures, details become resolved that are obscured by thermal broadening at high T . The RPA and also more advanced approaches are very sensitive to the electronic bands close to the Fermi energy; states with $|\xi_{\mathbf{k}}| \gg k_B T$ have exponentially small effect on the susceptibility. Therefore, the detailed susceptibility at low T strongly depends on details of the model Hamiltonian. Choosing nearest-neighbor and next-nearest-neighbor hopping in such a way that a realistic Fermi surface emerges, one obtains a spin susceptibility with *incommensurate* peaks at $\frac{\pi}{a}(1, 1 \pm \delta)$ and $\frac{\pi}{a}(1 \pm \delta, 1)$.

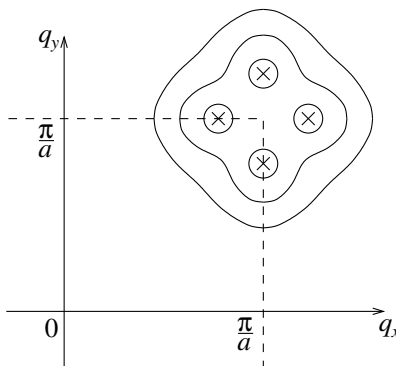

These peaks are due to *nesting*: Scattering is enhanced between parallel portions of the Fermi surface, which in turn enhances the susceptibility [see M. Norman, Phys. Rev. B **75**, 184514 (2007)].

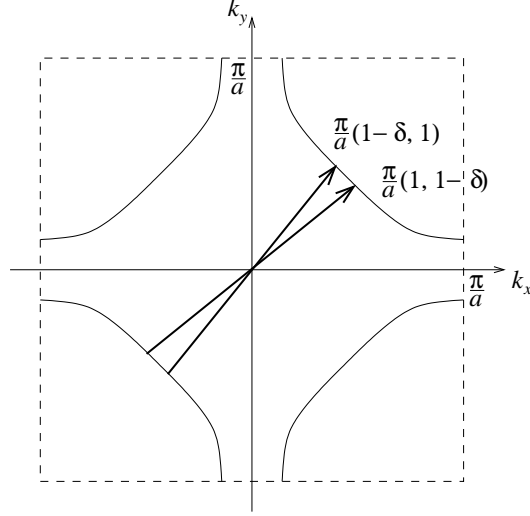

The results for the spin susceptibility are in qualitative agreement with neutron-scattering experiments. However, the RPA overestimates the tendency toward magnetic order, which is rectified by more advanced approaches.

Spin-fluctuation exchange

The next step is to construct an effective electron-electron interaction mediated by the exchange of spin fluctuations. The following diagrammatic series represents the simplest way of doing this, though certainly not the only one:

$$V_{\text{eff}} := \begin{array}{c} \uparrow \downarrow \\ \bullet \bullet \\ \parallel \\ \bullet \bullet \\ \downarrow \uparrow \end{array} := \begin{array}{c} \uparrow \downarrow \\ \bullet \bullet \\ \diagdown \diagup \\ U \\ \diagup \diagdown \\ \bullet \bullet \\ \downarrow \uparrow \end{array} + \begin{array}{c} \uparrow \downarrow \\ \bullet \bullet \\ \text{---} \\ \bullet \bullet \\ \diagdown \diagup \\ \bullet \bullet \\ \diagup \diagdown \\ \bullet \bullet \\ \downarrow \uparrow \end{array} + \begin{array}{c} \uparrow \downarrow \\ \bullet \bullet \\ \text{---} \\ \bullet \bullet \\ \text{---} \\ \bullet \bullet \\ \diagdown \diagup \\ \bullet \bullet \\ \diagup \diagdown \\ \bullet \bullet \\ \downarrow \uparrow \end{array} + \dots \quad (12.33)$$

V_{eff} flips the electron spins, indicating that it is indeed due to magnetic fluctuations. (As a technical remark, note that the external legs do not represent electronic Green functions but only indicate the states of incoming and outgoing electrons.) The series is very similar to the one for the RPA susceptibility. Indeed, the effective interaction is

$$\begin{aligned} V_{\text{eff}}(\mathbf{q}, i\nu_n) &= U + U\chi_0^{+-}(\mathbf{q}, i\nu_n)U + U\chi_0^{+-}(\mathbf{q}, i\nu_n)U\chi_0^{+-}(\mathbf{q}, i\nu_n)U + \dots \\ &= U + U^2 [\chi_0^{+-}(\mathbf{q}, i\nu_n) + \chi_0^{+-}(\mathbf{q}, i\nu_n)U\chi_0^{+-}(\mathbf{q}, i\nu_n) + \dots] \\ &= U + U^2 \chi_{\text{RPA}}^{+-}(\mathbf{q}, i\nu_n). \end{aligned} \quad (12.34)$$

Typically, one goes beyond the RPA at this point by including additional diagrams. In particular, also charge fluctuations are included through the charge susceptibility and the bare Green function \mathcal{G}^0 is replaced by a selfconsistent one incorporating the effect of spin and charge fluctuations on the electronic self-energy. This leads to the *fluctuation-exchange approximation (FLEX)*. One could now obtain the Cooper instability due to the RPA or FLEX effective interaction in analogy to Sec. 9.1 and use a BCS mean-field theory to describe the superconducting state. However, since the effective interaction has a nontrivial frequency dependence, one usually employs an extension of BCS theory that includes the full frequency dependence, known as *Eliashberg theory*. It is typically more successful than BCS theory if the interaction is not weak (i.e., the typical interaction times the electronic density of states is not small). Since the effective interaction is, like the spin susceptibility, strongly peaked close to $(\pi/a, \pi/a)$ and repulsive, it favors $d_{x^2-y^2}$ -wave pairing, as we have seen.

The numerical result of the FLEX for T_c and for the superfluid density n_s are sketched here:

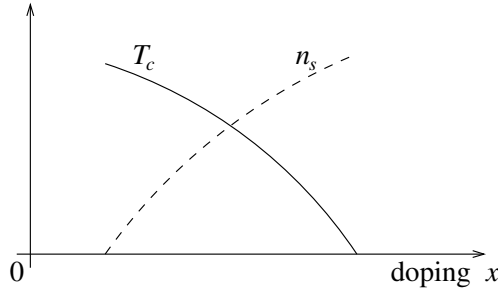

The increase of T_c toward low doping is reasonable, in principle: Superconductivity is driven by spin fluctuations, which are enhanced as one approaches the antiferromagnetic phase transition. However, the monotonous increase of T_c for decreasing doping does not agree with the experimentally observed dome. There are several aspects that make the region of low doping (underdoping) difficult to treat theoretically. One is indicated in the sketch: n_s is strongly reduced, which indicates that superconductivity may be in some sense fragile in this regime. Furthermore, the cuprates are nearly two-dimensional solids. In fact we have used a two-dimensional model so far. If we take this seriously, we know from chapter 7 that any mean-field theory, which Eliashberg theory with FLEX effective interaction still is, fails even qualitatively. Instead, we expect a BKT transition at a reduced critical temperature. We now interpret the FLEX critical temperature as the mean-field temperature T_{MF} and the FLEX superfluid density as the unrenormalized superfluid density n_s^0 . We have seen in chapter 7 that the bare stiffness K_0 is proportional to n_s^0 . The BKT transition temperature T_c is defined by $K(l \rightarrow \infty) = 2/\pi$. It is thus reduced by small n_s^0 , corresponding to a small initial value $K(0) \equiv K_0$. This is physically clear: a small stiffness makes it easy to create vortex-antivortex pairs. The real cuprates are three-dimensional materials, although the hopping in the direction normal to the CuO_2 planes is small. For this reason, and also because of the coupling to the electromagnetic field discussed in Sec. 7.2, the behavior close to the transition is not described by BKT theory. However, BKT theory does give a reasonable estimate for the doping dependence of the critical temperature T_c in the underdoped regime.

T_c is of course also limited by T_{MF} —it can never be larger than T_{MF} —which is most important in the overdoped regime. A BKT theory on top of the FLEX gives the following phase diagram, which is in qualitative agreement with experiments:

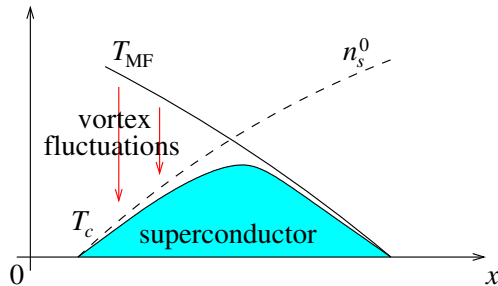

This scenario is consistent with the Nernst effect (an electric field measured normal to both an applied magnetic field and a temperature gradient) in underdoped cuprates, which is interpreted in terms of free vortices in a broad temperature range, which we would understand as the range from T_c to T_{MF} .

Also note that spin fluctuations strongly affect the electronic properties in underdoped cuprates up to a temperature T^* significantly higher than T_{MF} . For example, below T^* the electronic density of states close to the Fermi energy is suppressed compared to the result of band-structure calculations. The FLEX describes this effect qualitatively correctly. This suppression is the well-known but not well-understood *pseudogap*.

Quantum critical point

The previously discussed approach relies on a resummation of a perturbative series in U/t . This is questionable for cuprates, where U/t is on the order of 3. Many different approaches have been put forward that supposedly work in this strong-coupling regime. They emphasize different aspects of the cuprates, showing that it is not even

clear which ingredients are the most important for understanding the phase diagram. Here we will review a line of thought represented by Chandra Varma and Subir Sachdev, among others. Its starting point is an analysis of the *normal* region of the phase diagram.

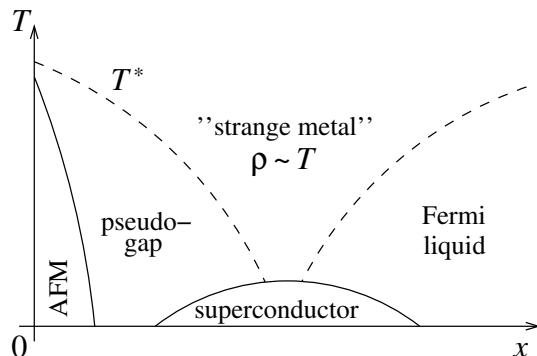

Roughly speaking, there are three regimes in the normal-conducting state:

- a pseudo-gap regime below T^* at underdoping, in which the electronic density of states at low energies is suppressed,
- a “strange-metal” regime above the superconducting dome, without a clear suppression of the density of states but with unusual temperature and energy dependencies of various observables, for example a resistivity linear in temperature, $\rho \propto T$,
- an apparently ordinary normal-metal (Fermi-liquid) regime at overdoping, with standard $\rho \propto \text{const} + T^2$ dependence.

The two crossover lines look very much like what one expects to find for a *quantum critical point* (QCP), i.e., a phase transition at zero temperature.

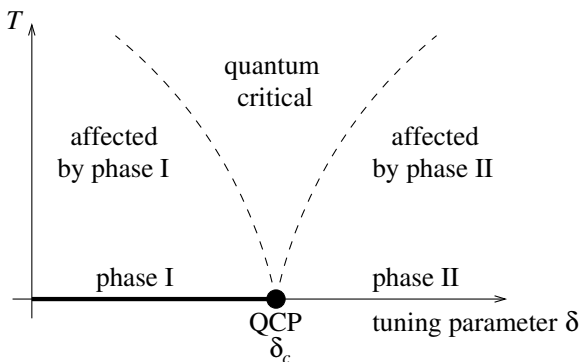

The regions to the left and right have a characteristic energy scale $\epsilon(\delta)$ inherited from the respective ground state (at $T = 0$), which dominates the thermal fluctuations. The energy scales go to zero at the QCP, i.e., for $\delta \rightarrow \delta_c$ from both sides. Right at the QCP there then is no energy scale and energy or temperature-dependent quantities have to be power laws. The emerging idea is that the superconducting dome hides a QCP between antiferromagnetic (spin-density-wave) and paramagnetic order at $T = 0$. The spin fluctuations associated with this QCP become stronger as it is approached. Consequently, the superconductivity caused by them is strongest and has the highest T_c right above the QCP. However, it is not immediately clear why antiferromagnetic long-range order appears to be suppressed already at very weak doping, while the QCP is located in the middle of the superconducting dome. Compare the previous argument: There, the spin fluctuations are assumed to be strongest close to the (finite-temperature) antiferromagnetic phase and one needs to invoke small n_s and vortex fluctuations to argue why the maximum T_c is not close to the antiferromagnetic phase.

12.3 Pnictides

The iron pnictide superconductors are a more heterogeneous group than the cuprates. However, for most of them the phase diagram is roughly similar to the one of a typical cuprate in that superconductivity emerges at finite doping in the vicinity of an antiferromagnetic phase. This antiferromagnetic phase is metallic, not a Mott insulator, though, suggesting that interactions are generally weaker in the pnictides.

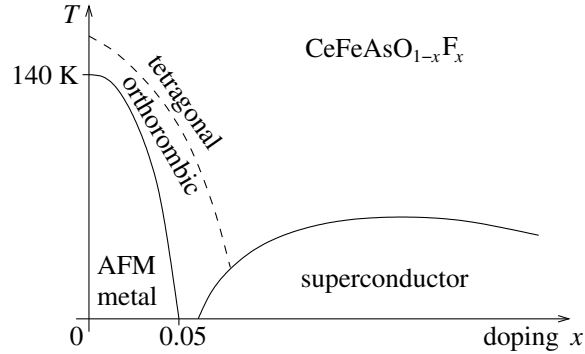

The crystal structure is quasi-two-dimensional, though probably less so than in the cuprates. The common structural motif is an iron-pnictogen, in particular $\text{Fe}^{2+}\text{As}^{3-}$, layer with Fe^{2+} forming a square lattice and As^{3-} sitting alternately above and below the Fe^{2+} plaquettes.

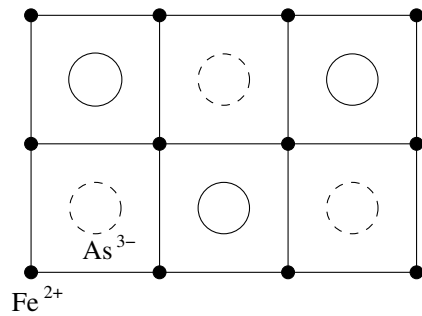

While the correct unit cell contains two As and two Fe ions, the glide-mirror symmetry with respect to the Fe plane allows to formulate two-dimensional (but not three-dimensional) models using a *single-iron* unit cell. The fact that different unit cells are used leads to some confusion in the field. Note that since the single-iron unit cell is *half* as large as the two-iron unit cell, the corresponding single-iron Brillouin zone is *twice* as large as the two-iron Brillouin zone.

A look at band-structure calculations or ARPES data shows that the Fermi surface of pnictides is much more complicated than the one of cuprates. The $k_z = 0$ cut typically shows four or five Fermi pockets; the small pocket at the M point may be absent.

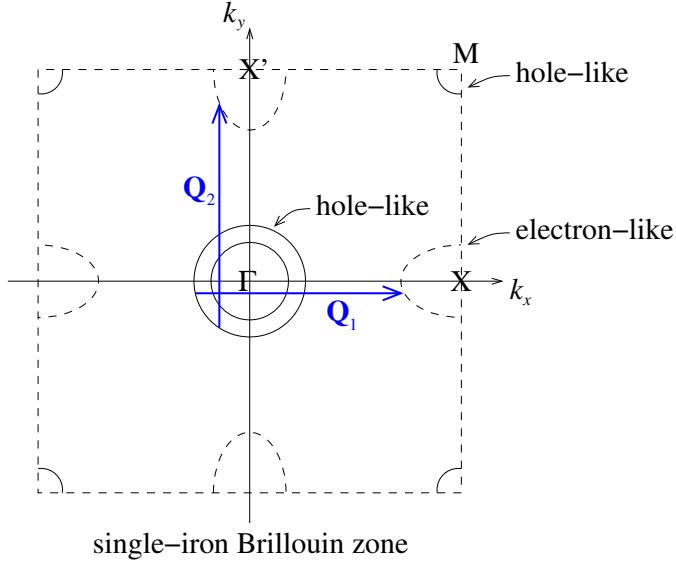

The (probably outer) hole pocket at Γ and the electron pockets at X and X' are well nested with nesting vectors $\mathbf{Q}_1 = (\pi/a, 0)$ and $\mathbf{Q}_2 = (0, \pi/a)$, respectively. Not surprisingly, the spin susceptibility is peaked at \mathbf{Q}_1 and \mathbf{Q}_2 in the paramagnetic phase and in the antiferromagnetic phase the system orders antiferromagnetically at either of three vectors, i.e., stripe like. Incidentally, the antiferromagnet emerges through the formation and condensation of electron-hole pairs (*excitons*), described by a BCS-type theory. The same excitonic instability is for example responsible for the magnetism of chromium.

Assuming that the exchange of spin fluctuations in the paramagnetic phase is the main pairing interaction, the gap equation

$$\Delta_{\mathbf{k}} = -\frac{1}{N} \sum_{\mathbf{k}'} V_{\mathbf{k}\mathbf{k}'} \frac{1 - 2n_F(E_{\mathbf{k}'})}{2E_{\mathbf{k}'}} \Delta_{\mathbf{k}'}, \quad (12.35)$$

with $V_{\mathbf{k}\mathbf{k}'}$ large and positive for $\mathbf{k} - \mathbf{k}' = \pm\mathbf{Q}_1$ or $\pm\mathbf{Q}_2$, favors a gap function $\Delta_{\mathbf{k}}$ that changes sign between \mathbf{k} and $\mathbf{k} + \mathbf{Q}_1$ and between \mathbf{k} and $\mathbf{k} + \mathbf{Q}_2$, following the general discussion in Sec. 12.1. This is most easily accommodated by a nodeless gap changing sign between the electron and hole pockets:

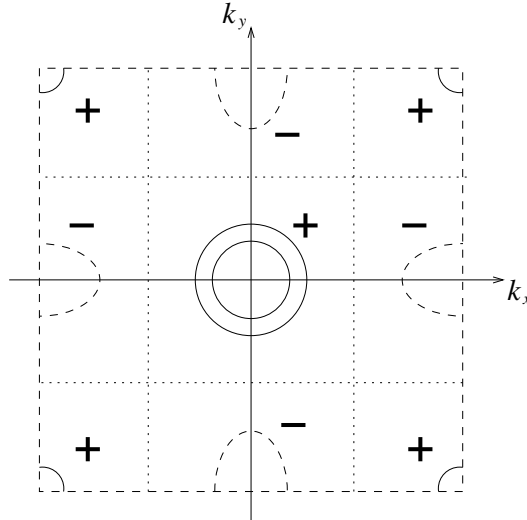

This gap has *s*-wave symmetry since it does not show lower symmetry than the lattice, unlike *d*-wave. To

emphasize the sign change, it is often called an s_{\pm} -wave (or s_{+-} -wave) gap. The simplest realization reads

$$\Delta_{\mathbf{k}} = \Delta_0 \cos k_x a \cos k_y a. \quad (12.36)$$

12.4 Triplet superconductors and He-3

So far, we have assumed that Cooper pairs are formed by two electrons with opposite spin so that the total spin of the pair vanishes (spin-singlet pairing). This assumption becomes questionable in the presence of strong *ferromagnetic* interactions, which favor parallel spin alignment. If superconductivity is possible at all in such a situation, we could expect to find spin-1 Cooper pairs. Since they would be spin triplets, one is talking of *triplet superconductors*. This scenario is likely realized for a few organic salts and certain heavy-fermion compounds such as UPt₃. Furthermore, it has long been favored for Sr₂RuO₄, which is, interestingly, isostructural to the prototypical cuprate La₂CuO₄. Recent experiments indicate, however, that the situation might be more complicated. A triplet pairing state is more certain to be responsible for the superfluidity of He-3, where neutral He-3 atoms instead of charged electrons form Cooper pairs, see Sec. 2.2.

Formally, we restrict ourselves to a BCS-type mean-field theory. We generalize the effective interaction to allow for an arbitrary spin dependence,

$$H = \sum_{\mathbf{k}\sigma} \xi_{\mathbf{k}} c_{\mathbf{k}\sigma}^{\dagger} c_{\mathbf{k}\sigma} + \frac{1}{N} \sum_{\mathbf{k}\mathbf{k}'} \sum_{\sigma\tau\sigma'\tau'} V_{\sigma\tau\sigma'\tau'}(\mathbf{k}, \mathbf{k}') c_{\mathbf{k}\sigma}^{\dagger} c_{-\mathbf{k},\tau}^{\dagger} c_{-\mathbf{k}',\tau'} c_{\mathbf{k}'\sigma'}, \quad (12.37)$$

where $\sigma, \tau, \sigma', \tau' = \uparrow, \downarrow$ are spin indices. In decomposing the interaction, we now allow the averages $\langle c_{-\mathbf{k},\tau} c_{\mathbf{k}\sigma} \rangle$ to be non-zero for all τ, σ . Thus the mean-field Hamiltonian reads

$$H_{\text{MF}} = \sum_{\mathbf{k}\sigma} \xi_{\mathbf{k}} c_{\mathbf{k}\sigma}^{\dagger} c_{\mathbf{k}\sigma} + \frac{1}{N} \sum_{\mathbf{k}\mathbf{k}'} \sum_{\sigma\tau\sigma'\tau'} V_{\sigma\tau\sigma'\tau'}(\mathbf{k}, \mathbf{k}') \left(\langle c_{\mathbf{k}\sigma}^{\dagger} c_{-\mathbf{k},\tau}^{\dagger} \rangle c_{-\mathbf{k}',\tau'} c_{\mathbf{k}'\sigma'} + c_{\mathbf{k}\sigma}^{\dagger} c_{-\mathbf{k},\tau}^{\dagger} \langle c_{-\mathbf{k}',\tau'} c_{\mathbf{k}'\sigma'} \rangle \right) + \text{const.} \quad (12.38)$$

We define

$$\Delta_{\sigma\tau}(\mathbf{k}) := -\frac{1}{N} \sum_{\mathbf{k}'} \sum_{\sigma'\tau'} V_{\sigma\tau\sigma'\tau'}(\mathbf{k}, \mathbf{k}') \langle c_{-\mathbf{k}',\tau'} c_{\mathbf{k}'\sigma'} \rangle \quad (12.39)$$

so that

$$\Delta_{\sigma\tau}^*(\mathbf{k}) = -\frac{1}{N} \sum_{\mathbf{k}'} \sum_{\sigma'\tau'} V_{\sigma'\tau'\sigma\tau}(\mathbf{k}', \mathbf{k}) \langle c_{\mathbf{k}'\sigma'}^{\dagger} c_{-\mathbf{k}',\tau'}^{\dagger} \rangle. \quad (12.40)$$

Here, we have used that

$$[V_{\sigma\tau\sigma'\tau'}(\mathbf{k}, \mathbf{k}')]^* = V_{\sigma'\tau'\sigma\tau}(\mathbf{k}', \mathbf{k}), \quad (12.41)$$

which follows from hermiticity of the Hamiltonian H . Then

$$H_{\text{MF}} = \sum_{\mathbf{k}\sigma} \xi_{\mathbf{k}} c_{\mathbf{k}\sigma}^{\dagger} c_{\mathbf{k}\sigma} - \sum_{\mathbf{k}\sigma\tau} \Delta_{\sigma\tau}^*(\mathbf{k}) c_{-\mathbf{k},\tau} c_{\mathbf{k}\sigma} - \sum_{\mathbf{k}\sigma\tau} \Delta_{\sigma\tau}(\mathbf{k}) c_{\mathbf{k}\sigma}^{\dagger} c_{-\mathbf{k},\tau}^{\dagger} + \text{const.} \quad (12.42)$$

The gap functions $\Delta_{\sigma\tau}(\mathbf{k})$ now form a matrix in spin space,

$$\hat{\Delta}(\mathbf{k}) = \begin{pmatrix} \Delta_{\uparrow\uparrow}(\mathbf{k}) & \Delta_{\uparrow\downarrow}(\mathbf{k}) \\ \Delta_{\downarrow\uparrow}(\mathbf{k}) & \Delta_{\downarrow\downarrow}(\mathbf{k}) \end{pmatrix}. \quad (12.43)$$

The function $\hat{\Delta}(\mathbf{k})$ has an important symmetry property that follows from the symmetry of averages $\langle c_{-\mathbf{k},\tau} c_{\mathbf{k}\sigma} \rangle$: It is clear that

$$\langle c_{\mathbf{k}\sigma} c_{-\mathbf{k},\tau} \rangle = -\langle c_{-\mathbf{k},\tau} c_{\mathbf{k}\sigma} \rangle. \quad (12.44)$$

Furthermore, by relabeling $\sigma \leftrightarrow \tau, \sigma' \leftrightarrow \tau', \mathbf{k} \rightarrow -\mathbf{k}, \mathbf{k}' \rightarrow -\mathbf{k}'$ in the interaction term of H , we see that the interaction strength must satisfy the relation

$$V_{\sigma\tau\sigma'\tau'}(\mathbf{k}, \mathbf{k}') = V_{\tau\sigma\tau'\sigma'}(-\mathbf{k}, -\mathbf{k}'). \quad (12.45)$$

Thus

$$\Delta_{\tau\sigma}(-\mathbf{k}) = -\frac{1}{N} \sum_{\mathbf{k}'} \sum_{\sigma'\tau'} V_{\tau\sigma\tau'\sigma'}(-\mathbf{k}, -\mathbf{k}') \langle c_{\mathbf{k}'\sigma'} c_{-\mathbf{k}'\tau'} \rangle = +\frac{1}{N} \sum_{\mathbf{k}'} \sum_{\sigma'\tau'} V_{\sigma\tau\sigma'\tau'}(\mathbf{k}, \mathbf{k}') \langle c_{-\mathbf{k}'\tau'} c_{\mathbf{k}'\sigma'} \rangle = -\Delta_{\sigma\tau}(\mathbf{k}) \quad (12.46)$$

or, equivalently,

$$\hat{\Delta}(-\mathbf{k}) = -\hat{\Delta}^T(\mathbf{k}), \quad (12.47)$$

where the superscript T denotes the matrix transposition. We now want to write $\hat{\Delta}(\mathbf{k})$ in terms of singlet and triplet components. From elementary quantum theory, a spin-singlet pair is created by

$$s_{\mathbf{k}}^{\dagger} := \frac{c_{\mathbf{k}\uparrow}^{\dagger} c_{-\mathbf{k}\downarrow}^{\dagger} - c_{\mathbf{k}\downarrow}^{\dagger} c_{-\mathbf{k}\uparrow}^{\dagger}}{\sqrt{2}}, \quad (12.48)$$

while the $m = 1, 0, -1$ components of a spin-triplet pair are created by

$$t_{\mathbf{k}1}^{\dagger} := c_{\mathbf{k}\uparrow}^{\dagger} c_{-\mathbf{k}\uparrow}^{\dagger}, \quad (12.49)$$

$$t_{\mathbf{k}0}^{\dagger} := \frac{c_{\mathbf{k}\uparrow}^{\dagger} c_{-\mathbf{k}\downarrow}^{\dagger} + c_{\mathbf{k}\downarrow}^{\dagger} c_{-\mathbf{k}\uparrow}^{\dagger}}{\sqrt{2}}, \quad (12.50)$$

$$t_{\mathbf{k},-1}^{\dagger} := c_{\mathbf{k}\downarrow}^{\dagger} c_{-\mathbf{k}\downarrow}^{\dagger}, \quad (12.51)$$

respectively. Alternatively, we can transform onto states aligned with the x , y , and z axes. This is analogous to the mapping from $(l = 1, m)$ eigenstates onto p_x , p_y , and p_z orbitals for the hydrogen atom. The new components are created by

$$t_{\mathbf{k}x}^{\dagger} := \frac{-c_{\mathbf{k}\uparrow}^{\dagger} c_{-\mathbf{k}\uparrow}^{\dagger} + c_{\mathbf{k}\downarrow}^{\dagger} c_{-\mathbf{k}\downarrow}^{\dagger}}{\sqrt{2}}, \quad (12.52)$$

$$t_{\mathbf{k}y}^{\dagger} := i \frac{c_{\mathbf{k}\uparrow}^{\dagger} c_{-\mathbf{k}\uparrow}^{\dagger} + c_{\mathbf{k}\downarrow}^{\dagger} c_{-\mathbf{k}\downarrow}^{\dagger}}{\sqrt{2}}, \quad (12.53)$$

$$t_{\mathbf{k}z}^{\dagger} := \frac{c_{\mathbf{k}\uparrow}^{\dagger} c_{-\mathbf{k}\downarrow}^{\dagger} + c_{\mathbf{k}\downarrow}^{\dagger} c_{-\mathbf{k}\uparrow}^{\dagger}}{\sqrt{2}} = t_{\mathbf{k}0}^{\dagger}, \quad (12.54)$$

which form a vector $\mathbf{t}_{\mathbf{k}}^{\dagger}$. The term in H_{MF} involving $\Delta_{\sigma\tau}(\mathbf{k})$ can now be expressed in terms of the new operators,

$$\begin{aligned} -\sum_{\mathbf{k}\sigma\tau} \Delta_{\sigma\tau}(\mathbf{k}) c_{\mathbf{k}\sigma}^{\dagger} c_{-\mathbf{k}\tau}^{\dagger} &= -\sum_{\mathbf{k}} \left[\Delta_{\uparrow\uparrow}(\mathbf{k}) \frac{-t_{\mathbf{k}x}^{\dagger} - it_{\mathbf{k}y}^{\dagger}}{\sqrt{2}} + \Delta_{\uparrow\downarrow}(\mathbf{k}) \frac{s_{\mathbf{k}}^{\dagger} + t_{\mathbf{k}z}^{\dagger}}{\sqrt{2}} + \Delta_{\downarrow\uparrow}(\mathbf{k}) \frac{-s_{\mathbf{k}}^{\dagger} + t_{\mathbf{k}z}^{\dagger}}{\sqrt{2}} + \Delta_{\downarrow\downarrow}(\mathbf{k}) \frac{t_{\mathbf{k}x}^{\dagger} - it_{\mathbf{k}y}^{\dagger}}{\sqrt{2}} \right] \\ &\stackrel{!}{=} -\sum_{\mathbf{k}} \sqrt{2} \left[\Delta_{\mathbf{k}} s_{\mathbf{k}}^{\dagger} + \mathbf{d}(\mathbf{k}) \cdot \mathbf{t}_{\mathbf{k}}^{\dagger} \right] \end{aligned} \quad (12.55)$$

(the factor $\sqrt{2}$ is conventional), which requires

$$\Delta_{\mathbf{k}} = \frac{\Delta_{\uparrow\downarrow}(\mathbf{k}) - \Delta_{\downarrow\uparrow}(\mathbf{k})}{2}, \quad (12.56)$$

$$d_x(\mathbf{k}) = \frac{-\Delta_{\uparrow\uparrow}(\mathbf{k}) + \Delta_{\downarrow\downarrow}(\mathbf{k})}{2}, \quad (12.57)$$

$$d_y(\mathbf{k}) = -i \frac{\Delta_{\uparrow\uparrow}(\mathbf{k}) + \Delta_{\downarrow\downarrow}(\mathbf{k})}{2}, \quad (12.58)$$

$$d_z(\mathbf{k}) = \frac{\Delta_{\uparrow\downarrow}(\mathbf{k}) + \Delta_{\downarrow\uparrow}(\mathbf{k})}{2}. \quad (12.59)$$

The term in H_{MF} involving $\Delta_{\sigma\tau}^*(\mathbf{k})$ is just the hermitian conjugate of the one considered. We have now identified the singlet component of the gap, $\Delta_{\mathbf{k}}$, and the triplet components, $\mathbf{d}(\mathbf{k})$. Since

$$\hat{\Delta}(\mathbf{k}) = \begin{pmatrix} -d_x(\mathbf{k}) + id_y(\mathbf{k}) & \Delta_{\mathbf{k}} + d_z(\mathbf{k}) \\ -\Delta_{\mathbf{k}} + d_z(\mathbf{k}) & d_x(\mathbf{k}) + id_y(\mathbf{k}) \end{pmatrix}, \quad (12.60)$$

we can write the gap matrix in a compact form as

$$\hat{\Delta}(\mathbf{k}) = (\Delta_{\mathbf{k}}\mathbb{1} + \mathbf{d}(\mathbf{k}) \cdot \boldsymbol{\sigma}) i\sigma^y, \quad (12.61)$$

where $\boldsymbol{\sigma}$ is the vector of Pauli matrices. The appearance of the factor

$$i\sigma^y = \begin{pmatrix} 0 & 1 \\ -1 & 0 \end{pmatrix} \quad (12.62)$$

should not be misinterpreted as showing that the y -component of the Cooper-pair spin is in some way singled out. Rather, the factor stems from the anticommutativity of fermionic operators and is only expressed in terms of the Pauli matrix σ^y for convenience. It can also be understood as the unitary part of the antiunitary time-reversal operator.

The mean-field Hamiltonian H_{MF} is diagonalized by a Bogoliubov transformation and the gap function $\hat{\Delta}(\mathbf{k})$ is obtained selfconsistently from a gap equation in complete analogy to the singlet case discussed in Sec. 10.1, except that $\hat{\Delta}(\mathbf{k})$ is now a matrix and that we require four coefficients $u_{\mathbf{k}\uparrow}$, $u_{\mathbf{k}\downarrow}$, $v_{\mathbf{k}\uparrow}$, $v_{\mathbf{k}\downarrow}$. We do not show this here explicitly.

A few remarks on the physics are in order, though. The symmetry $\hat{\Delta}(-\mathbf{k}) = -\hat{\Delta}^T(\mathbf{k})$ implies

$$\begin{aligned} (\Delta_{-\mathbf{k}}\mathbb{1} + \mathbf{d}(-\mathbf{k}) \cdot \boldsymbol{\sigma}) i\sigma^y &= \underbrace{-i(\sigma^y)^T}_{i\sigma^y} (\Delta_{\mathbf{k}}\mathbb{1} + \mathbf{d}(\mathbf{k}) \cdot \boldsymbol{\sigma}^T) \\ \Rightarrow \quad \Delta_{-\mathbf{k}}\mathbb{1} + \mathbf{d}(-\mathbf{k}) \cdot \boldsymbol{\sigma} &= \sigma^y (\Delta_{\mathbf{k}}\mathbb{1} + \mathbf{d}(\mathbf{k}) \cdot \boldsymbol{\sigma}^T) \sigma^y \\ &= \Delta_{\mathbf{k}}\mathbb{1} + \mathbf{d}(\mathbf{k}) \cdot \begin{pmatrix} \sigma^y (\sigma^x)^T \sigma^y \\ \sigma^y (\sigma^y)^T \sigma^y \\ \sigma^y (\sigma^z)^T \sigma^y \end{pmatrix} \\ &= \Delta_{\mathbf{k}}\mathbb{1} + \mathbf{d}(\mathbf{k}) \cdot \begin{pmatrix} \sigma^y \sigma^x \sigma^y \\ -\sigma^y \sigma^y \sigma^y \\ \sigma^y \sigma^z \sigma^y \end{pmatrix} \\ &= \Delta_{\mathbf{k}}\mathbb{1} - \mathbf{d}(\mathbf{k}) \cdot \boldsymbol{\sigma}. \end{aligned} \quad (12.64)$$

Thus we conclude that $\Delta_{\mathbf{k}}$ is even,

$$\Delta_{-\mathbf{k}} = \Delta_{\mathbf{k}}, \quad (12.65)$$

whereas $\mathbf{d}(\mathbf{k})$ is odd,

$$\mathbf{d}(-\mathbf{k}) = -\mathbf{d}(\mathbf{k}). \quad (12.66)$$

Hence, the d -vector can never be constant, unlike the singlet gap in Sec. 10.1. Furthermore, we can expand $\Delta_{\mathbf{k}}$ into even basis functions of irreducible representations of the point group of the system (which contains rotations, inversion, and mirror reflections that leave the crystal structure invariant), e.g.,

$$\Delta_{\mathbf{k}} = \Delta_s \psi_s(\mathbf{k}) + \Delta_{d_{x^2-y^2}} \psi_{d_{x^2-y^2}}(\mathbf{k}) + \Delta_{d_{3z^2-r^2}} \psi_{d_{3z^2-r^2}}(\mathbf{k}) + \Delta_{d_{xy}} \psi_{d_{xy}}(\mathbf{k}) + \Delta_{d_{yz}} \psi_{d_{yz}}(\mathbf{k}) + \Delta_{d_{zx}} \psi_{d_{zx}}(\mathbf{k}) + \dots, \quad (12.67)$$

and expand (the components of) $\mathbf{d}(\mathbf{k})$ into odd basis functions,

$$\mathbf{d}(\mathbf{k}) = \mathbf{d}_{p_x} \psi_{p_x}(\mathbf{k}) + \mathbf{d}_{p_y} \psi_{p_y}(\mathbf{k}) + \mathbf{d}_{p_z} \psi_{p_z}(\mathbf{k}) + \dots \quad (12.68)$$

For the singlet case, we have already considered the basis functions $\psi_s(\mathbf{k}) = 1$ for conventional superconductors, $\psi_s(\mathbf{k}) = \cos k_x a \cos k_y a$ for the pnictides, and $\psi_{d_{x^2-y^2}}(\mathbf{k}) = \cos k_x a - \cos k_y a$ for the cuprates. Typical basis functions for a triplet superconductor would be $\psi_{p_i} = \sin k_i a$, $i = x, y, z$. He-3 in the so-called B phase realized at not too high pressures and temperatures (see the phase diagram in Sec. 2.2) has the d -vector

$$\mathbf{d}(\mathbf{k}) = \Delta_1 [\hat{\mathbf{x}} \psi_{p_x}(\mathbf{k}) + \hat{\mathbf{y}} \psi_{p_y}(\mathbf{k}) + \hat{\mathbf{z}} \psi_{p_z}(\mathbf{k})], \quad (12.69)$$

where the basis functions are that standard expressions for p_x , p_y , and p_z orbitals (note that there is no Brillouin zone since He-3 is a liquid),

$$\psi_{p_x}(\mathbf{k}) = \sqrt{\frac{3}{4\pi}} \sin \theta_{\mathbf{k}} \cos \phi_{\mathbf{k}}, \quad (12.70)$$

$$\psi_{p_y}(\mathbf{k}) = \sqrt{\frac{3}{4\pi}} \sin \theta_{\mathbf{k}} \sin \phi_{\mathbf{k}}, \quad (12.71)$$

$$\psi_{p_z}(\mathbf{k}) = \sqrt{\frac{3}{4\pi}} \cos \theta_{\mathbf{k}} \quad (12.72)$$

so that

$$\mathbf{d}(\mathbf{k}) = \sqrt{\frac{3}{4\pi}} \Delta_1 \hat{\mathbf{k}}. \quad (12.73)$$

Hence, He-3 shows *p-wave* spin-triplet pairing. This is the so-called *Balian-Werthamer state*. Note that it has the property that

$$|\mathbf{d}(\mathbf{k})| = \sqrt{\frac{3}{4\pi}} |\Delta_1| = \text{const} \quad (12.74)$$

so that $\hat{\Delta}(\mathbf{k})$ is nonzero everywhere. What is important here is that the superconducting gap is nonzero everywhere on the normal-state Fermi surface. The Balian-Werthamer state does not have nodes.

The A phase covers a smaller part of the phase diagram. Here, the \mathbf{d} -vector reads

$$\mathbf{d}(\mathbf{k}) = \Delta_1 \hat{\mathbf{d}} [\psi_{p_x}(\mathbf{k}) + i\psi_{p_y}(\mathbf{k})], \quad (12.75)$$

where $\hat{\mathbf{d}}$ is a fixed unit vector. By symmetry, all states obtained by rotating $\hat{\mathbf{d}}$ or the “orbitals” p_x and p_y are degenerate. This is called the *Anderson-Brinkman-Morel state*. Unlike the Balian-Werthamer state, it has point nodes. For the \mathbf{d} vector above, these appear at $k_x = k_y = 0$ since then $\psi_{p_x}(\mathbf{k}) = \psi_{p_y}(\mathbf{k}) = 0$.

There are not many pure spin-triplet superconductors as opposed to the superfluid He-3. Triplet pairing is favored for the superconductor UPt₃. As discussed above, fermionic anticommutation implies that the order parameter must have the form

$$\hat{\Delta}(\mathbf{k}) = \mathbf{d}(\mathbf{k}) \cdot \boldsymbol{\sigma} i\sigma^y \quad (12.76)$$

with an odd function $\mathbf{d}(\mathbf{k})$. The correct way to classify pairing states uses irreducible representations of the point group of the crystal. We will not explain this type of analysis but only note that the favored \mathbf{d} -vectors belong to the irreducible representation E_{2u} of the point group D_{6h} of UPt₃ [see R. Joynt and L. Taillefer, *Rev. Mod. Phys.* **74**, 235 (2002)]. They are thought to be linear combinations of two basis vectors $\mathbf{d}_1(\mathbf{k})$ and $\mathbf{d}_2(\mathbf{k})$, which under point-group operations transform like

$$\mathbf{d}_1(\mathbf{k}) = (k_x^2 - k_y^2)k_z \hat{\mathbf{z}}, \quad (12.77)$$

$$\mathbf{d}_2(\mathbf{k}) = k_x k_y k_z \hat{\mathbf{z}}. \quad (12.78)$$

These basis functions are of third order in momentum, meaning that they describe a form of *f-wave* pairing. It should be noted that $\mathbf{d}_1(\mathbf{k})$ and $\mathbf{d}_2(\mathbf{k})$ cannot be correct *d*-vectors for all momenta since they violate the periodicity of momentum space. It is, however, common practice to write down basis functions obtained by group-theoretical analysis in terms of lowest-order polynomials.

12.5 Noncentrosymmetric superconductors

In crystals lacking inversion symmetry, i.e., *noncentrosymmetric* crystals, a term of the form

$$H_{\text{ASOC}} = \lambda \sum_{\mathbf{k}} c_{\mathbf{k}}^\dagger \mathbf{g}(\mathbf{k}) \cdot \boldsymbol{\sigma} c_{\mathbf{k}}, \quad (12.79)$$

with the spinor operator

$$c_{\mathbf{k}} = \begin{pmatrix} c_{\mathbf{k}\uparrow} \\ c_{\mathbf{k}\downarrow} \end{pmatrix} \quad (12.80)$$

and an odd function $\mathbf{g}(\mathbf{k})$ is allowed by symmetry. This term represents *antisymmetric spin-orbit coupling* (ASOC). It is forbidden in the presence of inversion symmetry since under inversion $\mathbf{g}(\mathbf{k})$ (being odd in \mathbf{k})

changes sign but the spin $\boldsymbol{\sigma}$ (being a pseudovector) does not. The ASOC splits the bands for the normal state, except at high-symmetry points with $\mathbf{g}(\mathbf{k}) = 0$.

Due to the ASOC, spin is not conserved. This means that also the spin of a Cooper pair is not a good quantum number. We can still write the pairing matrix as

$$\hat{\Delta}(\mathbf{k}) = (\Delta_{\mathbf{k}}\mathbb{1} + \mathbf{d}(\mathbf{k}) \cdot \boldsymbol{\sigma}) i\sigma^y \quad (12.81)$$

with even $\Delta_{\mathbf{k}}$ and odd $\mathbf{d}(\mathbf{k})$ since this is the most general 2×2 matrix satisfying the condition $\hat{\Delta}(-\mathbf{k}) = -\hat{\Delta}^T(\mathbf{k})$ imposed by fermionic anticommutation. But since the spin is not conserved, generically both the singlet amplitude $\Delta_{\mathbf{k}}$ and the triplet amplitudes $d_x(\mathbf{k})$, $d_y(\mathbf{k})$, $d_z(\mathbf{k})$ are nonzero. In other words, noncentrosymmetric crystals show a superposition of singlet and triplet pairs, called *singlet-triplet mixing*. It was shown by Frigeri *et al.* [Phys. Rev. Lett. **92**, 097001 (2004)] that pairing states with $\mathbf{d}(\mathbf{k}) \parallel \mathbf{g}(\mathbf{k})$ are energetically favorable. This is plausible since the Cooper pairs are then “compatible” with the ASOC in the normal-state Hamiltonian. Examples for noncentrosymmetric superconductors are YPtBi, CePt₃Si, CeRhSi₃, and Y₂C₃.

As an example, let us consider a cubic crystal with point group T_d , which does not include inversion symmetry. Then, the lowest-order polynomial form for the g -vector reads

$$\mathbf{g}(\mathbf{k}) = k_x(k_y^2 - k_z^2)\hat{\mathbf{x}} + k_y(k_z^2 - k_x^2)\hat{\mathbf{y}} + k_z(k_x^2 - k_y^2)\hat{\mathbf{z}}. \quad (12.82)$$

The d -vector should be parallel to $\mathbf{g}(\mathbf{k})$. On the other hand, the singlet amplitude $\Delta_{\mathbf{k}}$ is not constrained by symmetry, beyond being even. This leads to the simplest ansatz

$$\hat{\Delta}(\mathbf{k}) = (\Delta_s\mathbb{1} + \Delta_t [k_x(k_y^2 - k_z^2)\sigma_x + k_y(k_z^2 - k_x^2)\sigma_y + k_z(k_x^2 - k_y^2)\sigma_z]) i\sigma^y, \quad (12.83)$$

with a singlet amplitude Δ_s and a triplet amplitude Δ_t (with some dimensionfull factors absorbed). The eigenvalues of the factor in large parentheses are

$$\Delta_s \pm \Delta_t \sqrt{[k_x(k_y^2 - k_z^2)]^2 + [k_y(k_z^2 - k_x^2)]^2 + [k_z(k_x^2 - k_y^2)]^2}. \quad (12.84)$$

Evidently, one of the eigenvalues crosses zero if $|\Delta_t/\Delta_s|$ is sufficiently large. This happens on a surface in momentum space since there is one constraint on (k_x, k_y, k_z) . This surface generically intersects with the normal-state Fermi surface along a line. Hence, we expect line nodes if the triplet component is sufficiently large. Recall that for the cuprates the line nodes occur in the high-symmetry (mirror) planes $k_y = \pm k_x$. Here, the situation is very different: the vanishing eigenvalue and thus the line nodes are not tight to high-symmetry planes.