

QUANTUM TECH NEWS



Credit: University of Nottingham© Provided by Phys.org

The full, weird story of the quantum world is much too large for a single article, but the period from 1905, when Einstein first published his solution to the photoelectric puzzle, to the 1960's, when a complete, well-tested, rigorous, and insanely complicated quantum theory of the subatomic world finally emerged, is quite the story.

This quantum theory would come to provide, in its own way, its own complete and total revision of our understanding of light. In the quantum picture of the subatomic world, what we call the electromagnetic force is really the product of countless microscopic interactions, the work of indivisible photons, who interact in mysterious ways. As in, literally mysterious. The quantum framework provides no picture as to how subatomic interactions actually proceed. Rather, it merely gives us a mathematical toolset for calculating predictions. And so while we can only answer the question of how photons actually work with a beleaguered

shrug, we are at least equipped with some predictive power, which helps assuage the pain of quantum incomprehensibility.

Doing the business of physics—that is, using mathematical models to make predictions to validate against experiment—is rather hard in quantum mechanics. And that's because of the simple fact that quantum rules are not normal rules, and that in the subatomic realm all bets are off.

Interactions and processes at the subatomic level are not ruled by the predictability and reliability of macroscopic processes. In the macroscopic world, everything makes sense (largely because we've evolved to make sense of the world we live in). I can toss a ball enough times to a child that their brain can quickly pick up on the reliable pattern: the ball leaves my hand, the ball follows an arcing path, the ball moves forward and eventually falls to the ground. Sure, there are variations based on speed and angle and wind, but the basic gist of a tossed ball is the same, every single time.

Not so in the quantum world, where perfect prediction is impossible and reliable statements are lacking. At subatomic scales, probabilities rule the day—it's impossible to say exactly what any given particle will do at any given moment. And this absence of predictability and reliability at first troubled and then disgusted Einstein, who would eventually leave the quantum world behind with nothing more than a regretful shake of his head at the misguided work of his colleagues. And so he continued his labors, attempting to find a unified approach to joining the two known forces of nature, electromagnetism and gravity, with an emphatically not quantum framework.

When two new forces were first proposed in the 1930's to explain the deep workings of atomic nuclei—the strong and weak nuclear forces, respectively—this did not deter Einstein. Once electromagnetism and gravity were successfully united, it would not take much additional effort to work in new forces of nature. Meanwhile, his quantum-leaning contemporaries took to the new forces with gusto, eventually folding them into the quantum worldview and framework.

By the end of Einstein's life, quantum mechanics could describe three forces of nature, while gravity stood alone, his general theory of relativity a monument to his intellect and creativity.

Provided by Universe Today

This story was originally published on [Phys.org](https://www.phys.org).

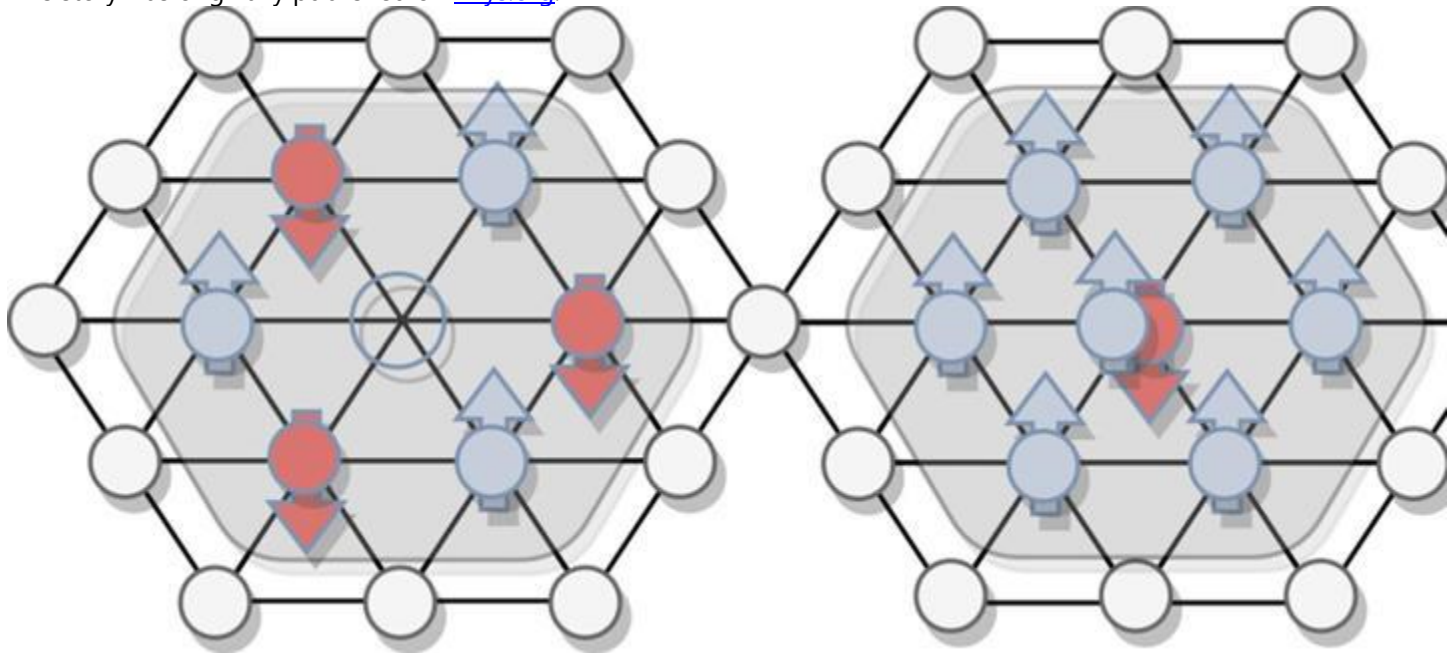

In kinetic magnetism, an extra electron paired up to form a doublon can lead to ferromagnetic order of the spins in its vicinity (right), whereas a missing electron or hole causes antiferromagnetic order (left). Credit: Morera, I. et al. High-temperature kinetic magnetism in triangular lattices. Phys. Rev. Res. 5, L022048 2023)© Provided by Phys.org

By analyzing images made of colored dots created by quantum simulators,

ETH researchers have studied a special kind of magnetism. In the future this method could also be used to solve other physics puzzles, for instance in superconductivity.

Up close it looks like lots of colored dots, but from a distance one sees a complex picture rich in detail: Using the technique of pointillism, in 1886 George Seurat created the masterpiece "A Sunday afternoon on the island of La Grande Jatte." In a similar way, Eugene Demler and his coworkers at ETH Zurich study complex quantum systems made of many interacting particles. In their case, the dots are not created by dabbing a paintbrush, but rather by making individual atoms visible in the laboratory.

Individual spin components

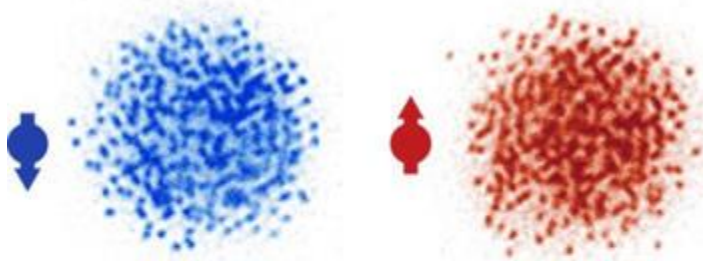

Fully reconstructed image

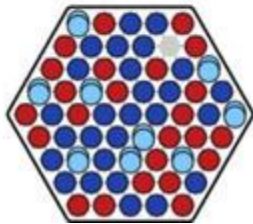

Similarly to George Seurat's pointillism ("A Sunday afternoon on the island of La Grande Jatte", right), in quantum pointillism complex pictures are created from colored points (left). From these pictures, the researchers can draw conclusions about the processes in the quantum system using theoretical calculations. Credit: Left : Prichard et al., 2024; Right: Keystone-SDA)© Provided by Phys.org

Together with colleagues in Harvard and Princeton, Demler's group has now used the new method—which they call "quantum pointillism"—to take a closer look at a special kind of magnetism.

The researchers have just published their results in two papers in the journal *Nature* with titles "[Observation of Nagaoka polarons in a Fermi–Hubbard quantum simulator](#)" and "[Directly imaging spin polarons in a kinetically frustrated Hubbard system](#)."

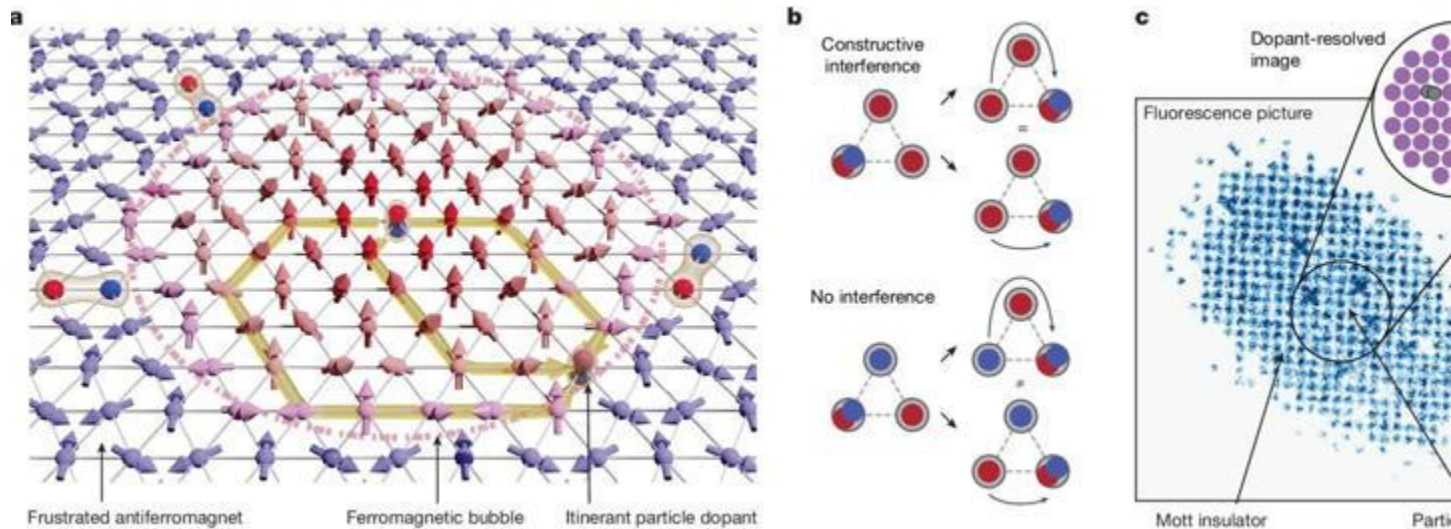

Paradigm shift in understanding

"These studies represent a paradigm shift in our understanding of such magnetic quantum phenomena. Until now, we were not able to study them in detail," says Demler. It all started around two years ago at ETH. The group of Ataç Imamoğlu experimentally investigated special materials with a triangular crystal lattice (moiré materials made of transition metal dichalcogenides).

When Demler and his postdoc Ivan Morera analyzed Imamoğlu's data, they encountered a peculiarity that suggested a kind of magnetism that had previously only been predicted theoretically.

"In this kinetic magnetism, a few electrons moving inside the crystal lattice can magnetize the material," Morera explains.

In Imamoğlu's experiment this effect, known as Nagaoka mechanism among experts, could be detected for the first time in a solid by measuring, among other things, the magnetic susceptibility—that is, how strongly the material reacts to an external magnetic field.

"That detection was based on very strong evidence. For a direct proof, however, one would have to measure the state of the electrons—their position and spin direction—simultaneously in several places inside the material," says Demler.

Complex processes made visible

In a solid, however, this is not possible with conventional methods. At most, researchers can use X-ray or neutron diffraction to find out how the spins of the electrons relate to each other at two positions—the so-called spin correlation. Correlations between complex spin arrangements and additional or missing electrons cannot be measured in this way.

To still make the complex processes of the Nagaoka mechanism visible, which Demler and Morera had calculated using a model, they turned to colleagues in Harvard and Princeton. There, research teams led by Markus Greiner and Waseem Bakr have developed quantum simulators that can be used to precisely recreate the conditions inside a solid.

Instead of electrons moving inside a lattice made of atoms, in such simulators the U.S. researchers use extremely cold atoms trapped inside an optical lattice made of light beams. The mathematical equations describing the electrons inside the solid and the atoms inside the optical lattice, however, are almost identical.

Colored snapshots of the quantum system

Using a strongly magnifying microscope, Greiner's and Bakr's groups were able not only to resolve the positions of the individual atoms, but also their spin directions. They translated the information obtained from these snapshots of the quantum system into colored graphics that could be compared to the theoretical pointillist pictures.

Demler and his coworkers had theoretically calculated, for instance, how a single extra electron in the Nagaoka mechanism forms a pair with another electron of opposite spin and then moves through the triangular lattice of the material as a doublon.

According to the prediction of Demler and Morera, that doublon should be surrounded by a cloud of electrons whose spin directions are parallel, or ferromagnetic. Such a cloud is also known as a magnetic polaron.

That is exactly what the American researchers saw in their experiments. Moreover, if there was an atom missing in the crystal optical lattice of the quantum simulator—which corresponds to a missing electron or "hole" in the real crystal—then the cloud forming around that hole consisted of pairs of atoms whose spins pointed in opposite directions, just as Demler and Morera had predicted.

This antiferromagnetic order (or, more precisely: antiferromagnetic correlations) had also previously been indirectly detected in a solid state experiment at Cornell University in the U.S. In the quantum simulator, it now became directly visible.

"For the first time, we have solved a physics puzzle using experiments both on the 'real' solid as well as in the quantum simulator. Our theoretical work is the glue that holds everything together," says Demler. He is confident that in the future his method will also be useful for solving other tricky problems.

For instance, the mechanism that causes the magnetic polaron cloud to form could also play an important role in high temperature superconductors.

More information: Martin Lebrat et al, Observation of Nagaoka polarons in a Fermi–Hubbard quantum simulator, *Nature* (2024). [DOI: 10.1038/s41586-024-07272-9](https://doi.org/10.1038/s41586-024-07272-9)

Max L. Prichard et al, Directly imaging spin polarons in a kinetically frustrated Hubbard system, *Nature* (2024). [DOI: 10.1038/s41586-024-07356-6](https://doi.org/10.1038/s41586-024-07356-6)

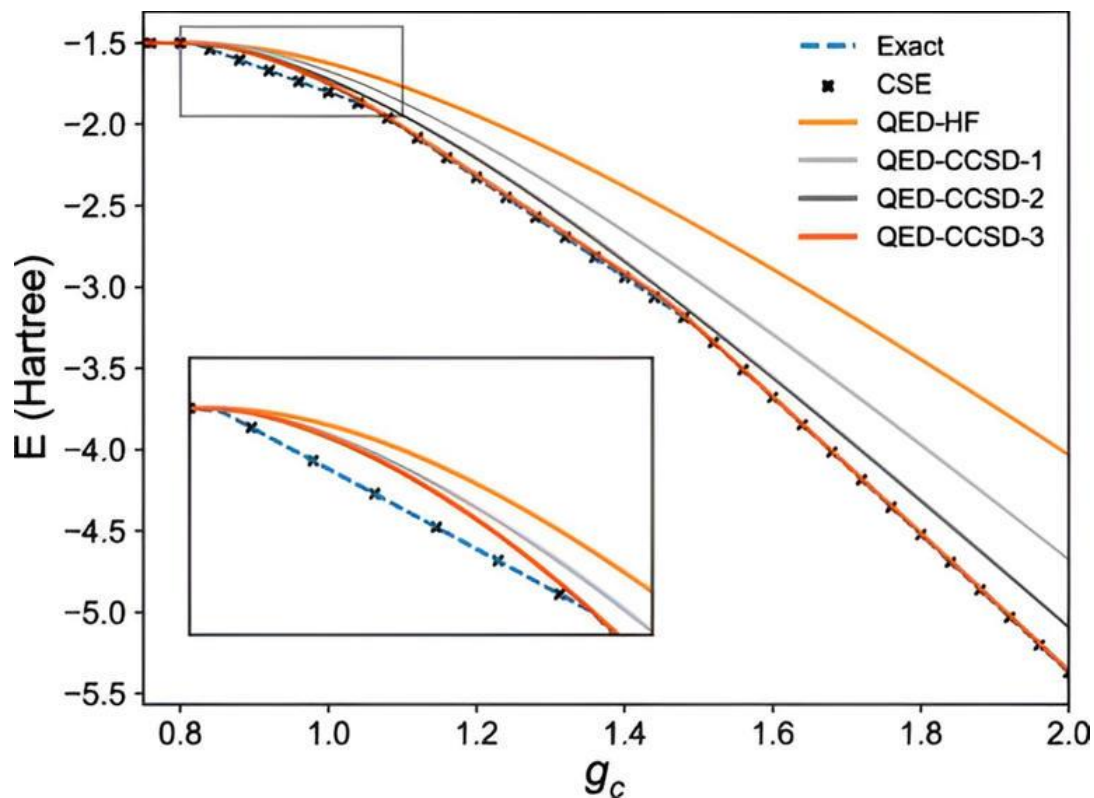

CSE and QED-CCSD energies for the three fermion Tavis-Cummings model with increasing coupling. The Hamiltonian parameters from Eq. (14) were fixed as $(\omega_b, \omega_f) = (2, 0.5)$, while g_c is varied as shown along the x axis. The QED-CCSD- n methods are named according to the convention used in Ref. [41]. Credit: Physical Review Letters (2024). DOI: 10.1103/PhysRevLett.133.080202

A study coordinated by the University of Trento with the University of

Chicago proposes a generalized approach to the interactions between electrons and light. In the future, it may contribute to the development of quantum technologies as well as to the discovery of new states of matter. The study is [published](#) in *Physical Review Letters*

Understanding the interaction between quantum particles is crucial in the discovery of new molecules or materials that can be used for novel technological or medical applications. For instance, when molecules or chemical compounds interact with light, their physical properties can change substantially.

Bearing this in mind, the new field of polaritonic chemistry aims to trigger new chemical reactions using light as a catalyst. More generally, controlling light-matter interactions provides a way to manipulate and synthesize new quantum matter.

The research work, as always, progresses by making hypotheses that must be verified. But when the object of study is a quantum system involving a multitude of different elements, i.e. electrons, photons, phonons, the situation can be even more complicated. It is difficult to accurately calculate the wave function of such a system, that is, a function that contains the relevant physical information to make accurate predictions about the behavior of many quantum particles of more than one type.

A group of researchers from the University of Chicago, coordinated by Carlos Leonardo Benavides-Riveros, a research fellow at the Department of Physics of the University of Trento, and David A. Mazziotti from the University of Chicago, made a contribution to this topic.

They started with an "ansatz," a theoretical prescription, that can help them predict the interactions among the particles in a many-body quantum system on a quantum computer. Then they generalized this ansatz to treat systems that contain more than one type of quantum particle, e.g., systems that contain not only electrons but also photons and/or phonons.

To demonstrate, the researchers have simulated a universal quantum algorithm on an IBM quantum computer, with zero theoretical error.

And that is the novelty of this study: the researchers have developed a single approach that can be used to generate exponential prescriptions (ansatzes) for many-body quantum systems with more than one type of particle that, when implemented on quantum devices, produces exact wave functions.

According to physicists, this solution also opens up new perspectives in the study of the states of matter.

"Quantum systems as molecules or solids, as we find them in nature, never contain only electrons. Many fascinating properties can be created or suppressed when light interacts with them," explains Benavides-Riveros.

"What we did," he continues, "was to introduce other quantum particles beyond electrons such as particles of light, commonly known as photons. And by following our universal formulation of the problem we can understand the structure of its wave function and hence, its physical properties."

"Because the ansatz is particularly suitable for quantum computers, the advance opens new possibilities for using quantum computers to model important molecular problems in light-matter interaction, such as occur in polaritonic chemistry," Mazziotti says.

More information: Samuel Warren et al, Exact Ansatz of Fermion-Boson Systems for a Quantum Device, *Physical Review Letters* (2024). [DOI: 10.1103/PhysRevLett.133.080202](https://doi.org/10.1103/PhysRevLett.133.080202). On *arXiv*: [DOI: 10.48550/arxiv.2402.12273](https://doi.org/10.48550/arxiv.2402.12273)

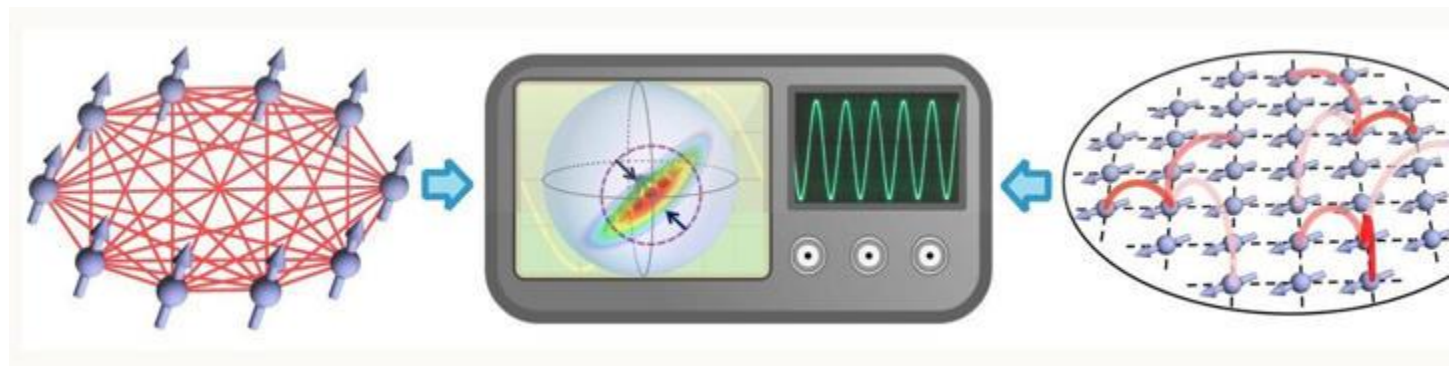

Spin squeezing is a form of quantum entanglement that can enable more precise measurements (middle). Previously known to arise only in all-to-all interacting systems (left), Harvard researchers have shown that spin squeezing can occur more generally in locally interacting systems that form planar magnets (right). Credit: Bingtian Ye

Nothing in science can be achieved or understood without measurement.

Today, thanks to advances in quantum sensing, scientists can measure things that were once impossible to even imagine: vibrations of atoms, properties of individual photons, fluctuations associated with gravitational waves.

A quantum mechanical trick called "spin squeezing" is widely recognized to hold promise for supercharging the capabilities of the world's most precise quantum sensors, but it's been notoriously difficult to achieve. In new research, Harvard physicists describe how they've put spin squeezing within better reach.

A type of quantum entanglement, spin squeezing, constrains the way an ensemble of particles can fluctuate. This enables more precise measurements of certain observable signals, at the expense of measuring other, complementary signals as accurately—think of how squeezing a balloon yields more height at the expense of width.

"Quantum mechanics can enhance our ability to measure very small signals," said Norman Yao, a physics professor and author of the [paper on spin squeezing](#) in *Nature Physics*. "We have shown that it is possible to get such quantum-enhanced metrology in a much broader class of systems than was previously thought."

In the balloon metaphor, a circle represents the uncertainty intrinsic to any quantum measurement, explained Maxwell Block, co-author of the paper and a former Griffin Graduate School of Arts and Sciences student.

"By squeezing this uncertainty, making the balloon more like an ellipse, one can reshape the sensitivity of measurements," Block said. "This means that certain measurements can be more precise than anything one could possibly do without quantum mechanics."

An analog of spin squeezing was used, for example, to [increase the sensitivity](#) of the Nobel-garnering gravitational wave detectors in the LIGO experiment.

The Harvard team's work built upon a landmark [1993 paper](#) that first described the possibility of a spin-squeezed, entangled state brought about by "all-to-all" interactions between atoms. Such interactions are akin to a large Zoom meeting, in which each participant is interacting with every other participant at once.

Between atoms, this type of connectivity easily enables the build-up of the quantum mechanical correlations necessary to induce a spin-squeezed state. However, in nature, atoms typically interact in a way that's more like a game of telephone, only speaking with a few neighbors at a time.

"For years, it has been thought that one can only get truly quantum-enhanced spin squeezing via all-to-all interactions," said Bingtian Ye, co-lead author of the paper and also a former Griffin Graduate School of Arts and Sciences student. "But what we have shown is that it is actually way easier."

In their paper, the researchers outline a new strategy for generating spin-squeezed entanglement. They intuited, and together with collaborators in France quickly [confirmed](#) via experiment that the ingredients for spin squeezing are present in a ubiquitous type of magnetism found often in nature—ferromagnetism, which is also the force that makes refrigerator magnets stick.

They posit that all-to-all interactions are not necessary to achieve spin squeezing, but rather, so long as the spins are connected well enough to sync into a magnetic state, they should also be able to dynamically generate spin squeezing.

The researchers are optimistic that by thus lowering the barrier to spin squeezing, their work will inspire new ways for quantum scientists and engineers to create more portable sensors, useful in biomedical imaging, atomic clocks, and more.

In that spirit, Yao is now leading experiments to generate spin-squeezing in quantum sensors made out of nitrogen-vacancy centers, which are a type of defect in the crystal structure of diamond that have long been recognized as ideal quantum sensors.

More information: Maxwell Block et al, Scalable spin squeezing from finite-temperature easy-plane magnetism, *Nature Physics* (2024). [DOI: 10.1038/s41567-024-02562-5](https://doi.org/10.1038/s41567-024-02562-5)

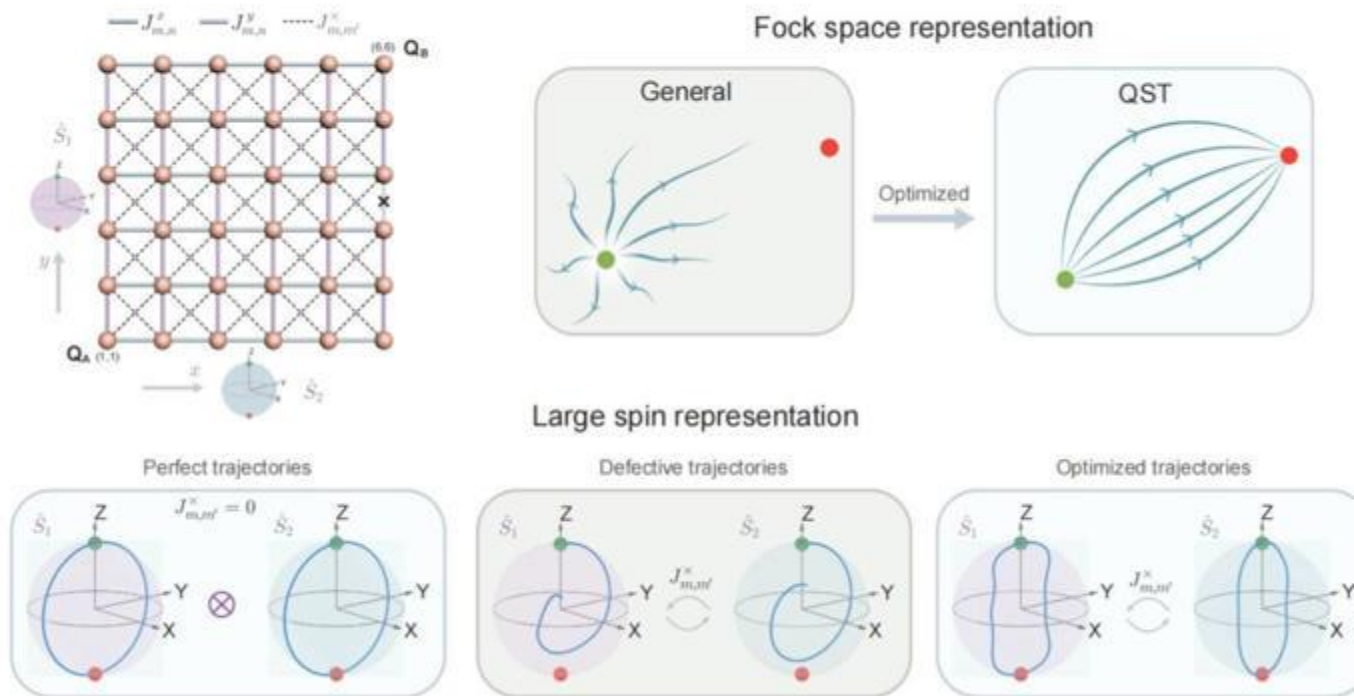

Quantum state transfer (QST) performed in a 6x6 qubit lattice. Credit: Liang Xiang et al. 10.1038/s41467-024-48791-3. © Provided by Phys.org

An international team of scientists from China and the U.S. has developed a scalable protocol for high-fidelity quantum state transfer (QST) in a 36-qubit superconducting quantum circuit.

The researchers focused on optimizing qubit coupling to overcome quantum chaos in 2D quantum networks.

As quantum computing systems grow and focus on using more solid-state architectures, so does the need for high-fidelity, short-range quantum communication. In particular, superconducting qubits are favored as they offer more scalability and practicality in building 2D quantum networks.

The more traditional approaches for QST in 2D networks face challenges with the accumulation of errors. Therefore, the researchers propose an alternate approach focused on optimizing qubit coupling.

Phys.org spoke to some of the researchers behind the [Nature Communications study](#) to understand more about their work.

Co-authors Prof. Qiujiang Guo and Postdoctoral fellow Dr. Liang Xiang from Zhejiang University, China, explained their motivation behind the research: "Technically, short-range communication between different parts of the solid-state quantum system is demanding for both scaling up quantum processors and efficient implementation of quantum algorithms.

"On the other hand, programmable superconducting processors are the natural choice to act as the medium for quantum information transfer. Yet experimental demonstration of quantum state transfer is largely confined to small chains with few qubits," they said.

Understanding QST

"In the quest to build a full-fledged quantum computer, one aims to reproduce the capabilities of its classical counterpart, namely, processing, storage, and communication," said Prof. Richard T. Scalettar from the University of California, Davis, co-author of the study.

"Our research focused on the latter, tackling how to efficiently transport a quantum state between two ends of a quantum device," added Prof. Rubem Mondaini from the University of Houston, also a co-author of the study.

QST is the process of transferring the state of a quantum system from one qubit to another. It is the foundation of all quantum information and communication systems.

When referring to the fidelity of QST, it means how accurately the transfer of information happens without errors or decoherence. One of the main challenges is minimizing errors due to environmental interactions.

Previous research has demonstrated QST for ideal single-particle systems.

"What this original approach fails is to account for the fact that actual quantum devices are far from perfect, and ideal cases without defects or unwanted couplings are unlike what is possibly seen in a real-life quantum device," explained Prof. Mondaini.

Qubit coupling and quantum chaos

For quantum communication, one of the key elements is qubit coupling. This is an interaction between qubits where the state of one qubit influences the state of another. It is typically mediated by electromagnetic fields for superconducting qubits. The extent of this interaction is measured by coupling strength, which can often be tuned or controlled.

While qubit coupling is needed for information transfer between qubits in a system, it also brings up challenges like chaos.

Quantum chaos refers to a state where a quantum system's behavior is unpredictable due to complex interactions within the system. This unpredictability is highly sensitive to the initial state of the system, leading to significant changes in behavior with slight variations in initial conditions.

Chaos is exaggerated in systems with high coupling strength between qubits, causing errors in QST by disrupting coherence. Defects (like irregularities or imperfections), as Prof. Mondaini mentioned, can also exacerbate chaotic behavior.

Therefore, managing chaos in quantum systems is essential for quantum communication.

"Our method works for non-ideal quantum networks, i.e., even if the coupling between the qubits cannot be set at pre-established values needed for a perfect state transfer," said Prof. Scalettar.

Monte Carlo annealing

The team approached the problem using a hybrid method, wherein a classical computer performed the optimization task, and a superconducting quantum circuit used the optimization to carry out QST.

For optimization, the researchers used a method called Monte Carlo (MC) annealing. Annealing is a process used in metallurgy, where a material is heated to a very high temperature and then slowly cooled down to modify the material's properties.

In this case, the researchers want to maximize fidelity (or efficient QST) and optimize the coupling strength parameter. Simply put, they want to find the optimum value of the coupling strength for which we can get efficient QST.

Exploring every possible configuration to optimize coupling strength is not practical. The MC method randomly samples and optimizes the coupling in superconducting quantum circuits.

This stochastic or probabilistic approach efficiently navigates the parameter values to maximize the fidelity of QST. The process is iterative, and the coupling strength is adjusted on probabilistic sampling and classical computing power.

Implementing a 36-qubit superconducting quantum circuit

The researchers used their optimization technique to employ a 2D 6x6 superconducting qubit network, i.e., a network containing 36 qubits.

They tested this network for three types of quantum states, which they transferred.

The first was a single-excitation transfer, which means only one qubit is excited in the system. The aim is to see how this excitation is transferred across multiple qubits within the quantum system.

For single-excitation transfers, the fidelity was found to be 0.902. A fidelity of 0.902 means that the actual transferred state closely matches the desired state, with an accuracy of 90.2%.

For two-excitation transfer (two excited qubits), the fidelity rate was 0.737, which is to say that the information was transferred with an accuracy of 73.7%.

The researchers also tested their network for transferring a Bell state. A Bell state is a state of two maximally entangled qubits. When qubits are in a Bell state, their quantum properties are correlated such that if you measure the state of one qubit, you instantly know the state of the other, no matter how far apart they are.

For this case, the fidelity was found to be 0.84 between two qubit pairs. Demonstrating QST for a Bell state is crucial, as it verifies foundational quantum principles.

"We not only technically demonstrate a Monte Carlo annealing process to improve the transfer fidelity, but also reveal the underlying physical pictures from the perspectives of quantum chaotic behavior and large-spin representation," said Prof. Guo.

"Our findings are far beyond the scope of previous experiments, not only establishing a practical way to realize few-particle QST in imperfect 2D networks but also revealing the underlying physical understanding of QST from angular momentum theory and quantum ergodicity," added Dr. Xiang.

Looking ahead

The team's optimization approach works in such a way that the couplings between the qubits in a quantum network evade the manifestation of quantum chaos, which was confirmed by their experimental results.

Speaking of potential direct applications of their protocol, Prof. Mondaini and Prof. Scalettar said, "It is likely that fabrication of a future quantum device can be facilitated by connecting a collection of smaller quantum processors.

Transmission of a state within each of them and then passing the state to the

next one would form a distributed quantum processor, which could use the approach we have pioneered."

In essence, this highlights the scalability and practicality of their system for large interconnected systems.

Prof. Guo and Dr. Xiang added that their system could also provide a constructive technique for designing quantum channels and routers as building blocks for connecting processor nodes.

They said, "Building upon the high-fidelity quantum state transfer, one can implement efficient remote quantum gates across the quantum processor, thus speeding up the quantum algorithm."

Therefore, their protocol could open up possibilities for developing foundational components of quantum communication and information networks.

A team of Chinese researchers has developed a quantum computer capable of simulating the movement of electrons in solid-state materials. This achievement could pave the way for applications that surpass the capabilities of the world's fastest supercomputers.

Tracking subatomic particles like electrons is crucial to addressing numerous scientific questions, such as the principles behind magnetic attraction. Gaining insights into these fundamental sciences might help in developing high-temperature superconducting materials, potentially transforming electricity transmission and transportation.

The research was led by Pan Jianwei, who stated, "Our achievement demonstrates the capabilities of quantum simulators to exceed those of classical computers, marking a milestone in the second stage of [China's quantum computing](#) research." This statement was released by the Chinese Academy of Sciences on Thursday.

The team's research findings were published in *Nature* on Wednesday. Pan Jianwei, affiliated with the University of Science and Technology of China (USTC), co-authored the paper with colleagues Chen Yuao and Yao Xingcan.

Nature reviewers hailed the work as “an important step forward for the field.”

Stages of Quantum Computing Evolution

Quantum computing has three generally accepted stages of evolution:

Pan’s team reached the second stage by successfully simulating the fermionic Hubbard model. This model, proposed by British physicist John Hubbard in 1963, describes electron motion in lattices and is crucial for explaining high-temperature superconductivity. Supercomputers struggle with this simulation, making this achievement particularly significant.

Chen Yuao highlighted the challenge, saying, “Simulating the movement of 300 electrons using classical computers would require storage space exceeding the total number of atoms in our universe.”

To achieve their goal, Pan and his team overcame three major challenges: creating optical lattices with uniform intensity distribution, achieving low temperatures, and developing new measurement techniques to accurately characterize the states of the quantum simulator.

The team combined machine-learning optimization techniques with their earlier work on homogeneous Fermi superfluids in box-shaped optical traps to prepare degenerate Fermi gases at ultra-low temperatures. This allowed them to observe a transition in the material from a paramagnetic to an antiferromagnetic state.

This research lays the foundation for a deeper understanding of high-temperature superconductivity mechanisms. Chen Yuao explained, “Once we fully understand the physical mechanisms of high-temperature superconductivity, we can scale up the design, production, and application of new high-temperature superconducting materials. This could revolutionize fields such as electric power transmission, medicine, and supercomputing.”

Potential Applications

- **Electric Power Transmission:** Improved superconducting materials could drastically reduce energy loss in power grids.
- **Medical Technology:** High-temperature superconductors could enhance imaging technologies like MRI.
- **Supercomputing:** Quantum computing advancements could lead to more powerful and efficient supercomputers.

This breakthrough by Pan Jianwei and his team marks an advancement in quantum computing, showcasing the potential of quantum simulators to address scientific challenges that classical computers cannot handle. Their work provides a promising step

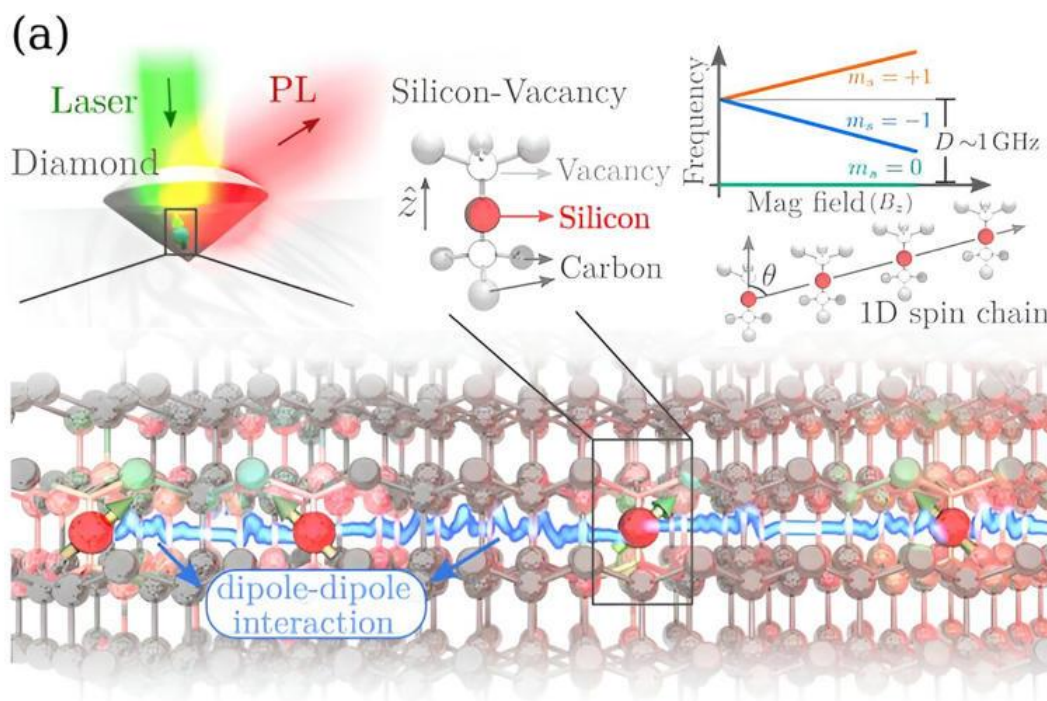

Schematic representation of Silicon-Vacancy in Diamond and the corresponding spin array of SiV's coupled through dipole-dipole interaction. Credit: Physical Review B (2024). DOI: 10.1103/PhysRevB.110.014413© Provided by Phys.org

Quantum computing, which uses the laws of quantum mechanics, can solve pressing problems in a broad range of fields, from medicine to machine learning, that are too complex for classical computers.

Quantum simulators are devices made of interacting quantum units that can be programmed to simulate complex models of the physical world. Scientists can then obtain information about these models, and, by extension, about the real world, by varying the interactions in a controlled way and measuring the resulting behavior of the quantum simulators.

In a [paper published in *Physical Review B*](#), a UC Riverside-led research team has proposed a chain of quantum magnetic objects, called spin centers, that, in the presence of an external magnetic field, can quantum simulate a variety of magnetic phases of matter as well as the transitions between these phases.

"We are designing new devices that house the spin centers and can be used to simulate and learn about interesting physical phenomena that cannot be fully studied with classical computers," said Shan-Wen Tsai, a professor of physics and astronomy, who led the research team. "Spin centers in solid state materials are localized quantum objects with great untapped potential for the design of new quantum simulators."

According to Troy Losey, Tsai's graduate student and first author of the paper, advances with these devices could make it possible to study more efficient ways of storing and transferring information, while also developing methods needed to create room temperature quantum computers.

"We have many ideas for how to make improvements to spin-center-based quantum simulators compared to this initial proposed device," he said.

"Employing these new ideas and considering more complex arrangements of spin centers could help create quantum simulators that are easy to build and operate, while still being able to simulate novel and meaningful physics."

Tsai and Losey answer questions about the research:

What is a quantum simulator?

Tsai: It is a device that exploits the unusual behaviors of quantum mechanics to simulate interesting physics that is too difficult for a regular computer to calculate. Unlike quantum computers that operate with qubits and universal gate

operations, quantum simulators are individually designed to simulate/solve specific problems.

By trading off universal programmability of quantum computers in favor of exploiting the richness of different quantum interactions and geometrical arrangements, quantum simulators may be easier to implement and provide new applications for quantum devices, which is relevant because quantum computers aren't yet universally useful.

A spin center is a roughly atom-sized quantum magnetic object that can be placed in a crystal. It can store quantum information, communicate with other spin centers, and be controlled with lasers.

What are some applications of this work?

Losey: We can build the proposed quantum simulator to simulate exotic magnetic phases of matter and the phase transitions between them. These phase transitions are of great interest because at these transitions the behaviors of very different systems become identical, which implies that there are underlying physical phenomena connecting these different systems.

The techniques used to build this device can also be used for spin-center-based quantum computers, which are a leading candidate for the development of room temperature quantum computers, whereas most quantum computers require extremely cold temperatures to function.

Furthermore, our device assumes that the spin centers are placed in a straight line, but it is possible to place the spin centers in up to 3-dimensional arrangements. This could allow for the study of spin-based information devices that are more efficient than methods that are currently used by computers.

As quantum simulators are easier to build and operate than quantum computers, we can currently use quantum simulators to solve certain problems that regular computers don't have the abilities to address, while we wait for quantum computers to become more refined.

However, this doesn't mean that quantum simulators can be built without challenge, as we are just now getting close to being good enough at manipulating spin centers, growing pure crystals, and working at low temperatures to build the quantum simulator that we propose.

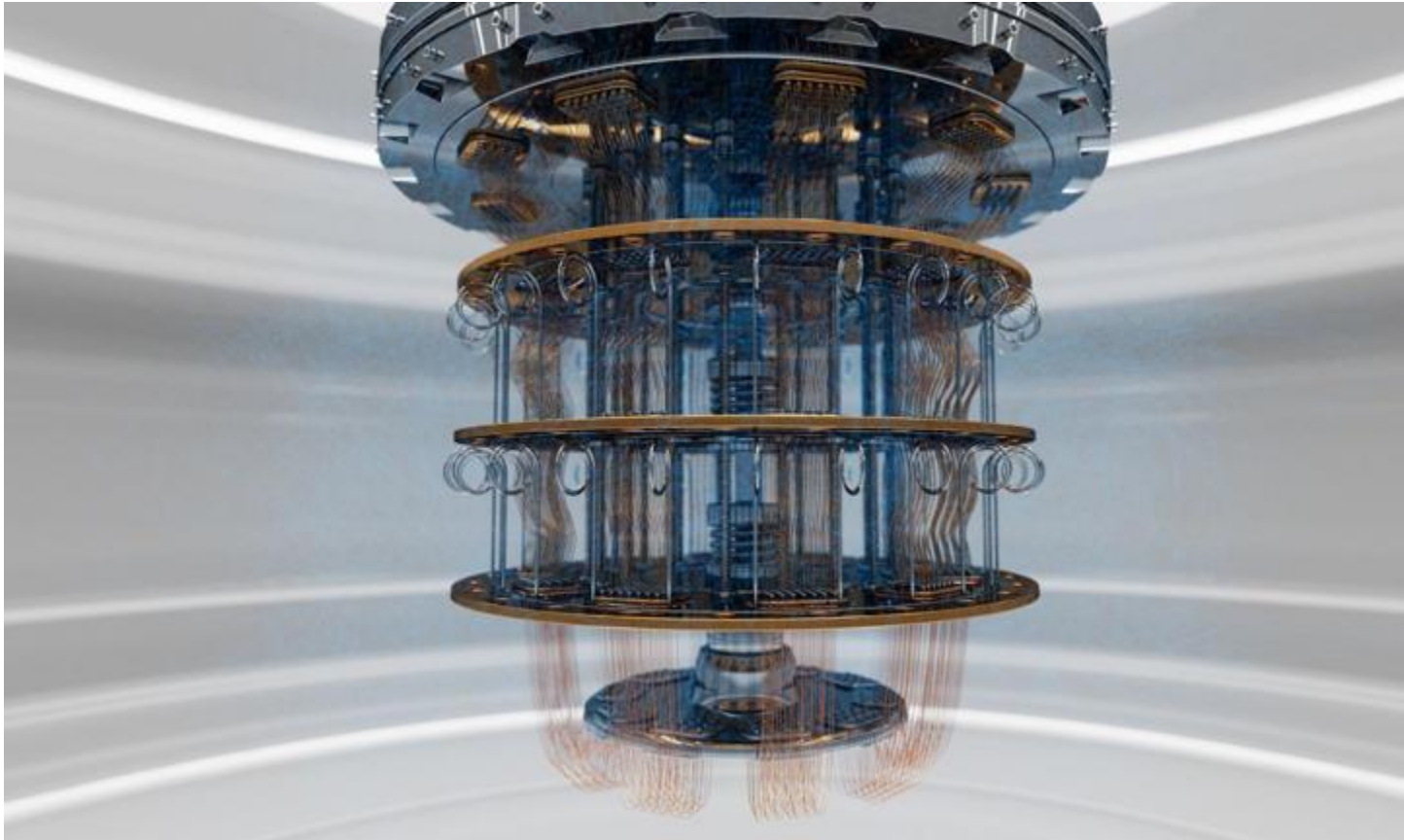

Scientists beat supercomputers with quantum tech that simulates electron motion© Provided by Interesting Engineering

A Chinese research team has achieved a significant milestone in quantum computing by successfully building a device that can simulate the movement of electrons within a solid-state material.

This research, published in the journal *Nature*, showcases the potential of quantum computers to surpass even the most powerful supercomputers.

Understanding electron behavior is crucial for scientific advancements, particularly in the fields of magnetism and high-temperature superconducting materials. These materials could revolutionize electricity transmission and transportation, leading to significant energy savings and technological progress.

“Our achievement demonstrates the capabilities of quantum simulators to exceed those of classical computers, marking a milestone in the second stage of China’s quantum computing research,” said team leader Pan Jianwei from the University of Science and Technology of China.

For reference, the second stage of quantum computing focuses on developing specialized quantum simulators. These simulators are designed to tackle specific scientific problems that are too complex for classical computers to handle efficiently.

A complex challenge

The research team focused on simulating the fermionic Hubbard model (FHM). It is a theoretical model describing electron motion within lattices, proposed by British physicist John Hubbard in 1963.

However, despite its importance in explaining high-temperature superconductivity, this model is notoriously difficult to simulate due to its complexity.

Besides, there is no exact solution for this model in two or three dimensions, and even the most powerful supercomputers struggle to explore its full parameter space due to high computational demands.

Chen Yuao, a co-author of the paper, [explained](#) that simulating the movement of 300 electrons using classical computers would require storage space exceeding the total number of atoms in the universe.

Overcoming challenges in quantum simulation

[Quantum](#) simulation involves using ultracold fermionic atoms in optical lattices to map out the low-temperature phase diagram of the FHM.

However, previous quantum simulation experiments faced challenges in realizing the antiferromagnetic phase transition due to the difficulty in cooling fermionic atoms and the inhomogeneity introduced by standard Gaussian-profile lattice lasers.

To overcome the challenges associated with simulating the Hubbard model, the team combined machine-learning optimization techniques with their previous work on homogeneous Fermi superfluids.

This enabled them to create optical lattices with uniform intensity distribution, achieve ultra-low temperatures, and develop new measurement techniques to characterize the states of the quantum simulator accurately.

Breakthrough observation, promising future

The research culminated in the observation of a switch in a material from a paramagnetic state (weakly attracted to a magnet) to an antiferromagnetic state (largely insensitive to a magnet). This finding can further our understanding of [high-temperature](#) superconductivity mechanisms.

“Once we fully understand the physical mechanisms of high-temperature superconductivity, we can scale up the design, production, and application of new high-temperature superconducting materials, potentially revolutionizing fields such as electric power transmission, medicine, and supercomputing,” stated Chen while emphasizing the potential impact of this research.

This breakthrough marks a significant step forward in quantum computing research. It can immensely contribute to developing specialized quantum simulators to tackle scientific problems beyond the capabilities of classical computers

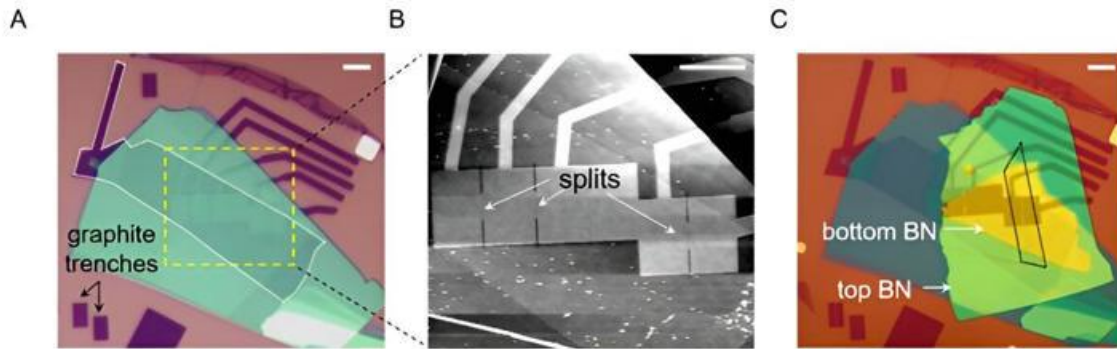

Device fabrication. A, An optical image of the K22 stack including the etched graphite bottom split gates and trenches made for alignment. The white dashed line outlines the graphite global gate (GG). B, AFM image of the area inside the yellow box in A. In areas of interest, the surface is clean of polymer residue. The widths of the splits vary from 74 to 90 nm, as measured by AFM. C, An optical image of K22 after the transfer of the h-BN/BLG/h-BN stack. Credit: Science (2024). DOI: 10.1126/science.adj3742© Provided by Phys.org

The key to developing quantum electronics may have a few kinks. According to a team led by researchers at Penn State, that's not a bad thing when it comes to the precise control needed to fabricate and operate such devices, including advanced sensors and lasers.

The researchers fabricated a switch to turn on and off the presence of kink states, which are electrical conduction pathways at the edge of semiconducting materials. By controlling the formation of the kink states, researchers can regulate the flow of electrons in a quantum system.

"We envision the construction of a quantum [interconnect](#) network using the kink states as the backbone," said team leader Jun Zhu, professor of physics at Penn State. Zhu is also affiliated with Penn State's Center for 2-Dimensional Layered Materials.

"Such a network may be used to carry quantum information on-chip over a long distance, for which a classical copper wire won't work because it has resistance and therefore cannot maintain quantum coherence."

The work, published in [Science](#), potentially provides a foundation for researchers to continue investigating kink states and their application in electron quantum optics devices and quantum computers.

"This switch operates differently from a conventional switch, where the electrical current is regulated through a gate, similar to traffic through a toll plaza," Zhu said. "Here, we are removing and rebuilding the road itself."

Kink states exist in a quantum device built with a material known as Bernal bilayer graphene. This comprises two layers of atomically thin carbon stacked together in such a way that the atoms in one layer are misaligned with the atoms in the other. This arrangement, together with the use of an electric field, creates unusual electronic properties—including the quantum valley Hall effect.

This effect refers to the phenomenon of electrons occupying different "valley" states—identified based on their energy in relation to their momentum—also moving in opposing forward and backward directions. Kink states are manifestations of the quantum valley Hall effect.

"The amazing thing about our devices is that we can make electrons moving in opposite directions not collide with one another—which is called backscattering—even though they share the same pathways," said first author Ke Huang, a graduate student pursuing a doctorate in physics at Penn State under Zhu's mentorship.

"This corresponds to the observation of a 'quantized' resistance value, which is key to the potential application of the kink states as quantum wires to transmit quantum information."

While the Zhu lab has [published on the kink states before](#), they only achieved the quantization of the quantum valley Hall effect in the current work after improving the electronic cleanness of the devices, meaning they removed sources that could allow electrons moving in opposite directions to collide.

They did this by incorporating a clean graphite/hexagonal boron nitride stack as a global gate—or a mechanism that can allow the flow of electrons—into the devices.

Both graphite and hexagonal boron nitride are compounds commonly used as lubricants for paints, cosmetics and more. Graphite conducts electricity well while hexagonal boron nitride is an insulator. The researchers used this combination to contain electrons to the kink states and control their flow.

"The incorporation of a graphite/hexagonal boron nitride stack as a global gate is critically important to the elimination of electron backscattering," Huang said, noting that this material use was the key technical advancement of the current study.

The researchers also found that the quantization of the kink states remains even when the temperature is raised to several tens of Kelvin, the scientific unit of temperature. Zero Kelvin corresponds to -460 degrees Fahrenheit.

"Quantum effects are often fragile and only survive at cryogenic temperatures of a few Kelvin," Zhu said. "The higher temperature we can make this work, the more likely it can be used in applications."

The researchers experimentally tested the switch they built and found that it could quickly and repeatedly control the current flow. This adds to the [arsenal of kink state-based quantum electronics widgets](#) that help control and direct electrons—valve, waveguide, beam splitter—previously built by the Zhu lab.

"We have developed a quantum highway system that could carry electrons without collision, be programmed to direct current flow and is potentially scalable—all of which lays a strong foundation for future studies exploring the fundamental science and application potentials of this system," Zhu said. "Of course, to realize a quantum interconnect system, we still have a long way to go."

Zhu noted that her lab's next goal is to demonstrate how electrons behave like coherent waves when traveling on the kink state highways.



Fascinating behavior of 'super photons' in the quantum realm© Provided by Earth

Have you ever wondered what happens when thousands of particles of light merge into a single entity? This phenomenon, known as a "super photon," has fascinated physicists for years.

Now, researchers have made an intriguing discovery that broadens our understanding of this [exotic quantum state](#).

Dr. Julian Schmitt and his colleagues from the Institute of Applied Physics at the [University of Bonn](#) have shown that photon Bose-Einstein condensates, also known as quantum gases, obey a fundamental theorem of physics.

Their findings, published in the journal *Nature Communications*, open up new possibilities for measuring properties of these enigmatic entities that were previously difficult to access.

Birth of a super photon

To create a super photon, [Bose-Einstein](#) condensate, the researchers filled a tiny container with a dye solution and surrounded it with highly reflective walls.

They then excited the dye molecules with a laser, producing photons that bounced back and forth between the surfaces.

As the particles of light repeatedly collided with the dye molecules, they cooled down and finally condensed into a quantum gas.

But the process doesn't stop there. The particles of the super photon continue to collide with the dye molecules, being swallowed up and spat out again, causing the quantum gas to flicker like a candle.

This flickering became the key to unlocking the secrets of the photon Bose-Einstein condensate.

Understanding quantum gases and super photons

Quantum gases are a fascinating state of matter that emerge when a collection of particles, such as atoms or photons, are cooled to extremely low temperatures near absolute zero.

At these temperatures, the quantum mechanical properties of the particles become dominant, leading to unique and counterintuitive behaviors.

Several things are important to know about quantum gases:

Bose-Einstein condensate (BEC)

When certain types of particles (bosons) are cooled to near absolute zero, they can collapse into a single quantum state, forming a Bose-Einstein condensate. In a BEC, the particles lose their individual identities and behave as a single, coherent entity.

Fermionic quantum gases

Quantum gases can also be formed using fermions, particles with half-integer spin. Unlike bosons, fermions obey the Pauli exclusion principle, which states that no two identical fermions can occupy the same quantum state simultaneously. Fermionic quantum gases exhibit different properties than Bose-Einstein condensates.

Superfluidity

Some quantum gases, such as those composed of helium-4 atoms, can [exhibit superfluidity](#). In a superfluid state, the gas flows without friction and can even climb up the walls of its container.

Quantum simulations

Quantum gases provide a powerful platform for simulating complex [quantum systems](#). By manipulating the interactions between the particles in a quantum gas, researchers can model and study phenomena that are difficult to observe directly, such as superconductivity and quantum magnetism.

Precision measurements

The unique properties of quantum gases make them ideal for precision measurements. For example, atomic clocks based on quantum gases are among the most accurate timekeeping devices in the world.

Finally, quantum gases have potential applications in [quantum information](#) processing, where they could be used to store and manipulate [quantum bits](#) (qubits) for quantum computing and communication.

Super photons are like a campfire

To understand the behavior of the super photon, the researchers drew an analogy to a campfire. Imagine a fire that sometimes randomly flares up very strongly.

After the blaze, the flames slowly die down, and the fire returns to its original state. Interestingly, you can also cause the fire to flare up intentionally by blowing air into the embers.

The regression theorem predicts that the fire will continue to burn down in the same way, regardless of whether the flare-up occurred randomly or was intentionally caused.

In other words, it responds to the perturbation in exactly the same way as it fluctuates on its own without any perturbation.

Testing the super photon theorem

The researchers set out to determine whether this behavior also applies to quantum gases. They measured the flickering of the super photons to quantify the statistical fluctuations and then gently perturbed the system by briefly firing another laser at the super photon.

"We were able to observe that the response to this gentle perturbation follows precisely the same dynamics as the random fluctuations without a perturbation," says Dr. Schmitt.

"In this way, we were able to demonstrate for the first time that this theorem also applies to exotic forms of matter as quantum gases."

Interestingly, the theorem remains valid even for strong perturbations. Systems usually respond differently to stronger perturbations than they do to weaker ones, a phenomenon known as nonlinear behavior.

However, the researchers, in collaboration with colleagues from the [University of Antwerp](#), found that the theorem holds true even in these cases.

Diving deep into the unknown

The findings have significant implications for fundamental research with photonic quantum gases. Often, researchers don't know precisely how these entities will flicker in their brightness.

By studying how the super photon responds to controlled perturbations, they can learn about unknown properties under very controlled conditions.

"It will enable us, for example, to find out how novel photonic materials consisting of many super photons behave at their core," explains Dr. Schmitt.

As we continue to explore the fascinating world of [quantum physics](#), discoveries like this bring us one step closer to unraveling the mysteries of the universe.

The secret life of super photons may hold the key to unlocking new frontiers in science and technology, and we can't wait to see where this journey takes us next.

From neurons to network: Building computers inspired by the brain

Story by Tejasri Gururaj

The human brain's processing power is exceptional. It can perform a billion mathematical operations in one second using just [20 Watts of power](#).

Researchers are now trying to capture this efficiency by building computers inspired by the human brain's operation and function. This field, known as [neuromorphic computing](#), uses artificial synapses and neurons to process information.

Although this is still an emerging area of research, a new study has announced a leap. Researchers from the Center for Neuromorphic Engineering at the Korea Institute of Science and Technology (KIST) have implemented an integrated hardware system consisting of artificial neurons and synaptic devices using hexagonal boron nitride (hBN) material.

They aimed to construct building blocks of [neuron-synapse-neuron](#) structures that can be stacked to develop large-scale artificial neural networks.

"Artificial neural network hardware systems can be used to efficiently process vast amounts of data generated in real-life applications such as smart cities, healthcare, next-generation communications, weather forecasting, and autonomous vehicles," said KIST's Dr. Joon Young Kwak, one of the study's authors, in a [press release](#).

But what is the problem with classical computing, and how is neuromorphic computing mimicking the brain?

Shortcomings of classical computing

One reason scientists are exploring alternate computing paradigms is the limitations of present-day computing. While [present-day computers](#) are

impressive, they require high power, have limited scalability, and have limited parallelism.

These drawbacks mean that these computers are not efficient, and one reason is the von Neumann architecture of computers today.

If you look at computers today, [memory and data processors](#) are two different units connected by a narrow channel called the bus. This means that any time a computation has to be done, data is transferred between the memory and data processing center, which is the CPU or central processing unit.

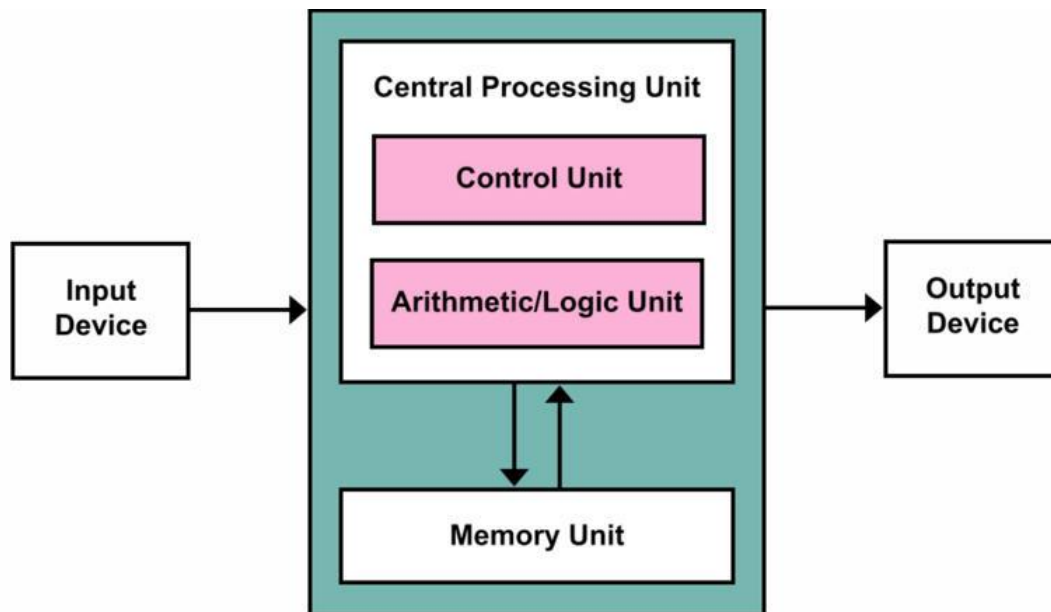

The von Neumann architecture. Credit: Kapooht/Wikimedia Commons .© Provided by Interesting Engineering

The flow of data back and forth creates a bottleneck in performance that worsens as the computations get more complex, lowering the efficiency of the overall system. This is known as the von Neumann bottleneck and affects most present-day computers.

Overcoming limitations

Neuromorphic computing doesn't have any of these problems due to many reasons.

1. Parallel computing: Like the brain, these systems can perform multiple tasks simultaneously, which means we get faster computers.

2. Low power: These systems, like the brain, are designed to use the least amount of power for computations.
3. Adaptability: When the brain receives input signals (essentially information), it learns from them. Neuromorphic systems share this adaptability, enhancing their efficiency and making them more flexible for tasks such as classification or pattern recognition.
4. Fault-tolerant: One of the cool things about these systems is that failure in one portion of the system will not affect the system's overall functioning. This is because their architecture is distributed and decentralized, which means a damaged neuron or synapse won't stop the operation.

Let's move on to the heart of the matter.

Information processing in the brain

Modeling neurons and synapses is the most critical aspect of developing neuromorphic systems. To understand how artificial ones are constructed, we first need to comprehend how the real ones function in the brain.

Neurons are cells responsible for sending signals or information throughout the body. They allow us to do activities like breathing, sleeping, and watching our favorite TV shows.

For this article, we will focus on the neuron's three main parts: dendrites, axons, and axon terminals.

Dendrites are branch-like protrusions that receive and transmit signals from and to other neurons. They are the first step in information processing. This information is then sent to the soma (or cell body), which integrates the signals and sends them along the axon.

Like an electrical wire, the axon is a fiber that conducts electricity. Finally, the signal reaches the [axon terminals](#), after which it is passed on to the next neuron.

Tiny gaps between neurons, specifically axon terminals, form synapses. These gaps enable the transmission of information between neurons. When signals are being transmitted or received, chemicals called neurotransmitters, which let the [neurons talk](#) to each other, are released in the synapses.

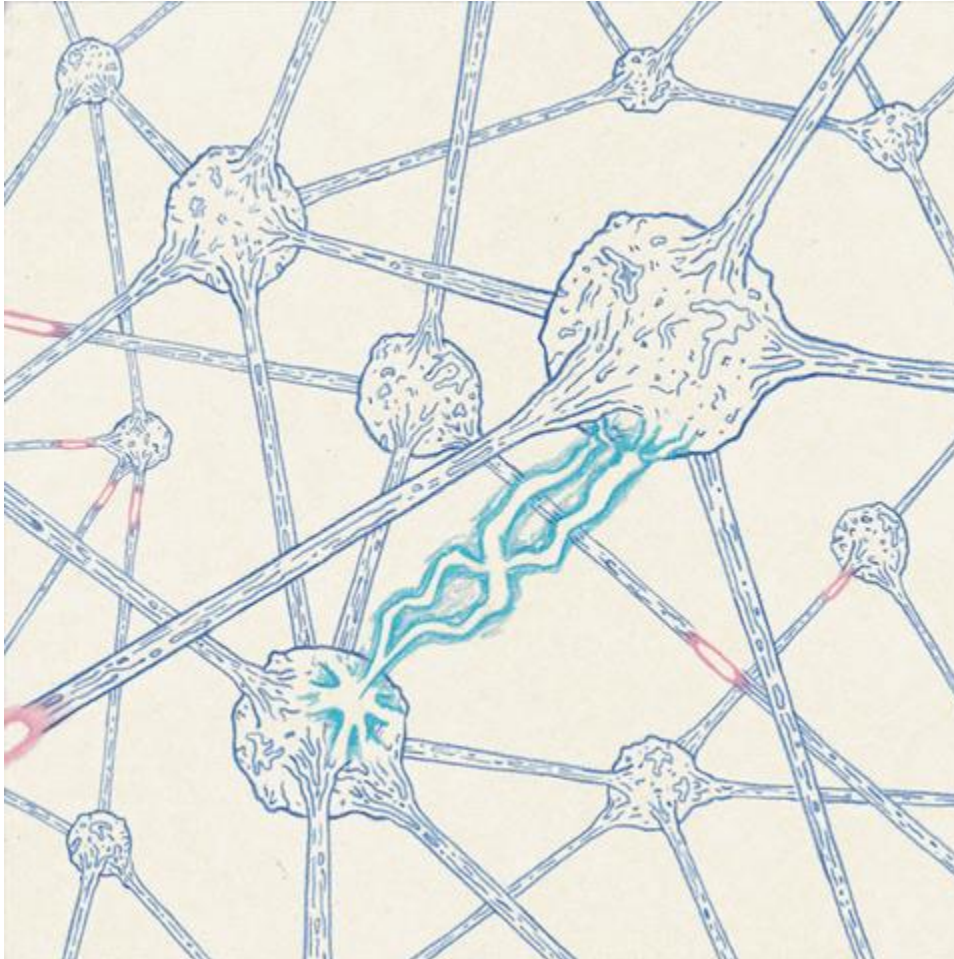

Pink And Blue Animation GIF by palerlotus - Find & Share on GIPHY© Provided by Interesting Engineering

Mimicking the brain

Replicating this process is challenging and requires precise accuracy in many aspects.

1. Integration of signals and crossing the threshold: A neuron doesn't always fire or transmit information. If and only if the integrated signal crosses a threshold value, does the output signal get generated?

2. Information leaks: The information received by the neurons gradually leaks over time. In other words, it may take longer for the neuron to *fire*. Firing means that the neuron is sending a signal.
3. Synaptic plasticity: The strength of the synaptic connection can change over time depending upon the firing of the two neurons it connects. Essentially, this means the information being passed can be modified in real-time. This is key for the adaptability of the networks.

Memristors and modeling the brain

The researchers relied on memristors to [model the artificial neurons](#) and synaptic devices, which can mimic synaptic activity.

Memristors, or memory resistors, can regulate current flow by *remembering* their resistance state. In other words, the resistance changes when a current passes through it, but it remains even after the power is switched off.

For the artificial neurons, it was necessary to pick a device that would leak information over time to mimic the leaky behavior of neurons. They chose resistive random access memory or RRAM based on the memristor.

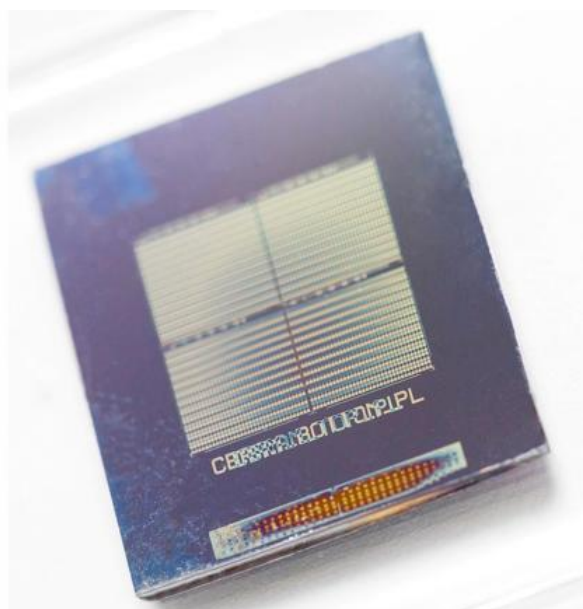

An example of a memristor device. Credit: US Department of Energy .© Provided by Interesting Engineering

[RRAMs are devices](#) that allow for dynamic changes in resistance during operation. Like traditional RAMs, information can be written and read in any order.

They chose volatile RRAMs for the neurons. These devices can change their resistance while operating, but the resistance is eventually lost after the power has been switched off.

On the other hand, the researchers chose non-volatile RRAMs for the synaptic devices. These devices can retain the resistive state even after the power is turned off. This emulates the stable connections between neurons but also mimics the plasticity of synapses by allowing the resistance to change during operation.

The material used to build the devices was the [two-dimensional material](#), hBN. The researchers chose it because it consumes very low power, offers high integration and scalability, and has been shown to work very well for memristor-based devices like the RRAMs.

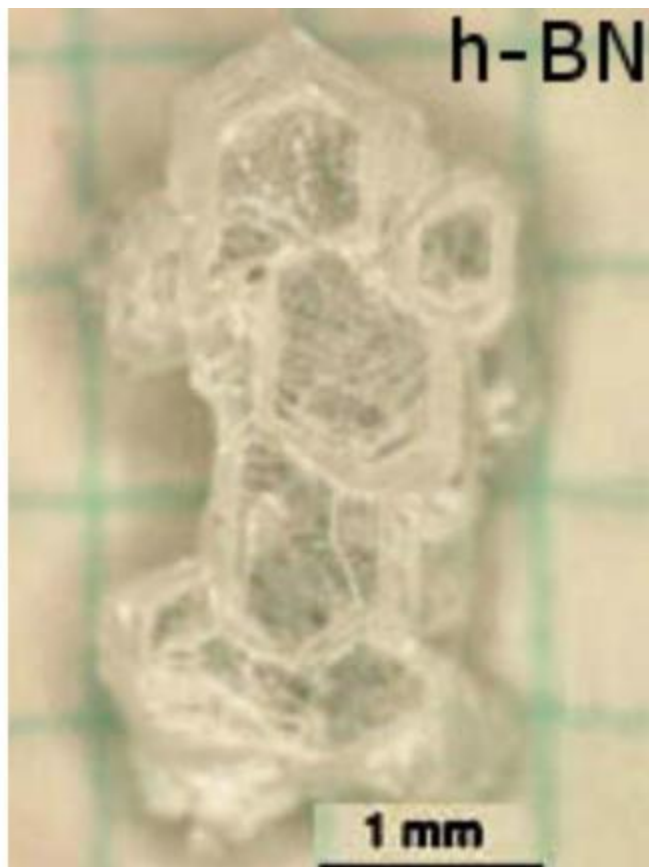

Crystals of hBN. Credit: NIMSooffice/Wikimedia Commons .© Provided by Interesting Engineering

So now we have our neurons and synapses. The researchers used the neuron-synapse-neuron setup as a building block or Lego block, which they could use to build an entire network.

Implementing and testing a hardware neural network

The final step was assembling the Lego set. The team used their neuro-synapse-neuron setup to construct a physical artificial neural network, the first of its kind using neurons and synaptic devices built to mimic their biological counterparts.

The researchers tested their network using the MNIST dataset. This large dataset consists of handwritten digits (0-9) and is commonly used for testing machine learning algorithms on classification tasks.

They implemented a spiking [neural network](#) with an input layer of 784 neurons, a hidden layer of 100 neurons, and an output layer of 10 neurons. The input layer had 784 neurons because each image in the MNIST dataset has 28 by 28 pixels, and to encode each pixel, we need one neuron.

The output layer has 10 neurons because the network needs to classify ten digits. This is identical to artificial neural networks in machine learning.

Their network classified the digits with an accuracy of 83.45 percent, which was close to the accuracy of their ideal case scenario, which was 90.65 percent.

For perspective, most modern machine learning algorithms have demonstrated accuracies of over 99 percent with the MNIST data set. However, it is crucial to remember that this is a physical implementation of these networks and may be affected by noise or other hardware imperfections.

Where will we see neuromorphic computing?

Despite still being in the early stages of development, neuromorphic computing already has many [potential applications](#) that could hugely affect various industries.

Since these systems are receptive to environmental changes, they could play a huge role in autonomous systems such as vehicles and drug delivery systems.

Cars will be able to sense their environment, making the driverless experience safer and more energy-efficient. This is also true for IoT devices like sensors, security cameras, and thermostats.

Similarly, drug delivery systems must consume low power or have a self-powered mechanism because we can't send massive power sources inside the human body. This means that neuromorphic systems will have a crucial role to play.

These systems, once integrated with organic materials, can also be used [in prosthetics](#).

Neuromorphic computing could also be used in large-scale operations and artificial intelligence. These tasks demand fast and efficient operations, which neuromorphic systems excel at, particularly in pattern recognition and decision-making.

Dr. Young also mentioned in the press release that "it will help improve environmental issues such as carbon emissions by significantly reducing energy usage while exceeding the scaling limits of existing silicon CMOS-based devices."

In summary, this technology holds immense potential, but there is still progress to be made. [This study](#), published in *Advanced Functional Materials*, has shown that scientists are making strides in the right direction.



Quantum computing breakthrough achieved with on-chip pulse generator© Provided by Interesting Engineering

Quantum computing has, for a while now, been heralded as the future of complex problem-solving. It is touted as the harbinger of doom for today's encryption systems. However, scaling effectively has been an Achilles heel.

The field currently grapples with the challenge of scaling quantum computers to millions of qubits. This scale is essential for executing fully error-corrected quantum algorithms and advancing noisy intermediate-scale quantum applications. Moreover, the existing methods for readout and manipulation of qubits are both cost-intensive and cumbersome.

In present systems, microwave signals are transmitted from room-temperature electronics to quantum chips housed within cryogenic dilution fridges at millikelvin temperatures. This involves routing these signals through coaxial cables, a method that becomes impractical beyond a certain point.

While it is feasible to extend this setup to around 1,000 qubits, scaling beyond incurs costs and heat load significantly, reports [AZoQuantum](#).

The critical bottleneck here is traditional architecture, which cannot handle the extensive wiring and the heat dissipation that comes with scaling to this extent.

A promising solution

Monolithic integration can be a solution to this issue. By tightly integrating qubits with control and microwave electronics and replacing macroscale wiring with chip stackings and circuit blocks, this approach can reduce both passive heat load and system footprint.

Monolithic integration offers systematic advantages such as improved signal fan-out and fan-in capabilities and reduced communication latency. Additionally, it minimizes the reliance on extensive wiring harnesses— a major source of heat load and complexity.

However, it requires a coherent cryogenic microwave pulse generator that is compatible with superconducting quantum circuits. A new study reveals such a signal source driven by digital-like signals, generating pulsed [microwave emission](#) with well-controlled phase, intensity, and frequency directly at millikelvin temperatures.

The team behind this research proposes an on-chip coherent cryogenic microwave pulse generator. They used [superconducting](#) circuits within a vacuum process to gain precise control over the frequency, intensity, and phase by digitally manipulating magnetic flux across a superconducting quantum interference device (SQUID) embedded in a superconducting resonator.

The team's device consists of a $\lambda/2$ coplanar waveguide resonator with a SQUID embedded in its center conductor. The SQUID, featuring two parallel Josephson junctions, acts as a tunable inductor and allows the resonator's properties to be adjusted through variation of the magnetic flux.

The total inductance of the SQUID-embedded resonator included both the flux-dependent SQUID inductance and the coplanar waveguide resonator inductance. For the readout, a three-dimensional (3D) circuit quantum electrodynamics architecture was employed.

In their experiments, the researchers used room temperature junction resistances ranging from 50Ω to 270Ω , corresponding to inductances of 58 pH to 310 pH at zero flux. These values accounted for 3.1% to 11.6% of the total inductance of the SQUID-embedded resonators.

To drive the pulse generator, the team employed an arbitrary waveform generator with a 1 GHz sampling rate. This generator delivered the necessary flux step/overshoot to the signal source in the cryogenic environment. The output of the cryogenic microwave source was then amplified by using a series of amplifiers at different temperature stages.

Impact and prospects

The team's on-chip coherent cryogenic microwave pulse generator showcased exceptional coherence in generating microwave photon pulses. This is a significant advancement over previous microwave photon sources used in cryogenic environments.

This high coherence enables convenient superposition, allowing a wide range of microwave signals to be created. This breakthrough could potentially lead to superconducting quantum computers implemented on a large scale.

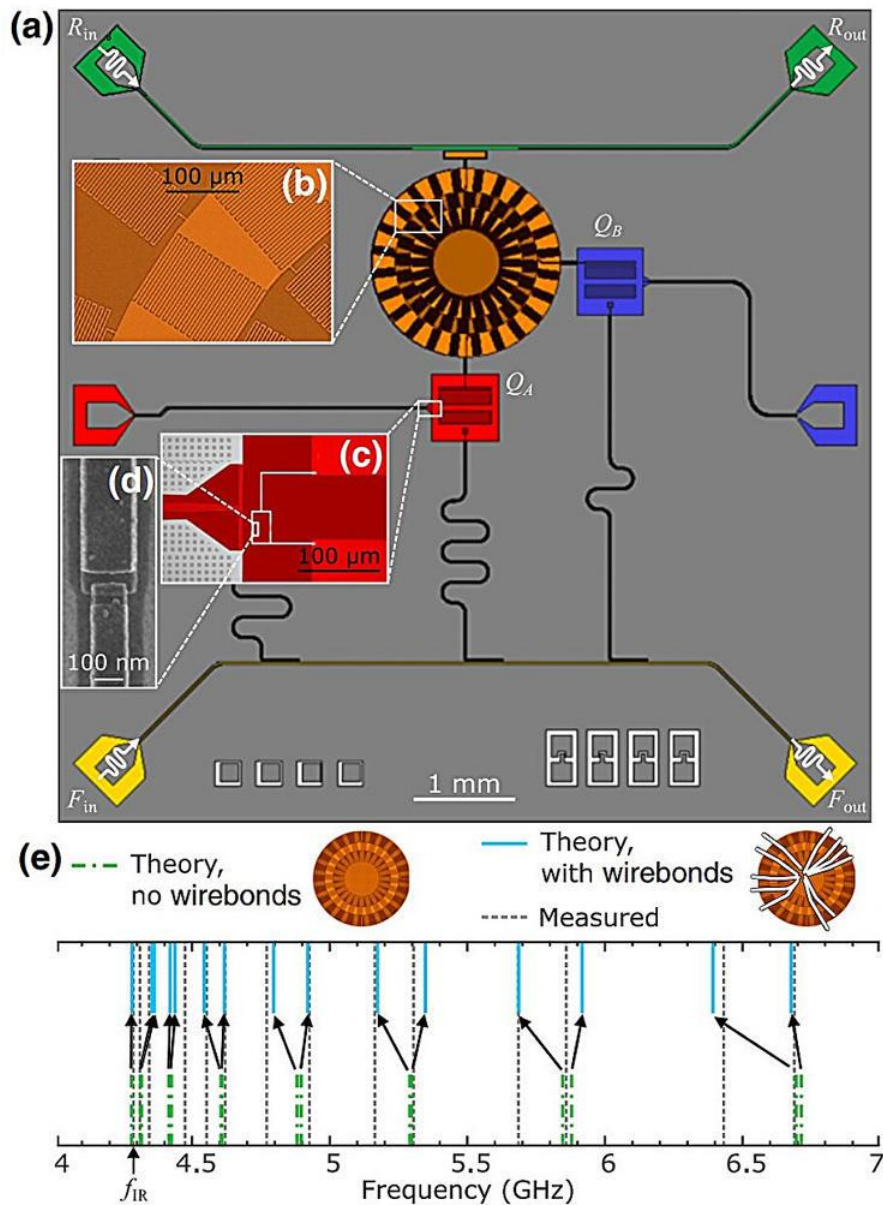

(a) The chip layout for the metamaterial ring-resonator device. (b),(c) Optical micrographs of the device with false-color highlighting. (d) An SEM image of a Josephson junction in a qubit. The device has two flux-tunable transmon qubits, Q_A and Q_B , coupled to a ring resonator at the positions indicated: R_{in}/R_{out} connections to the upper feed line used to probe ring-resonator modes and F_{in}/F_{out} connections used for measuring readout resonators coupled to each qubit. (e) The measured ring-resonator mode frequencies are shown with gray dashed lines. The theoretical mode frequencies are shown with green dashed-dotted lines when stray inductance due to wirebonds is not included and any degeneracy lifting is due to the qubits or the feed line. The solid blue lines show the large degeneracy-lifting effect of wirebonds on the ring-resonator mode frequencies. Credit: PRX Quantum (2024). DOI: 10.1103/PRXQuantum.5.020325© Provided by Phys.org

Implementing a fault-tolerant quantum processor requires coupling qubits to generate entanglement. Superconducting qubits are a promising platform for quantum information processing, but scaling up to a full-scale quantum computer necessitates interconnecting many qubits with low error rates. Traditional methods often limit coupling to nearest neighbors, require large physical footprints, and involve numerous couplers, complicating fabrication.

For instance, coupling 100 qubits pairwise demands a vast number of couplers. Moreover, controlling individual circuit elements and couplers with separate cables for even 1,000 qubits would require an impractically large volume of cables, making it infeasible to fit such a system in a large lab, let alone manage millions of qubits. This highlights the need for more efficient and scalable coupling methods.

A team of theoretical physicists led by Mohd Ansari at FZJ, in collaboration with the experimental team of Britton Plourde at Syracuse University, introduced a novel approach using a multimode coupler that enables tunable coupling strength between any pair of qubits.

[Published](#) in *PRX Quantum*, this research utilizes a shared coupler shaped like a ring, made from a metamaterial transmission line. This design produces a dense frequency spectrum of standing-wave resonances near the qubit transition frequency range. The left-handed ring resonator, composed of 24 inductively grounded and capacitively coupled cells, exhibits a dense set of modes above a minimum cutoff frequency, with mode frequencies spreading further apart at higher frequencies.

This unique design, where the frequency of standing waves is linearly proportional to their wavelength, contrasts with conventional standing waves. For instance, doubling the frequency doubles the wavelength, unlike typical systems where doubling the frequency halves the wavelength. Imagine a musical instrument where higher pitches correspond to longer wavelengths—this concept defies traditional expectations.

Two superconducting qubits placed at the 3 and 6 o'clock positions on the ring resonator couple to the standing waves, with interaction strength depending on the standing-wave amplitude at their locations. Coupling multiple qubits to a common resonant mode induces transverse exchange interactions, with coupling depending on each qubit's detuning to various modes. These interactions can be positive or negative. Additionally, interactions between higher excited states of each qubit and the coupling modes result in higher-order ZZ interactions, which also vary with qubit detuning and can change sign.

This variability in exchange and ZZ interactions aligns well with theoretical models, allowing the tuning of entangling energy scales from large values to zero. The potential to extend this system to more than two qubits around the ring makes it a promising platform for controlling entanglement in large qubit arrays.

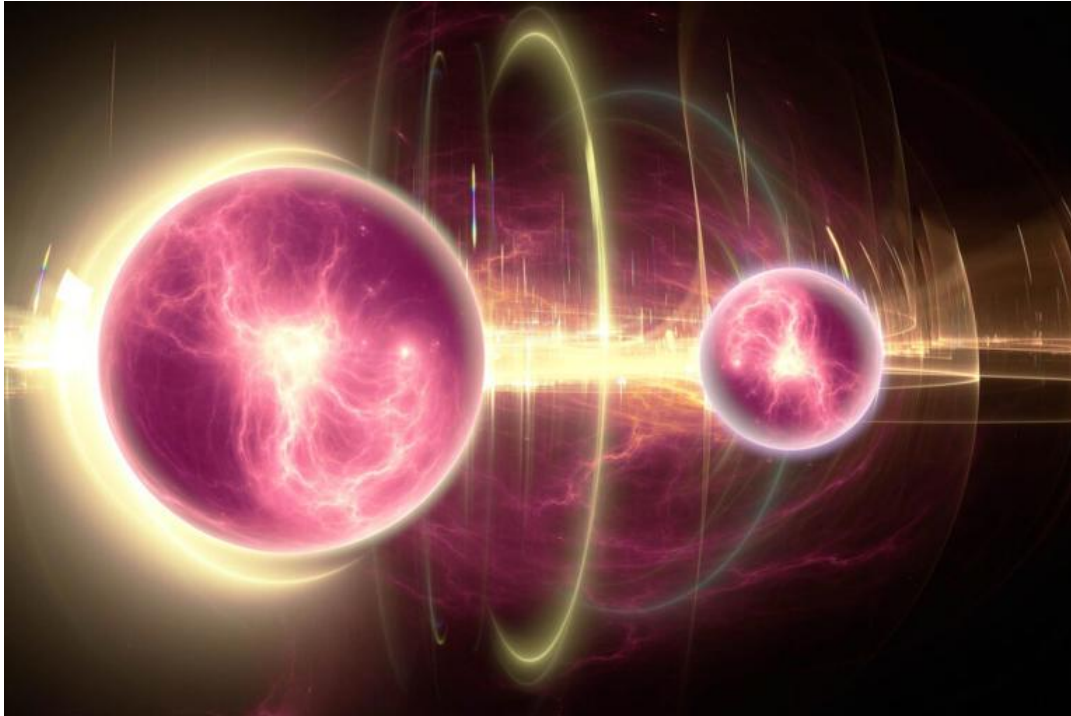

Quantum entanglement does, in fact, follow a rule of entropy© Provided by Earth

Researchers have uncovered a fundamental connection between [quantum entanglement](#), entropy, and the laws of thermodynamics. This discovery sheds new light on the behavior of quantum systems and could have far-reaching implications for the development of quantum technologies.

When quantum entanglement met the rule of entropy

Bartosz Regula from the [RIKEN](#) Center for Quantum Computing and Ludovico Lami from the [University of Amsterdam](#) have made a significant breakthrough in understanding the nature of quantum entanglement.

Through probabilistic calculations, they have shown that there is indeed a rule of entropy governing this enigmatic phenomenon.

"Our findings mark significant progress in understanding the basic properties of entanglement, revealing fundamental connections between entanglement and thermodynamics, and crucially, providing a major simplification in the understanding of entanglement conversion processes," said Regula.

Second law of thermodynamics and quantum systems

The second law of thermodynamics, which states that a system can never move to a state with lower entropy, is one of the most fundamental [laws of nature](#). It creates the "arrow of time" and encapsulates the dynamics of even the most complex physical systems.

However, as we delve deeper into the quantum world, it becomes increasingly important to understand how this law applies to quantum systems.

Quantum entanglement, a key resource that underlies much of the power of future [quantum computers](#), has been the focus of research in quantum

information science for decades. Despite its significance, little is currently understood about the optimal ways to make effective use of it.

Probabilistic transformations and reversible entanglements

The difficulty in establishing a "second law" for quantum entanglement lies in the fact that entanglement transformations must be made reversible, just like work and heat can be interconverted in thermodynamics.

However, ensuring the reversibility of entanglement is much more challenging than in the case of thermodynamic transformations.

Previous attempts at establishing a reversible theory of [entanglement](#) have failed, and it was even suspected that entanglement might be irreversible. This made the quest for a "second law" of entanglement seem like an impossible one.

Key to reversible quantum connections

Regula and Lami solve this long-standing conjecture by using [probabilistic entanglement](#) transformations. These transformations are only guaranteed to be successful some of the time, but in return, they provide an increased power in converting quantum systems.

Under such processes, the authors show that it is indeed possible to establish a reversible framework for entanglement manipulation.

They identify a setting in which a unique entropy of entanglement emerges, and all entanglement transformations are governed by a single quantity.

The methods they used could be applied more broadly, showing similar reversibility properties for more general [quantum resources](#) as well.

"This not only has immediate and direct applications in the foundations of quantum theory, but it will also help with understanding the ultimate limitations on our ability to efficiently manipulate entanglement in practice," Regula explained.

Entanglement entropy as a new frontier

While this discovery marks a significant milestone in understanding the basic properties of [entanglement](#), there is still much to be explored.

Regula notes that even stronger forms of reversibility have been conjectured, and there is hope that entanglement can be made reversible under weaker assumptions than those made in their work, without relying on probabilistic transformations.

"Understanding the precise requirements for reversibility to hold thus remains a fascinating open problem," Regula concluded.

Quantum leap into the future

In summary, the important discovery by Bartosz Regula and Ludovico Lami marks a significant milestone in our understanding of quantum entanglement and its relationship to the fundamental laws of thermodynamics.

Their work provides a new framework for analyzing and manipulating entanglement while opening exciting avenues for future research.

As we continue to explore the quantum world and harness its potential for revolutionary technologies, this finding will undoubtedly serve as a guiding light, illuminating the path towards a deeper understanding of the complex and fascinating phenomena that lie at the heart of quantum mechanics.

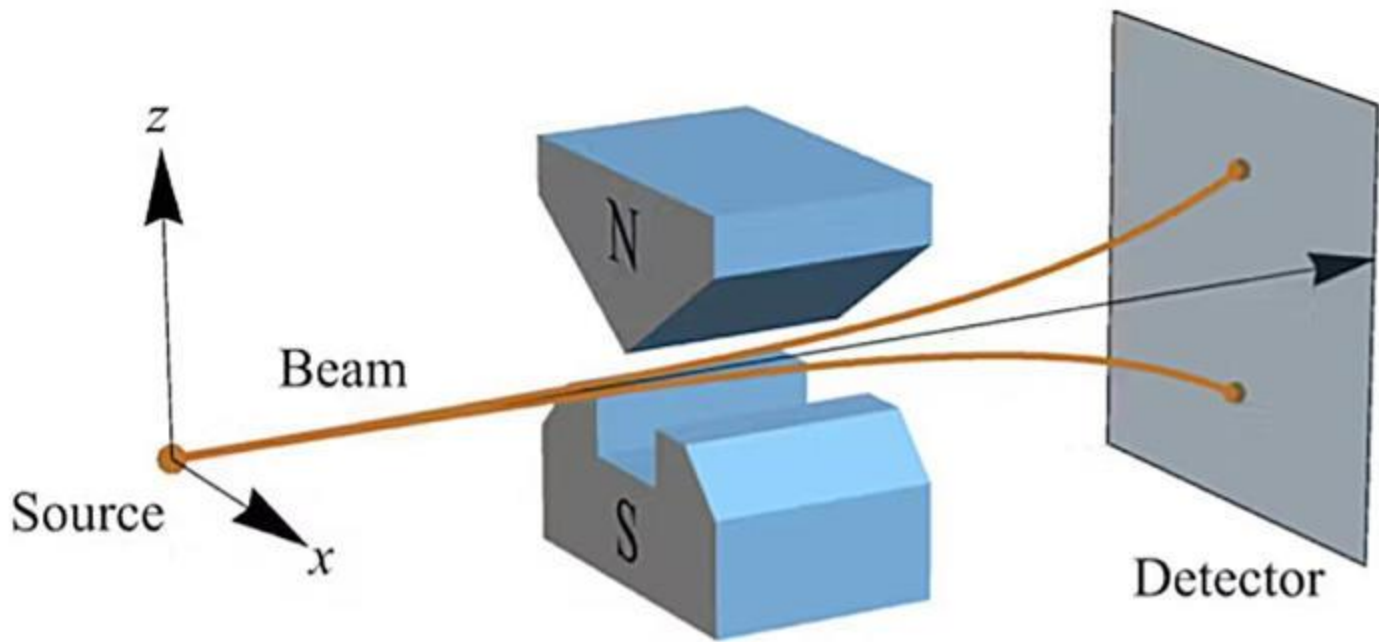

Measuring the spin of a beam of electrons vertically.

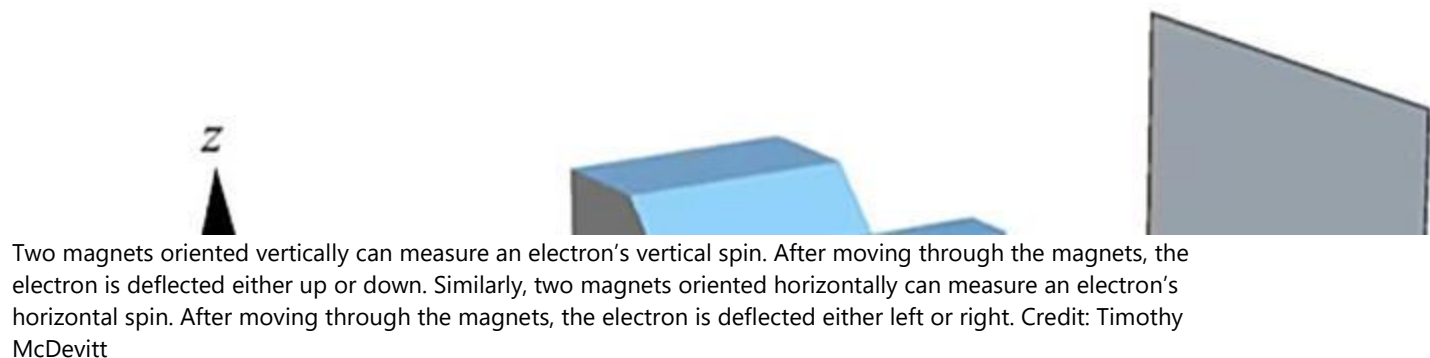

Two magnets oriented vertically can measure an electron's vertical spin. After moving through the magnets, the electron is deflected either up or down. Similarly, two magnets oriented horizontally can measure an electron's horizontal spin. After moving through the magnets, the electron is deflected either left or right. Credit: Timothy McDevitt

The year 2025 marks the 100th anniversary of the birth of [quantum mechanics](#). In the century since the field's inception, scientists and engineers have used quantum mechanics to create technologies such as lasers, MRI scanners and computer chips.

Today, researchers are looking toward building quantum computers and ways to securely transfer information using an entirely new sister field called [quantum information science](#).

But despite creating all these breakthrough technologies, physicists and philosophers who study quantum mechanics still haven't come up with the answers to some big questions raised by the field's founders. Given recent developments in quantum information science, [researchers like me](#) are using quantum information theory to explore new ways of thinking about these unanswered foundational questions. And one direction we're looking into relates Albert Einstein's relativity principle to the qubit.

Quantum computers

Quantum information science focuses on building quantum computers based on the [quantum "bit" of information, or qubit](#). The qubit is historically grounded in the discoveries of physicists [Max Planck](#) and [Einstein](#). They [instigated the development](#) of quantum mechanics in 1900 and 1905, respectively, when they discovered that light exists in discrete, or "quantum," bundles of energy.

[These quanta of energy](#) also come in small forms of matter, such as atoms and electrons, which make up everything in the universe. It is the odd properties of these tiny packets of matter and energy that are responsible for the computational advantages of the qubit.

A computer based on a quantum bit rather than a classical bit could have a significant computing advantage. And that's because a classical bit produces a binary response—either a 1 or a 0—to only one query.

In contrast, the qubit produces a binary response to infinitely many queries using the property of quantum superposition. This property allows researchers to connect multiple qubits in what's called a quantum entangled state. Here, the entangled qubits act collectively in a way that arrays of classical bits cannot.

That means a quantum computer can do some calculations much faster than an ordinary computer. For example, one device reportedly used 76 entangled qubits to solve a sampling problem [100 trillion times faster](#) than a classical computer.

But the exact force or principle of nature responsible for this quantum entangled state that underlies quantum computing is a big unanswered question. A solution

that my colleagues and I in quantum information theory have proposed has to do with [Einstein's relativity principle](#).

Quantum information theory

The relativity principle says that the laws of physics are the same for all observers, regardless of where they are in space, how they're oriented or how they're moving relative to each other. [My team showed how](#) to use the relativity principle in conjunction with the principles of quantum information theory [to account for quantum entangled particles](#).

Quantum information theorists like me think about quantum mechanics as a theory of information principles rather than a theory of forces. That's very different than the typical approach to quantum physics, in which force and energy are important concepts for doing the calculations. In contrast, quantum information theorists don't need to know what sort of physical force might be causing the mysterious behavior of entangled quantum particles.

That gives us an advantage for explaining quantum entanglement because, as physicist [John Bell proved in 1964](#), any explanation for quantum entanglement in terms of forces requires what Einstein called "spooky actions at a distance."

That's because the measurement outcomes of the two entangled quantum particles are correlated—even if those measurements are done at the same time and the particles are physically separated by a vast distance. So, if a force is causing quantum entanglement, it would have to act faster than the speed of light. And a faster-than-light force violates Einstein's [theory of special relativity](#).

Many researchers are trying to find an explanation for quantum entanglement that doesn't require spooky actions at a distance, like my team's proposed solution.

Classical and quantum entanglement

In entanglement, you can know something about two particles collectively—call them particle 1 and particle 2—so that when you measure particle 1, you immediately know something about particle 2.

Imagine you're mailing two friends, whom physicists typically call Alice and Bob, each one glove from the same pair of gloves. When Alice opens her box and sees a left-hand glove, she'll know immediately that when Bob opens the other box he will see the right-hand glove. Each box and glove combination produces one of two outcomes, either a right-hand glove or a left-hand glove. There's only one possible measurement—opening the box—so Alice and Bob have entangled classical bits of information.

But in quantum entanglement the situation involves entangled qubits, which behave very differently than classical bits.

Qubit behavior

Consider a property of electrons called spin. When you measure an electron's spin using magnets that are oriented vertically, you always get a spin that's up or down, nothing in between. That's a binary measurement outcome, so this is a bit of information.

If you turn the magnets on their sides to measure an electron's spin horizontally, you always get a spin that's left or right, nothing in between. The vertical and horizontal orientations of the magnets constitute two different measurements of this same bit. So, electron spin is a qubit—it produces a binary response to multiple measurements.

Quantum superposition

Now suppose you first measure an electron's spin vertically and find it is up, then you measure its spin horizontally. When you stand straight up, you don't move to

your right or your left at all. So, if I measure how much you move side to side as you stand straight up, I'll get zero.

That's exactly what you might expect for the vertical spin up electrons. Since they have vertically oriented spin up, analogous to standing straight up, they should not have any spin left or right horizontally, analogous to moving side to side.

Surprisingly, [physicists have found](#) that half of them are horizontally right and half are horizontally left. Now it doesn't seem to make sense that a vertical spin up electron has left spin (-1) and right spin (+1) outcomes when measured horizontally, just as we expect no side-to-side movement when standing straight up.

But when you add up all the left (-1) and right (+1) spin outcomes you do get zero, as we expected in the horizontal direction when our spin state is vertical spin up. So, on average, it's like having no side-to-side or horizontal movement when we stand straight up.

This 50–50 ratio over the binary (+1 and -1) outcomes is what physicists are talking about when they say that a vertical spin up electron is in a quantum superposition of horizontal spins left and right.

Entanglement from the relativity principle

According to quantum information theory, all of quantum mechanics, to include its quantum entangled states, is based on the qubit with its quantum superposition.

What my colleagues and I proposed is that this quantum superposition results from [the relativity principle](#), which (again) states the laws of physics are the same for all observers with different orientations in space.

If the electron with a vertical spin in the up direction were to pass straight through the horizontal magnets as you might expect, it would have no spin horizontally. This would violate the relativity principle, which says [the particle should have a spin](#) regardless of whether it's being measured in the horizontal or vertical direction.

Because an electron with a vertical spin in the up direction does have a spin when measured horizontally, quantum information theorists can say that [the relativity principle is \(ultimately\) responsible for quantum entanglement](#).

And since there is no force used in this principle explanation, there are none of the "spooky actions at a distance" that Einstein derided.

With quantum entanglement's technological implications for quantum computing firmly established, it's nice to know that one big question about its origin may be answered with a highly regarded physics principle.

By Karmela Padavic-Callaghan

Polarised light can make messages encoded in a quantum hologram disappear Hong Liang, Wai Chun Wong, Tailin An, Jensen Li 2024

A quantum disappearing act could make it possible to embed secure messages in holograms and selectively erase parts of them even after they have been sent.

Quantum light signals are inherently secure information carriers, as intercepting their messages destroys fragile quantum states that encode them. To take advantage of this without having to use bulky devices, [Jensen Li](#) at the University of Exeter in the UK and his colleagues used a [metasurface](#), a 2D material engineered to have special properties, to create quantum holograms.

Read more

Quantum time travel: The experiment to 'send a particle into the past'

Holograms encode complex information that can be recovered when illuminated – for instance, a 2D holographic paper card reveals 3D images when light falls on it at the right angle. To make a quantum hologram, the researchers encoded information into a quantum state of a particle of light, or photon.

First, they used a laser to make a special crystal emit two photons that were inextricably linked through quantum entanglement. The photons travelled on separate paths, with only one encountering the metasurface along the way.

Thousands of tiny components on the metasurface, like nano-sized ridges, changed the photon's quantum state in a pre-programmed way, encoding a holographic image into it.

The partner photon encountered a polarised filter, which controlled which parts of the hologram were revealed – and which disappeared. The first photon's state was a superposition of holograms, so it simultaneously contained many possible variations of the message. Because the photons were entangled, polarising the second one affected the image the other created when hitting a camera. For instance, the test hologram contained the letters H, D, V and A, but adding a filter for horizontally polarised light erased the letter H from the final image.

Related video: Movie Holograms VS. Real Life Holograms | Futureproof with Michael Swaim (Dailymotion)

Li says the metasurface could be used to encode more complicated information into the photons, for example as part of a quantum cryptography protocol. He presented the work at the [SPIE Optics + Photonics conference](#) in San Diego, California, on 21 August.

“Everybody's dream is to see all this quantum technology that spreads out over many square metres on a table to be compact enough to sit in your smartphone. Metasurfaces seem to be a good way to go [about that],” says [Andrew Forbes](#) at the University of the Witwatersrand in South Africa. Quantum holograms like those in the new experiment could also be used for imaging tiny biological structures in medicine, which is a rapidly expanding field, he says.

A team led by researchers from the California NanoSystems Institute at UCLA has designed a unique material based on a conventional superconductor—that is, a substance that enables electrons to travel through it with zero resistance under certain conditions, such as extremely low temperature. The experimental material showed properties signaling its potential for use in quantum computing,

a developing technology with capabilities beyond those of classical digital computers.

The paper is [published](#) in the journal *Nature*.

Conventional superconductors usually fail under magnetic fields of a certain strength. The new material continued to retain superconducting properties under a much higher magnetic field than the theoretical limit of a conventional superconductor. The team also measured how large an electrical current the new material can accommodate before it breaks superconductivity, applying electricity from one direction and then again from the opposite direction. The researchers found that one direction allowed notably higher current than the other. This is often referred to as the superconducting diode effect. In contrast, conventional superconductors would lose their zero-resistance property at equal current from either direction.

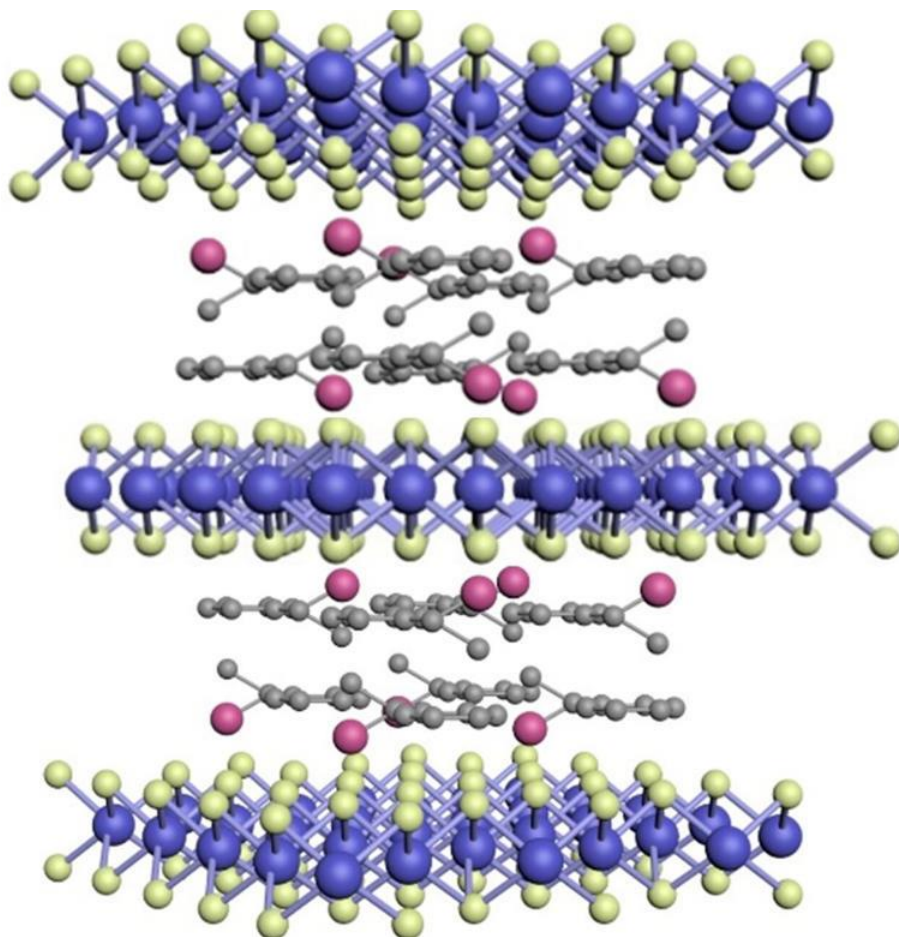

Illustration of a lattice with alternating layers created by a UCLA-led team of researchers. Credit: Duan Research Group/UCLA

Quantum computers operate based on the counterintuitive rules that govern how subatomic particles interact. The basic unit of information in quantum computing, the qubit, can have a multitude of values. Meanwhile, the bit—the basic unit of information in classical computing—can only have one of two values.

While quantum computers could perform calculations that traditional computers cannot, the technology is still in its early days, with obstacles left to overcome before realizing its promise. One such obstacle is the fragility of the qubit. Minor changes in conditions can cause qubits to lose their quantum properties, which last only millionths of a second.

Researchers have theorized that an unconventional type of superconductor, called a chiral superconductor, may help increase qubits' ability to maintain accuracy while performing a program's steps.

Both chiral and conventional superconductors depend on quantum phenomena. Pairs of electrons become linked at a distance in a state known as entanglement, which imposes certain rules upon the properties of the electrons. In conventional superconductors, to abide by these rules, entangled electrons move in opposite directions and spin in opposite directions. In chiral superconductors, entangled electrons could spin in the same direction, and they have to abide by rules that make the relationship between their motion extremely complex, potentially opening new possibilities for tailoring the flow of current or processing information.

As an upshot of this contrast, the activity of electrons in conventional superconductors display symmetries that are broken in chiral superconductors, which favor flow in one direction over the other, as seen in the superconducting diode effect. Today, only a few compounds are candidates for chiral superconductivity, and they are extremely rare. In the current study, the researchers found a way to customize their material to coax a conventional superconductor to act like a chiral one.

The UCLA-led team created a lattice with alternating layers. One layer made of tantalum disulfide, a conventional superconductor, was as thin as three atoms. The next was made of a "left-handed" or "right-handed" molecular layer of a different compound. The investigators tested tiny nanoscale devices made from their lattice to evaluate whether the material showed the properties of a chiral superconductor.

Quantum computing may yield innovations such as unbreakable cybersecurity, supercharged artificial intelligence and high-fidelity simulations of phenomena, from the action of drugs in the body to the flow of city traffic to the fluctuations of financial markets. To get to those applications, quantum computers will need to make leaps in their ability to function despite potential disturbances to fragile qubits. Superconducting circuits are foundational to many quantum computing approaches, and the superconducting diode effect achieved by chiral superconductors is expected to be useful for creating more efficient and stable qubits.

In addition to its utility for quantum computing, chiral superconductors' superconducting diode effect could make conventional electronics and communication technologies operate much faster while minimizing energy consumption. These qualities are particularly well suited for specialized applications such as computers working at extremely low temperatures in deep space.

Because chiral superconductors have been so difficult to find, engineering them from more readily available ingredients—such as in the new hybrid material reported in this study—could help unlock quantum computing's potential while also driving improvements to electronic devices.



'Unbreakable' quantum communication closer to reality thanks to new, exceptionally bright photons© Pitris/Getty Images

Scientists have created an "exceptionally bright" light source that can generate quantum-entangled photons (particles of light) which could be used to securely transmit data in a future high-speed quantum communications network.

A future quantum internet could transmit information using pairs of [entangled photons](#) — meaning the particles share information over time and space regardless of distance. Based on the weird laws of [quantum mechanics](#), information encoded into these entangled photons can be transferred at high speeds while their "quantum coherence" — a state in which the particles are entangled — ensures the data cannot be intercepted.

But one of the key challenges in building a quantum internet has been that the strength of these photons can fade the further they travel; the light sources have

not been bright enough. To build a successful quantum internet that can send data over vast distances, photons must be strong enough to prevent "decoherence" — where entanglement is lost and the information they contain disappears.

In research published 24 July in the journal [eLight](#), scientists from Europe, Asia and South America created a new type of quantum signal source using existing technologies that achieves extremely high brightness.

Related: [Quantum data beamed alongside 'classical data' in the same fiber-optic connection for the 1st time](#)

They achieved this by combining a photon dot emitter (a generator of single photons, or a particle of light) with a quantum resonator (a device to strengthen the quantum signature) to create the powerful new quantum signal.

What makes the recent research especially interesting is that the individual technologies have been independently proven in laboratories, but they had only been tested separately. This study is the first time they have been used in conjunction with each other.

Researchers combined the photon dot emitter with a circular Bragg resonator (a reflector used to guide electromagnetic waves) on a piezoelectric actuator (a device that generates electricity when heat or stress is applied). Together they created an enhanced form of photon emitter, which can fine-tune the emitted photons for maximum polarized entanglement. This was controlled by using the piezoelectric actuator.

Photon pairs generated by the device had a high entanglement fidelity and extraction efficiency — meaning that each photon is bright enough to be useful and holds its "quantum signature" (a useful quantum property) well. It was previously hard to achieve both a useful level of brightness and a high entanglement fidelity at the same time, because each aspect required a different technology and these were difficult to combine in a scalable manner.

This is a significant step forward in developing practical quantum technologies, demonstrating how they can be combined together to create a more powerful and viable light source.

Unfortunately, we should not expect a quantum internet any time soon, as the various technologies remain in the experimental and development phase. Making the photon emitter used in the study also required toxic raw materials, including arsenic, which required specialist handling. There are also safety concerns around the use of gallium arsenide, which the photon dot emitter was made from. [Fisher Scientific](#), a supplier of laboratory equipment and chemicals for scientific research, [lists](#) gallium arsenide as hazardous for several reasons, including its carcinogenic properties.

The safety concerns relating to the use of these materials could limit the scalability of the methodology outlined. Viable alternative materials may therefore need to be identified in generating bright, entangled photons for future quantum communications network

The next stage in the development process will be to integrate a diode-like structure onto the piezoelectric actuator. This would allow an electric field to be generated across the quantum dots, in order to counteract decoherence and therefore boost the degree of entanglement.

Although there are many further steps to take in developing a quantum internet, successfully combining a photon emitter and a resonator to achieve photons with high brightness and entanglement is nonetheless a significant step forward, the scientists said.

The National Institute of Standards and Technology (NIST) has [released](#) its first three encryption standards designed to withstand decryption efforts from a quantum computer.

Quantum computers will provide computing power millions of times faster than current supercomputers, with the ability to crack current encryption standards equally as fast.

As a result of this, cybercriminals are already attacking organizations and stealing their encrypted data with the intention of decrypting it when they are able to get

their hands on a quantum computer. This day is known among the security community as Q-Day.

Defending against Q-Day

Our current encryption standards are used to protect almost everything we do across the internet, but they are not enough to defend against quantum computers, which is why new encryption algorithms capable of withstanding an attack from a quantum computer are currently being developed to protect both against theft now, and cracking in the future.

Quantum computers are especially good at factoring, which can be used to crack encryption methods quickly. Experts predict that the first quantum computers could emerge within 10 years, but at this time they will likely only be operational for research and development purposes in the hands of their manufacturers, with it being several more years before commercially available quantum computers appear on the market.

Related video: Govt mulls quantum tech policy to bolster cyber resilience (Dailymotion)

NIST has been working to produce these three encryption standards for eight years, drawing the best and the brightest of the encryption community to its cause.

"The advancement of quantum computing plays an essential role in reaffirming America's status as a global technological powerhouse and driving the future of our economic security," commented US Deputy Secretary of Commerce, Don Graves.

"Commerce bureaus are doing their part to ensure U.S. competitiveness in quantum, including the National Institute of Standards and Technology, which is at the forefront of this whole-of-government effort. NIST is providing invaluable expertise to develop innovative solutions to our quantum challenges, including security measures like post-quantum cryptography that organizations can start to implement to secure our post-quantum future."

"As this decade-long endeavor continues, we look forward to continuing Commerce's legacy of leadership in this vital space," Graves concluded.

Included in the encryption standards are the algorithms' computer code, implementation instructions, and the intended uses for each form of encryption. The first, named Federal Information Processing Standard (FIPS) 203 is a general encryption standard based on the CRYSTALS-Kyber algorithm, renamed to Module-Lattice-Based Key-Encapsulation Mechanism (ML-KEM).

The second, FIPS 204, is designed to protect digital signatures by using the CRYSTALS-Dilithium algorithm - renamed Module-Lattice-Based Digital Signature Algorithm (ML-DSA). The last encryption standard, FIPS 205, is also designed for digital signatures, but utilizes a different standard to ML-DSA in case vulnerabilities are discovered in FIPS 204. FIPS 205 uses the Sphincs+ algorithm, renamed to Stateless Hash-Based Digital Signature Algorithm (SLH-DSA).

This is an updated version of a story first published on Dec. 3, 2023. The original video can be viewed [here](#).

Artificial intelligence is the magic of the moment but this is a story about what's next, something incomprehensible. This past December, IBM announced an advance in an entirely new kind of computing - one that may solve problems in minutes that would take today's supercomputers millions of years. That's the difference in quantum computing, a technology being developed at IBM, Google and others. It's named for quantum physics, which describes the forces of the subatomic realm. And as we told you last winter, the science is deep and we can't scratch the surface, but we hope to explain just enough so that you won't be blindsided by a breakthrough that could transform civilization.

The quantum computer pushes the limits of knowledge--new science, new engineering-- all leading to this processor that computes with the atomic forces that created the universe.

Dario Gil: I think this moment, it feels to us like the pioneers of the 1940s and 50s that were building the first digital computers.

Dario Gil is something of a quantum crusader. Spanish-born with a Ph.D. in electrical engineering, Gil is head of research at IBM.

Scott Pelley: How much faster is this than say, the world's best supercomputer today?

Dario Gil: We are now in a stage where we can do certain calculations with these systems that would take the biggest supercomputers in the world to be able to do some similar calculation. But the beauty of it, is that we see that we're gonna continue to expand that capability, such that not even a million or a billion of those supercomputers connected together could do the calculations of these future machines. So, we've come a long way. And the most exciting part is that we have a road map and a journey right now, where that is going to continue to increase at a rate that is gonna be shocking.

Scott Pelley: I'm not sure the world is prepared for this change.

Dario Gil: Definitely not.

To *understand* the change, go back to 1947 and the invention of a switch called a transistor.

Computers have processed information on transistors ever since, getting faster as more transistors were squeezed onto a chip--billions of them today.

But it takes *that* many because each transistor holds information in only two states. It's either on or it's off-- like a coin-- heads or tails. Quantum abandons transistors and encodes information on electrons that behave like *this* coin we created with animation. Electrons behave in a way so that they are heads *and* tails and everything in between. You've gone from handling one bit of information at a time on a transistor to exponentially more data.

Michio Kaku: You can see that there's a fantastic amount of information stored, when you can look at all possible angles, not just up or down.

Physicist Michio Kaku of the City University of New York, already calls today's computers "classical." He uses a maze to explain quantum's difference.

Michio Kaku: Let's look at a classical computer calculating how a mouse navigates a maze. It is painful. One by one, it has to map every single left turn, right turn, left turn, right turn before it finds the goal. Now a quantum computer scans all possible routes simultaneously. This is amazing. How many turns are there? Hundreds of possible turns, right? Quantum computers do it all at once.

Kaku's book, titled "Quantum Supremacy," explains the stakes.

Michio Kaku: We're looking at a race, a race between China, between IBM, Google, Microsoft, Honeywell, all the big boys are in this race to create a workable, operationally efficient quantum computer. Because the nation or company that does this, will rule the world economy.



Physicist Michio Kaku / Credit: 60 Minutes© Provided by CBS News

But a reliable, general purpose, quantum computer is a tough climb yet. Maybe that's why this wall is in the lobby of Google's quantum lab in California.

Here, we got an inside look, starting with a microscope's view of what replaces the transistor.

Google employee: This right here is one qubit and this is another qubit, this is a five qubit chain.

Those crosses, at the bottom, are qubits, short for quantum bits. They hold the electrons and act like artificial atoms. Unlike transistors, each additional qubit doubles the computer's power. It's exponential. so, while 20 transistors are 20

times more powerful than one. Twenty qubits are a million times more powerful than one.

Charina Chou: So this gets positioned right here on the fridge.

Charina Chou, chief operating officer of Google's lab, showed us the processor that holds the qubits. Much of that above chills the qubits to what physicists call near absolute zero.

Scott Pelley: Near absolute zero I understand is about 460 degrees below zero Fahrenheit. So that's about as cold as anything can get.

Charina Chou: Yes, almost as cold as possible.

That temperature, inside a sealed computer, is one of the coldest places in the universe. The deep freeze eliminates electrical resistance and isolates the qubits from outside vibrations so they can be controlled with an electro-magnetic field. The qubits must vibrate in unison. But that's a tough trick called coherence.

Scott Pelley: Once you have achieved coherence of the qubits, how easy is that to maintain?

Charina Chou: It's really hard. Coherence is very challenging.

Coherence is fleeting. In all similar machines, coherence breaks down constantly--creating errors.

Charina Chou: We're making about one error in every hundred or so steps. Ultimately, we think we're gonna need about one error in every million or so steps. That would probably be identified as one of the biggest barriers.



Charina Chou, chief operating officer at Google Quantum AI, and Scott Pelley / Credit: 60 Minutes© Provided by CBS News

Mitigating those errors and extending coherence time while scaling up to larger machines are the challenges facing German-American scientist Hartmut Neven, who founded Google's lab, and its casual style, in 2012.

Scott Pelley: Can the problems that are in the way of quantum computing be solved?

Hartmut Neven: I should confess, my subtitle here is chief optimist. After having said this, I would say at this point, we don't need any more fundamental breakthroughs. We need little improvements here and there. If we have all the pieces together, we just need to integrate them well to build larger and larger systems.

Scott Pelley: And you think that all of this will be integrated into a system in what period of time?

Hartmut Neven: Yeah. We often say we wanna do it by the end of the decade so that we can use this Kennedy quote, "Get it done by the end of the decade."

Scott Pelley: The end of this decade?

Hartmut Neven: Yes.

Scott Pelley: Five or six years?

Hartmut Neven: Yes.

That's about the timeline Dario Gil predicts. And the IBM research director told us something surprising.

Scott Pelley: There are problems that classical computers can never solve.

Dario Gil: Can never solve. And I think this is an important point because we're accustomed to say, "ah computers get better." Actually, there are many, many problems that are so complex that we can make that statement that, "Actually, classical computers will never be able to solve that problem." Not now, not 100 years from now, not 1,000 years from now." You actually require a different way to represent information and process information. That's what quantum gives you.

Quantum could give us answers to impossible problems in physics, chemistry, engineering and medicine. Which is why IBM and Cleveland Clinic have installed one of the first quantum computers to leave the lab for the real world.

Serpil Erzurum: It takes way too much time to find the solutions we need.

We sat down with Dario Gil and Dr. Serpil Erzurum, chief research officer at Cleveland Clinic. She told us health care would be transformed if quantum computers can model the behavior of proteins- the molecules that regulate all life. Proteins change shape to change function in ways too complex to follow. and when they get it wrong that causes disease.

Serpil Erzurum: It takes on many shapes, many, many shapes, depending upon what it's doing, and where it is, and which other protein it's with. I need to understand the shape it's in when it's doing an interaction or a function that I don't want it to do for that patient. Cancer, autoimmunity. It's a problem. We are limited completely by the computational ability to look at the structure in real time for any, even one, molecule.

Cleveland Clinic is so proud of its quantum computer they set it up in a lobby. Behind the glass, that shiny silver cylinder encloses the kind of cooling system and processor you saw earlier. Quantum is not solving the protein problem yet. This is more of a trial run to introduce researchers to quantum's potential.

Scott Pelley: The people using this machine, are they having to learn an entirely different way to communicate with a computer?

Dario Gil: I think that's what's really nice, that you actually just use a regular laptop, and you write a program very much like you would write a traditional program. But when you, you know, click, you know, "go" and "run," it just happens to run on a very different kind of computer.

There are a half dozen competing designs in the race. China named quantum a top national priority and the U.S. government is spending nearly a billion dollars a year on research. The first change is expected to come this year when the U.S. publishes new standards for encryption because quantum is expected one day to break the codes that lock everything from national secrets to credit cards. This past December IBM unveiled its Quantum System Two with three times the qubits as the machine you saw in Cleveland. Last year we saw System Two under construction.

Dario Gil: It's a machine unlike anything we have ever built.

Scott Pelley: And this is it.

Dario Gil: And this is it.

IBM's Dario Gil told us System Two has the room to expand to thousands of qubits.

Scott Pelley: What are the chances that this is one of those things that's gonna be ready in five years and always will be?

Dario Gil: We don't see an obstacle right now that would prevent us from building systems that will have tens of thousands and even a 100 thousand qubits working with each other. So we are highly confident that we will get there.

Of all the amazing things we heard, it was physicist Michio Kaku who led us down the path to the biggest idea of all. He said we were walking through a quantum

computer. Processing information with subatomic particles is how the universe works.

Michio Kaku: You know when I look at the night sky, I see stars, I look at the flowers, the trees I realize that it's all quantum, the splendor of the universe itself. The language of the universe is the language of the quantum.

Learning that language may bring more than inconceivable speed. Reverse engineering nature's computer could be a window on creation itself.



Unraveling the quantum nature of gravity© Provided by Earth

Gravity, the force that keeps our feet on the ground and the planets in orbit, is an integral part of our daily lives. Despite its ubiquity, the true [nature of gravity](#) remains a mystery. Scientists are still grappling with the question of whether gravity is fundamentally a geometrical phenomenon, as proposed by Einstein, or if it is governed by the laws of [quantum mechanics](#).

In a study published in *Physical Review X*, researchers from Amsterdam and Ulm have proposed an innovative experiment that could shed light on this age-old question.

Ludovico Lami, a mathematical physicist at the [University of Amsterdam](#) and [QuSoft](#), and his colleagues have designed a new approach that circumvents the challenges faced by previous experimental proposals.

Quantum-gravity conundrum

The quest to unify quantum mechanics and gravitational physics is one of the most significant challenges in modern science. Progress in this field has been hindered by the inability to conduct experiments in regimes where both quantum and gravitational effects are relevant.

Related video: Gravitational Waves Create A 'Cosmic Symphony' That Scientists Are Tuning Into (Dailymotion)

As Nobel Prize laureate [Roger Penrose](#) once stated, we don't even know if a combined theory of gravity and quantum mechanics will require a "quantization of gravity" or a "granitization of quantum mechanics."

"The central question, initially posed by Richard Feynman in 1957, is to understand whether the gravitational field of a massive object can enter a so-called [quantum superposition](#), where it would be in several states at the same time," explains Lami.

"Prior to our work, the main idea to decide this question experimentally was to look for gravitationally induced entanglement – a way in which distant but related masses could share [quantum information](#). The existence of such entanglement would falsify the hypothesis that the gravitational field is purely local and classical," he continued.

Overcoming the delocalisation dilemma

The primary obstacle in previous experimental proposals has been the creation of distant but related massive objects, known as delocalised states.

The heaviest object for which quantum delocalisation has been observed to date is a large molecule, which is significantly lighter than the smallest source mass whose gravitational field has been detected. This discrepancy has pushed the hope of an experimental realization decades into the future.

Designing a novel experiment to beat the odds

Lami and his colleagues have proposed a potential solution to this deadlock. Their experiment aims to reveal the [quantumness of gravity](#) without generating any entanglement.

"Our team designed and investigate a class of experiments involving a system of massive 'harmonic oscillators' – for example, torsion pendula, essentially like the one that Cavendish used in his famous 1797 experiment to measure the strength of the gravitational force," Lami explains.

"We establish mathematically rigorous bounds on certain experimental signals for quantumness that a local [classical gravity](#) should not be able to overcome. We have carefully analysed the experimental requirements needed to implement our proposal in an actual experiments, and find that even though some degree of technological progress is still needed, such experiments could really be within reach soon."

Power of entanglement theory

Surprisingly, the researchers still rely on the mathematical machinery of entanglement theory in quantum information science to analyze their experiment, despite the absence of physical entanglement.

Lami clarifies, "The reason is that, although [entanglement](#) is not physically there, it is still there in spirit -- in a precise mathematical sense. It is enough that entanglement could have been generated."

New era of quantum gravity research

In summary, the study by Lami and his colleagues from Amsterdam and Ulm opens a new chapter in the quest to unravel the quantum nature of gravity.

Their innovative experimental proposal, which relies on the mathematical framework of entanglement theory without requiring physical entanglement, brings us closer to answering the fundamental question posed by Richard Feynman over six decades ago.

As technological progress continues to advance, the realization of this experiment becomes increasingly feasible, promising to shed light on one of the most profound mysteries in modern physics.

The implications of this research extend far beyond the realm of theoretical physics, as a deeper understanding of the quantum-gravity relationship could revolutionize our perception of the universe and our place within it.

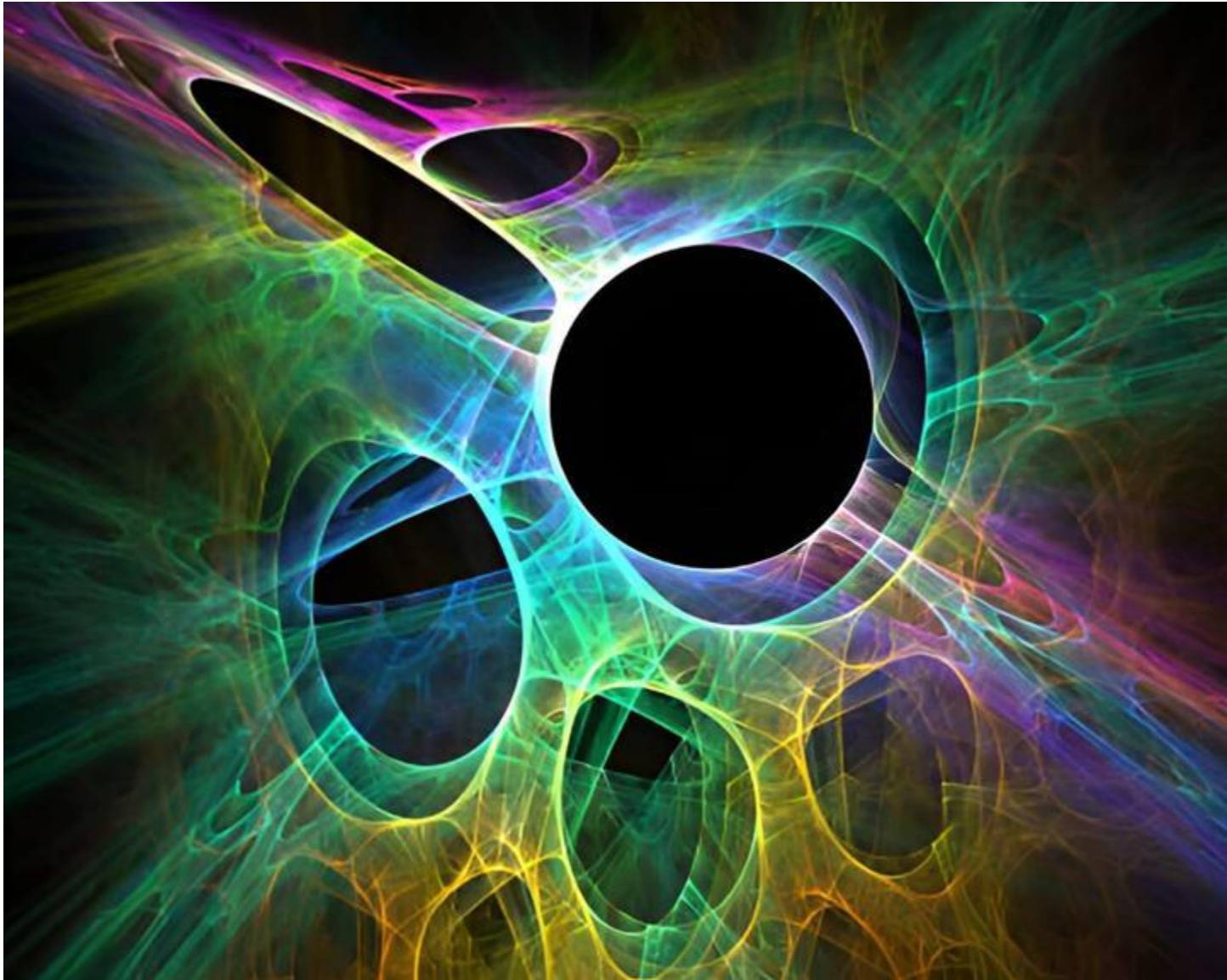

Superstrings may exist in 11 dimensions at once. Credit: National Institute of Technology Tiruchirappalli© Provided by Phys.org

String theory found its origins in an attempt to understand the nascent experiments revealing the strong nuclear force. Eventually another theory, one based on particles called quarks and force carriers called gluons, would supplant it, but in the deep mathematical bones of the young string theory physicists would find curious structures, half-glimpsed ghosts, that would point to something more. Something deeper.

String theory claims that what we call particles—the point-like entities that wander freely, interact, and bind together to make up the bulk of material existence—are nothing but. Instead, there is but a single kind of fundamental object: the string. These strings, each one existing at the smallest possible limit of existence itself, vibrate. And the way those strings vibrate dictates how they manifest themselves in the larger universe. Like notes on a strummed guitar, a string vibrating with one mode will appear to us as an electron, while another vibrating at a different frequency will appear as a photon, and so on.

String theory is an audacious attempt at a [theory of everything](#). A single mathematical framework that explains the particles that make us who and what we are along with the forces that act as the fundamental messengers among those particles. They are all, every quark in the cosmos and every photon in the field, bits of vibrating strings.

String theory remains the most promising avenue toward a quantum theory of gravity. It can claim this ultimate title because it incorporates all the forces of nature under its banner, potentiality fulfilling the unification dreams of the past half-millennium of physical exploration of the cosmos, and because the theory naturally includes a new particle (or rather, particular vibration of string) that has all the right properties to serve as the quantum force carrier of gravity, the gravitational analog to the photon.

String theory has not been tested, has not been verified, and is not yet even complete. Indeed, despite its enormous promise and potential, the mathematics that underpin the theory are so difficult to solve that nobody has yet come to a solution, let alone a prediction that can be predicted against experiment. It seems that nature is set to tease us again and again. The original attempts to fold gravity into a quantum framework collapse on themselves under the weight of irreducible infinities. And now the most promising solution around those infinities, to replace the point-like particles of old quantum theory with loops of strings, is so unworkable that the infinities sometimes seem preferable.

Despite its shortcomings, theorists have managed to make some headway into the deepening forests of the strings, and in their searching—which sometimes looks more like bold wishes that we hope someday may be proven true—they have struck on something unexpected.

Dimensionality plays a critical role in string theory. The tiny vibrating strings are tasked with the monumental effort of explaining all of creation—every kind of particle to ever have existed, to ever have been discovered, and all the more that we have yet to find. But early on string theorists discovered that the meager three dimensions of space were not enough; confined to our usual and familiar spacetime, strings cannot support enough different kinds of vibrations to explain the full panoply of particles.

And so string theorists came up with an elegant solution. If the universe does not have enough dimensions to give strings the freedom they need to explain all of physics, then we must add most dimensions to the universe. Modern versions of string theory state that we have either ten or eleven spatial dimensions (the difference comes from different formulations of the theory).

To explain why these extra dimensions have escaped our notice thus far in our experiences living in this universe, the dimensions in addition to the familiar three must be curled up on themselves to those same ultra-tiny scales as the strings themselves, shoving them into the hidden corners of perception and experiment. Even our ability to probe the constituents of atoms themselves is far too clumsy to pierce into this string-dominated realm.

We do not need to concern ourselves with the structure or properties of these hidden dimensions, because what matter to us is that string theory, which claims to be a successor in the unbroken chain of unification spanning five hundred years, and claims to one day blossom into a full theory of quantum gravity, admits the possibility, by very nature of mathematical necessity, that our universe has a different number of dimensions than what we may naively assume.

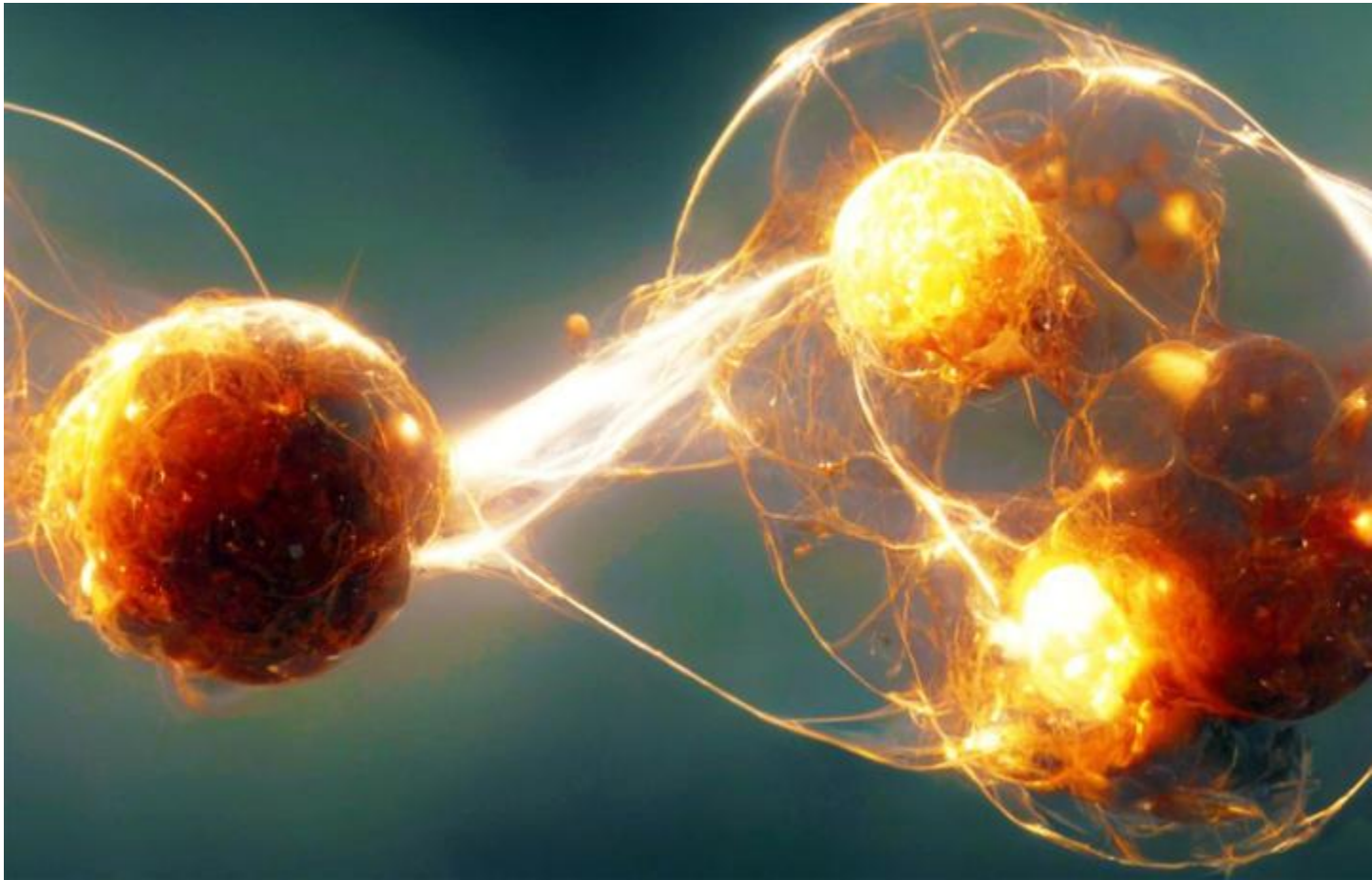

Elusive quantum ‘negative entanglement entropy’ deciphered in the lab

Quantum entanglement can be described as an almost magical link between particles that challenges our usual understanding of how things behave in reality.

This phenomenon shows that particles can become so intertwined that the state of one instantly affects the state of another, no matter how far apart they are.

Now, an exciting new study has expanded our grasp of this phenomenon by revealing something even more puzzling: negative entanglement entropy.

This finding suggests that under certain conditions, entangled particles can show a type of entanglement that really shakes up the traditional ideas of information and disorder in quantum systems.

This study, led by Dr. Xiangdong Zhang and his team of researchers from Singapore and China, promises to shift our understanding of quantum systems and their classical counterparts.

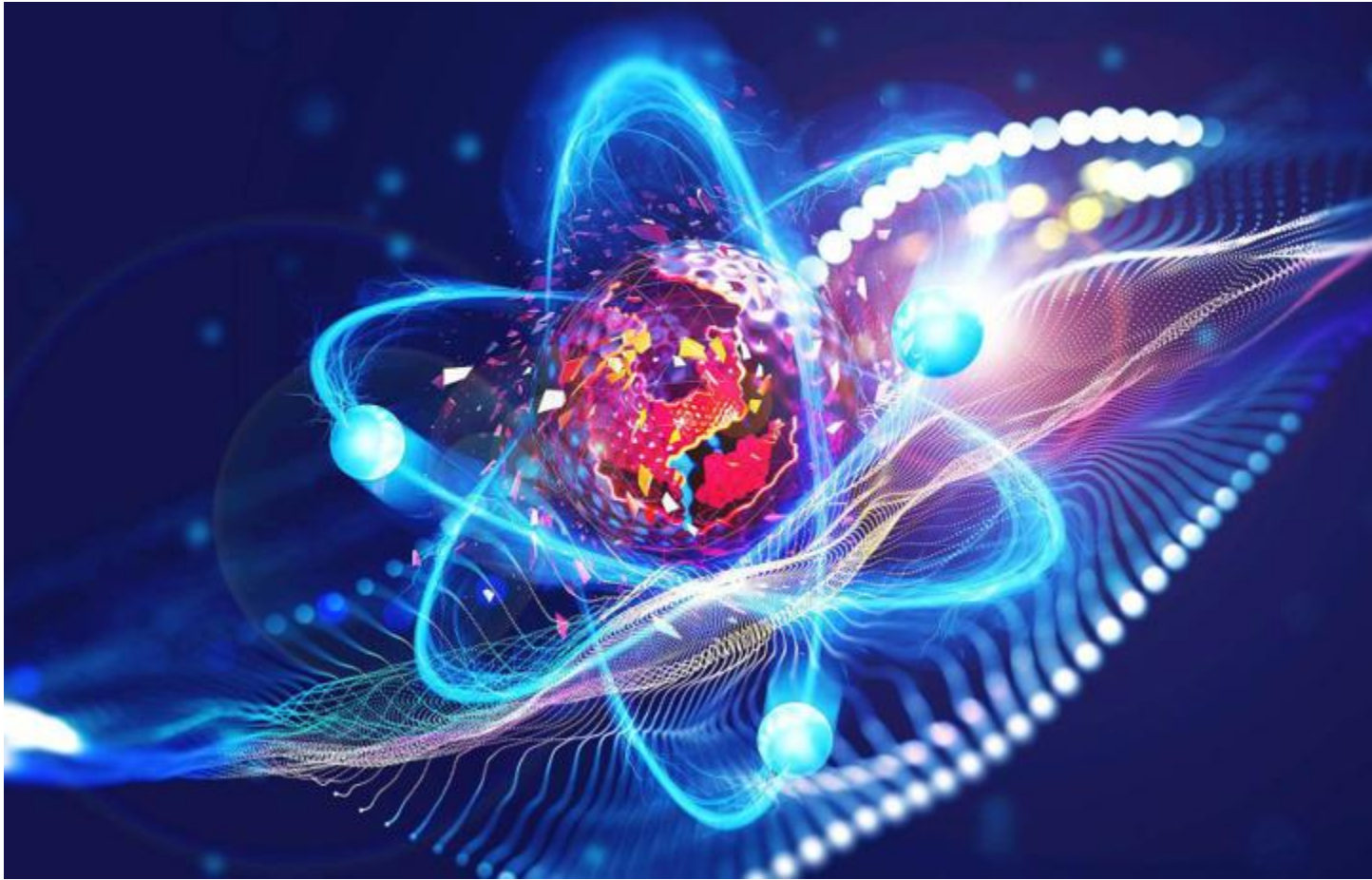

'Artificial atoms' are revolutionizing how we maintain privacy and protect data

In the world of digital data, and now quantum communication, security has always been a moving target, constantly evolving to meet new challenges.

As technology advances at an unprecedented pace, so do the threats that can compromise our confidential information, making it more crucial than ever to stay ahead of potential attacks.

The rise of [quantum computing](#) represents a significant leap in computational power, bringing us to a critical juncture where traditional encryption methods -- once deemed robust -- are increasingly vulnerable to decryption by these advanced systems.

This vulnerability raises serious concerns for businesses and individuals alike, as our reliance on digital platforms grows. But fear not -- quantum key distribution (QKD) is here to revolutionize the way we safeguard our data.

This cutting-edge technology leverages the principles of [quantum mechanics](#) to create secure communication channels, ensuring that our information remains protected in ways that were once unimaginable.

By using QKD, we can stay one step ahead of cyber threats and maintain the integrity of our most sensitive data.

Heart of quantum communication

Recently, an exciting experiment in Germany took quantum communication to new heights, representing a big step toward a secure quantum internet.

This achievement was led by Professor Fei Ding from [Leibniz University](#) of Hannover, Professor Stefan Kück from the Physikalisch-Technische Bundesanstalt ([PTB](#)), and Professor Peter Michler from the [University of Stuttgart](#), along with their brilliant team of researchers.

At the core of this experiment lies a fascinating piece of technology: semiconductor quantum dots (QDs). Often described as "artificial atoms," these tiny structures hold immense potential in the quantum world, particularly in the realm of [quantum information technologies](#).

50-mile long quantum internet

For the first time, these quantum dots were utilized in an intercity QKD experiment, connecting the cities of Hannover and Braunschweig via optical fiber in what has been dubbed the "[Niedersachsen Quantum Link](#)."

"We work with quantum dots, which are tiny structures similar to atoms but tailored to our needs. For the first time, we used these 'artificial atoms' in a

quantum communication experiment between two different cities," noted Professor Fei Ding, explaining the process.

This connection, stretching approximately 79 kilometers (50 miles), forms the first quantum communication link in Lower Saxony, Germany. It's a crucial step towards the realization of a secure, long-distance quantum internet.

Artificial atom (QKD) experiment

The experiment commenced with Alice at Leibniz University of Hannover (LUH), where she prepared [single photons encrypted](#) in polarization.

These photons were transmitted through a fiber-optic channel to Bob at the PTB in Braunschweig, whose role was to decrypt the polarized photons using a passive polarization decoder.

This innovative setup successfully illustrated the stable and rapid transmission of secret keys, a crucial element in secure communication.

Quantum communication breakthrough

In an impressive advancement, researchers have confirmed positive secret key rates (SKRs) over distances of up to 144 kilometers, corresponding to a 28.11 dB loss in a controlled laboratory setting.

Over 35 hours, they successfully accomplished high-rate secret key transmission while keeping the quantum bit error ratio (QBER) remarkably low.

Dr. Jingzhong Yang highlighted the importance of this development, noting, "When compared to existing quantum key distribution (QKD) systems that utilize single-photon sources (SPS), the SKR achieved in this study outperforms all current SPS-based implementations."

This significant success not only sets a new benchmark for QKD systems but also underscores the promising potential of [quantum dots in various](#)

[applications](#) within the emerging quantum internet. These include innovations such as quantum repeaters and distributed quantum sensing.

Why we need a quantum internet

The quest for secure communication is intrinsic to human civilization, with its importance magnified in today's digital landscape. As we navigate this era, the stakes have never been higher.

Enter quantum communication -- an incredible technological feat that harnesses the mind-bending [properties of quantum physics](#) to deliver unparalleled security.

By utilizing single photons emitted from quantum dot devices, we can transmit information across vast distances with a level of assurance that any interception attempt will be swiftly detected.

"Some years ago, we only dreamt of using quantum dots in real-world quantum communication scenarios," Professor Ding enthused.

"Today, we are thrilled to demonstrate their potential for many more fascinating experiments and applications in the future, moving towards a 'quantum internet'."

Road ahead for the quantum internet

The successful demonstration of intercity quantum key distribution using semiconductor quantum dots is a glimpse into the future of [secure communication](#).

As we move closer to realizing a quantum internet, the implications for cybersecurity, data privacy, and information sharing are profound.

This experiment lays the groundwork for more extensive and more complex quantum networks that could span entire continents. The integration of [quantum dots](#) into these networks is just the beginning.

Researchers speculate that quantum dots could also play a pivotal role in developing quantum repeaters, which are essential for extending the reach of quantum communication networks.

Quantum communication ushers in a new era

As we approach a [new era in communication](#), the work of Professor Ding and his colleagues exemplifies the remarkable potential of innovation and collaboration.

The quantum internet, once a distant aspiration, is now an emerging reality that stands to transform our methods of connection, communication, and the safeguarding of sensitive information.

While the journey to realize the quantum internet is ongoing, each advancement brings us closer to a future where secure communication is not merely a possibility but a certainty.

Though quantum dots may be small, their influence on the future of communication is poised to be profoundly significant.

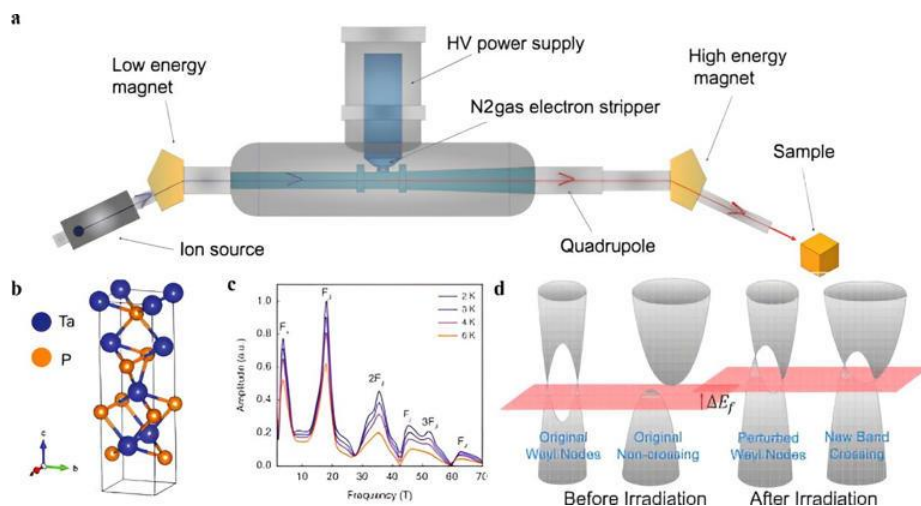

(a) Tandem accelerator schematic. (b) Crystal structure of the Weyl semimetal TaP. (c) Fast Fourier transform of the longitudinal magnetoresistance of TaP. (d) Illustration of the irradiation effect on the TaP's band structure. Credit: Applied Physics Reviews (2024). DOI: 10.1063/5.0181361

Quantum materials—those with electronic properties that are governed by the principles of quantum mechanics, such as correlation and entanglement—can

exhibit exotic behaviors under certain conditions, such as the ability to transmit electricity without resistance, known as superconductivity. However, in order to get the best performance out of these materials, they need to be properly tuned, in the same way that race cars require tuning as well.

A team led by Mingda Li, an associate professor in MIT's Department of Nuclear Science and Engineering (NSE), has demonstrated a new, ultra-precise way to tweak the characteristics of quantum materials, using a particular class of these materials, Weyl semimetals, as an example.

The new technique is not limited to Weyl semimetals. "We can use this method for any inorganic bulk material, and for thin films as well," maintains NSE postdoc Manasi Mandal, one of two lead authors of an open-access paper, [published](#) recently in *Applied Physics Reviews*, that reported on the group's findings.

The experiment described in the paper focused on a specific type of Weyl semimetal, a tantalum phosphide (TaP) crystal. Materials can be classified by their electrical properties: metals conduct electricity readily, whereas insulators impede the free flow of electrons. A semimetal lies somewhere in between. It can conduct electricity, but only in a narrow frequency band or channel.

Weyl semimetals are part of a wider category of so-called topological materials that have certain distinctive features. For instance, they possess curious electronic structures—kinks or "singularities" called Weyl nodes, which are swirling patterns around a single point (configured in either a clockwise or counterclockwise direction) that resemble hair whorls or, more generally, vortices.

The presence of Weyl nodes confers unusual, as well as useful, electrical properties. And a key advantage of topological materials is that their sought-after qualities can be preserved, or "topologically protected," even when the material is disturbed.

"That's a nice feature to have," explains Abhijatmedhi Chotrattanapituk, a Ph.D. student in MIT's Department of Electrical Engineering and Computer Science and the other lead author of the paper. "When you try to fabricate this kind of material, you don't have to be exact. You can tolerate some imperfections, some level of uncertainty, and the material will still behave as expected."

Like water in a dam

The "tuning" that needs to happen relates primarily to the Fermi level, which is the highest energy level occupied by electrons in a given physical system or material. Mandal and Chotrattanapituk suggest the following analogy: Consider a dam that can be filled with varying levels of water. One can raise that level by adding water or lower it by removing water. In the same way, one can adjust the Fermi level of a given material simply by adding or subtracting electrons.

To fine-tune the Fermi level of the Weyl semimetal, Li's team did something similar, but instead of adding actual electrons, they added negative hydrogen ions (each consisting of a proton and two electrons) to the sample. The process of introducing a foreign particle, or defect, into the TaP crystal—in this case by substituting a hydrogen ion for a tantalum atom—is called doping. And when optimal doping is achieved, the Fermi level will coincide with the energy level of the Weyl nodes. That's when the material's desired quantum properties will be most fully realized.

For Weyl semimetals, the Fermi level is especially sensitive to doping. Unless that level is set close to the Weyl nodes, the material's properties can diverge significantly from the ideal. The reason for this extreme sensitivity owes to the peculiar geometry of the Weyl node.

If one were to think of the Fermi level as the water level in a reservoir, the reservoir in a Weyl semimetal is not shaped like a cylinder; it's shaped like an hourglass, and the Weyl node is located at the narrowest point, or neck, of that hourglass. Adding too much or too little water would miss the neck entirely, just as adding too many or too few electrons to the semimetal would miss the node altogether.

Fire up the hydrogen

To reach the necessary precision, the researchers utilized MIT's two-stage "Tandem" ion accelerator—located at the Center for Science and Technology with Accelerators and Radiation (CSTAR)—and buffeted the TaP sample with high-

energy ions coming out of the powerful (1.7 million volt) accelerator beam. Hydrogen ions were chosen for this purpose because they are the smallest negative ions available and thus alter the material less than a much larger dopant would.

"The use of advanced accelerator techniques allows for greater precision than was ever before possible, setting the Fermi level to milli-electron volt [thousandths of an electron volt] accuracy," says Kevin Woller, the principal research scientist who leads the CSTAR lab. "Additionally, high-energy beams allow for the doping of bulk crystals beyond the limitations of thin films only a few tens of nanometers thick."

The procedure, in other words, involves bombarding the sample with hydrogen ions until a sufficient number of electrons are taken in to make the Fermi level just right. The question is: how long do you run the accelerator, and how do you know when enough is enough? The point being that you want to tune the material until the Fermi level is neither too low nor too high.

"The longer you run the machine, the higher the Fermi level gets," Chotrattanapituk says. "The difficulty is that we cannot measure the Fermi level while the sample is in the accelerator chamber."

The normal way to handle that would be to irradiate the sample for a certain amount of time, take it out, measure it, and then put it back in if the Fermi level is not high enough. "That can be practically impossible," Mandal adds.

To streamline the protocol, the team has devised a theoretical model that first predicts how many electrons are needed to increase the Fermi level to the preferred level and translates that to the number of negative hydrogen ions that must be added to the sample. The model can then tell them how long the sample ought to be kept in the accelerator chamber.

The good news, Chotrattanapituk says, is that their simple model agrees within a factor of 2 with trusted conventional models that are much more computationally intensive and may require access to a supercomputer.

The group's main contributions are two-fold, he notes: offering a new, accelerator-based technique for precision doping and providing a theoretical model that can guide the experiment, telling researchers how much hydrogen

should be added to the sample depending on the energy of the ion beam, the exposure time, and the size and thickness of the sample.

Fine things to come with fine-tuning

This could pave the way to a major practical advance, Mandal notes, because their approach can potentially bring the Fermi level of a sample to the requisite value in a matter of minutes—a task that, by conventional methods, has sometimes taken weeks without ever reaching the required degree of milli-eV precision.

Li believes that an accurate and convenient method for fine-tuning the Fermi level could have broad applicability. "When it comes to quantum materials, the Fermi level is practically everything," he says. "Many of the effects and behaviors that we seek only manifest themselves when the Fermi level is at the right location."

With a well-adjusted Fermi level, for example, one could raise the critical temperature at which materials become superconducting. Thermoelectric materials, which convert temperature differences into an electrical voltage, similarly become more efficient when the Fermi level is set just right. Precision tuning might also play a helpful role in quantum computing.

Thomas Zac Ward, a senior scientist at the Oak Ridge National Laboratory, offered a bullish assessment: "This work provides a new route for the experimental exploration of the critical, yet still poorly understood, behaviors of emerging materials. The ability to precisely control the Fermi level of a topological material is an important milestone that can help bring new quantum information and microelectronics device architectures to fruition."

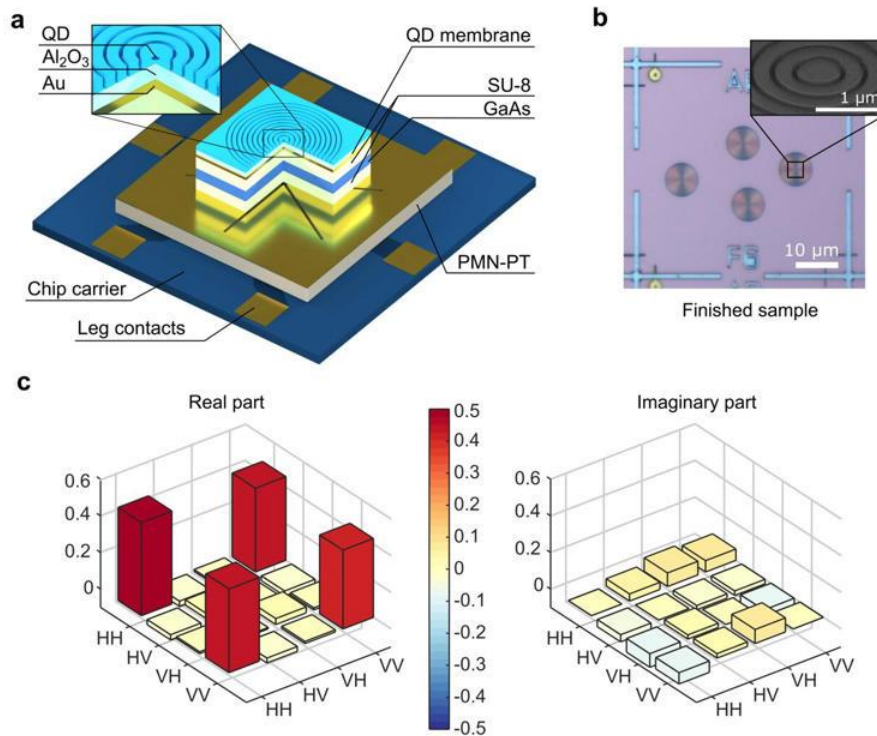

a. Schematic of a CBR sample on six-legged piezoelectric substrate mounted on a chip carrier. Dimensions are not to scale. b. Optical microscopy image of a finished sample. A tilted scanning electron microscope image of the centre of a single structure is shown in the inset. c. Reconstructed density matrix of the entangled-photon state emitted by the cavity enhanced quantum dot. Credit: eLight (2024). DOI: 10.1186/s43593-024-00072-8

Imagine the possibility of sending messages that are completely impervious to even the most powerful computers. This is the incredible promise of quantum communication, which harnesses the unique properties of light particles known as photons.

In quantum networks, information is encoded not only in the presence or absence of light pulses, but also in the intricate properties of the photons themselves, such as their polarization.

A pan-European, Asian, and South American research team has developed a new light source that emits exceptionally bright, entangled photons. These special pairs of photons are the cornerstone of quantum communication, a revolutionary technology that promises ultra-secure data transmission. Unlike traditional

sources, this new device overcomes limitations by achieving high brightness and entanglement, paving the way for more efficient and secure quantum networks.

A light source that can generate entangled photons is crucial for quantum communication. Entanglement is a bizarre quantum phenomenon where two photons become linked, sharing the same fate regardless of distance. If someone measures the property of one entangled photon, the other instantly reflects that change, even if they're separated by vast distances. This inherent link forms the basis for unbreakable encryption in quantum communication.

However, existing sources for entangled photons often face limitations. Traditional methods, like spontaneous parametric down-conversion (SPDC), can generate high-quality entangled photons but struggle with brightness. This means fewer entangled photons are available for communication, slowing data transfer.

Quantum emitters driven under resonant excitation offer a solution. These emitters can generate photons on demand and have the potential to be much brighter. Among these, semiconductor quantum dots (QDs) are particularly promising. However, until now, scientists haven't been able to optimize both brightness and entanglement in QD sources. They often had to choose between one or the other.

This new research, [published](#) in *eLight*, addresses this challenge. The scientists created a unique device integrating a quantum dot with a special light-trapping cavity and a micromachined platform. This allows them to precisely control the properties of the light emitted by the quantum dot. By fine-tuning these properties, they achieved a breakthrough—a source that simultaneously generates bright, entangled photons.

This new source represents a significant step towards practical applications of quantum communication. Generating bright, entangled photons on-demand is essential for building secure and efficient quantum networks. These networks could revolutionize various fields, from ultra-secure communication for governments and financial institutions to unbreakable encryption for everyday transactions.

While challenges remain in achieving even higher brightness and perfect indistinguishability of the entangled photons, this research marks a significant

leap forward. It demonstrates the potential of quantum dots as a reliable source for building the future of quantum communication networks.

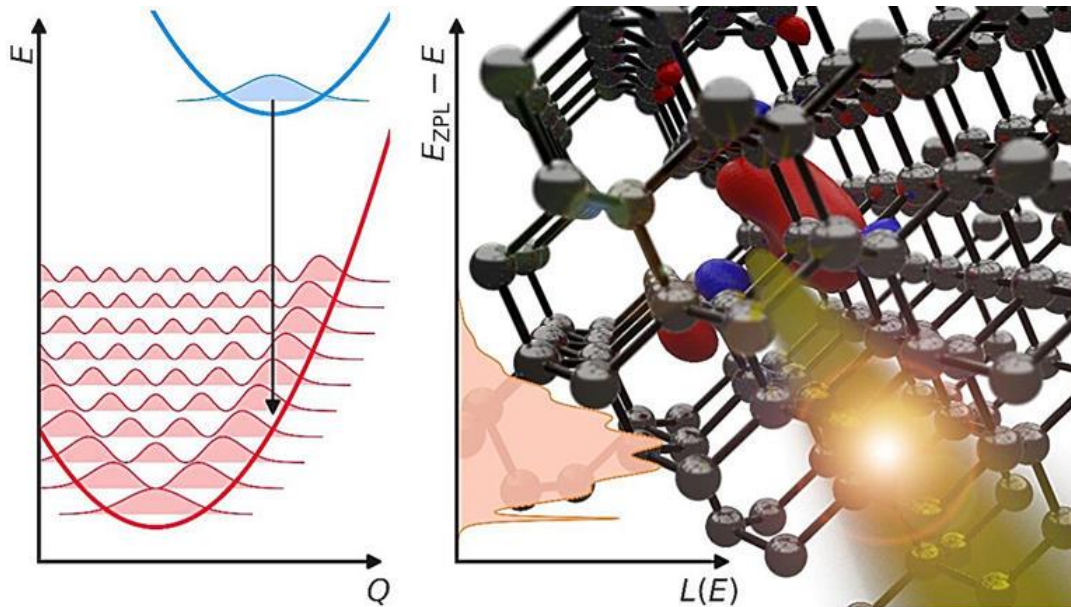

Concept illustration depicting a quantum defect emitting a single photon. Credit: Mark Turiansky© Provided by Phys.org

Computers benefit greatly from being connected to the internet, so we might ask: What good is a quantum computer without a quantum internet?

The secret to our modern internet is the ability for data to remain intact while traveling over long distances, and the best way to achieve that is by using photons.

Photons are single units ("quanta") of light. Unlike other quantum particles, photons interact very weakly with their environment. That stability also makes them extremely appealing for carrying quantum information over long distances, a process that requires maintaining a delicate state of entanglement for an extended period of time. Such photons can be generated in a variety of ways.

One possible method involves using atomic-scale imperfections (quantum defects) in crystals to generate single photons in a well-defined quantum state.

Decades of optimization have resulted in fiber-optic cables that can transmit photons with extremely low loss. However, this low-loss transmission works only for light in a narrow range of wavelengths, known as the "telecom wavelength band."

Identifying quantum defects that produce photons at these wavelengths has proven difficult. Researchers at the UC Santa Barbara College of Engineering conducted research to understand why that is and describe their findings in "[Rational Design of Efficient Defect-Based Quantum Emitters](#)," published in the journal *APL Photonics*.

"Atoms are constantly vibrating, and those vibrations can drain energy from a light emitter," says UCSB materials professor Chris Van de Walle. "As a result, rather than emitting a photon, a defect might instead cause the atoms to vibrate, reducing the light-emission efficiency."

Van de Walle's group developed theoretical models to capture the role of atomic vibrations in the photon-emission process and studied the role of various defect properties in determining the degree of efficiency.

Their work explains why the efficiency of single-photon emission drastically decreases when the emission wavelength increases beyond the wavelengths of visible light (violet to red) to the infrared wavelengths in the telecom band. The model also allows the researchers to identify techniques for engineering emitters that are brighter and more efficient.

"Choosing the host material carefully, and conducting atomic-level engineering of the vibrational properties are two promising ways to overcome low efficiency," said Mark Turiansky, a postdoctoral researcher in the Van de Walle lab, a fellow at the NSF UC Santa Barbara Quantum Foundry, and the lead researcher on the project.

Another solution involves coupling to a photonic cavity, an approach that benefited from the expertise of two other Quantum Foundry affiliates: computer engineering professor Galan Moody and Kamyar Parto, a graduate student in the Moody lab.

The team hopes that their model and the insights it provides will prove useful in designing novel quantum emitters that will power the quantum networks of the future.



Quantum solution discovered for the gravitational wave mystery

The merger of two black holes embodies a complex interplay of gravitational forces that twist, twirl, and ultimately collide, generating ripples and waves that resonate throughout the cosmos.

These ripples, known as gravitational waves, are subtle distortions so refined that detecting them necessitates extraordinary precision.

Since 2015, we have made significant strides in capturing these faint cosmic echoes, facilitated by the Laser Interferometer Gravitational-Wave Observatory ([LIGO](#)). However, we now stand on the brink of a transformative advancement that promises to bring cosmic phenomena into the confines of a laboratory.

Enter [Professor Nic Shannon](#), the head of the Theory of Quantum Matter Unit at the Okinawa Institute for Science and Technology ([OIST](#)). He leads an exceptional

team that has successfully replicated the behavior of these gravitational waves using cold atoms within a quantum condensate.

This innovative approach opens up a new frontier for exploring these elusive ripples in a controlled experimental environment.

Quantum particles and gravitational waves

Albert Einstein predicted the existence of gravitational waves in his [theory of general relativity](#). These cosmic ripples transport vital information about their sources and the fabric of space-time itself. Imagine tuning into a cosmic symphony, with gravitational waves playing the keynotes.

Related video: Gravitational Waves Create A 'Cosmic Symphony' That Scientists Are Tuning Into (Dailymotion)

That said, turning up the volume on this cosmic symphony is a formidable task. Only the mightiest of cosmic events -- [black hole mergers](#), supernovae explosions -- can produce gravitational waves intense enough for our present detectors, like LIGO in the U.S. and the Virgo interferometer in Europe, to capture.

Professor Shannon, senior author of the study and head of the unit, explains that Einstein's theory of general relativity revolutionized our understanding of [space and time](#).

"It taught us that space can bend to form a black hole and that it can vibrate, creating waves that travel across the universe at the speed of light," he says.

These gravitational waves hold crucial information about our universe, but they are extremely difficult to detect.

Gravitational waves and BEC

Professor Shannon and his team are taking a fresh approach, revisiting Earth-based phenomena that echo aspects of general relativity. They've introduced a novel way to examine gravitational waves without needing gigantic telescopes.

Their research, carried out with scholars from the [University of Tohoku](#) and the [University of Tokyo](#), hinges on a quantum phenomenon involving ultracold atoms -- [Bose-Einstein Condensate \(BEC\)](#).

When the temperature of bosons, a type of quantum particle, is reduced to nearly absolute zero, they behave as a single quantum entity. This collective conduct paves the way for researchers to [reproduce the conditions](#) that spawn gravitational waves.

Professor Han Yan from the University of Tokyo articulates why this novel approach matters, saying, "This result is important because it makes it possible to simulate and study gravitational waves in a much simpler experimental setting."

Creating a spin-nematic state

At OIST, the research team is delving into a fascinating type of Bose-Einstein condensate ([BEC](#)) known as spin nematics. In this captivating spin-nematic state, quantum particles display unique behaviors that enable them to transmit energy throughout the system.

How do they accomplish this? By generating waves that strikingly resemble gravitational waves.

"We realized that the properties of the waves in the spin-nematic state are mathematically identical to those of gravitational waves," explained Professor Shannon.

These waves not only facilitate energy transfer but also pave the way for deeper understanding of [quantum mechanics](#) and its potential applications in cutting-edge technologies.

The study of spin nematics holds the promise of uncovering insights into quantum phase transitions and the fundamental nature of matter, particularly at low temperatures.

Quantum physics and gravitational waves

Bridging the study of gravitational waves and the [quantum physics of cold atoms](#) has led to new possibilities.

Dr. Leilee Chojnacki, a lead author of the study, describes this as an opportunity to unite different branches of physics in a novel way.

She says, "It was very exciting for me to work on two very different branches of physics and bring them together in a way that hadn't previously been explored."

The ability to simulate gravitational waves in a laboratory ushers in a brand-new era. This method presents an opportunity to conduct experiments impossible with traditional gravitational wave detectors due to their sheer size and complexity.

The profound unity of nature shines through this research. Mathematical principles can explain both colossal cosmic phenomena and microscopic quantum interactions. It's a testament to the elegance and interconnectedness of our physical world.

Einstein's legacy in a quantum world

The leap forward that Professor Shannon and his team have made in simulating gravitational waves in a lab has broadened our understanding of the universe.

Their work not only deepens our grasp of gravitational waves but also showcases the power of integrating [different scientific disciplines](#).

Through bridging the cosmic and the quantum, they've unlocked new paths of exploration, illuminating some of the deepest mysteries of our universe. Indeed,

when scientists dare to think differently, the boundaries of human knowledge expand, and new horizons open up.

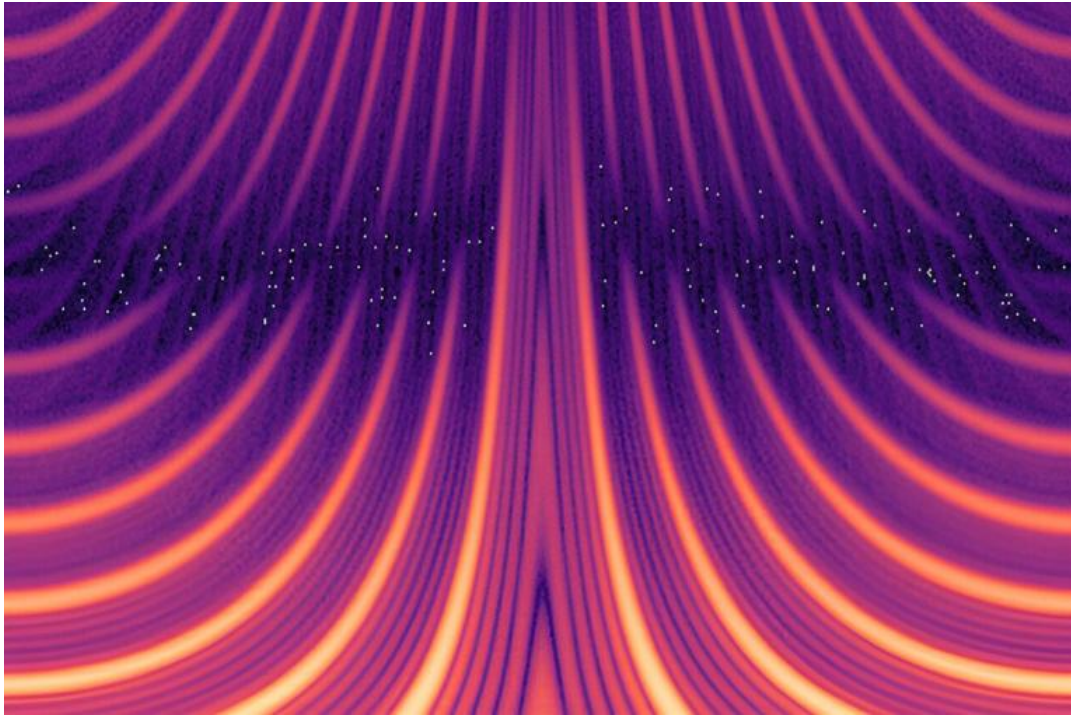

Illustration of a nuclear frequency comb displaying single photons as visualized on a logarithmic scale from dark to bright colors, with brighter colors indicating instances of time where the stored photons have a higher probability of being retrieved. These instances occur closer together for higher energy spacings and are more spread out in time for lower energy spacings. Credit: DESY/Sven Velten

Light is an excellent carrier of information used not only for classical communication technologies but also increasingly for quantum applications such as quantum networking and computing. However, processing light signals is far more complex, compared to working with common electronic signals.

An international team of researchers including Dr. Olga Kocharovskaya, a distinguished professor in the Department of Physics and Astronomy at Texas A&M University, has demonstrated a novel way of storing and releasing X-ray pulses at the single photon level—a concept first proposed in earlier theoretical work by Kocharovskaya's group—that could apply to future X-ray quantum technologies.

The team's work, led by Helmholtz Institute Jena Professor Dr. Ralf Röhlsberger and performed using the synchrotron sources PETRA III at the German Electron Synchrotron (DESY) in Hamburg and the European Synchrotron Radiation Facility in France, resulted in the first realization of quantum memory in the hard X-ray range.

Their findings [are published](#) in the journal *Science Advances*.

"Quantum memory is an indispensable element of the quantum network, providing storage and retrieval of quantum information," said Kocharovskaya, a member of the Texas A&M Institute for Quantum Science and Engineering.

"Photons are fast and robust carriers of quantum information, but it is difficult to hold them stationary in case this information is needed at a later time. A convenient way of doing this is by imprinting this information into a quasi-stationary medium in the form of polarization or spin wave with a long coherence time and releasing it back via re-emission of the original photons."

Kocharovskaya says several protocols for quantum memories have been established but are limited to optical photons and atomic ensembles. Using nuclear rather than atomic ensembles, she adds, delivers much longer memory times achievable even at high solid-state densities and room temperature.

Those longer memory times are a direct result of the lower sensitivity of nuclear transitions to perturbations by external fields, thanks to the small nuclei sizes. In combination with a tight focusing of the high-frequency photons, such approaches could lead to the development of long-lived broad-band compact solid-state quantum memories.

"The direct extension of the optical/atomic to X-ray/nuclear protocols proves to be challenging or impossible," explains Dr. Xiwen Zhang, a postdoctoral researcher in Kocharovskaya's group who participated in the experiment and co-authored the team's paper. "Thus, a new protocol was suggested in our earlier work."

According to Zhang, the idea behind the team's new protocol is very simple, at least in terms of quantum fundamentals. Essentially, a set of moving nuclear absorbers forms a frequency comb in the absorption spectrum due to the Doppler frequency shift caused by the motion.

A short pulse with the spectrum matching a comb absorbed by such a set of nuclear targets will be re-emitted with the delay determined by the inverse Doppler shift as a result of the constructive interference between different spectral components.

"This idea was successfully realized in our current experiment featuring one stationary and six synchronously moving absorbers that have formed a seven-teeth frequency comb," Zhang added.

Zhang says nuclear coherence lifetime is the limiting factor that determines the maximum storage time for this type of quantum memory. For instance, using longer-lived isomers than the iron 57 isotope the team chose for their current study would result in a longer memory time.

Regardless, he notes that working at a single-photon level without losing information qualifies the nuclear frequency comb protocol as a quantum memory, which is a first for X-ray energies.

The next steps planned by the team include on-demand release of the stored photon wave packets, which could lead to realization of the entanglement between different hard X-ray photons—the main resource for quantum information processing.

The team's research also highlights the potential for extending optical quantum technologies to the short wavelength range, which is intrinsically less "noisy" due to averaging of fluctuations over a large number of high-frequency oscillations.

Kocharovskaya says the challenging possibilities are intriguing and that she and her collaborators look forward to continuing to explore the potential of their tunable, robust and highly versatile platform to advance the field of quantum optics at X-ray energies in the near future.

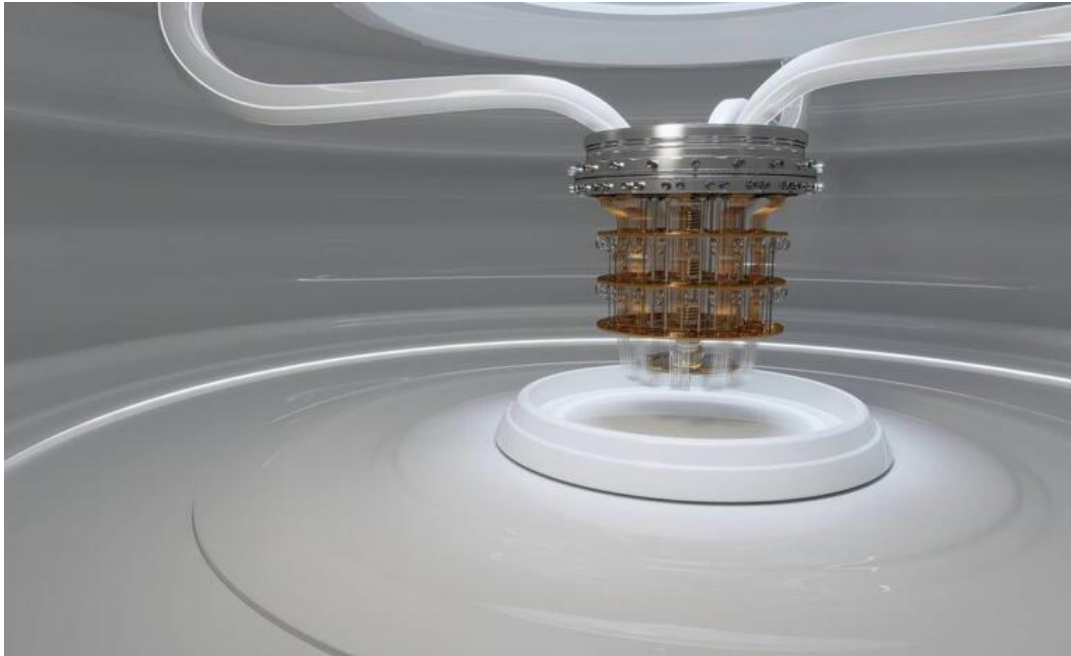

From vacuum tubes to qubits – is quantum computing destined to repeat history?© Provided by The Register

Having seen how conventional computers changed the world, can you really afford to bet against it?

Analysis The early 1940s saw the first vacuum tube computers put to work solving problems beyond the scope of their human counterparts. These massive machines were complex, specific, and generally unreliable....

In many respects, today's quantum systems bear remarkable similarities to early vacuum tube computers in that they're also incredibly expensive, specialized, and not intuitive.

Later computers like UNIVAC I in 1951 or the IBM 701 presented the possibility of a competitive advantage for the few companies with the budgets and expertise necessary to deploy, program, and maintain such beasts. According to Gartner analyst Matthew Brisse, a similar phenomenon is taking place with quantum systems today as companies seek to eke out efficiencies by any means necessary.

The topic of quantum supremacy – that is, scenarios where quantum systems outperform classical computers – is a topic of ongoing debate. But Brisse emphasizes "there is not a single thing that quantum can do today that you can't do classically."

However, he notes that by combining classical and quantum computing, some early adopters – particularly in the financial and banking industry – have been able to achieve some kind of advantage over classical computing alone. Whether these advantages rise to the level of a competitive edge isn't always clear, but it does contribute to a fear that those who don't invest early may risk missing out.

Should history repeat itself, as it so often does, it will be the early adopters of quantum systems who'll stand to gain the most, hence the FOMO. But is that fear well placed?

Governments, for example, have poured a significant amount into the possibility that quantum will materialize as a true competitive threat without having the "killer app" for quantum defined yet. Earlier this year, the Defense Advanced Research Projects Agency, better known as DARPA, launched the Underexplored Systems for Utility-Scale Quantum Computing (US2QC) initiative to speed the development and application of quantum systems. The idea behind it is that if a quantum system becomes capable of cracking modern encryption the way Colossus did to the German cyphers all those years ago, Uncle Sam doesn't want to be left playing catch up.

Whether encryption-cracking quantum systems are something we actually have to worry about is still open for debate, but the same logic applies to enterprises – especially those looking to get a leg up on their competitors in the medium to long term.

"It's not about what you can get today. It's about getting ready for innovations that are going to happen next," according to Brisse. "We are out of the lab and we are now looking at commercialization."

This is why companies like Toyota, Hyundai, BBVA, BSAF, ExxonMobil and others have teamed up with quantum computing vendors on the off chance the tech can help develop better batteries, optimize routes and logistics, and/or reduce investment risk.

But while commercialization of quantum computing may be underway, recent developments around generative AI may end up hampering adoption of the tech – at least in the short term.

Brisse notes that most CIOs are looking to invest in technologies with relatively short returns on investment. With GPUs and other accelerators used to power AI models, they can expect near-term results, while quantum computing remains a long-term investment.

Still, Brisse says he hasn't seen enterprises abandon their quantum investments, he's certainly seen a shift in priority toward generative AI.

Making matters worse for those trying to get hands-on with quantum, cross-shopping systems can be a bit of a minefield.

There are dozens of vendors claiming to offer quantum services on systems ranging anywhere from a few dozen qubits to thousands of them. While this might seem like an obvious metric to judge the maturity and performance of a quantum system, it really depends on a number of factors – including things like decoherence and the quality of the qubits themselves.

We liken this to the "core wars" on modern processors. Those on an Intel CPU are going to have vastly different performance characteristics compared to CUDA cores on an Nvidia GPU. Depending on what you're doing, a job that might run just fine on a handful of Intel cores might require thousands of CUDA cores – if it runs at all.

The same is true of quantum systems, which are often optimized to specific workloads. For example, Brisse argues that an IBM system might perform better at computational chemistry, while D-Wave systems may be better tuned for optimization tasks like route planning. "Different quantum systems solve quantum problems differently," he explained.

The high cost and often exotic conditions – like near-absolute-zero operating temperatures – mean that many quantum systems up to this point have been rented in a cloud-like "as-a-service" fashion. However some providers, like IonQ, have recently teased rackmount quantum systems that can be deployed in enterprise datacenters. It remains to be seen when these "forthcoming" machines will actually ship.

With that said, Brisse doesn't see much benefit to on-prem deployments apart from latency-sensitive applications just yet. He expects most on-prem

deployments will focus on scientific research – likely in conjunction with high performance computing deployments.

We've already seen this to a degree with Europe's Lumi supercomputer, which got a small quantum computing upgrade last autumn.

For Brisse this research is still important to move quantum computing beyond conventional problems.

"Today, we're only solving classical problems quantumly, but real innovation ... is going to come when we solve quantum problems quantumly with quantum algorithms," he opined. "That I believe is the big 'a-ha' in quantum: not whether we can go faster, whether we can actually solve new classes of problems." ®

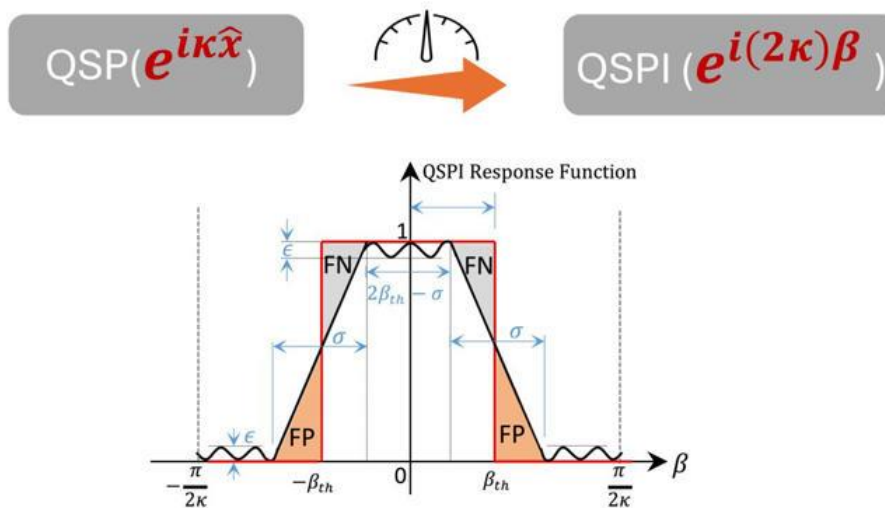

Pictorial illustration of how in the bosonic QSP interferometry (QSPI) protocol, the qubit measurement enacts a duality between a polynomial transformation on the bosonic quadrature operators \hat{x} and a polynomial transformation on the sensing parameter β via QSPI. Credit: Quantum (2024). DOI: 10.22331/q-2024-07-30-1427© Provided by Phys.org

Researchers from North Carolina State University and the Massachusetts

Institute of Technology have designed a protocol for harnessing the power of quantum sensors. The protocol could give sensor designers the ability to fine-tune quantum systems to sense signals of interest, creating sensors that are vastly more sensitive than traditional sensors.

A paper describing the work is [published](#) in the journal *Quantum*.

"Quantum sensing shows promise for more powerful sensing capability that can approach the fundamental limit set by the law of quantum mechanics, but the challenge lies in being able to direct these sensors to find the signals we want," says Yuan Liu, assistant professor of electrical and computer engineering and computer science at NC State and corresponding author of the research. Liu was formerly a postdoctoral researcher at MIT.

"Our idea was inspired by classical signal processing filter design principles that are routinely used by electrical engineers," Liu says. "We generalized these filter designs to quantum sensing systems, which allows us to 'fine-tune' what is essentially an infinite dimensional quantum system by coupling it to a simple two-level quantum system."

Specifically, the researchers designed an algorithmic framework that couples a qubit with a bosonic oscillator. Qubits, or quantum bits, are quantum computing's counterpart to classical computing's bits—they store quantum information and can only be in a superposition of two basis states: $|0\rangle$, $|1\rangle$. Bosonic oscillators are the quantum analog of classical oscillators (think of a pendulum's motion), and they share features similar to classical oscillators, but their states are not limited to a linear combination of only two basis states—they are infinite-dimensional systems.

"Manipulating the quantum state of an infinite-dimensional sensor is complicated, so we begin by simplifying the question," Liu says. "Instead of trying to figure out amounts of our targets, we just ask a decision question: whether the target has property X. Then we can design the manipulation of the oscillator to reflect that question."

By coupling the infinite dimensional sensor to the two-dimensional qubit and manipulating that coupling, the sensor could be tuned to a signal of interest. Interferometry is used to encode the results into the qubit state which is then measured for readout.

"This coupling gives us a handle on the bosonic oscillator, so we could use a polynomial function—math that describes wave forms—to engineer the oscillator's wave function to take a particular shape, thus attuning the sensor to the target of interest," Liu says.

"Once the signal happens, we undo the shaping, which creates interference in the infinite dimensional system that comes back as a readable result—a polynomial function determined by the original polynomial transformation of the oscillator and the underlying signal—in the qubit's two-level system. In other words, we end up with a 'yes' or 'no' answer to the question of whether the thing we're looking for is there. And the best part is that we only need to measure the qubit once to extract an answer—it's a 'single-shot' measurement."

The researchers see the work as providing a general framework for designing quantum sensing protocols for a variety of quantum sensors.

"Our work is useful because it utilizes readily available quantum resources in leading quantum hardware (including trapped ions, superconducting platform, and neutral atoms) in a fairly simple way," Liu says. "This approach serves as an alarm or indicator that a signal is there, without requiring costly repeated measurements. It's a powerful way to extract useful information efficiently from an infinite dimensional system."

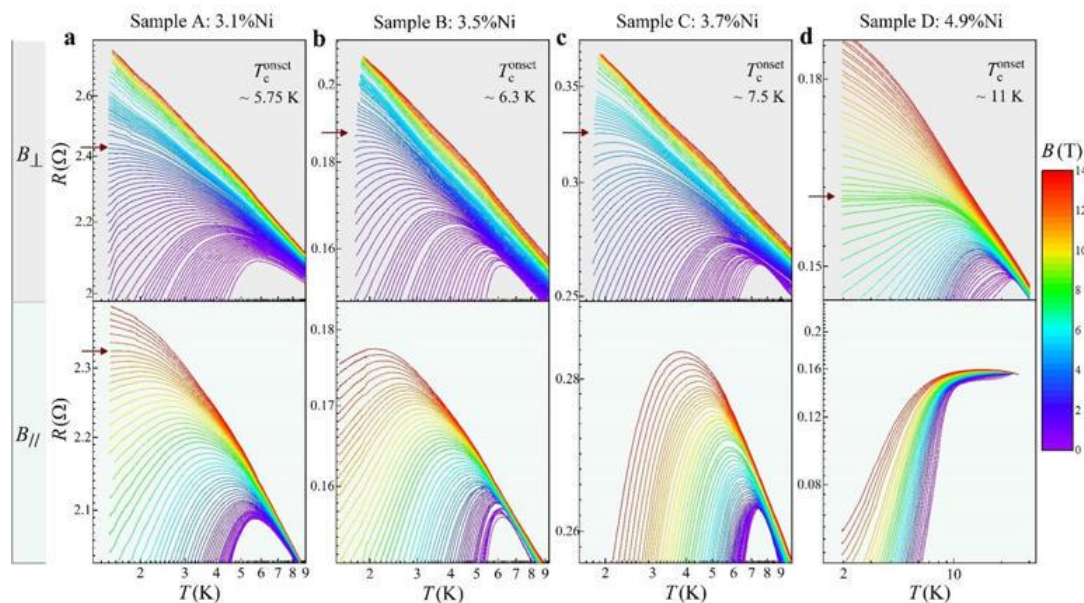

Magnetic-field-driven superconductor-metal phase transition with multiple quantum critical points in $\text{CaFe}_{1-x}\text{Ni}_x\text{AsF}$. Credit: Science China Press© Provided by Phys.org

Exploration of exotic quantum phase transitions has always been a focus in condensed matter physics. Critical phenomena in a phase transition are entirely determined by the universality class, which is controlled by the spatial and/or order-parameters and is independent of microscopic details.

The quantum phase transition is a class of phase transitions that occurs due to quantum fluctuations, tuned by certain parameters of the system at the zero-temperature limit. The superconductor-insulator/metal phase transition is a classic example of quantum phase transition, which has been intensely studied for more than 40 years.

Disorder is considered one of the most important influencing factors, and therefore has received widespread attention. During the phase transitions, the system usually satisfies scaling invariance, so the universality class will be characterized by a single critical exponent. In contrast, the peculiarity of quantum Griffith singularity is that it breaks the traditional scaling invariance, where exotic physics emerges.

The physics of Griffiths singularity dates back to 1969, when American physicist Griffiths proposed a type of phase transition in which the scaling invariance is broken. In this case, the critical exponent tends to diverge rather than remain constant. The quantum Griffith singularity refers to the Griffith singularity in a quantum phase transition.

Since the proposal of quantum Griffith singularity, it has only been observed in conventional low-dimensional superconducting films and in a few three-dimensional ferromagnets. The existence of quantum Griffith singularity in three-dimensional superconductors and in unconventional high-temperature superconductors has yet to be confirmed experimentally. Such confirmation will shed light on the understanding of mechanisms in unconventional high-temperature superconductivity.

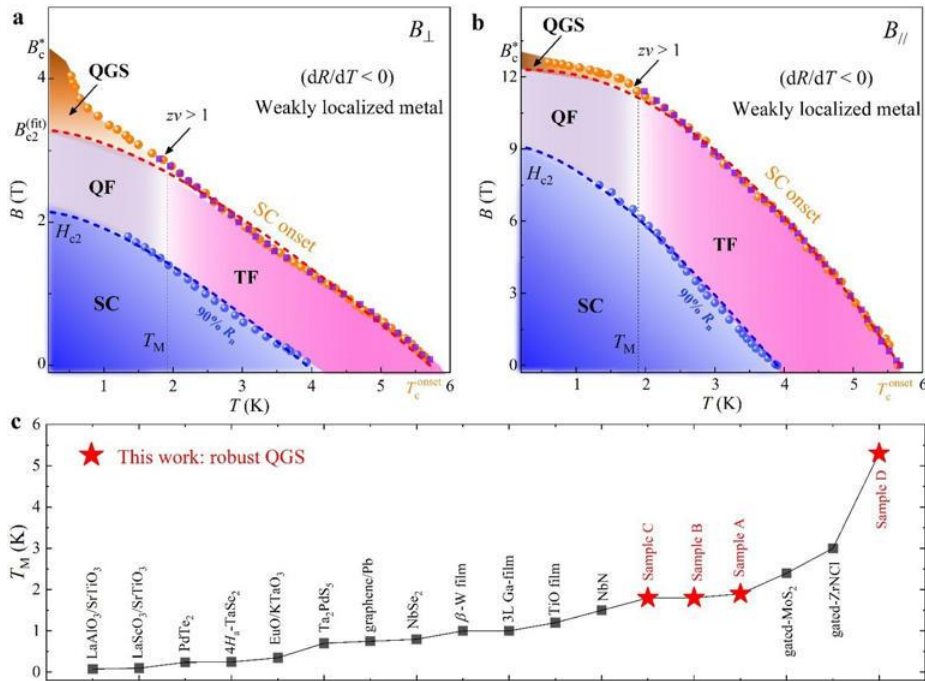

B-T phase diagram of quantum Griffiths singularity in a three-dimensional anisotropic superconductor. Credit: Science China Press© Provided by Phys.org

Recently, a research group led by Jian-Hao Chen, a researcher at the International Center for Quantum Materials at the School of Physics at Peking University, the Beijing Academy of Quantum Information Sciences, and the Key Laboratory for the Physics and Chemistry of Nanodevices of Peking University, conducted a study on the quantum Griffith singularity in unconventional high-temperature superconducting bulk single crystal $\text{CaFe}_{1-x}\text{Ni}_x\text{AsF}$.

They and their collaborators grew a series of high-quality underdoped $\text{CaFe}_{1-x}\text{Ni}_x\text{AsF}$ bulk single crystals for the first time, and observed the evolution of quasi two-dimensional to three-dimensional anisotropic quantum Griffith singularities in the superconductor-metal phase transitions driven by magnetic fields. They found robust quantum Griffith singularity which can last up to 5.3 K, and it can be induced in the crystals by both parallel and vertical magnetic fields.

This study not only reveals the universality of quantum Griffith singularity in three-dimensional and unconventional high-temperature superconducting systems, but also predicts the possibility of finding quantum Griffith states in more unconventional high-temperature superconducting families (i.e., nickel-based and copper-based superconductors), which may further promote the understanding of unconventional high-temperature superconductivity mechanisms.

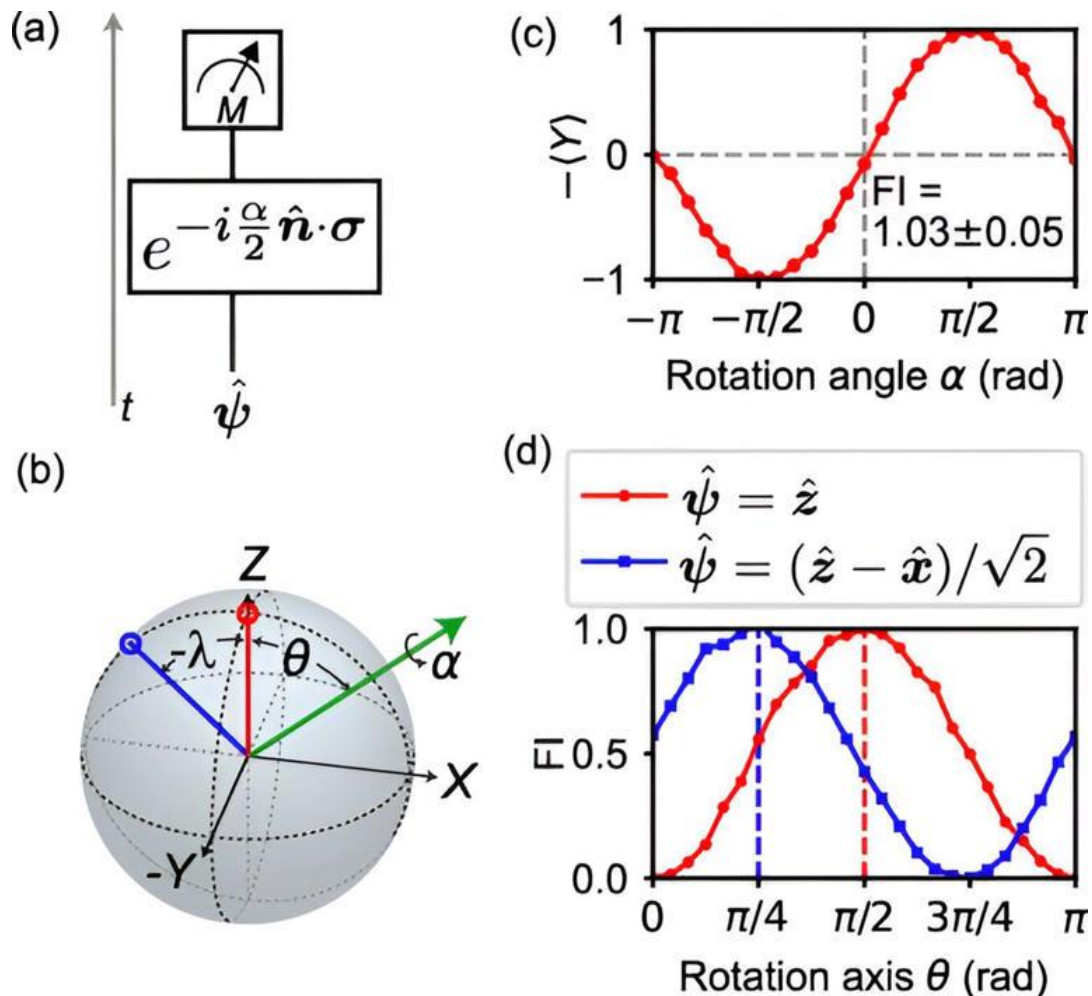

Fisher information achievable with single-qubit sensor. Credit: Physical Review Letters (2024). DOI: 10.1103/PhysRevLett.132.260801 © Provided by Phys.org

The idea of time travel has dazzled sci-fi enthusiasts for years. Science tells us that traveling to the future is technically feasible, at least if you're willing to go near the speed of light, but going back in time is a no-go. But what if scientists could leverage the advantages of quantum physics to uncover data about complex systems that happened in the past?

New research indicates that this premise may not be that far-fetched. In a paper [published](#) June 27, 2024, in *Physical Review Letters*, Kater Murch, the Charles M. Hohenberg Professor of Physics and Director of the Center for

Quantum Leaps at Washington University in St. Louis, and colleagues Nicole Yunger Halpern at NIST and David Arvidsson-Shukur at the University of Cambridge demonstrate a new type of quantum sensor that leverages quantum entanglement to make time-traveling detectors.

Murch describes this concept as analogous to being able to send a telescope back in time to capture a shooting star that you saw out of the corner of your eye. In the everyday world, this idea is a non-starter. But in the mysterious and enigmatic land of quantum physics, there may be a way to circumvent the rules. This is thanks to a property of entangled quantum sensors that Murch refers to as "hindsight."

The process begins with entanglement of two quantum particles in a quantum singlet state—in other words, two qubits with opposite spin—so that no matter what direction you consider, the spins point in opposing directions. From there, one of the qubits—the "probe," as Murch calls it—is subjected to a magnetic field that causes it to rotate.

The next step is where the proverbial magic happens. When the ancillary qubit (the one not used as the probe in the experiment) is measured, the properties of entanglement effectively send its quantum state (i.e. spin) "back in time" to the other qubit in the pair. This takes us back to the second step in the process, where the magnetic field rotated the "probe qubit," and it is where the real advantage of hindsight comes in.

Under usual circumstances for this kind of experiment, where the rotation of a spin is used to measure the size of a magnetic field, there is a one-in-three chance that the measurement will fail. This is because when the magnetic field interacts with the qubit along the x-, y-, or z-axis, if it is parallel or antiparallel to the direction of spin, the results will be nullified—there will be no rotation to measure.

Under normal conditions, when the magnetic field is unknown, scientists would have to guess along which direction to prepare the spin, leading to the one-third possibility of failure. The beauty of hindsight is that it allows experimenters to set the best direction for the spin—in hindsight—through time travel.

Einstein once referred to quantum entanglement as "spooky action at a distance." Perhaps the spookiest part about entanglement is that we can consider

entangled particle pairs as being the very same particle, going both forward and backwards in time.

That gives quantum scientists creative new ways to build better sensors—in particular ones that you can effectively send backwards in time. There are a number of potential applications for these kinds of sensors, from detecting astronomical phenomena to the aforementioned advantage gained in studying magnetic fields, and more will surely come into focus as the concept is developed further.



New quantum computer record smashes Google supremacy by 100 folds© Provided by Interesting Engineering

A new quantum computer has shattered the world record set by Google's Sycamore machine. The new 56-qubit H2-1 computer smashed 'quantum supremacy' record by 100-fold.

Between January and June 2024, Quantinuum, a computing company, ran multiple experiments on its new 56-qubit H2-1 computer to benchmark the machine's performance levels and the quality of the qubits used.

"We are entirely focused on the path to universal fault tolerant quantum computers," said Ilyas Khan, Chief Product Officer.

“This objective has not changed, but what has changed in the past few months is clear evidence of the advances that have been made possible due to the work and the investment that has been made over many, many years.”

Error correction performance threshold

The company maintained that with its long-time partner Microsoft, we hit an error correction performance threshold that many believed was still years away.

The System Model H2 became the first – and only – [quantum computer](#) in the world capable of creating and computing with highly reliable logical (error corrected) qubits, according to [Quantinuum](#).

The collaboration tackled a well-known [algorithm](#), Random Circuit Sampling (RCS), and measured the quality of our results with a suite of tests including the linear cross entropy [benchmark](#) (XEB) – an approach first made famous by Google in 2019 in a bid to demonstrate “quantum supremacy”.

Results on H2-1 are excellent

An XEB score close to 0 says your results are noisy – and do not utilize the full [potential](#) of quantum computing. In contrast, the closer an XEB score is to 1, the more your results demonstrate the power of quantum computing. The results on H2-1 are excellent, revealing, and worth exploring in a little detail, said the company.

“Results show that whilst the full benefits of fault tolerant quantum computers have not changed in nature, they may be reachable earlier than was originally expected,” added Khan.

He explained that there will be tangible benefits to our customers in their day-to-day operations as quantum computers start to perform in ways that are not classically simulatable.

“We have an exciting few months ahead of us as we unveil some of the applications that will start to matter in this context with our partners across a number of sectors.”

Able to run circuits on all 56 qubits in H2-1

In 2019, Google’s Sycamore quantum computer registered an XEB result of approximately 0.002 with the 53 superconducting qubits built into Sycamore. It was demonstrated Sycamore can complete a calculation in 200 seconds that would have taken the most powerful supercomputer at the time 10,000 years to finish.

But in the new study, Quantinuum scientists achieved an XEB score of approximately 0.35. This means the H2 quantum computer can produce results without producing an error 35% of the time, reported [Live Science](#).

[Quantinuum](#) maintained that they have been able to run circuits on all 56 qubits in H2-1 that are deep enough to challenge high-fidelity classical simulation while achieving an estimated XEB score of ~0.35.

This >100x improvement implies the following: even for circuits large and complex enough to frustrate all known classical simulation methods, the H2 quantum computer produces results without making even a single error about 35% of the time.

In contrast to past announcements associated with XEB experiments, 35% is a significant step towards the idealized 100% fidelity limit in which the computational advantage of quantum computers is clearly in sight.



Higgs boson 'God particle' still remains a quantum mystery after 12 years© Provided by Earth

The discovery of the Higgs boson has been a captivating journey for physicists worldwide since the particle was first detected in the Large Hadron Collider (LHC) about twelve years ago.

This monumental finding, confirming the existence of the elusive particle theorized almost half a century prior, has unlocked new avenues of exploration and understanding in particle physics.

Despite dedicated research, the properties of this enigmatic particle remain somewhat shrouded in mystery.

Today, the scientific community embraces a new breakthrough that brings us a step closer to understanding the origin of the Higgs boson.

Understanding the Higgs Boson

This exciting breakthrough comes from an international group of theoretical physicists, including members from the [Institute of Nuclear Physics](#) of the Polish Academy of Sciences.

These scientists have pooled their expertise and resources in a concerted effort to unravel the complexities of the Higgs boson.

For many years, the Higgs boson has remained the crowning glory of discoveries made with the [Large Hadron Collider](#).

Yet, understanding its properties has proven to be a colossal challenge, mainly due to the scientific hurdles encountered during experimental and computational studies.

Complex maze of the Standard Model

Established in the 1970s, the [Standard Model](#) is a theoretical framework designed to explain the elementary particles of matter accurately.

From [quarks to electrons](#), this model has been instrumental in understanding how various electromagnetic and nuclear forces interact.

The Higgs boson, discovered thanks to the LHC, is the coveted jewel of the [Standard Model](#). It holds a pivotal role in the mechanism that bestows masses to other elementary particles.

Without the Higgs field, particles would not have mass, and the universe as we know it would be drastically different.

Delving deeper into the quantum realm

Dr. Rene Poncelet from the IFJ PAN, part of this important research, provides clarity on the significance of their work.

"We have focused on the theoretical determination of the Higgs boson cross section in gluon-gluon collisions. These collisions are responsible for the production of about 90% of the Higgs, traces of whose presence have been registered in the detectors of the LHC accelerator," Poncelet explained.

This work delves deeper into the [quantum realm](#), where interactions are governed by the rules of quantum mechanics, offering deeper insights into the fundamental workings of our universe.

One of the co-authors of this research, Prof. Michal Czakon from the RWTH, explains why their work is a scientific achievement.

"The essence of our work was the desire to take into account, when determining the active cross section for the production of Higgs bosons, certain corrections that are usually neglected because ignoring them significantly simplifies the calculations," Czakon claims.

"It's the first time we have succeeded in overcoming the mathematical difficulties and determining these corrections."

This finding is a triumph over mathematical challenges and a testament to the rigorous and meticulous nature of scientific inquiry.

Seeing the bigger picture

This work has contributed to a more profound understanding of the Higgs bosons and opened avenues for further research.

The team's findings indicate that the mechanisms responsible for the formation of Higgs bosons, at least for now, show no signs of diverging from the established physics.

However, questions still abound:

Why do elementary particles carry the masses they do?

Why do they form families?

What exactly is [dark matter](#)?

What causes the dominance of matter over antimatter in the Universe?

These inquiries take us beyond the scope of the Standard Model, hinting at the existence of "new physics." The pursuit to answer these questions is not just about theoretical curiosity; it has the potential to revolutionize our understanding of the universe and even lead to new technologies.

What's next for the Higgs Boson "God particle"

In the coming years, as more particle collisions are observed with the fourth research cycle of the LHC, reducing measurement uncertainties and bringing us closer to understanding the Higgs boson may be possible.

Each new cycle of experiments at the LHC is like turning a page in a giant book of the universe, revealing new insights and deepening our comprehension of the cosmos.

For now, the Standard Model remains secure, standing strong in the face of mysteries yet to be unraveled in the world of quantum mechanics. Let's brace ourselves; the quest to solve these mysteries promises to be nothing short of fascinating.

This journey reflects the enduring human spirit to explore the unknown, a spirit that has driven scientific and technological progress throughout history.

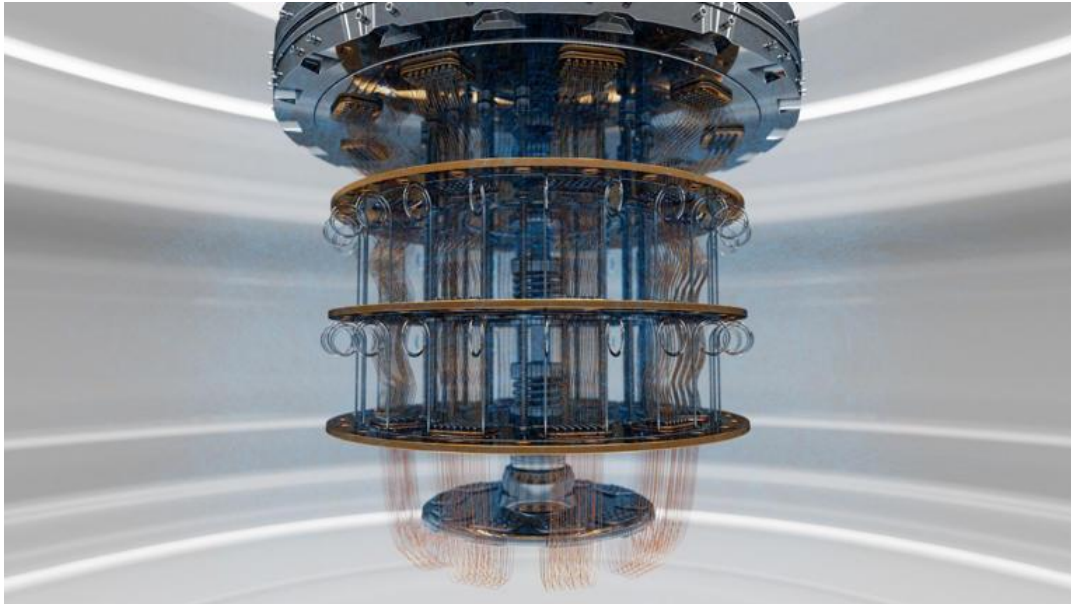

Scientists beat supercomputers with quantum tech that simulates electron motion© Provided by Interesting Engineering

A Chinese research team has achieved a significant milestone in quantum computing by successfully building a device that can simulate the movement of electrons within a solid-state material.

This research, published in the journal *Nature*, showcases the potential of quantum computers to surpass even the most powerful supercomputers.

Understanding electron behavior is crucial for scientific advancements, particularly in the fields of magnetism and high-temperature superconducting materials. These materials could revolutionize electricity transmission and transportation, leading to significant energy savings and technological progress.

“Our achievement demonstrates the capabilities of quantum simulators to exceed those of classical computers, marking a milestone in the second stage of China’s quantum computing research,” said team leader Pan Jianwei from the University of Science and Technology of China.

For reference, the second stage of quantum computing focuses on developing specialized quantum simulators. These simulators are designed to tackle specific

scientific problems that are too complex for classical computers to handle efficiently.

A complex challenge

The research team focused on simulating the fermionic Hubbard model (FHM). It is a theoretical model describing electron motion within lattices, proposed by British physicist John Hubbard in 1963.

However, despite its importance in explaining high-temperature superconductivity, this model is notoriously difficult to simulate due to its complexity.

Besides, there is no exact solution for this model in two or three dimensions, and even the most powerful supercomputers struggle to explore its full parameter space due to high computational demands.

Chen Yuao, a co-author of the paper, [explained](#) that simulating the movement of 300 electrons using classical computers would require storage space exceeding the total number of atoms in the universe.

Overcoming challenges in quantum simulation

[Quantum](#) simulation involves using ultracold fermionic atoms in optical lattices to map out the low-temperature phase diagram of the FHM.

However, previous quantum simulation experiments faced challenges in realizing the antiferromagnetic phase transition due to the difficulty in cooling fermionic atoms and the inhomogeneity introduced by standard Gaussian-profile lattice lasers.

To overcome the challenges associated with simulating the Hubbard model, the team combined machine-learning optimization techniques with their previous work on homogeneous Fermi superfluids.

This enabled them to create optical lattices with uniform intensity distribution, achieve ultra-low temperatures, and develop new measurement techniques to characterize the states of the quantum simulator accurately.

Breakthrough observation, promising future

The research culminated in the observation of a switch in a material from a paramagnetic state (weakly attracted to a magnet) to an antiferromagnetic state (largely insensitive to a magnet). This finding can further our understanding of [high-temperature](#) superconductivity mechanisms.

“Once we fully understand the physical mechanisms of high-temperature superconductivity, we can scale up the design, production, and application of new high-temperature superconducting materials, potentially revolutionizing fields such as electric power transmission, medicine, and supercomputing,” stated Chen while emphasizing the potential impact of this research.

This breakthrough marks a significant step forward in quantum computing research. It can immensely contribute to developing specialized quantum simulators to tackle scientific problems beyond the capabilities of classical computers.

The Smartphone Revolution

In 2007 ^(ref), the world witnessed the launch of Apple’s iPhone, a device that didn’t just upgrade existing technology but revolutionized it.

With each iteration, from the iPhone 5s to the current iPhone 14, we’ve seen enhancements in power, camera quality, and functionality. However, the fundamental design and user interface have remained surprisingly consistent.

This brings us to a critical question: Have we reached the pinnacle of smartphone innovation?

Peak Smartphone: The Crossroads of Technological Evolution

Today, we stand at a crossroads in the evolution of communication technology. We face two possibilities: either smartphones have reached their final form, with only incremental upgrades in the future, or a new, disruptive technology is on the horizon, ready to replace smartphones as we know them.

The pressure is immense on the world's wealthiest companies to innovate and lead us into the next era of communication technology.

The Future of Communication

Image Credit: Hadrian/Shutterstock.© Provided by Viral Chatter

The future seems to be gravitating towards augmented reality (AR) and artificial intelligence (AI).

Apple's Vision Pro [\(ref\)](#) and Meta's Quest [\(ref\)](#) are examples of how technology is moving towards more immersive experiences. These devices aim to integrate digital information seamlessly into our physical world, potentially replacing the traditional smartphone screen with a more dynamic, interactive interface.

AI Pin: A Step Towards Invisible Technology

Companies like Humane Inc are exploring new frontiers with devices like the AI Pin. This wearable device acts as a personal assistant, blending into the background of our lives.

It offers a hands-free experience, projecting information onto surfaces like your hand, and is controlled by voice and gestures.

Representing a shift towards making technology less intrusive and more integrated into our daily experiences.

The Future is Now: Embracing the Next Wave of Tech Innovations

As we ponder over the next big leap in communication technology, it's clear that the future holds exciting possibilities.

Be it smart glasses, AI assistants, or yet-to-be-invented devices, the way we interact with technology is poised for a significant transformation. These innovations promise to make our interaction with technology more natural and integrated, marking another milestone in the ever-evolving journey of communication technology.

[DeepMind](#) has unveiled the third version of its [artificial intelligence](#) (AI)-powered structural biology software, AlphaFold, which models how proteins fold.

Structural biology is the molecular basis study of biological materials — including proteins and nucleic acids —and aims to reveal how they are structured, work, and interact.

AlphaFold3 helps scientists more accurately predict how proteins — large molecules that play a critical role in all life forms, from plants and animals to human cells — interact with other biological molecules, including DNA and RNA. Doing so will enable scientists to “truly understand life’s processes,” DeepMind representatives wrote [in a blog post](#).

By comparison, its predecessors, AlphaFold and AlphaFold2, could only predict the shapes that proteins fold into. That was still a [major scientific breakthrough at the time](#).

AlphaFold3's predictions could help scientists develop bio-renewable materials, crops with greater resistance, new drugs and more, the research team wrote in a study published May 8 in the journal [Nature](#).

[Related: 'Master of deception': Current AI models already have the capacity to expertly manipulate and deceive humans](#)

Given a list of molecules, the AI program can show how they fit together. It does this not only for large molecules like proteins, DNA, and RNA but also for small

molecules known as ligands, which bind to receptors on large proteins like key fitting into a lock.

AlphaFold3 also models how some of these biomolecules (organic molecules produced by living things) are chemically modified. Disruptions in these chemical modifications can play a role in diseases, according [to the blog post](#).

AlphaFold3 can perform these calculations because its underlying machine-learning architecture and training data encompasses every type of biomolecule.

The researchers claim that AlphaFold3 is 50% more accurate than current software-based methods of predicting protein structures and their interactions with other molecules.

For example, in drug discovery, [Nature reported](#) that AlphaFold3 outperformed two docking programs — which researchers use to model the affinity of small molecules and proteins when they bind together — and RoseTTAFold All-Atom, a neural network for predicting biomolecular structures.

Frank Uhlmann, a biochemist at the Francis Crick Institute in London, told Nature that he's been using the tool for predicting the structure of proteins that interact with DNA when copying genomes and experiments show the predictions are mostly accurate.

However, unlike its predecessors, AlphaFold 3 is no longer open source. This means scientists cannot use custom versions of the AI model, or access its code or training data publicly, for their research work.

Scientists looking to use AlphaFold3 for non-commercial research can access it for free via the recently launched [AlphaFold Server](#). They can input their desired molecular sequences and gain predictions within minutes. But they can only perform 20 jobs per day.

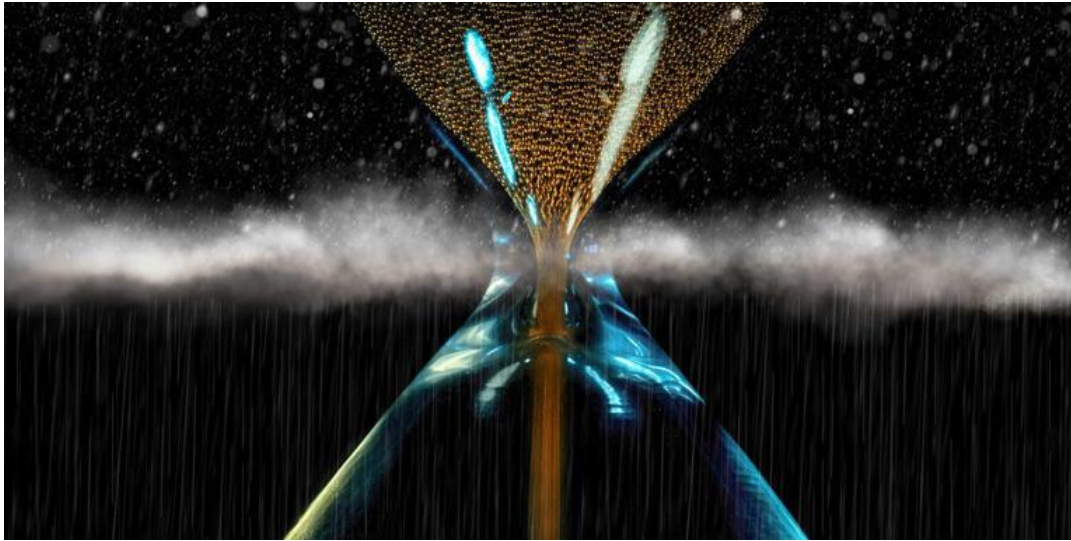

How engineers could use time crystals in quantum circuit boards to significantly reduce errors and overcome major challenges in quantum computing. © Florencio Horcajo Alvarez - Getty Images

- Arguably the greatest engineering challenge in quantum computing is addressing these systems' predilection for errors.
- Now, a new study from scientists from Australia and Poland says that creating a kind of quantum circuit board using time crystals could help overcome these challenges by spreading qubits and keeping them in motion.
- This idea, known as "time-tronics," could form the foundation of a more reliable quantum computer.

Quantum computers, by just their name alone, *scream* "future"—but it's a future that's still likely many more decades away. That's because building one of these machines is a dizzying engineering headache that relies on [superconductors](#), qubits (a quantum bit that's in superposition so it's both a "1" and "0"), and lots of other dizzying quantum weirdness. And to make matters worse, those qubits are also prone to errors. [Lots and lots of errors.](#)

That's not necessarily the fault of the quantum computers, but the qubits themselves. Because when qubits interact to run calculations, they inherently degrade themselves, which in turn produces errors.

Now, a new study posted to the [preprint server arXiv](#), by scientists in Australia and Poland, says that using [time crystals](#) as a kind of circuit board in next-gen quantum computers could make more reliable systems by “enabling quantum gate operations for all possible pairs of qubits,” according to the authors. Similar to electronics, they coined the term “time-tronics” to explain their new breakthrough.

“The elements of these devices can correspond to structures of dimensions higher than three and can be arbitrarily connected and reconfigured at any moment,” [the paper reads](#). “Our findings indicate that the limitations faced in building devices using conventional spatial crystals can be overcome by adopting crystalline structures in time.”

Although it sounds like an unimaginative name for a fantasy film [MacGuffin](#), time crystals are quantum phase of matter that aren’t *really* crystals—at least not how our three-dimensional minds think of them. While a spatial crystal has an intricate, repeating lattice of atoms, time crystals contain a periodic pattern of motion, which makes them a repeating lattice of time rather than space.

[According to](#) *New Scientist*, this particular composition is what makes time crystals a perfect candidate for a quantum computer circuit board because qubits would be “spread out and always in motion.” This makes interactions among qubits, including connections between distant qubits which is currently impossible in modern quantum computers, relatively easy and produce more reliable results.

“As any connections between sites can be controlled, it is possible to realize a broad class of quantum devices,” the paper reads.

“We demonstrate that a temporal printed circuit board can host qubits, where all single-qubit operations can be realized and a controlled-Z gate can be performed between all possible qubit pairs, meeting the conditions for a universal quantum computer.”

Going forward, the team is focusing on creating time crystals using the Bose-Einstein condensate of Potassium-39, which was chosen for its ability for scientists to accurately tune interactions among atoms precisely. If it works, this breakthrough won't revolutionize quantum computing overnight, but it could bring the field one big step closer to solving what's been described as its most ["defining challenge."](#)

Quantum computing

Why error correction is quantum computing's defining challenge

25 Mar 2024

Steve Brierley argues that quantum computers must implement comprehensive error-correction techniques before they can become fully useful to society



Exploiting their advantage Quantum computers will only become useful once hardware and software tools can control inherently unstable qubits. (Courtesy: Riverlane)

“There are no persuasive arguments indicating that commercially viable applications will be found that *do not* use quantum error-correcting codes and fault-tolerant quantum computing.” So stated the Caltech physicist John Preskill during a talk [at the end of](#)

[2023](#) at the Q2B23 meeting in California. Quite simply, anyone who wants to build a practical quantum computer will need to find a way to deal with errors.

Quantum computers are getting ever more powerful, but their fundamental building blocks – quantum bits, or qubits – are highly error prone, limiting their widespread use. It is not enough to simply build quantum computers with more and better qubits. Unlocking the full potential of quantum-computing applications will require new hardware and software tools that can control inherently unstable qubits and comprehensively correct system errors 10 billion times or more per second.

Preskill's words essentially announced the dawn of the so-called [Quantum Error Correction](#) (QEC) era. [QEC](#) is not a new idea and firms have for many years been developing technologies to protect the information stored in qubits from errors and decoherence caused by noise. What is new, however, is giving up on the idea that today's noisy intermediate scale devices (NISQ) could outperform classical supercomputers and run applications that are currently impossible.

Sure, NISQ – a term that was coined by Preskill – was an important stepping stone on the journey to fault tolerance. But the quantum industry, investors and governments must now realize that error correction is quantum computing's defining challenge.

A matter of time

QEC has already seen unprecedented progress in the last year alone. In 2023 [Google](#) demonstrated that a 17-qubit system could recover from a single error and a 49-qubit system from two errors ([Nature 614 676](#)). [Amazon](#) released a chip that suppressed errors 100 times, while [IBM scientists](#) discovered a new error-correction scheme that works with 10 times fewer qubits ([arXiv:2308.07915](#)). Then at the end of the year, researchers at Harvard University produced the largest yet number of [error-corrected qubits](#) .

Decoding, which turns many unreliable physical qubits into one or more reliable “logical” qubits, is a core QEC technology. That's because large-scale quantum computers will generate terabytes of data every second that have to be decoded as fast as they are acquired to stop errors propagating and rendering calculations useless. If we don't decode fast enough, we will be faced with an [exponentially growing backlog of data](#).

My own company – Riverlane – last year introduced [the world’s most powerful quantum decoder](#). Our decoder is solving this backlog issue but there’s still [a lot more work to do](#). The company is currently developing “streaming decoders” that can process continuous streams of measurement results as they arrive, not after an experiment is finished. Once we’ve hit that target, there’s more work to do. And decoders are just one aspect of QEC – we also need high-accuracy, high-speed “control systems” to read and write the qubits.

As quantum computers continue to scale, these decoder and control systems must work together to produce error-free logical qubits and, by 2026, Riverlane aims to have built an adaptive, or real-time, decoder. Today’s machines are only capable of a few hundred error-free operations but future developments will work with quantum computers capable of processing a million error-free quantum operations (known as a MegaQuOp).

Riverlane is not alone in such endeavours and other quantum companies are now prioritizing QEC. IBM has not previously worked on QEC technology, focusing instead on more and better qubits. But the firm’s [2033 quantum roadmap](#) states that IBM aims to build a 1000-qubit machine by the end of the decade that is capable of useful computations – such as simulating the workings of catalyst molecules. Quera, meanwhile, [recently unveiled its roadmap](#) that also prioritizes QEC, while the [UK’s National Quantum Strategy](#) aims to build quantum computers capable of running a trillion error-free operations (TeraQuOps) by 2035. Other nations have published similar plans and a 2035 target feels achievable, partly because the quantum-computing community is starting to aim for smaller, incremental – but just as ambitious – goals.

What really excites me about the UK’s National Quantum Strategy is the goal to have a MegaQuOp machine by 2028. Again, this is a realistic target – in fact, I’d even argue that we’ll reach the MegaQuOp regime sooner, which is why Riverlane’s QEC solution, Deltaflow, will be ready to work with these MegaQuOp machines by 2026. We don’t need any radically new physics to build a MegaQuOp quantum computer – and such a machine will help us better understand and profile quantum errors.

Once we understand these errors, we can start to fix them and proceed toward TeraQuOp machines. The TeraQuOp is also a floating target – and one where

improvements in both the QEC and elsewhere could result in the 2035 target being delivered a few years earlier.

It is only a matter of time before quantum computers are useful for society. And now that we have a co-ordinated focus on quantum error correction, we will reach that tipping point sooner rather than later.

Researchers at ETH Zurich have shown that quantum states of single electron spins can be controlled by currents of electrons whose spins are evenly aligned. In the future, this method could be used in electronic circuit elements.

Electrons have an intrinsic angular momentum, the so-called spin, which means that they can align themselves along a magnetic field, much like a compass needle. In addition to the electric charge of electrons, which determines their behavior in electronic circuits, their spin is increasingly used for storing and processing data.

Already, one can buy MRAM memory elements (magnetic random access memories), in which information is stored in very small but still classical magnets—that is, containing very many electron spins. The MRAMs are based on currents of electrons with spins aligned in parallel that can change the magnetization at a particular point in a material.

Pietro Gambardella and his collaborators at ETH Zurich now show that such spin-polarized currents can also be used to control the quantum states of single electron spins. Their results, which have just been [published](#) in the journal *Science*, could be used in different technologies in the future, for instance in the control of quantum states of quantum bits (qubits).

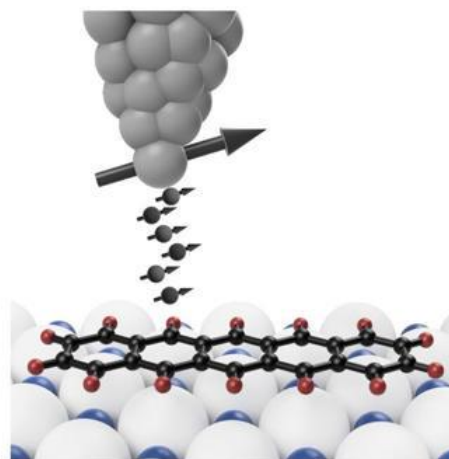
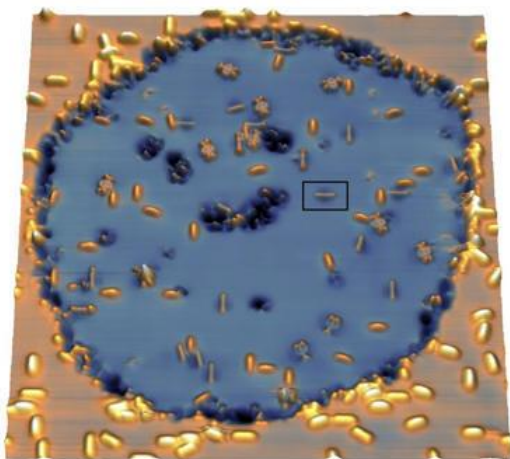

Left: Single pentacene molecules (yellow) on the insulating layer (blue). Right: Electrons with spins aligned in parallel (small arrows) tunnel from the tungsten tip (top) to the molecule (bottom). Credit: ETH Zürich / Aishwarya Vishwakarma und Stepan Kovarik© Provided by Phys.org

Tunnel currents in single molecules

"Traditionally, electron spins are manipulated using electromagnetic fields such as radio-frequency waves or microwaves," says Sebastian Stepanow, a Senior Scientist in Gambardella's laboratory. This technique, also known as electron paramagnetic resonance, was developed in the mid-1940s and has since been used in different fields such as materials research, chemistry and biophysics.

"A few years ago, it was demonstrated that one can induce electron paramagnetic resonance in single atoms; however, so far the exact mechanism for this has been unclear," says Stepanow.

To study the quantum mechanical processes behind this mechanism more closely, the researchers prepared molecules of pentacene (an aromatic hydrocarbon) on a silver substrate. A thin insulating layer of magnesium oxide had previously been deposited on the substrate. This layer ensures that the electrons in the molecule behave more or less as they would in free space.

Using a scanning tunneling microscope, the researchers first characterized the electron clouds in the molecule. This involves measuring the current that is created when the electrons tunnel quantum mechanically from the tip of a tungsten needle to the molecule. According to the laws of classical physics, the

electrons should not be able to hop across the gap between the tip of the needle and the molecule because they lack the necessary energy. Quantum mechanics, however, allows the electrons to "tunnel" through the gap in spite of that lack, which leads to a measurable current.

Miniature magnet on the tip of a needle

This tunnel current can be spin-polarized by first using the tungsten tip to pick up a few iron atoms, which are also on the insulating layer. On the tip, the iron atoms create a kind of miniature magnet. When a tunnel current flows through this magnet, the spins of the electrons in the current all align parallel to its magnetization.

The researchers applied a constant voltage as well as a fast-oscillating voltage to the magnetized tungsten tip, and they measured the resulting tunnel current. By varying the strength of both voltages and the frequency of the oscillating voltage, they were able to observe characteristic resonances in the tunnel current. The exact shape of these resonances allowed them to draw conclusions about the processes that occurred between the tunneling electrons and those of the molecule.

Direct spin control by polarized currents

From the data, Stepanow and his colleagues were able to glean two insights. On the one hand, the electron spins in the pentacene molecule reacted to the electromagnetic field created by the alternating voltage in the same way as in ordinary electron paramagnetic resonance. On the other hand, the shape of the resonances suggested that there was an additional process that also influenced the spins of the electrons in the molecule.

"That process is the so-called spin transfer torque, for which the pentacene molecule is an ideal model system," says Ph.D. student Stepan Kovarik. Spin transfer torque is an effect in which the spin of the molecule is changed under the influence of a spin-polarized current without the direct action of an electromagnetic field. The ETH researchers demonstrated that it is also possible

to create quantum mechanical superposition states of the molecular spin in this way. Such superposition states are used, for instance, in quantum technologies.

"This spin control by spin-polarized currents at the quantum level opens up various possible applications," says Kovarik. In contrast to electromagnetic fields, spin-polarized currents act very locally and can be steered with a precision of less than a nanometer. Such currents could be used to address electronic circuit elements in quantum devices very precisely and thus, for instance, control the quantum states of magnetic qubits.

More information: Stepan Kovarik et al, Spin torque-driven electron paramagnetic resonance of a single spin in a pentacene molecule, *Science* (2024). DOI: [10.1126/science.adh4753](https://doi.org/10.1126/science.adh4753)

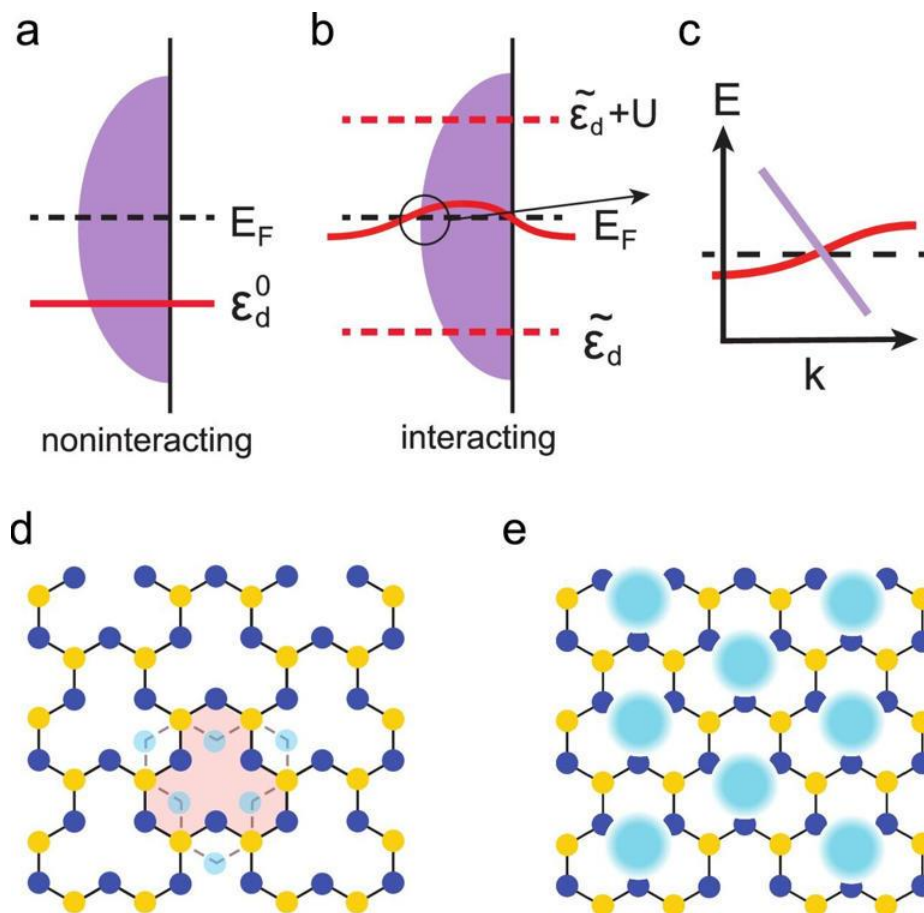

Illustration of the bare and emergent flat bands and lattice geometry. a In the noninteracting case, a flat band (red solid line) appears far away from the Fermi energy. b In the presence of orbital-selective correlations, an interaction-driven flat band emerges at the Fermi energy (red solid line), while leaving incoherent excitations far away from the Fermi energy (red dashed lines). c The emergent flat band crosses a dispersive band, leading to a topological Kondo semimetal with symmetry-protected Dirac/Weyl nodes that are pinned close to the Fermi energy, within an effective

Kondo energy scale. d Geometry of the clover lattice with 5 sublattices per unit cell. The lattice does not have inversion symmetry. This can be seen from the mismatch between the (dark) blue sublattices and their inversion counterparts (dots in light blue). e The Wannier orbitals are near the geometric centers (shaded blue circles) of the unit cells, which form a triangular lattice. Credit: Nature Communications (2024). DOI: 10.1038/s41467-024-49306-w© Provided by Phys.org

In a study [published](#) in *Nature Communications*, a team of scientists led by Rice University's Qimiao Si predicts the existence of flat electronic bands at the Fermi level, a finding that could enable new forms of quantum computing and electronic devices.

Quantum materials are governed by the rules of quantum mechanics, where electrons occupy unique energy states. These states form a ladder with the highest rung called the Fermi energy.

Electrons, being charged, repel each other and move in correlated ways. Si's team found that electron interactions can create new flat bands at the Fermi level, enhancing their importance.

"Most flat bands are located far from the Fermi energy, which limits their impact on the material's properties," said Si, the Harry C. and Olga K. Wiess Professor of Physics and Astronomy at Rice.

Typically, a particle's energy changes with its momentum. But in quantum mechanics, electrons can exhibit quantum interference, where their energy remains flat even when their momentum changes. These are known as flat bands.

"Flat electronic bands can enhance electron interactions, potentially creating new quantum phases and unusual low-energy behaviors," Si said.

These bands are especially sought after in transition metal ions called d-electron materials with specific crystal lattices, where they often show unique properties, Si said.

The team's findings suggest new ways to design these, which could inspire new applications for these materials in quantum bits, qubits and spintronics. Their research shows that electron interactions can link immobile and mobile electron states.

Using a theoretical model, the researchers demonstrated that these interactions can create a new type of Kondo effect, where immobile particles gain mobility by interacting with mobile electrons at the Fermi energy. The Kondo effect describes the scattering of conduction electrons in a metal due to magnetic impurities, resulting in a characteristic change in electrical resistivity with temperature.

"Quantum interference can enable the Kondo effect, allowing us to make significant progress," said Lei Chen, a Ph.D. student at Rice.

A key attribute of the flat bands is their topology, Chen said. "The flat bands pinned to the Fermi energy provide a means to realize new quantum states of matter," he said.

The team's research reveals that this includes anyons and Weyl fermions, or massless quasiparticles and fermions that carry an electric charge. The researchers found that anyons are promising agents for qubits, and materials that host Weyl fermions may find applications in spin-based electronics.

The study also highlights the potential for these materials to be very responsive to external signals and capable of advanced quantum control. The results indicate that the flat bands could lead to strongly correlated topological semimetals at relatively low temperatures, potentially operating at high temperatures or even room temperature.

"Our work provides the theoretical foundation for utilizing flat bands in strongly interacting settings to design and control novel quantum materials that operate beyond the realm of low temperatures," Si said.

Contributors to this research include Fang Xie and Shouvik Sur, Rice postdoctoral associates of physics and astronomy; Haoyu Hu, Rice alumnus and postdoctoral fellow at Donostia International Physics Center; Silke Paschen, physicist at the Vienna University of Technology; and Jennifer Cano, theoretical physicist at Stony Brook University and the Flatiron Institute.

As lasers go, those made of Titanium-sapphire (Ti:sapphire) are considered to have "unmatched" performance. They are indispensable in many fields, including

cutting-edge quantum optics, spectroscopy, and neuroscience. But that performance comes at a steep price. Ti:sapphire lasers are big, on the order of cubic feet in volume. They are expensive, costing hundreds of thousands of dollars each. And they require other high-powered lasers, themselves costing \$30,000 each, to supply them with enough energy to function.

As a result, Ti:sapphire lasers have never achieved the broad, real-world adoption they deserve—until now. In a dramatic leap forward in scale, efficiency, and cost, researchers at Stanford University have built a Ti:sapphire laser on a chip. The prototype is four orders of magnitude smaller (10,000x) and three orders less expensive (1,000x) than any Ti:sapphire laser ever produced.

"This is a complete departure from the old model," said Jelena Vučković, the Jensen Huang Professor in Global Leadership, a professor of electrical engineering, and senior author of the paper introducing the chip-scale Ti:sapphire laser [published](#) in the journal *Nature*.

"Instead of one large and expensive laser, any lab might soon have hundreds of these valuable lasers on a single chip. And you can fuel it all with a green laser pointer."

Profound benefits

"When you leap from tabletop size and make something producible on a chip at such a low cost, it puts these powerful lasers in reach for a lot of different important applications," said Joshua Yang, a doctoral candidate in Vučković's lab and co-first author of the study along with Vučković's Nanoscale and Quantum Photonics Lab colleagues, research engineer Kasper Van Gasse and postdoctoral scholar Daniil M. Lukin.

In technical terms, Ti:sapphire lasers are so valuable because they have the largest "gain bandwidth" of any laser crystal, explained Yang. In simple terms, gain bandwidth translates to the broader range of colors the laser can produce compared to other lasers. It's also ultrafast, Yang said. Pulses of light issue forth every quadrillionth of a second.

But Ti:sapphire lasers are also hard to come by. Even Vučković's lab, which does cutting-edge quantum optics experiments, only has a few of these prized lasers to share. The new Ti:sapphire laser fits on a chip that is measured in square millimeters. If the researchers can mass-produce them on wafers, potentially thousands, perhaps tens-of-thousands of Ti:sapphire lasers could be squeezed on a disk that fits in the palm of a human hand.

"A chip is light. It is portable. It is inexpensive and it is efficient. There are no moving parts. And it can be mass-produced," Yang said. "What's not to like? This democratizes Ti:sapphire lasers."

How it's done

To fashion the new laser, the researchers began with a bulk layer of Titanium-sapphire on a platform of silicon dioxide (SiO_2), all riding atop true sapphire crystal.

They then grind, etch, and polish the Ti:sapphire to an extremely thin layer, just a few hundred nanometers thick. Into that thin layer, they then pattern a swirling vortex of tiny ridges. These ridges are like fiber-optic cables, guiding the light around and around, building in intensity. In fact, the pattern is known as a waveguide.

"Mathematically speaking, intensity is power divided by area. So, if you maintain the same power as the large-scale laser, but reduce the area in which it is concentrated, the intensity goes through the roof," Yang says. "The small scale of our laser actually helps us make it more efficient."

The remaining piece of the puzzle is a microscale heater that warms the light traveling through the waveguides, allowing the Vučković team to change the wavelength of the emitted light to tune the color of the light anywhere between 700 and 1,000 nanometers—in the red to infrared.

Spotlight on applications

Vučković, Yang, and colleagues are most excited about the range of fields that such a laser might impact. In quantum physics, the new laser provides an inexpensive and practical solution that could dramatically scale down state-of-the-art quantum computers.

In neuroscience, the researchers can foresee immediate application in optogenetics, a field that allows scientists to control neurons with light guided inside the brain by relatively bulky optical fiber. Small-scale lasers, they say, might be integrated into more compact probes opening up new experimental avenues.

In ophthalmology, it might find new use with Nobel Prize-winning chirped pulse amplification in laser surgery or offer less expensive, more compact optical coherence tomography technologies used to assess retinal health.

Next up, the team is working on perfecting their chip-scale Ti:sapphire laser and on ways to mass-produce them, thousands at a time, on wafers. Yang will earn his doctorate this summer based on this research and is working to bring the technology to market.

"We could put thousands of lasers on a single 4-inch wafer," Yang says. "That's when the cost per laser starts to become almost zero. That's pretty exciting."

More information: Jelena Vučković, Titanium:sapphire-on-insulator integrated lasers and amplifiers, *Nature* (2024). [DOI: 10.1038/s41586-024-07457-2](https://doi.org/10.1038/s41586-024-07457-2). www.nature.com/articles/s41586-024-07457-2

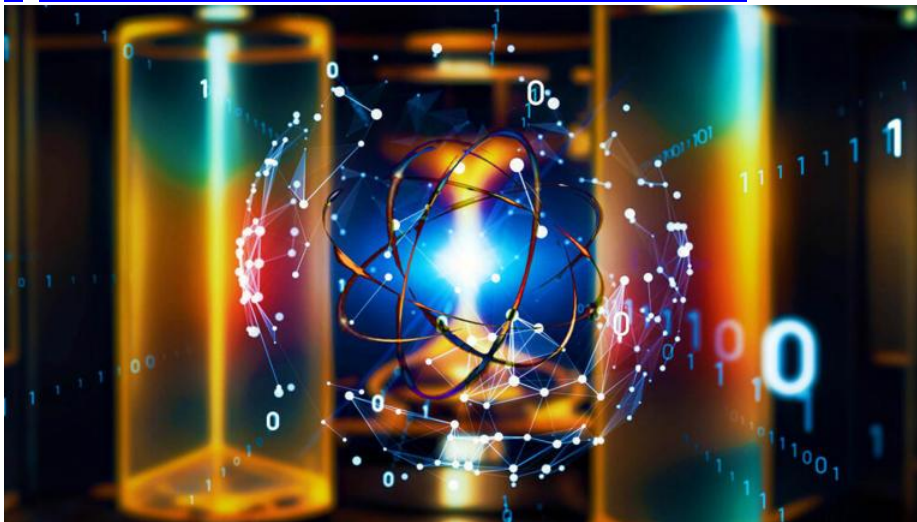

How the quantum revolution will impact all aspects of society© Provided by Earth

In the bizarre realm of quantum physics, a quiet revolution is taking place, where the impossible becomes possible.

[Electrons spin](#) both right and left simultaneously, and particles [change states in unison](#) despite vast distances separating them.

These intriguing phenomena are commonplace in the quantum world, and researchers are harnessing their power to revolutionize computing, sensing, and communication.

Cooling chips for quantum computing

At the Walther Meissner Institute ([WMI](#)) on the [TUM Garching](#) research campus, Professor Rudolf Gross and his team are pushing the boundaries of quantum technology.

"We cool the chip down to only a few thousandths of a degree above absolute zero -- colder than in outer space," explains Gross, gesturing towards a delicate device with gold-colored disks connected by cables.

For two decades, WMI researchers have been working on quantum computers, a technology that emerged from the [quantum physics](#) revolution a century ago. Today, this field serves as the foundation for what Gross calls a "new era of technology."

Quantum revolution seen in everyday technology

"We encounter quantum physics every day," says Gross, citing the example of a glowing red stovetop burner.

Max Planck's discovery of quanta in 1900 fundamentally changed our understanding of the microcosmos, paving the way for technologies like lasers, MRI machines, and [computer chips](#).

While the first quantum revolution controlled large numbers of particles, the second quantum revolution focuses on manipulating individual [atoms](#) and [photons](#).

"Today we can create tailor-made quantum systems," says Gross, leveraging principles like superposition, quantum interference, and entanglement.

[Classical computers](#) process information sequentially, limiting their ability to solve complex problems efficiently. [Quantum computers](#), however, use quantum bits (qubits) that can process 0 and 1 simultaneously, enabling parallel processing and quick solutions to highly complex tasks.

"Not even supercomputers which are constantly growing faster will be able to master all the tasks at hand," says Gross, highlighting the potential of quantum computing to tackle problems that become overwhelmingly complex for classical computers.

What are qubits?

Qubits, or quantum bits, are the fundamental units of information in quantum computing. They represent the quantum equivalent of classical bits, which are used in traditional computing.

However, qubits possess unique properties that make them vastly different from their classical counterparts.

One of the most remarkable features of qubits is their ability to exist in a state of superposition. While classical bits can only be in one of two states (0 or 1) at any given time, qubits can simultaneously exist in multiple states.

This means that a qubit can represent a combination of both 0 and 1 at the same time, allowing for complex computations to be performed in parallel.

Entanglement: The power of qubits

Another essential property of qubits is entanglement. When two or more qubits are entangled, they become intrinsically linked, regardless of the physical distance between them.

This entanglement allows for instantaneous communication and correlation between the qubits, enabling quantum computers to perform certain calculations exponentially faster than classical computers.

To harness the power of qubits, researchers and engineers are developing sophisticated quantum circuits and algorithms. These circuits manipulate the states of qubits through a series of quantum gates, allowing for the execution of complex quantum operations.

By carefully controlling and measuring the states of qubits, quantum computers can solve problems that are intractable for classical computers, such as factoring large numbers, simulating complex molecules, and optimizing complex systems.

Reducing errors and increasing stability

[Quantum computers](#) need hundreds of qubits to solve practical problems, but qubits are prone to losing their superposition due to disturbances like material defects or electrosmog.

Complex error correction procedures require thousands of additional [qubits](#), a challenge that experts expect will take years to overcome.

Dr. Kirill Fedorov of the WMI proposes distributing qubits across several chips and entangling them to reduce errors.

"One important error source is unwanted mutual interaction between qubits," he explains, suggesting that this approach could enable thousands of qubits to work together in the future.

Quantum sensors: Sensitivity into precision

"The fact that quantum states react so sensitively to everything can also be an advantage," says Professor Eva Weig, a pioneer in the field of [nano and quantum sensor](#) technology.

She believes that this inherent sensitivity of quantum systems can be harnessed to create a new generation of highly precise and responsive sensors by leveraging the way quantum states are altered.

Weig envisions the development of quantum sensors capable of detecting minute changes in magnetic fields, pressure, temperature, and other physical parameters with unprecedented accuracy and spatial resolution.

Weig's team is working on "nano-guitars," tiny strings 1,000 times thinner than a human hair that vibrate at radio frequency.

By putting these nano-oscillators into a defined quantum state, they could be used as [quantum sensors](#) to measure forces between individual cells.

Internet revolution from quantum technology

Professor Andreas Reiserer is exploring quantum cryptography, which relies on the principle that measuring a particle's quantum state destroys the information it contains. "Quantum cryptography is cost-effective and can already support interception-proof communication today," he says.

However, the scope of this technology is limited by the absorption of light in fiber optic cables. Reiserer's team is researching quantum repeaters, storage units for [quantum information](#) spaced along fiber optic networks, to enable long-distance quantum communication.

"This way we hope to be able to traverse global-scale distances," Reiserer says, envisioning a future where devices worldwide could be linked to form a "quantum supercomputer."

As quantum technologies become more prevalent, it's crucial to consider their ethical, legal, and societal implications. Professor Urs Gasser, head of the Quantum Social Lab at TUM, warns that the cost of arriving too late to the quantum revolution could outstrip the cost of being late on [artificial intelligence](#).

"The good news is that there are already new encryption procedures which are secure against quantum computer attacks," says Gasser, stressing the need to start preparing for the transition now.

Gasser emphasizes the far-reaching impact of the quantum revolution, stating, "The second quantum revolution is a paradigm shift which will have a far-reaching social, political and economic impact. We have to shape this revolution in the best interests of society."

Human evolution and the quantum realm

In summary, as researchers at the Garching research campus lead the charge in harnessing the bizarre phenomena of quantum physics, the potential applications of quantum technology are vast and far-reaching.

From [quantum computers](#) that can solve complex problems in a fraction of the time to quantum sensors that offer unparalleled precision and sensitivity, the future is undeniably quantum.

However, as we embrace this new era of innovation, we must also consider the ethical, legal, and societal implications of these advancements.

By actively shaping the quantum revolution with the best interests of society in mind, we can ensure that the benefits of these technologies are widely accessible and that their impact is overwhelmingly positive.

The full study was published by the [Technical University of Munich](#).

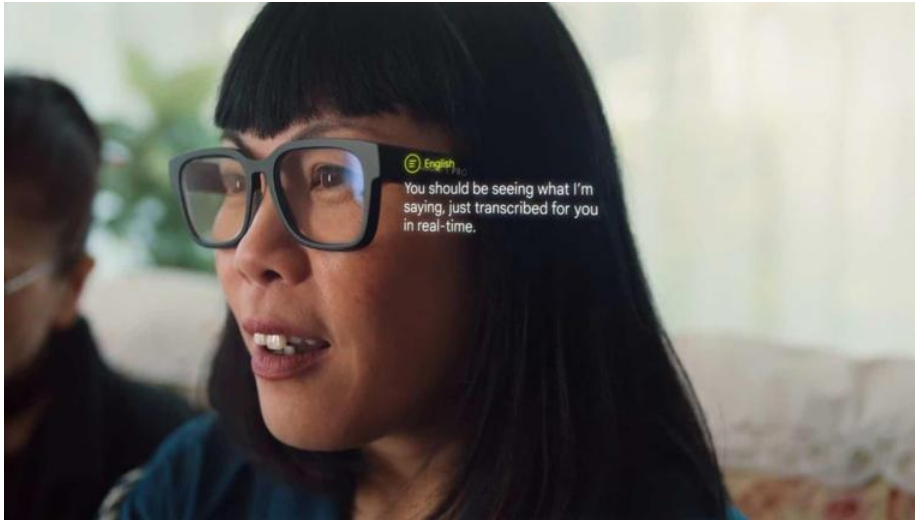

Google IO 2022 smart glasses prototype© Provided by Android Headlines

Science fiction has been the cradle of multiple ideas that today are reality, while others seem much more possible than before. Until relatively recently, a decent VR experience was impossible or very cumbersome to enjoy. Another advanced technology that seems more viable today is AR glasses that replace your phone, and [Apple](#) would be looking for it.

According to Bloomberg, Apple is [restarting](#) a project to develop advanced AR glasses. These would be much [lighter](#) than the [Apple Vision Pro](#), whose ergonomics are not its best virtue. However, the company would like you to be able to use the glasses all day, so they would have fairly contained dimensions. Its format would be similar to that of the [Google Glass](#) project from years ago.

Apple's AR glasses could fully replace your iPhone

Apple already boasts of having a lot of experience in AR-based UX thanks to the development of the Vision Pro. According to the report, some of the Vision Pro technologies would be implemented in the lightweight AR glasses. Internally, a release date of 2027 has even been discussed. However, the source adds that even the development team sees that deadline as unlikely.

Apple has yet to decide whether to invest in everything that a project of this magnitude requires. The company must study the profitability that AR glasses capable of replacing iPhones would bring. So, they must consider key items such as development cost, public interest, and price for the user, among others. The company will surely be quite cautious after the [failure in sales](#) of its Vision Pro.

Apple has yet to decide on the viability of the project

Vision Products Group is the team in charge of all the company's "Vision" projects. Recent reports suggest that they are focusing on a more [affordable Vision headset](#). Bloomberg claims that the team will decide on the viability of AR glasses as they work on other things.

In its day, the Google Glass project had many factors that influenced [its failure](#). Probably the most important factor was the starting price of \$1,500. However, there were also serious regulatory challenges due to its video recording capabilities. It will be interesting to see if potential Apple AR glasses manage to overcome these challenges in the future.

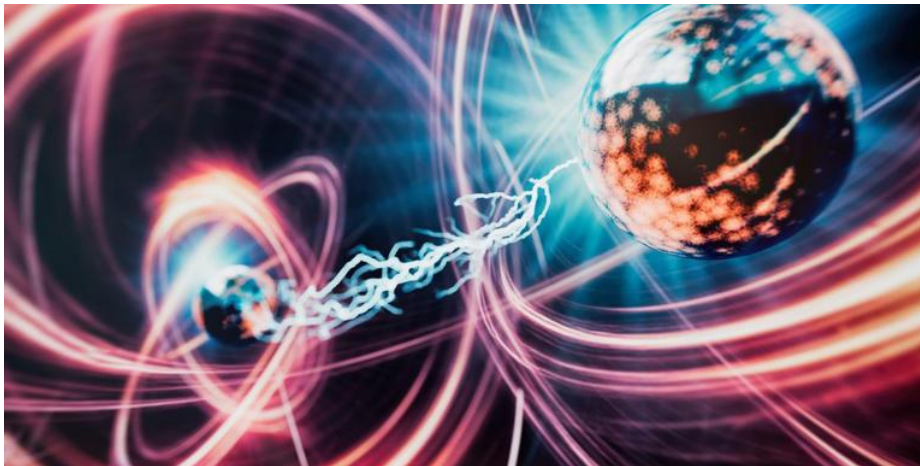

The top quark also experiences quantum entanglement, according to new discoveries by CERN.© koto_feja - Getty Images

- Discovered in 1995, the top quark is the most massive elementary particle that exists, outweighing even the Higgs boson.

- Because of its atypical size as compared to other quarks, scientists were curious if it experienced quantum entanglement like other particles.
- Now, ATLAS and CMS experiments at CERN's Large Hadron Collider have both discovered entanglement among top quarks, and this discovery could help unravel more mysteries about this incredible "spooky action at a distance."

At its bare essentials, every atom is made of two fundamental particles: electrons and quarks. But not all quarks are the same. In fact, [the Standard Model of Physics](#)—molded of the course of a half-century—identifies six different kinds, including up, down, strange, charm, bottom, and top quarks. Scientists discovered the top quark only some 30 years ago, and was the last piece of the quark puzzle. That's because unlike the other quarks, the top quark is *big* compared to its subatomic brethren.

Top quarks weigh in at an impressive 175.6 gigaelectron volts (GeV)—about the same [mass](#) of the atomic nucleus of gold—but only exist for 15 to 24 seconds before decaying into free particles. Because of the top quark's (relatively) massive bulk, it took decades after the discovery of the bottom quark for the U.S.-based Fermilabs to create an accelerator [capable of detecting the elusive particle](#).

In the 30 years since, investigating the top quark has opened up new worlds of particle physics, and the discovery of the [Higgs boson](#) in 2012 revealed the two particles' close association. Now, scientists at [CERN](#) have been busy investigating the top quark's quantum properties, and discovered that top quarks experience quantum entanglement like other elementary particles even in spite of their mass.

In the fall of 2023, the [Toroidal LHC Apparatus \(ATLAS\) Experiment](#) discovered entanglement between two top quarks, and earlier this week, another CERN detector—the Compact Muon Solenoid (CMS)—also detected [quantum entanglement](#) between top quarks, [according to CERN](#). Specifically, the team discovered entanglement between the unstable top quark and its antimatter partner across distances "farther than what can be covered by information transferred at the speed of light," according [to a press release](#). In the famous words of Albert Einstein, that is what's known as "[spooky action at distance](#)."

To help illustrate this strange effect of [quantum mechanics](#), Regina Demina from the University of Rochester—who was part of the original team that discovered the top quark in 1995, co-lead a team that built the tracking device for finding the Higgs boson, and now led the CMS team at the Large Hadron Collider at CERN—describes the idea in colorful terms [via a Facebook video](#):

“In a faraway land, there was a king. His name was Top, and he got the news that his country is being invaded by his enemy. So, he sends messengers to tell his constituents to defend, but then he has a bad dreams, and he changes his decision. And again, he sends messengers to tell his decision. He keeps flip-flopping like this and no one knows what his decision will be at the next moment. But there is one village that actually happens to know his decision, every time, perfectly. The king of this village is Anti-Top. These are the particles that we’re dealing with: They know each other’s state of mind at any given time.”

This kind of entanglement has been a hot topic when it comes to exploring quantum information and [quantum computers](#), but top quarks can only be made in colliders. So, while they won’t be used in these types of next-gen machines, the discovery of their entanglement could answer questions about this the nature of this “spooky action from a distance”—questions like whether that entanglement continues once a particle decays, and what eventually breaks that entanglement.

It’s been a long journey of discovery when it comes to the top quark, and there are likely many more [mysteries](#) yet to uncover.

These hidden forces may reshape our approach to particle physics.© Yana Iskayeva - Getty Images

- Although the periodic table is filled with elements, nuclear fusion at the center of stars can only produce elements with atomic masses lower

than iron—after that, neutron capture processes known as r-process and s-process produce the rest.

- However, for nearly 50 years, scientists have theorized a third process, known as intermediate neutron-capture process (i-process) that falls somewhat between these two processes, and recently astrophysicists have revived the idea to explain strange mysteries around carbon-enhanced metal-poor stars.
- Now a study from the University of Wisconsin-Madison dives into the quantum physics of this i-process and discovers that it's possible through neutrino-neutrino entanglement.

In the beginning, there was lots and *lots* of hydrogen and helium—that is until the fiery fusion furnaces of primordial stars began churning out heavier elements. Nuclear fusion can form elements all the way until an atom contains 26 protons and 30 neutrons (aka Iron) until it inevitably collapses. Of course, there's just one problem. If you've happened to glance at a periodic table lately, there's many more elements with atomic masses far beyond iron. So what gives?

Turns out there's another element-producing process at work, and it's called neutron capture, or nucleosynthesis. This process breaks down into two different types, which are called rapid neutron-capture process (r-process) and slow neutron-capture process (s-process), and each are roughly responsible for creating half of the known elements beyond iron. As their names suggest, these processes occur in very different environments. R-process requires a high density of free neutrons (think neutron star mergers or supernova collapses) while s-process occurs in asymptotic giant branch (AGB) stars and [possible metal-poor massive stars](#) via radioactive decay.

But as with most things in astrophysics, things are not quite so black and white. Back in 1977, scientists proposed a third process, known as the intermediate-process (i-process), that exists sort of in between both r- and s-processes. The idea faded with time but has regained attention in recent years due to the enigma known as [carbon-enhanced metal-poor \(CEMP\) r/s stars](#), which produce abundances of carbon and heavy elements associated with *both* processes. Now, [a new study from the University of Wisconsin—Madison](#) investigates how

exactly such an i-process would work, and the solution to this very big mystery veers into the very small quantum world.

“When a supernova collapse occurs, you start with a big star, which is gravitationally bound, and that binding has energy,” UW-Madison’s Baha Balantekin, a co-author of a paper on the i-process published in [*The Astrophysical Journal*](#), said in a press statement. While the i-process is a nucleosynthesis middle child, one aspect it shares with r-process is that it only occurs in similarly violent conditions. “When it collapses, that energy has to be released, and it turns out that energy is released in neutrinos.”

It’s when those neutrinos experience quantum entanglement due to interactions in a supernova, that the i-process can take over and produce heavy elements. This entanglement means the two neutrinos “remember” each other no matter how far apart they may be. Using well-known rates of neutron capture, catalogs of atomic spectra of various stars, and data surrounding neutrino production via supernova, the team ran simplified simulations (supernovae produce 10^{58} neutrinos after all) and arrive at differing abundances depending on whether these neutrinos were entangled or not.

“We have a system of, say, three neutrinos and three antineutrinos together in a region where there are protons and neutrons and see if that changes anything about element formation,” Balantekin says. “We calculate the abundances of elements that are produced in the star, and you see that the entangled or not entangled cases give you different abundances.”

There are a few things about this hypothesis that still need to be tested—chief among them is that neutrino-neutrino interactions are largely hypothetical at this point. However, this new process could help further explain how something came from nothing.

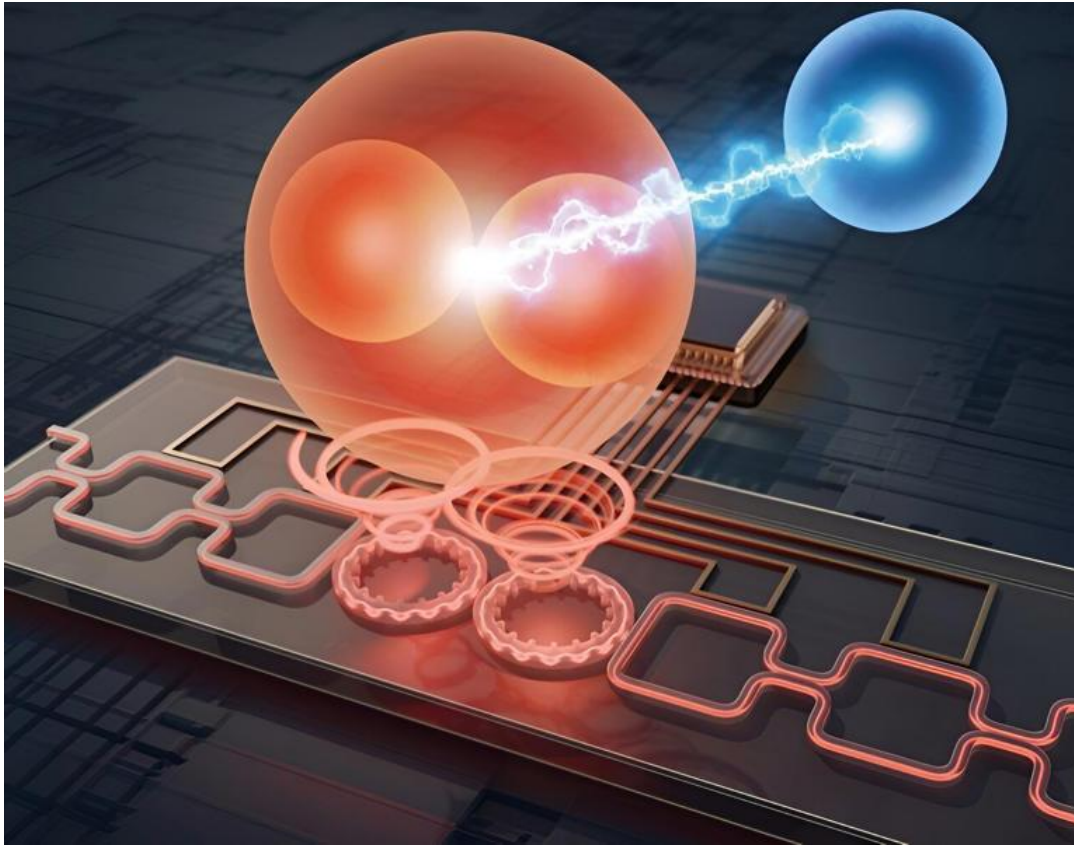

(a) The experimentally retrieved (upper row) and theoretically predicted (lower row) density matrices of two selected quantum states. (b) Theoretically (left panel) and experimentally retrieved (right panel) probability-of-detection matrix. Credit: Chinese Academy of Sciences© Provided by Phys.org

Scientists have made a significant breakthrough in creating a new method for transmitting quantum information using particles of light called qudits. These qudits promise a future quantum internet that is both secure and powerful. The study is [published](#) in the journal *eLight*.

Traditionally, quantum information is encoded on qubits, which can exist in a state of 0, 1, or both at the same time (superposition). This quality makes them ideal for complex calculations but limits the amount of data they can carry in communication. Conversely, qudits can encode information in higher dimensions, transmitting more data in a single go.

The new technique harnesses two properties of light—spatial mode and polarization—to create four-dimensional qudits. These qudits are built on a

special chip that allows for precise manipulation. This manipulation translates to faster data transfer rates and increased resistance to errors compared to conventional methods.

One of the key advantages of this approach is the qudits' ability to maintain their quantum properties over long distances. This makes them perfect for applications like satellite-based quantum communication, where data needs to travel vast distances without losing its integrity.

The process starts with generating a special entangled state using two photons. Entanglement is a phenomenon where two particles become linked, sharing the same fate regardless of physical separation.

In this case, one photon (the signal photon) is manipulated on the chip to create a 4D qudit using its spatial mode and polarization. The other photon (idler photon) remains unchanged and acts as a remote control for the signal photon. By manipulating the idler photon, scientists can control the state of the signal photon and encode information onto it.

This new method has the potential to revolutionize the field of quantum communication. It paves the way for a high-speed quantum internet that can transmit massive amounts of data securely over long distances.

Additionally, it can lead to the development of unbreakable encryption protocols and contribute to the creation of powerful quantum computers capable of tackling problems beyond the reach of classical computers.

The researchers are currently focusing on improving the accuracy of the qudits and scaling up the technology to handle even higher dimensions.

More information: Haoqi Zhao et al, Integrated preparation and manipulation of high-dimensional flying structured photons, *eLight* (2024). [DOI: 10.1186/s43593-024-00066-6](https://doi.org/10.1186/s43593-024-00066-6)

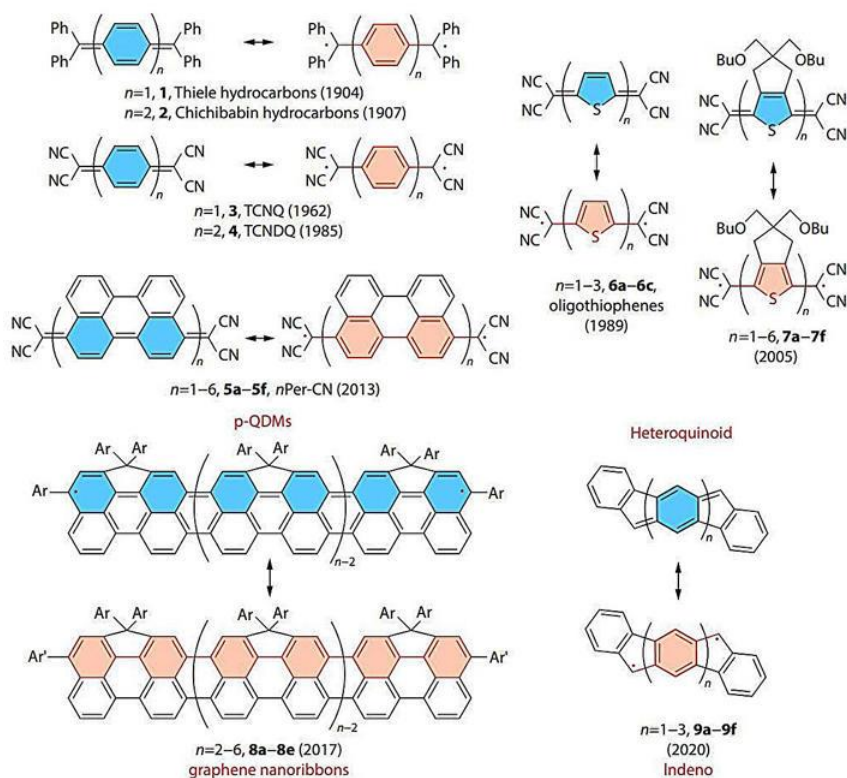

Quinone-based oligomers and polymers derived from p-QDMs, Heteroquinoids, indeno, and graphene nanoribbons exhibiting triplet ground states or thermally accessible triplet states. Credit: Chinese Journal of Polymer Science (2024). DOI: 10.1007/s10118-024-3087-7© Provided by Phys.org

The study of open-shell molecules, particularly those with high-spin ground states, has unveiled significant potential in organic electronics and magnetism. These molecules, characterized by unpaired electrons, exhibit unique properties such as long spin lifetimes and weak spin-orbit coupling, making them promising candidates for advanced technologies.

However, the design and synthesis of stable open-shell polymers pose considerable challenges due to their thermodynamic and kinetic instability. Based on these challenges, further in-depth research is essential to develop effective strategies for their design, synthesis, and application in high-performance electronic and magnetic devices.

A [recent review](#) by researchers at Peking University, published on January 25, 2024, in the *Chinese Journal of Polymer Science*, provides a comprehensive overview of open-shell oligomers and polymers.

The review highlights the theory, characterization methods, molecular design, and potential applications of these materials, underscoring their significance in advancing electronic and magnetic technologies.

The review provides a detailed examination of open-shell conjugated polymers, focusing on their theoretical foundations and characterization techniques. It covers the basic theory of diradicals and polyradicals and explores computational methods like quantum chemical calculations, as well as experimental approaches such as electron paramagnetic resonance (EPR) spectroscopy and superconducting quantum interference device (SQUID) magnetometry.

The authors categorize open-shell polymers into quinoidal types and quinoidal-aromatic alternating copolymers, emphasizing their distinctive properties and potential applications. High-spin polymers based on donor-acceptor structures are highlighted for their remarkable stability, processability, and suitability for optoelectronic and spintronic devices.

The review also discusses the challenges in achieving high-spin states while maintaining desired optoelectronic performance, offering insights into future research directions to overcome these obstacles and enhance the practical application of open-shell polymers.

Dr. Ting Lei, senior author on the study, stated, "The advancements in the design and characterization of open-shell conjugated polymers mark a significant step forward in the development of next-generation electronic and magnetic devices. These materials' unique properties offer immense potential for various high-tech applications, from flexible electronics to quantum computing."

The potential applications of open-shell conjugated polymers are vast, spanning from organic field-effect transistors (OFETs) and photodetectors to organic thermoelectrics and spintronics. Their unique electronic and magnetic properties, combined with improved stability and processability, make them ideal candidates for future technologies.

Continued research and development in this field could lead to significant advancements in electronic and magnetic device performance, opening new avenues for innovation in various industries.

More information: Xue-Qing Wang et al, Open-Shell Oligomers and Polymers: Theory, Characterization Methods, Molecular Design, and Applications, *Chinese Journal of Polymer Science* (2024). DOI: [10.1007/s10118-024-3087-7](https://doi.org/10.1007/s10118-024-3087-7)

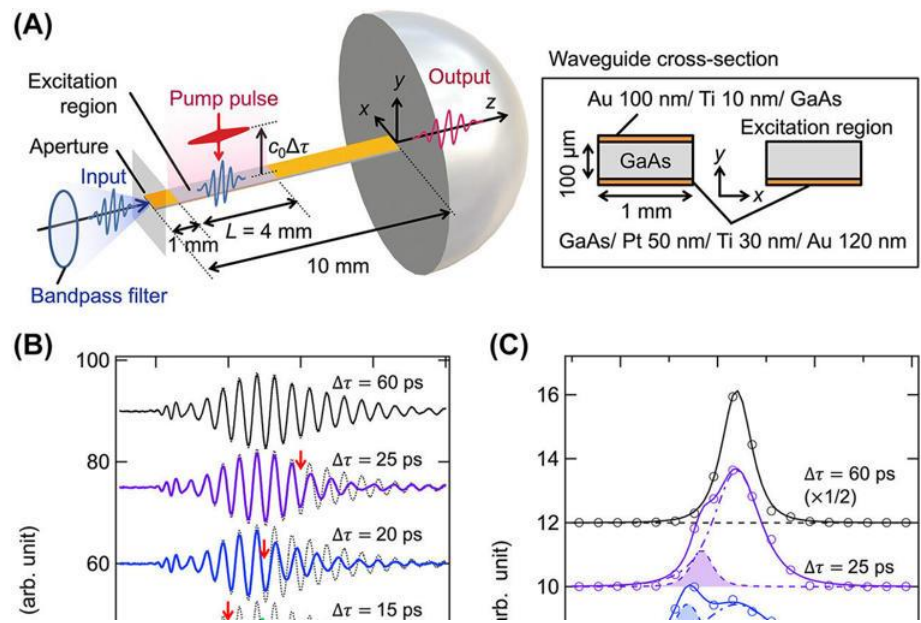

Experimental setup and observed terahertz waves. Credit: Nanophotonics (2024). DOI: 10.1515/nanoph-2024-0010 © Provided by Phys.org

Terahertz technology could help us meet the ever-increasing demand for faster data transfer rates. However, the down-conversion of a terahertz signal to arbitrary lower frequencies is difficult.

In a recent study, researchers from Japan have developed a new strategy to up- and down-convert a terahertz signal in a waveguide by dynamically modifying its conductivity using light, creating a temporal boundary. Their findings could pave the way to faster and more efficient optoelectronics and enhanced telecommunications.

As we plunge deeper into the Information Age, the demand for faster data transmission keeps soaring, accentuated by fast progress in fields like deep learning and robotics. Against this backdrop, more and more scientists are exploring the potential of using terahertz waves to develop high-speed telecommunication technologies.

However, to use the terahertz band efficiently, we need frequency division multiplexing (FDM) techniques to transmit multiple signals simultaneously. Of course, being able to up-convert or down-convert the frequency of a terahertz signal to another arbitrary frequency is a logical prerequisite to FDM. This has unfortunately proven quite difficult with current technologies.

The main issue is that terahertz waves are extremely high-frequency waves from the viewpoint of conventional electronics and very low-energy light in the context of optics, exceeding the capabilities of most devices and configurations across both fields. Therefore, a radically different approach will be needed to overcome current limitations.

Surprisingly, in a study [published in *Nanophotonics*](#) on May 20, 2024, a research team including Assistant Professor Keisuke Takano from the Faculty of Science, Shinshu University, Japan, report an innovative solution for the frequency down-conversion of terahertz waves.

Their paper was co-authored by Fumiaki Miyamaru from Shinshu University, Toshihiro Nakanishi from Kyoto University, Yosuke Nakata from Osaka University, and Joel Pérez-Urquizo, Julien Madéo, and Keshav M. Dani from Okinawa Institute of Science and Technology.

The proposed strategy is based on the frequency conversions that occur in time-varying systems. Much like a waveguide confines a traveling wave packet in space, there is an analogous concept that occurs in time known as temporal waveguiding. Simply put, variations that occur across an entire system over time will act as a "temporal boundary."

Similar to spatial boundaries (e.g., the interface between two different mediums), temporal boundaries can alter the dispersion properties of the waveguide, giving rise to different propagation modes at new frequencies.

To create this temporal boundary, the researchers first laid out a GaAs waveguide over a thin metallic layer. As terahertz waves traveled through the waveguide in the transverse magnetic (TM) mode, they shined a light on the bare GaAs surface. The resulting photoexcitation of the top surface instantaneously altered its conductivity, effectively turning the bottom-metalized waveguide into a parallel double-metalized waveguide.

This transition from one waveguide structure to another acted as the temporal boundary, at which the incident TM modes of the bare waveguide coupled with the transverse electromagnetic (TEM) mode of the double-metalized waveguide. Given that the dispersion curve of the TEM mode occupies a lower frequency range than that of the incident TM mode, this approach produces a frequency-down-shifted terahertz wave.

The research team ran experiments that ultimately validated their thorough theoretical analysis of the proposed frequency conversion method. Thus, the findings of this study paint a bright future for upcoming terahertz technology.

Dr. Takano says, "Frequency conversion devices for terahertz waves have the potential to be applied to future ultra-high-speed wireless communications. For example, they could enable information replication between terahertz wave frequency channels carrying different data. There may also be devices where terahertz wave information processing circuits are integrated with various optical processing components."

Worth noting, up-conversion through the proposed approach was [also demonstrated](#) in a *Physical Review Letters* paper. Moreover, the up- and down-conversion can be switched by manipulating the polarization of the input terahertz waves, which would help make FDM in the terahertz range more convenient.

To top this off, the present frequency conversion method is not strictly limited to terahertz waveguides and could also have important implications in optics.

"It is important to recognize that the concept of this study extends beyond the terahertz frequency range and can be applied to the optical frequency range as well. Ultrafast frequency conversion devices comprising optically modulated waveguides with indium tin oxide may also be possible, based on recent findings," said Dr. Takano.

Further developments in this field could ultimately lead to faster and more energy-efficient telecommunications, helping us build a more interconnected and sustainable society.

More information: Keisuke Takano et al, Frequency down-conversion of terahertz waves at optically induced temporal boundaries in GaAs waveguides, *Nanophotonics* (2024). DOI: [10.1515/nanoph-2024-0010](https://doi.org/10.1515/nanoph-2024-0010)

A group of researchers from the [Pohang University of Science and Technology](#) and the National Institute for Materials Science have successfully controlled the quantum mechanical properties of Andreev-bound states in bilayer graphene-based Josephson junctions using gate voltage. The research was published in the journal *Physical Review Letters*.

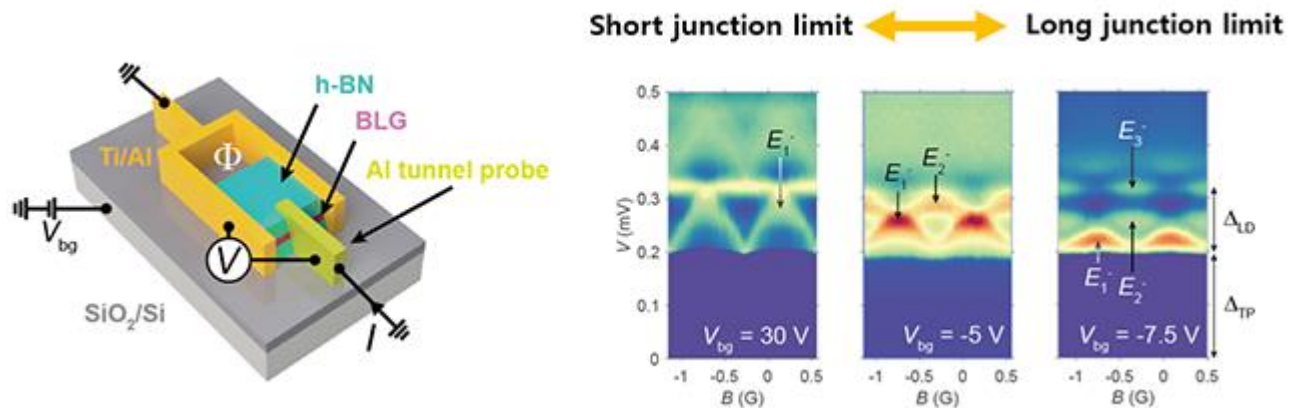

(Left) A schematic of a bilayer graphene Josephson junction device with a tunneling electrode. (Right) Variation of the number of energy levels of Andreev bound states for different gate voltages. Image Credit: Pohang University of Science and Technology© Provided by AZoQuantum

Professors Gil-Ho Lee and Gil Young Cho from the Department of Physics at Pohang University of Science and Technology (POSTECH) in South Korea, in collaboration with Dr. Kenji Watanabe and Dr. Takashi Taniguchi from the National Institute for Materials Science (NIMS) in Japan, carried out the research.

Related Stories

Superconductors are substances that show zero electrical resistance in some circumstances, such as at very low temperatures or high pressures. The proximity effect, in which superconductivity extends into the normal conductor, causes a

supercurrent to flow through a very thin normal conductor between two superconductors.

This apparatus is referred to as a Josephson junction. Andreev-bound states are novel quantum states that arise within the normal conductor and play a critical role in mediating the supercurrent flow.

The ratio of the “conduction channel length” (the length of the normal conductor) to the “superconducting coherence length” (the length along which the superconducting state can be maintained in the normal conductor) determines the number of energy levels in the Andreev bound states, which determines the electrical properties of a Josephson junction.

The system is said to be in the “short junction limit” when the conduction channel is short, and there are only two Andreev-bound state levels. On the other hand, the term “long junction limit” is used when there are more than two pairs.

In this work, the researchers employed gate voltage to regulate time, both the superconducting coherence length and the quadratic energy dispersion of bilayer graphene. They observed the changing of the Andreev bound states at various gate voltages in real time using tunneling spectroscopy, which they created in their prior work, and they verified that the experimental results matched theoretical expectations.

We have observed the Andreev bound states in the long Josephson junction limit, a phenomenon predominantly seen in the short Josephson junction limit. We anticipate that the number of energy levels can be readily adjusted by applying gate voltage alone, offering potential applications in diverse fields such as quantum computing and high-precision quantum sensors.

Geon-Hyoung Park, Study Lead Author and Researcher, Quantum Information Device Research and Education Center, Pohang University of Science and Technology

The research was funded by the National Research Foundation of Korea, the Ministry of Science and ICT, the ITRC, the Air Force Office of Scientific Research, the Institute for Basic Science (IBS), the Samsung Future Technology Incubation Program, Samsung Electronics, the Basic Science Research Institute, the JSPS KAKENHI, and the World Premier International Research Center Initiative (WPI).

Journal Reference:

Park, G.-H., *et al.* (2024) Andreev Bound States in Bilayer Graphene Josephson Junctions from Short to Long Junction Limits. *Physical Review Letters*. doi.org/10.1103/physrevlett.132.226301.

The device uses a simple electric diode to manipulate qubits inside a commercial silicon wafer. Credit: Second Bay Studios/Harvard SEAS© Provided by Phys.org

The quantum internet would be a lot easier to build if we could use existing telecommunications technologies and infrastructure. Over the past few years, researchers have discovered defects in silicon—a ubiquitous semiconductor material—that could be used to send and store quantum information over widely used telecommunications wavelengths. Could these defects in silicon be the best choice among all the promising candidates to host qubits for quantum communications?

"It's still a Wild West out there," said Evelyn Hu, the Tarr-Coyne Professor of Applied Physics and of Electrical Engineering at the Harvard John A. Paulson School of Engineering and Applied Sciences (SEAS).

"Even though new candidate defects are a promising quantum memory platform, there is often almost nothing known about why certain recipes are used to create them, and how you can rapidly characterize them and their interactions, even in ensembles.

"And ultimately, how can we fine-tune their behavior so they exhibit identical characteristics? If we are ever to make a technology out of this wide world of possibilities, we must have ways to characterize them better, faster and more efficiently."

Now, Hu and a team of researchers have developed a platform to probe, interact with and control these potentially powerful quantum systems. The device uses a simple electric diode, one of the most common components in semiconductor chips, to manipulate qubits inside a commercial silicon wafer.

Using this device, the researchers were able to explore how the defect responds to changes in the electric field, tune its wavelength within the telecommunications band and even turn it on and off.

"One of the most exciting things about having these defects in silicon is that you can use well-understood devices like diodes in this familiar material to understand a whole new quantum system and do something new with it," said Aaron Day, a Ph.D. candidate at SEAS. Day co-led the work with Madison Sutula, a research fellow at Harvard.

While the research team used this approach to characterize defects in silicon, it could be used as a diagnostic and control tool for defects in other material systems.

The research is [published](#) in *Nature Communications*.

Quantum defects, also known as color centers or quantum emitters, are imperfections in otherwise perfect crystal lattices that can trap single electrons. When those electrons are hit with a laser, they emit photons in specific wavelengths.

The defects in silicon that researchers are most interested in for quantum communications are known as G-centers and T-centers. When these defects trap electrons, the electrons emit photons in a wavelength called the O-band, which is widely used in telecommunications.

In this research, the team focused on G-center defects. The first thing they needed to figure out was how to make them. Unlike other types of defects, in which an atom is removed from a crystal lattice, G-center defects are made by adding atoms to the lattice, specifically carbon. But Hu, Day and the rest of the research team found that adding hydrogen atoms is also critical to consistently forming the defect.

Next, the researchers fabricated electrical diodes using a new approach which optimally sandwiches the defect at the center of every device without degrading the performance of either the defect or the diode.

The fabrication method can create hundreds of devices with embedded defects across a commercial wafer. Hooking the whole device up to apply a voltage, or

electric field, the team found that when a negative voltage was applied across the device, the defects turned off and went dark.

"Understanding when a change in environment leads to a loss of signal is important for engineering stable systems in networking applications," said Day,

The researchers also found that by using a local electric field, they could tune the wavelengths being emitted by the defect, which is important for quantum networking when disparate quantum systems need to be aligned.

The team also developed a diagnostic tool to image how the millions of defects embedded in the device change in space as the electric field is applied.

"We found that the way we're modifying the electric environment for the defects has a spatial profile, and we can image it directly by seeing the changes in the intensity of light being emitted by the defects," said Day.

"By using so many emitters and getting statistics on their performance, we now have a good understanding of how defects respond to changes in their environment. We can use that information to inform how to build the best environments for these defects in future devices. We have a better understanding of what makes these defects happy and unhappy."

Next, the team aims to use the same techniques to understand the T-center defects in silicon.

More information: Aaron M. Day et al, Electrical manipulation of telecom color centers in silicon, *Nature Communications* (2024). [DOI: 10.1038/s41467-024-48968-w](https://doi.org/10.1038/s41467-024-48968-w)

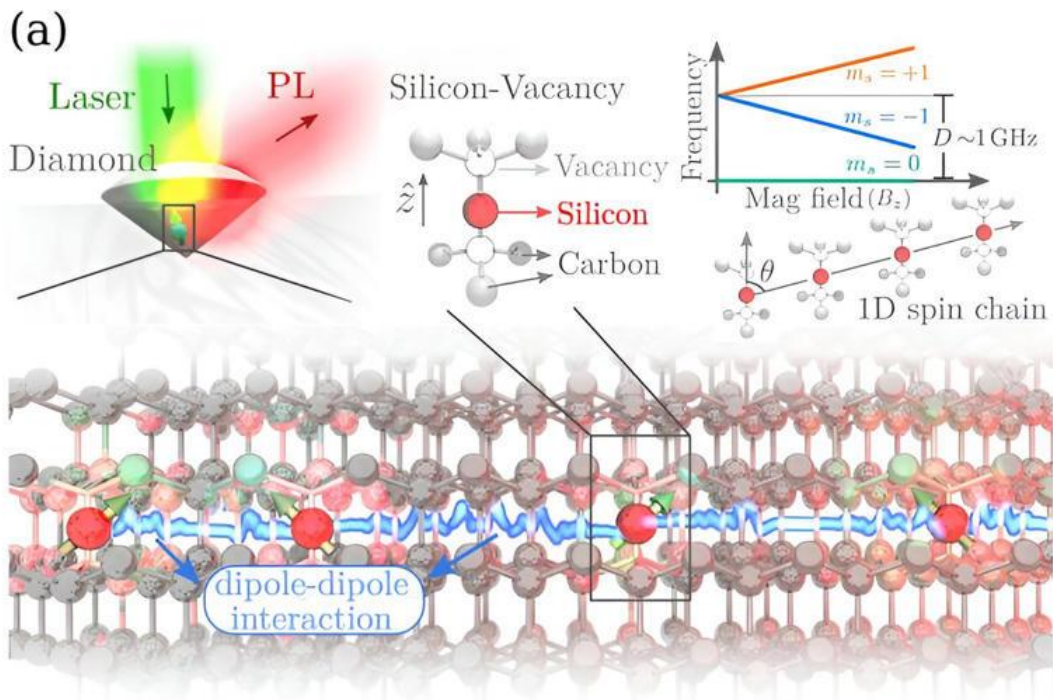

Schematic representation of Silicon-Vacancy in Diamond and the corresponding spin array of SiV's coupled through dipole-dipole interaction. Credit: Physical Review B (2024). DOI: 10.1103/PhysRevB.110.014413© Provided by Phys.org

Quantum computing, which uses the laws of quantum mechanics, can solve pressing problems in a broad range of fields, from medicine to machine learning, that are too complex for classical computers.

Quantum simulators are devices made of interacting quantum units that can be programmed to simulate complex models of the physical world. Scientists can then obtain information about these models, and, by extension, about the real world, by varying the interactions in a controlled way and measuring the resulting behavior of the quantum simulators.

In a [paper published in *Physical Review B*](#), a UC Riverside-led research team has proposed a chain of quantum magnetic objects, called spin centers, that, in the presence of an external magnetic field, can quantum simulate a variety of magnetic phases of matter as well as the transitions between these phases.

"We are designing new devices that house the spin centers and can be used to simulate and learn about interesting physical phenomena that cannot be fully studied with classical computers," said Shan-Wen Tsai, a professor of physics and astronomy, who led the research team. "Spin centers in solid state materials are

localized quantum objects with great untapped potential for the design of new quantum simulators."

According to Troy Losey, Tsai's graduate student and first author of the paper, advances with these devices could make it possible to study more efficient ways of storing and transferring information, while also developing methods needed to create room temperature quantum computers.

"We have many ideas for how to make improvements to spin-center-based quantum simulators compared to this initial proposed device," he said.

"Employing these new ideas and considering more complex arrangements of spin centers could help create quantum simulators that are easy to build and operate, while still being able to simulate novel and meaningful physics."

Tsai and Losey answer questions about the research:

What is a quantum simulator?

Tsai: It is a device that exploits the unusual behaviors of quantum mechanics to simulate interesting physics that is too difficult for a regular computer to calculate. Unlike quantum computers that operate with qubits and universal gate operations, quantum simulators are individually designed to simulate/solve specific problems.

By trading off universal programmability of quantum computers in favor of exploiting the richness of different quantum interactions and geometrical arrangements, quantum simulators may be easier to implement and provide new applications for quantum devices, which is relevant because quantum computers aren't yet universally useful.

A spin center is a roughly atom-sized quantum magnetic object that can be placed in a crystal. It can store quantum information, communicate with other spin centers, and be controlled with lasers.

What are some applications of this work?

Losey: We can build the proposed quantum simulator to simulate exotic magnetic phases of matter and the phase transitions between them. These phase transitions are of great interest because at these transitions the behaviors of very different systems become identical, which implies that there are underlying physical phenomena connecting these different systems.

The techniques used to build this device can also be used for spin-center-based quantum computers, which are a leading candidate for the development of room temperature quantum computers, whereas most quantum computers require extremely cold temperatures to function.

Furthermore, our device assumes that the spin centers are placed in a straight line, but it is possible to place the spin centers in up to 3-dimensional arrangements. This could allow for the study of spin-based information devices that are more efficient than methods that are currently used by computers.

As quantum simulators are easier to build and operate than quantum computers, we can currently use quantum simulators to solve certain problems that regular computers don't have the abilities to address, while we wait for quantum computers to become more refined.

However, this doesn't mean that quantum simulators can be built without challenge, as we are just now getting close to being good enough at manipulating spin centers, growing pure crystals, and working at low temperatures to build the quantum simulator that we propose.

More information: Troy Losey et al, Quantum simulation of the spin- 1/2 XYZ model using solid-state spin centers, *Physical Review B* (2024). DOI: [10.1103/PhysRevB.110.014413](https://doi.org/10.1103/PhysRevB.110.014413). OnarXiv: DOI: [10.48550/arxiv.2209.07516](https://doi.org/10.48550/arxiv.2209.07516)

At the very smallest scales, our intuitive view of reality no longer applies. It's almost as if physics is fundamentally indecisive, a truth that gets harder to ignore as we zoom in on the particles that pixelate our Universe.

In order to better understand it, physicists had to devise an [entirely new framework](#) to place it in, one based on probability over certainty. This is quantum theory, and it describes all sorts of phenomena, from [entanglement](#) to superposition.

Yet in spite of a century of experiments showing just how useful quantum theory is at explaining what we see, it's hard to shake our 'classical' view of the Universe's building blocks as reliable fixtures in time and space. Even [Einstein was forced](#) to ask his fellow physicist, "Do you really believe [the Moon](#) is not there when you are not looking at it?"

Numerous physicists have asked over the decades whether there is some way the physics we use to describe macroscopic experiences can also be used to explain all of quantum physics.

Now a new study has also determined that the answer is a big fat nope.

Specifically, neutrons fired in a beam in a [neutron interferometer](#) can exist in two places at the same time, something that is impossible under classical physics.

The test is based on a mathematical assertion called the [Leggett-Garg inequality](#), which states that a system is always determinately in one or the other of the states available to it. Basically, Schrödinger's Cat is either alive or dead, and we are able to determine which of those states it is in without our measurements having an effect on the outcome.

Related video: Gravitational Waves Create A 'Cosmic Symphony' That Scientists Are Tuning Into (Dailymotion)

Macro systems – those we can reliably understand using classical physics alone – obey the Leggett-Garg inequality. But systems in the quantum realm violate it. The cat is alive and dead simultaneously, an analogy for quantum superposition.

"The idea behind it is similar to the more famous [Bell's inequality](#), for which the Nobel Prize in Physics was awarded in 2022," [says physicist Elisabeth Kreuzgruber](#) of the Vienna University of Technology.

"However, Bell's inequality is about the question of how strongly the behavior of a particle is related to another quantum entangled particle. The Leggett-Garg inequality is only about one single object and asks the question: how is its state at specific points in time related to the state of the same object at other specific points in time?"

The neutron interferometer involves firing a beam of neutrons at a target. As the beam travels through the apparatus, it splits in two, with each of the beam's prongs traveling separate paths until they are later recombined.

Leggett and Garg's theorem states that a measurement on a simple binary system can effectively give two results. Measure it again in the future, those results will be correlated, but only up to a certain point.

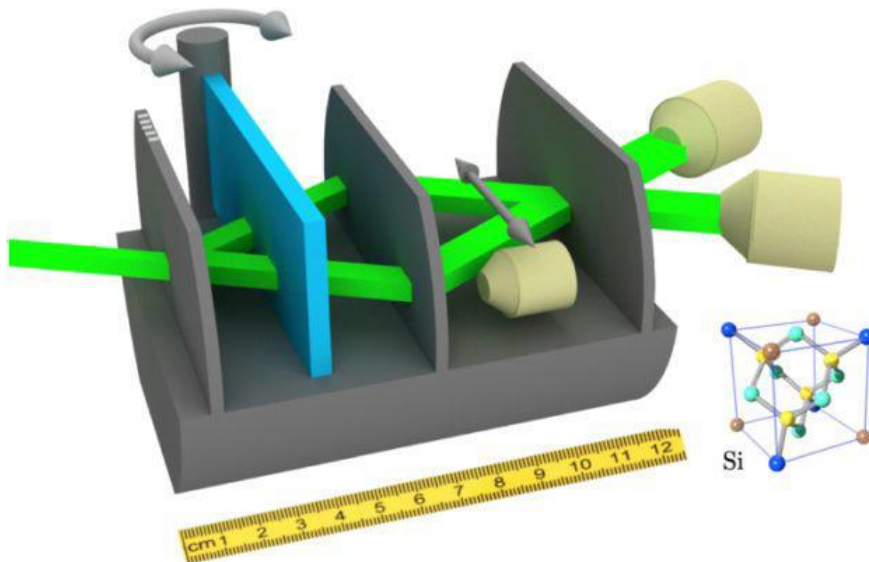

A diagram of the experiment showing the neutron beam split in two before being recombined. (Vienna University of Technology) © Provided by ScienceAlert

For quantum systems, Leggett and Garg's theorem no longer applies, permitting correlations above this threshold. In effect this would give researchers a way to distinguish whether a system needs a quantum theorem to be understood.

"However, it is not so easy to investigate this question experimentally," [says physicist Richard Wagner](#) of the Vienna University of Technology. "If we want to test macroscopic realism, then we need an object that is macroscopic in a certain sense, i.e. that has a size comparable to the size of our usual everyday objects."

In order to achieve this, the space between the two parts of the neutron beam in the interferometer is on a scale that's more macro than quantum.

"Quantum theory says that every single neutron travels on both paths at the same time," [says physicist Niels Geerits](#) of the Vienna University of Technology. "However, the two partial beams are several centimeters apart. In a sense, we are dealing with a quantum object that is huge by quantum standards."

Using several different measurement methods, the researchers probed the neutron beams at different times. And, sure enough, the measurements were too closely correlated for the classical rules of macro reality to be at play. The neutrons, their measurements suggested, were actually traveling simultaneously on two separate paths, separated by a distance of several centimeters.

It's just the latest in a [long string of Leggett-Garg experiments](#) that show we really do need quantum theory in order to describe the Universe we live in.

"Our experiment shows: Nature really is as strange as quantum theory claims," [says physicist Stephan Sponar](#) of the Vienna University of Technology. "No matter which classical, macroscopically realistic theory you come up with: It will never be able to explain reality. It doesn't work without quantum physics."

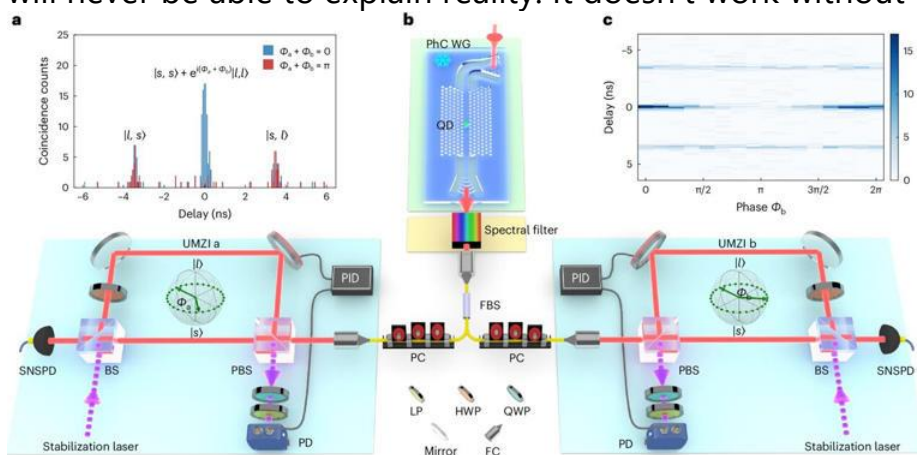

Schematic of photon scattering off a two-level emitter in a photonic crystal waveguide (PhC WG). A weak coherent state is coupled into the PhC WG via a shallow etched grating (SEG). In the photon scattering picture, a single-photon wave packet is predominantly reflected by elastic scattering on a two-level emitter, while the two-photon wave packet

can be inelastically scattered in the transmission direction, thereby generating the energy-time entangled photon pair. Credit: Nature Physics (2024). DOI: 10.1038/s41567-024-02543-8© Provided by Phys.org

A new [study](#) in *Nature Physics* demonstrates a novel method for generating quantum entanglement using a quantum dot, which violates the Bell inequality. This method uses ultra-low power levels and could pave the way for scalable and efficient quantum technologies.

Quantum entanglement is a requirement for quantum computing technologies. In this phenomenon, qubits (quantum bits)—the building blocks of quantum computers—become correlated irrespective of their physical distance.

This means that if the property of one qubit is measured, it impacts the other one. Quantum entanglement is verified through the Bell inequality, a theorem that tests the validity of quantum mechanics by measuring entangled qubits.

Phys.org spoke to the first author of the study, Dr. Shikai Liu, from The Niels Bohr Institute at the University of Copenhagen in Denmark. Dr. Liu's interest in quantum dots stemmed from his earlier work with traditional entanglement sources.

He told Phys.org, "During my Ph.D., I worked on generating entangled light sources using spontaneous parametric down-conversion (SPDC). However, the intrinsic weak nonlinearity of bulk crystals made it difficult to utilize pump photons fully. The giant nonlinearity at the single-photon level from quantum dots caught my attention and led me to this research."

The Bell inequality

As mentioned earlier, the heart of this research is the Bell inequality. Proposed by physicist John Stewart Bell in 1964, this mathematical expression helps distinguish between classical and quantum behavior.

In the quantum world, particles can exhibit correlations that are stronger than what is possible in the classical world. The Bell inequality provides a threshold: If

the correlations exceed this threshold, the nature of the correlations is quantum, implying quantum entanglement.

Dr. Liu elaborated, "The Bell inequality distinguishes between classical and quantum correlations. Any local realistic theory must satisfy the condition: All measured correlations between particles must be less than or equal to two."

The researchers used this to establish the validity of their experiment and whether the setup they constructed produced quantum entanglement. The setup itself was based on quantum dots and waveguides.

Artificial atoms on a chip

Quantum dots are nanoscale structures that behave like artificial atoms. Essentially, they are semiconductor chips designed to trap electrons within their structure.

By trapping electrons in a small space, the electrons exhibit quantized energy states as they do when they are confined in atoms. This is why quantum dots are said to behave like artificial atoms.

These quantum dots act as two-level systems, similar to natural atoms, but with the advantage of being integrated into a chip. Additionally, the energy levels can be tuned, determined by the size and composition of the quantum dot.

Quantum dot systems can act as emitter systems, which means they can emit single photons with high efficiency. Under certain conditions, the emitted photons can become entangled.

Coupling with a waveguide

To enhance the efficiency, coherence, and stability of the emitted photons from the quantum dot, the researchers coupled it with a photonic crystal waveguide.

These materials have a periodic structure of alternating high and low refractive index materials. This allows light to be guided through a tube-like structure, which is as thin as a human hair.

Waveguides, therefore, allow the control and manipulation of light propagation in terms of direction and wavelength, thereby enhancing light-matter interactions.

However, achieving efficient coupling between the waveguide and quantum dot poses significant challenges.

"To improve the light-matter interaction, we fabricated a photonic-crystal waveguide that provides strong confinement for the quantum dot," explained Dr. Liu. "This led to not only a high coupling efficiency of emitted light into the waveguide (greater than 90%) but also a Purcell enhancement of 16 by slowing down light in the nanostructure and increasing its interaction time with the quantum dot."

Purcell enhancement refers to the phenomenon where the rate of spontaneous emission of a quantum emitter (such as a quantum dot) is increased when placed in a resonant optical cavity or near a structured photonic environment.

In simpler terms, Purcell enhancement boosts the emission of light from quantum emitters by placing them in environments that amplify their interaction with light. This works by changing how many different ways light can be emitted in the area around the emitter.

Violation of Bell inequality

The team also had to contend with rapid dephasing (quick loss of coherence) induced by thermal vibrations in the crystal lattice. These vibrations disrupt the stable quantum states of particles, making it harder to maintain and measure their quantum properties accurately.

Their solution was to cool the chip to a frigid -269°C to minimize unwanted interactions between the quantum dot and phonons in the semiconductor material.

Once their two-level emitter system was in place for producing the entangled photons, the researchers used two unbalanced Mach-Zehnder interferometers to perform the CHSH (Clauser-Horne-Shimony-Holt) Bell inequality test. The CHSH is a form of the Bell inequality.

By carefully setting up the interferometer phases, the researchers measured Franson interference between the emitted photons. Franson interference is a type of interference pattern observed in quantum optics experiments involving entangled photons.

"The observed S parameter of 2.67 ± 0.16 in our measurements is significantly above the locality bound of 2. This result confirmed the violation of the Bell inequality, thereby validating the energy-time entangled state generated via our method," said Dr. Liu.

This violation is crucial as it confirms the quantum nature of the correlations between the photons.

Energy efficiency and future work

One of the standout features of their two-level emitter setup is its energy efficiency.

The entanglement was generated at pump powers as low as 7.2 picowatts, approximately 1,000 times less than traditional single-photon sources. This ultra-low power operation, combined with the on-chip integration, makes the method highly promising for practical quantum technologies.

Dr. Liu envisions several exciting directions for future research. "One avenue is exploring complex photonic quantum states and many-body interactions through inelastic scattering off multiple two-level emitters," he suggested. "Additionally, further integration of our method into compatible photonic circuits will facilitate more functionalities with a small footprint, enhancing versatile photonic quantum applications involving computing, communication, and sensing."

More information: Shikai Liu et al, Violation of Bell inequality by photon scattering on a two-level emitter, *Nature Physics* (2024). [DOI: 10.1038/s41567-024-02543-8](https://doi.org/10.1038/s41567-024-02543-8)

Scientists in Finland say they have made inroads toward "fault-tolerant" quantum computing after achieving record-low error rates in a prototype quantum processor — potentially paving the way to more practical and stable [quantum computers](#).

In a [statement](#), researchers at IQM Quantum Computers said their technology had broken ground in two key areas: the accuracy of operations between qubits — the most basic units of quantum information — and the stability of qubits over time.

These factors determine the precision and durability of quantum operations in a device. High accuracy, or fidelity, between qubits allows for more precise calculations and fewer errors. Meanwhile, the stability, or "coherence," between qubits ensures that quantum information is maintained long enough to perform calculations.

IQM representatives said scientists had achieved 99.9% fidelity in two-qubit gate operations and hit a new record in "qubit relaxation time," meaning the time it takes for a qubit to lose its quantum state.

Related: [Next-gen quantum computers could be powered using chip with high-energy lasers made 10,000 times smaller](#)

These achievements bring fault-tolerant quantum computing — where errors in quantum calculations correct themselves automatically — closer to reality, IQM representatives said. This was particularly apparent in testing the quantum gates.

Quantum gates are the building blocks of quantum circuits, similar to logic gates in classical computers. Logic gates are digital switches that act as decision-makers in computers, using binary data (1s and 0s) to perform basic operations.

High fidelity in two-qubit gates are key for generating entangled states — when qubits become interconnected in such a way that the state of one directly affects the state of the other, regardless of the distance between them. Quantum entanglement is a cornerstone of [quantum mechanics](#) and what Einstein dubbed "spooky action at a distance."

For the test, the coherence times were measured by the relaxation time (T1) and the dephasing time (T2). These refer to how long a qubit can retain its quantum state before it returns to its normal state and how long a qubit can stay in sync with other qubits, respectively.

IQM recorded a T1 of 0.964 millisecond, with a possible variation of 0.092 millisecond, and a T2 of 1.155 millisecond with a 0.188-millisecond variable. This means the qubits maintained their information and quantum state for nearly 1 millisecond.

While this doesn't sound like a lot, it is considerable in the world of quantum operations, where typical coherence times are [often on the order of microseconds](#). IBM's [127-qubit Eagle processor](#), for instance, can manage coherence times of just over 400 microseconds.

"The significance of these results stems from the fact that only very few organizations have achieved comparable performance numbers before," IQM representatives said in the statement.

If this technology is integrated into a future quantum processor, it can be used in more complex use cases than IQM's [20-qubit quantum computer](#) — its most powerful machine today. The researchers plan to explore potential applications in fields such as machine learning, cybersecurity, route optimization, quantum sensor simulation and health care.

Quantum computing moves from NISQ to FTQC

Aug. 28, 2024

While a hard demarcation between these two eras was expected by some, it's trending toward more of an overlap and gradual transition between when one era ends and the other begins.

[Doug Finke](#)

At Global Quantum Intelligence (GQI), we see a lot of roadmaps from quantum providers and fully expect continuing advances in the capabilities of both quantum hardware and quantum software during the next several years. In fact, we believe we'll start seeing organizations using quantum technology for production purposes within the next few years. Some call it Quantum Advantage while others call it Quantum Utility, but in this article, I'll call it Quantum Production to distinguish it from one-off proof-of-concept experiments vs. those running the use cases on a repeated, regular basis.

Although we initially did not expect to see fault-tolerant quantum computers (FTQC) until the 2030s, recent advances lead us to believe that we'll start seeing what we call early FTQC processors available during the second half of this decade. One way we measure the capability of a quantum computer is a measure we call Quops, which stands for successful quantum operations. And we classify quantum evolution according to the following eras: Intermediate, Early, Large Scale, and Mature based upon how many Quops machines of that generation can process. Quops is a function of both the number of qubits available in a quantum processor and the logical error rate (LER) for these qubits.

For noisy intermediate-scale quantum (NISQ) processors, which don't have any error correction, the logical error rate will be the same as the physical error rate (PER). But in FTQC machines, which implement error correction codes that group together physical qubits to create a logical qubit, the LER will be much better than the PER. This is the purpose of error correction technology.

FTQC: Fault-tolerant quantum computers

We expect to see Early FTQC machines available within the next five years that can achieve capabilities within the MegaQuops or GigaQuops regimes. These initial machines may contain a few thousand physical qubits that will translate to roughly a few 100 or so logical qubits. This should be enough to run a few useful applications, but still won't be powerful enough to run intensive quantum applications like Shor's algorithm that will require machines with TeraQuops capabilities. We don't expect those Large Scale FTQC machines to be available until the 2030s and they will provide thousands of logical qubits for calculations with potentially millions of physical qubits.

The chart below demonstrates how error correction can improve the LER using one specific error correction code called the surface code as a function of the initial PER. As you might anticipate, the better the PER that the code starts with, the better the resulting LER will be. But another factor affects the physical qubits grouped together to create the logical qubit: we call it the physical-to-logical ratio. Codes that have a larger physical-to-logical ratio will provide better error resistance. In the chart below, the third column describes the code being implemented with the notation $[[n,k,d]]$. The "n" indicates the number of physical qubits used within a group, the "k" represents the number of logical qubits that it creates, and the "d" stands for the distance between codewords within the encoding. The larger the distance, the more able that code is to detect and correct errors. Beyond the surface code used within this chart example, many other codes are being researched that

may be more efficient, depending upon the code and the specific quantum processor it's being implemented on.

(Credit: Global Quantum Intelligence)

Physical	Physical Error Rate	Surface Code	Distance	Encoding Rate	Logical Error Rate	GQI Era	GQI Technical Regime		
	PER	[[n,k,d]]	D	(inc. ancillas)	LER		Quop	Tar Logi	
99.5%	5.0E-03	[[144,1,12]]	12	0.0035	1.1E-03	Intermediate	KILOQUOP thousands of quantum Operations	10	
99.9%	1.0E-03	none	1	1	1.0E-03			10	
99.99%	1.0E-04	none	1	1	1.0E-04			10	
99.999%	1.0E-05	none	1	1	1.0E-05			10	
99.5%	5.0E-03	[[1024,1,32]]	32	0.0005	1.1E-06	Early	MEGAQUOP	10	
99.9%	1.0E-03	[[81,1,9]]	9	0.006	1.0E-06			10	
99.99%	1.0E-04	[[16,1,4]]	4	0.03	1.0E-06		millions of quantum Operations	10	
99.999%	1.0E-05	[[9,1,3]]	3	0.06	1.0E-07		10		
99.5%	5.0E-03	[[2704,1,52]]	52	0.0002	1.1E-09		GIGAQUOP	25	
99.9%	1.0E-03	[[225,1,15]]	15	0.002	1.0E-09			25	
99.99%	1.0E-04	[[49,1,7]]	7	0.01	1.0E-09			billions of quantum Operations	25
99.999%	1.0E-05	[[25,1,5]]	5	0.02	1.0E-10			25	
99.5%	5.0E-03	[[5184,1,72]]	72	0.0001	1.0E-12	Large Scale	TERAQUOP	2,5	
99.9%	1.0E-03	[[441,1,21]]	21	0.001	1.0E-12			2,5	
99.99%	1.0E-04	[[100,1,10]]	10	0.005	1.0E-12		trillions of quantum Operations	2,5	
99.999%	1.0E-05	[[49,1,7]]	7	0.010	1.0E-13		2,5		
99.5%	5.0E-03	[[8464,1,92]]	92	0.0001	1.0E-15	Mature	PETAQUOP	20,0	
99.9%	1.0E-03	[[676,1,26]]	26	0.001	3.2E-15			20,0	
99.99%	1.0E-04	[[169,1,13]]	13	0.003	1.0E-15		quadrillions of quantum operations	20,0	
99.999%	1.0E-05	[[81,1,9]]	9	0.006	1.0E-16		20,0		

NISQ: Noisy intermediate-scale quantum

On the other hand, we also see advances occurring in more capable NISQ processors and associated algorithms that may also be able to run useful applications within the 2025 to 2029 timeframe. We've already seen a few companies demonstrate two-qubit fidelities of greater than 99.9% for their physical gates. And we've also seen advances in algorithms to get the most out of these physical gates. This software includes hybrid classical/quantum architectures, variational quantum algorithms, error mitigation and suppression techniques, circuit knitting, zero noise extrapolation, probabilistic error cancellation, and other classical post processing to improve quantum results. Moreover, the roadmaps we've seen indicate we may have available NISQ processors with 10,000 of physical qubits during the second half of this decade.

End users may have an interesting choice soon—within the next five years. Do they want to use an Early FTQC machine that provides about 100 logical qubits with two-qubit gate fidelities of greater than 99.9999%, or do they want to use a NISQ machine that contains around 10,000 physical qubits with two-qubit gate fidelities of 99.9% or perhaps 99.99%?

Many quantum researchers are skeptical anyone will ever run useful applications on a NISQ quantum computer. Beyond the fact that these machines still have noise issues, one of the other reasons is that many of these applications would rely on heuristic algorithms such as QAOA or VQE, which no one can theoretically prove will work. People will need to try them out to see if they work or not. On the other hand, theoretical proof exists that certain algorithms, such as Shor’s algorithm, can run on a FTQC and provide an accurate answer. But we would remind our readers that many of the classical artificial intelligence (AI) algorithms that have become popular in recent days are also heuristic and computer scientists do not yet have a theoretical proof that they should work. Yet, of course, these AI algorithms do work.

A particularly interesting paper we recently saw posted on *arXiv* is titled “[A typology of quantum algorithms](#),” authored by researchers at the Université Paris-Saclay and Quantinuum. In the paper, they classified 133 different quantum algorithms by a number of different factors, including whether the algorithm could be implemented on a NISQ processor or required a large-scale quantum (LSQ) processor. Of the 133 algorithms shown in the summary Classification Table at the end of the paper, a total of 50 were classified as potential candidates for using a NISQ processor, while the remaining candidates require a LSQ machine. It’s possible one of these NISQ algorithms can indeed provide a usable commercial quantum production before the FTQC quantum computers are available.

We aren’t at the point yet where we can definitely say which quantum applications will be able to provide commercially useful results on which machines. But the one thing that makes us optimistic is the diversity of innovative approaches and rapid advances organizations are making in both hardware and software to get us to the point where the systems can be used for quantum production for useful applications. Although some of these innovative approaches will fail, we fully believe that others will work and start delivering within the next few years on the promise of a quantum computer. The applications in production may only be a handful for the next few years, but this initial small number will grow substantially in the 2030s as more TeraQuop large-scale FTQC systems become available, which will enable many more algorithms to be run successfully.

While some may expect to see a hard demarcation between the end of the NISQ era and beginning of the FTQC era, in reality these eras will overlap, and we’ll see a gradual transition.

In a continuous pursuit to understand the fundamental laws that govern the universe, researchers have ventured deep into the realms of string theory, loop quantum gravity, and quantum geometry. These advanced theoretical frameworks have revealed an especially compelling concept: the generalized uncertainty principle (GUP). This principle fundamentally challenges traditional physics by proposing a minimal measurable length, which could profoundly alter our foundational understanding of space and time. It challenges the bedrock of classical mechanics and invites a reevaluation of quantum mechanics and general relativity.

The GUP has catalyzed an impressive range of research efforts, extending from the microscopic domain of atomic physics to the cosmic scales of astrophysics and cosmology. Investigations have explored phenomena such as gravitational bar detectors, condensed matter systems, and the dynamics of quantum optics.

Each study contributes to a broader understanding of the potential implications of the GUP, suggesting it could fundamentally transform our understanding of physics across various scales and systems.

Rethinking the Planck constant

Building upon these insights, our research, [published](#) in the *International Journal of Modern Physics D*, introduces a transformative concept: an "effective" Planck constant. This idea challenges the traditional view of the Planck constant as a static, immutable value, proposing instead that it might vary depending on specific experimental or environmental conditions, particularly the momentum or position of the system under observation.

This hypothesis emerges from the GUP, suggesting that the Planck constant is not merely a universal constant but dynamically interacts with the momentum and position of the physical systems being measured.

This new perspective encourages a rethinking of fundamental constants in physics, implying they could be dynamic properties interacting significantly with the physical attributes of systems, such as their mass, size, and quantum state.

A bridge between quantum mechanics and the cosmos

Central to our investigation is a simple yet profound formula: $m r c = \hbar'$

This formula demonstrates that by inputting the Planck mass and Planck length as the mass and radius, respectively, we derive what we term the "traditional" Planck constant, \hbar . This outcome highlights a significant and intrinsic connection between fundamental physical constants and the fabric of the universe.

When this formula is specifically applied to the electron, the results are particularly illuminating: \hbar' equates to the fine structure constant multiplied by \hbar , aligning perfectly with established values from quantum mechanics. This precise alignment reinforces the robustness of our formula and its relevance to fundamental particle physics.

For particles like pions, kaons, and gauge bosons, the calculated \hbar' remains comparable in magnitude to \hbar , demonstrating the universal applicability of our formula across different scales and particle types.

However, when applied to larger systems, such as chemical elements like helium and oxygen, \hbar' significantly exceeds \hbar by a few orders of magnitude (10 to 10^3), suggesting a scale-dependent variability of the effective Planck constant.

Most importantly, when the formula is applied to the entire universe, it yields a value for \hbar' that offers a potential solution to the cosmological constant problem. This intriguing result suggests a novel approach to resolving one of the most challenging and persistent issues in theoretical physics. By bridging observed discrepancies in vacuum energy densities with empirical observations, the formula provides a reconciled understanding of cosmic phenomena.

Linking to the Bekenstein entropy bound

Furthermore, our research establishes a critical link between the variable Planck constant \hbar' and the Bekenstein entropy bound—a fundamental principle that limits the amount of information that can be contained within a given physical system.

This connection not only supports the theoretical validity of the Bekenstein bound but also significantly enhances our understanding of the role of entropy and information at the quantum level across different scales and systems. This insight suggests a deeper, more nuanced understanding of the relationships between information, entropy, and fundamental constants in the universe.

Conclusion

The implications of our findings are both profound and potentially transformative. By establishing a bridge between quantum mechanics, thermodynamics, and cosmology, our research opens new avenues for a deeper understanding of the universe at its most fundamental level.

This work not only enriches our theoretical insights but also invites the scientific community to reconsider enduring mysteries in physics, such as the nature of dark matter and the cosmological constant problem.

We hope that this research will inspire further exploration and vibrant discussion within the scientific community. By examining the universe through this innovative theoretical lens, we advocate for a more holistic and comprehensive understanding of the fundamental principles that govern everything from the minutest particles to the vast expanses of space.

This journey into the depths of physical laws is far from complete, and we eagerly anticipate the new perspectives and discoveries that it will bring.

This story is part of [Science X Dialog](#), where researchers can report findings from their published research articles. [Visit this page](#) for information about Science X Dialog and how to participate.

More information: Ahmed Farag Ali et al, Theoretical and observational implications of Planck's constant as a running fine structure

constant, *International Journal of Modern Physics D* (2024). DOI: [10.1142/S0218271824500366](https://doi.org/10.1142/S0218271824500366). On arXiv: DOI: [10.48550/arxiv.2210.06262](https://doi.org/10.48550/arxiv.2210.06262)

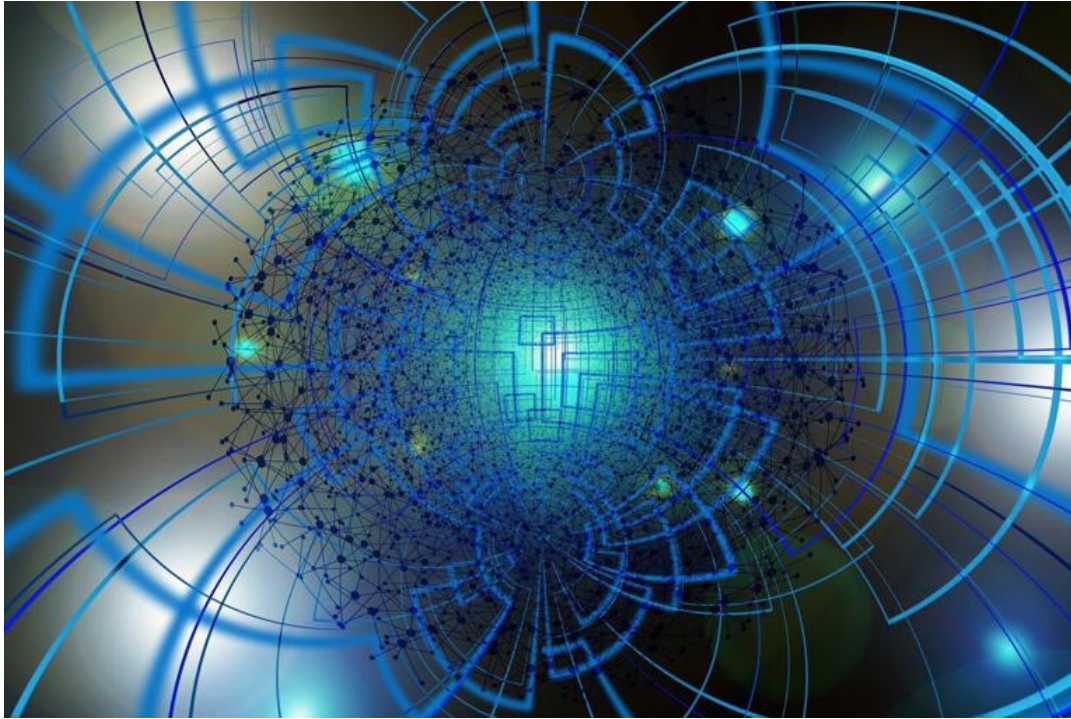

Credit: Pixabay/CC0 Public Domain

For more than 20 years, quantum researchers have wondered whether a quantum system can have maximum entanglement in the presence of noise. A mathematician from Spain recently answered the question: No.

The idea of quantum entanglement began with a debate between Niels Bohr and Albert Einstein; Einstein didn't like the notion and derisively called it "spooky action at a distance." Quantum physicists puzzled over the concept for decades, and it was refined into a fundamental principle known as the [Bell inequalities](#), which delineated the classical and quantum realms.

Entanglement occurs when the objects in a system, whatever they are, cannot be described independently of one another. They are somehow connected in ways

scientists have not been able to explain—or rather, understand, since it seems so unintuitive to us classical beings who do classical, not quantum, thinking.

Quantum scientists are using the entanglement phenomenon to build and improve technologies such as quantum computers, quantum encryption, quantum sensors and quantum teleportation, and want to go further.

Many quantum scientists believe that quantum computers will require particles or molecules in an entangled state. Such states exist only in quantum mechanics. Consider a system of two entangled electrons whose net spin is zero. Measure the spin of one and, whatever it is, the entangled partner seemingly immediately falls into the opposite spin, no matter the distance.

However, rather mysteriously, no information has traveled between the two particles. Entanglement has been demonstrated for a system whose members are [more than 1,000 km apart](#).

A qubit is a quantum bit, where the state (here, an electron) can exist in multiple states at the same time; the electron is said to be in a quantum superposition. Above, before it is measured, each electron is a qubit, a superposition of a spin up state and a spin down state. The maximally entangled quantum state of two qubits is called a Bell state; the qubits exhibit a perfect correlation that cannot be explained without quantum mechanics.

In recent decades, scientists and engineers have come to view entanglement as a resource enabling tasks in quantum technologies that are impossible in classical systems. When using quantum entanglement, researchers would like to attain a maximally entangled state, where the particles, light or molecules have maximum entangled connections to one another in the real world—the particles are correlated in a way that is not possible in the classical world, and all possible measurements of the entangled system can be performed. This would provide the most useful form of entanglement and would be a gold standard in applications.

In the absence of any noise—any disturbance of the entangled state, such as thermal fluctuations, mechanical vibrations, fluctuations in the voltage of a power

supply, etc.—quantum information theorists know the maximally entangled state exists, which is independent of measurements.

But the real world has unavoidable noise knocking on the doors everywhere, including on entangled states. Can the maximally entangled state still exist? Indeed, this question is ranked number 5 on the [list of open quantum problems](#) published by the Institute for Quantum Optics and Quantum Information in Vienna.

Now Julio I. de Vicente of the Universidad Carlos III de Madrid has answered the question in the negative—if noise is present, it is not possible to simultaneously maximize all types of entanglement of the system. His work is [published](#) in *Physical Review Letters*.

"The best state that one can prepare depends on the choice of entanglement quantifier as soon as we move away from the idealized scenario even under the slightest form of noise," de Vicente told Phys.org. "Thus, in the noisy regime, there is no universal notion of maximal entanglement, and the best state one can prepare is task dependent."

An "entanglement quantifier" assigns a number to the degree of entanglement. A "task" in this context is the purpose for which an entangled state is utilized.

It is important to understand that Vicente's result only applies to noisy maximally entangled states with a fixed spectrum. Two quantum states have the same spectrum if they have the same amount of underlying noise. de Vicente's results do not apply to the case where we are allowed to change the spectrum (that is, increase or decrease the noise) between two quantum states.

One important entanglement quantifier is entanglement entropy; as in thermodynamics, it is a measure of the amount of disorder in a system. The Bell states have a high amount of entropy, and two-qubit noisy states were known to maximize other quantifiers of entanglement. It was strongly believed that they should maximize all possible quantifiers, which now turns out to be incorrect.

Namit Anand, a staff scientist at KBR and the NASA Ames' Quantum AI Lab (QuAIL), says, "This comes as a surprise, since it was known that there exist classes of noisy two-qubit states that seem to be like the generalization of the Bell state."

But de Vicente's proof implies, among other things, that the equivalent of the Bell state doesn't exist in the presence of noise.

"This reminds us that the story is not as simple as it seems," Anand said. "And perhaps, as often happens in fundamental research, when an open problem is solved, it leaves us with more questions than answers."

More information: Julio I. de Vicente, Maximally Entangled Mixed States for a Fixed Spectrum Do Not Always Exist, *Physical Review Letters* (2024). [DOI: 10.1103/PhysRevLett.133.050202](https://doi.org/10.1103/PhysRevLett.133.050202). On *arXiv*: arxiv.org/abs/2402.05673

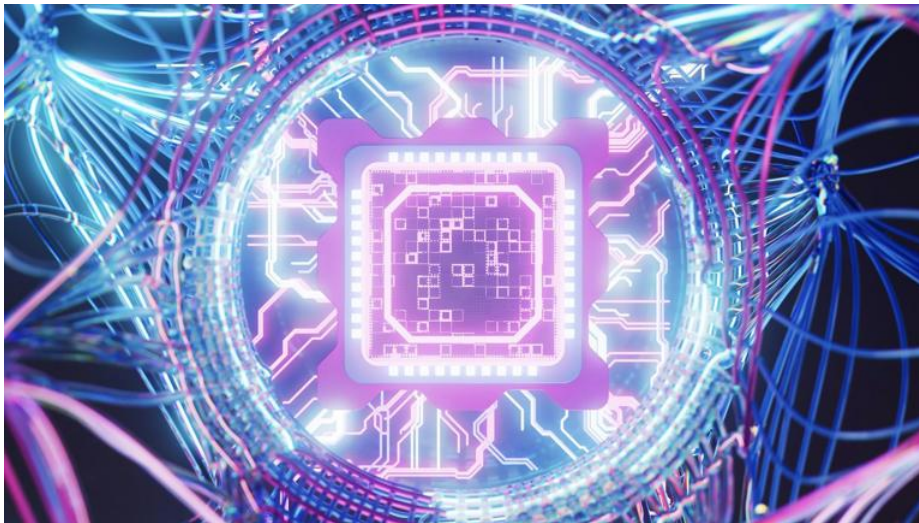

By giving each qubit extra frequencies, scientists can get them to work together to process calculations as if they were a part of a single quantum computer. © Getty Images/Eugene Mymrin

Physicists have created a new model for quantum computers that could more easily scale them up and make them more powerful than previously imagined.

The new theory, outlined in a study published May 21 in the journal [PRX Quantum](#), proposes linking qubits, the fundamental workhorses of quantum computers, over vast distances to work as if they were part of a single super-powerful machine.

Where bits are used in classical computing to process data in binary states of 1 or 0, and in sequence, [quantum computing](#) uses qubits (which rely on the laws of [quantum mechanics](#)) to encode data in a superposition of 1 and 0. This means data can be encoded in both states simultaneously. Each qubit operates in a given frequency.

These qubits can then be stitched together through [quantum entanglement](#) — where their data is linked across vast separations over time or space — to process calculations in parallel. The more qubits are entangled, the more exponentially powerful a quantum computer will become.

Entangled qubits must share the same frequency. But the study proposes giving them "extra" operating frequencies so they can resonate with other qubits or work on their own if needed.

The road to quantum supremacy

With enough entangled qubits, future quantum computers could perform calculations that would have taken a classical computer thousands of years in just a few seconds. But you need a quantum processor with millions of qubits to achieve this state of "quantum supremacy," whereas the [most powerful today have just 1,000 qubits](#).

But maintaining the stability between entangled qubits, so that you can process data, is difficult and requires complex electronics and equipment. Scaling up the qubits in a quantum computer so it's powerful enough to leapfrog [today's most powerful supercomputers](#) also represents a major hurdle — as you would also need to scale up that complex circuitry.

Related: [Quantum compasses closer to replacing GPS after scientists squeeze key refrigerator-sized laser system onto a microchip](#)

But the scientists propose that by giving each qubit extra frequencies, they can get them to work together to process calculations as if they were a part of a single quantum computer. This is despite being potentially separated over vast distances. It means that instead of one massive quantum processor that is difficult to maintain, you can use several smaller ones linked together.

“Each qubit in a quantum computer operates at a specific frequency. Realizing the capabilities unique to a quantum computer relies on being able to control each qubit individually via a distinct frequency, as well as to link pairs of qubits by matching their frequencies,” study lead author [Vanita Srinivasa](#), assistant professor of quantum information at the University of Rhode Island, said in a [statement](#).

Fitting qubits together like 'LEGO blocks'

The scientists said that by applying oscillating voltages, they could generate extra frequencies for each qubit. By doing this, you can link multiple qubits together by tapping into newly generated shared frequencies, without having to match their original frequencies. The qubits can then be linked together, yet also be controlled individually using their original frequencies.

“This approach to scaling is like building a larger system using fixed-size LEGO blocks, which are like individual modules, and connecting them using longer pieces that are strong enough to maintain the connection between the blocks for a sufficient time before external influences break the links,” Srinivasa said in the statement.

The model aims to overcome challenges that scientists will face in scaling up quantum processors in the future. These are normally fabricated with semiconductors and use billions of tiny transistors that can be harnessed to make compact qubits. However, simply adding more and more qubits to a quantum processor will one day be infeasible, the scientists said.

Using the new model, the researchers believe future quantum computers will be built in a modular way — with smaller arrays of qubits in quantum processors that are connected using robust and long-range entangled links. This will render them more powerful and capable of much faster calculations than is feasible using the technology that we have today.

Scientists from Yale University and the U.S. Department of Energy's (DOE)

Brookhaven National Laboratory have developed a systematic approach to understanding how energy is lost from the materials that make up qubits. Energy loss inhibits the performance of these quantum computer building blocks, so determining its sources—and adjusting the materials as necessary—can help bring researchers closer to designing quantum computers that could revolutionize several scientific fields.

With their new approach, the Yale scientists were able to design a compact device that could store quantum information for more than one millisecond.

This research, [published](#) in *Nature Communications*, was conducted as part of the Co-Design Center for Quantum Advantage (C²QA), a national quantum information science research center led by Brookhaven Lab. Yale is a key partner of the center.

"A significant hurdle that we must overcome is improving the ability of qubits to retain the quantum information encoded in them. This is known as coherence," explained Suhas Ganjam, who is first author of the new paper. Ganjam conducted the research as a doctoral student at Yale and is now a research scientist at Google.

A few years ago, Princeton University researchers—who joined C²QA upon its establishment —[designed qubits](#) with a record-breaking coherence time of 0.3 milliseconds by replacing the traditionally used niobium or aluminum with a superconducting metal called tantalum. This indicated that qubits' constituent materials directly affect their performance, but the reasons for this were still unclear.

So, scientists contributing to C²QA began investigating the [different kinds of tantalum oxides](#) that form on tantalum's surface when it is exposed to air. They further improved coherence by [coating tantalum](#) with a thin layer of magnesium that prevented the material's oxidation.

"Researchers have been building devices with better coherence times. But there are so many different sources of energy loss, and we still couldn't distinguish

which ones were improving," said Ganjam. "So, we set out to differentiate between the different types of loss."

Under the supervision of Robert Schoelkopf, a physicist at Yale University who leads the Devices Thrust of C²QA, Ganjam designed a device called a tripole stripline.

This new device consists of three superconducting thin-film strips patterned on a substrate, similar to other quantum devices. The strips were arranged in a special way so that the researchers could not only quantify energy lost but also determine where it was being lost by testing the device in three different modes—one for each pair of superconducting electrodes.

For example, the researchers could differentiate between surface loss and bulk dielectric loss by observing modes in which electromagnetic fields were either confined to the surface of the device or spread throughout the substrate. If they observed more loss from the mode in which electromagnetic fields were confined to the surface of the device, the loss was dominated by the surface contribution.

"Through our electromagnetic tests with the tripole stripline, we could observe that devices made with tantalum and aluminum lose different amounts of energy in different ways," Ganjam explained.

In particular, the researchers found that using a tantalum thin film, rather than an aluminum thin film, reduced surface loss. And using a fabrication technique called annealing, which involves heating a sapphire substrate and letting it cool slowly, reduced the bulk dielectric loss.

"We wanted to know why the different materials and fabrication techniques influenced loss like this," Ganjam said. "So, we turned to our collaborators from the Center for Functional Nanomaterials."

Quantum materials through the microscopy lens

The Center for Functional Nanomaterials (CFN) is a DOE Office of Science user facility at Brookhaven Lab with a state-of-the-art Electron Microscopy facility. Using transmission electron microscopy and scanning transmission electron

microscopy to look at the materials' microscopic structure, scientists from this facility can help other researchers, like Ganjam and Schoelkopf, better understand the materials they are working with.

"We suspect that qubit coherence is limited by energy loss that is due to contaminants or defects in the materials," explained Minghzaio Liu, a senior scientist at CFN. "So, we analyze the quantum materials at CFN to look for these coherence-limiting characteristics."

Kim Kisslinger, an advanced technical associate at CFN, extracted microscopic cross-sections of the Yale scientists' materials and devices and analyzed them at the atomic level.

"I view projects like this through an electron microscopy lens," said Kisslinger. "From crystallinity to chemical composition to epitaxy, which is related to the orientation of the crystal materials, I can tell our collaborators exactly what is going on with their materials and help them correlate these properties with the materials' performance."

Liu said, "Kim helps our collaborators better understand their materials, but he also helps them make meaningful improvements through an iterative process."

Kisslinger added, "CFN is home to cutting-edge equipment that can support the materials research needed for quantum devices. But we also have some of the most qualified scientists and specialists in the world. This combination of quality people and quality equipment is unique to CFN."

Collaborative efforts yield improved devices

With a well-rounded understanding of the electromagnetic properties of their devices, as well as the material composition, the Yale researchers utilized an energy loss model that could predict a device's coherence based on its constituent materials and the circuit geometry. And with the help of this predictive model, they optimized circuit geometry to build a quantum device with a coherence time greater than one millisecond.

"This research marks an important milestone in the C²QA mission. Even beyond the longer coherence time, it demonstrates a path forward to further coherence enhancements through the close collaboration of quantum device and materials scientists," said C²QA Deputy Director Kai-Mei Fu.

The collaboration between the qubit design experts from the Schoelkopf lab and CFN materials characterization experts, which began with the establishment of the center, embodies C²QA's principle of "co-designing" materials and algorithms to achieve quantum computers that outperform classical computers.

"Collaborations like this one are key to unlocking the best materials and optimal fabrication processes that will help C²QA realize their goal," Ganjam said.

"It has been quite rewarding to see these qubit design projects grow in scope and success over the years," added Liu. "Scientific advances like this are not possible without collaboration."

More information: Suhas Ganjam et al, Surpassing millisecond coherence in on chip superconducting quantum memories by optimizing materials and circuit design, *Nature Communications* (2024). [DOI: 10.1038/s41467-024-47857-6](https://doi.org/10.1038/s41467-024-47857-6)

Strange Motion of Neutrons Proves Nature Is Fundamentally Bizarre© Provided by ScienceAlert

At the very smallest scales, our intuitive view of reality no longer applies. It's almost as if physics is fundamentally indecisive, a truth that gets harder to ignore as we zoom in on the particles that pixelate our Universe.

In order to better understand it, physicists had to devise an [entirely new framework](#) to place it in, one based on probability over certainty. This is quantum theory, and it describes all sorts of phenomena, from [entanglement](#) to superposition.

Yet in spite of a century of experiments showing just how useful quantum theory is at explaining what we see, it's hard to shake our 'classical' view of the Universe's building blocks as reliable fixtures in time and space. Even [Einstein was](#)

[forced](#) to ask his fellow physicist, "Do you really believe [the Moon](#) is not there when you are not looking at it?"

Numerous physicists have asked over the decades whether there is some way the physics we use to describe macroscopic experiences can also be used to explain all of quantum physics.

Now a new study has also determined that the answer is a big fat nope.

Specifically, neutrons fired in a beam in a [neutron interferometer](#) can exist in two places at the same time, something that is impossible under classical physics.

The test is based on a mathematical assertion called the [Leggett-Garg inequality](#), which states that a system is always determinately in one or the other of the states available to it. Basically, Schrödinger's Cat is either alive or dead, and we are able to determine which of those states it is in without our measurements having an effect on the outcome.

Macro systems – those we can reliably understand using classical physics alone – obey the Leggett-Garg inequality. But systems in the quantum realm violate it. The cat is alive and dead simultaneously, an analogy for quantum superposition.

"The idea behind it is similar to the more famous [Bell's inequality](#), for which the Nobel Prize in Physics was awarded in 2022," [says physicist Elisabeth Kreuzgruber](#) of the Vienna University of Technology.

"However, Bell's inequality is about the question of how strongly the behavior of a particle is related to another quantum entangled particle. The Leggett-Garg inequality is only about one single object and asks the question: how is its state at specific points in time-related to the state of the same object at other specific points in time?"

The neutron interferometer involves firing a beam of neutrons at a target. As the beam travels through the apparatus, it splits in two, with each of the beam's prongs traveling separate paths until they are later recombined.

Leggett and Garg's theorem states that a measurement on a simple binary system can effectively give two results. Measure it again in the future, those results will be correlated, but only up to a certain point.

For quantum systems, Leggett and Garg's theorem no longer applies, permitting correlations above this threshold. In effect this would give researchers a way to distinguish whether a system needs a quantum theorem to be understood.

"However, it is not so easy to investigate this question experimentally," [says physicist Richard Wagner](#) of the Vienna University of Technology. "If we want to test macroscopic realism, then we need an object that is macroscopic in a certain sense, i.e. that has a size comparable to the size of our usual everyday objects."

In order to achieve this, the space between the two parts of the neutron beam in the interferometer is on a scale that's more macro than quantum.

"Quantum theory says that every single neutron travels on both paths at the same time," [says physicist Niels Geerits](#) of the Vienna University of Technology. "However, the two partial beams are several centimeters apart. In a sense, we are dealing with a quantum object that is huge by quantum standards."

Using several different measurement methods, the researchers probed the neutron beams at different times. And, sure enough, the measurements were too closely correlated for the classical rules of macro reality to be at play. The neutrons, their measurements suggested, were actually traveling simultaneously on two separate paths, separated by a distance of several centimeters.

It's just the latest in a [long string of Leggett-Garg experiments](#) that show we really do need quantum theory in order to describe the Universe we live in.

"Our experiment shows: Nature really is as strange as quantum theory claims," [says physicist Stephan Sponar](#) of the Vienna University of Technology. "No matter which classical, macroscopically realistic theory you come up with: It will never be able to explain reality. It doesn't work without quantum physics."

The research has been published in [Physical Review Letters](#).

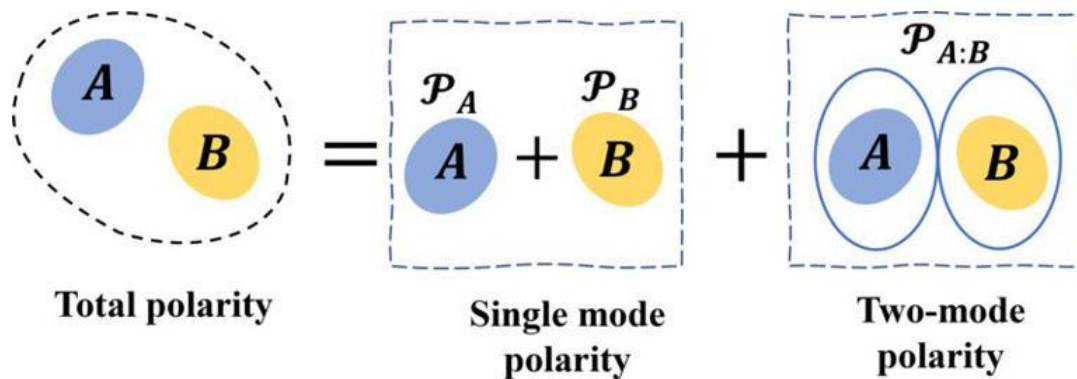

Total classical-nonclassical polarity of a two-mode Gaussian state. Credit: Physical Review Letters (2024). DOI: 10.1103/PhysRevLett.132.240201

The foundation of nearly all quantum information applications—such as computation and communication—rely on the quantum properties of superposition and entanglement.

In quantum computers—which hold the promise of performing complex calculations that today's classical computers can't handle—superposition and entanglement go hand in hand. While superposition allows a physical system—like a particle—to be in multiple states simultaneously, entanglement links particles, allowing them to form an inseparable state, even when they are separated by a large distance.

"They are the fundamental properties of quantum mechanics, the determining properties for many applications," said Wenchao Ge, assistant professor of physics at the University of Rhode Island, whose theoretical research explores fundamental issues in quantum mechanics. "Without superposition and entanglement, no quantum-enhanced application would exist."

In recent theoretical research, Ge and collaborators Jiru Liu and M. Suhail Zubairy, members of the Institute for Quantum Science and Engineering at Texas A&M University, explored the relationship between the two fundamental resources to quantum physics.

They established a single way to quantify the two properties, defining a mathematical description of each. Their paper, "Classical-Nonclassical Polarity of Gaussian States," was [published](#) in *Physical Review Letters*.

"It's theoretical proof that the two properties—superposition and entanglement—can be interchanged quantitatively," said Ge. "Our work discovers an important quantitative relation between these two fundamental quantum effects for a large class of quantum states. This work opens a new direction of research in quantifying these resources for quantum information processing."

The ability to quantify the properties allows for the conversion of these two resources from one state to the other. "Sometimes in quantum mechanics, one resource may be difficult to prepare," said Ge. "If you could have the other type of resource, you can convert between these resources."

In the field of quantum mechanics, there has been interest in understanding and application of nonclassical resources—resources that do not have a classical counterpart, such as a particle in a state with a negative probability. But research has fallen short in coming up with a satisfactory unified evaluation of both properties, Ge said.

The researchers wanted to explore the internal relationship between the two quantum properties, which determine many high-level quantum applications such as computation, communication and sensing. To do so, they looked at Gaussian states, a large class of states in quantum mechanics known for their ease in reproducing and manipulation during quantum information experiments.

Previous studies have looked at quantitative relationships of the two properties for two-mode or three-mode (two or three particle) Gaussian states. The team advanced the research, proposing a single measure for quantum superposition in one-particle systems and entanglement between multiple particles (two or three particle modes).

The new measure, "classical-nonclassical polarity," is shown to unify the two effects quantitatively for a large class of Gaussian states, Ge said.

Ge said the work can form a foundation for exploring other quantum properties for information applications such as quantum sensing and computing.

"This is the first step in finding a quantitative relation between these two properties," said Ge. "For Gaussian states, we have only proved this relationship up to three modes. It may be useful to study four, five or even more bipartite. We conjecture such a quantitative relation even beyond Gaussian states."

"For physics research, we want to see what are the properties, what are the fundamental principles," he added. "If we discover a fundamental principle, there could be far-reaching applications."

More information: Jiru Liu et al, Classical-Nonclassical Polarity of Gaussian States, *Physical Review Letters* (2024). DOI: [10.1103/PhysRevLett.132.240201](https://doi.org/10.1103/PhysRevLett.132.240201). On arXiv: [DOI: 10.48550/arxiv.2310.12104](https://doi.org/10.48550/arxiv.2310.12104)

Berislav Buca has developed a new theory that enables the calculation of the dynamics, i.e., movements and interactions, of systems with enormous quantities of [quantum](#) particles.

This feat was previously thought to be impossible. The research, published in the journal *Physical Review X*, has reinvigorated an old and fundamental scientific question: Can we predict everything by calculating its [smallest particles](#)?

"Many physics disciplines are ultimately about explaining and predicting the world by understanding the laws of physics and calculating the behavior of the smallest particles," says Buca, a researcher at the University of Copenhagen's [Niels Bohr Institute](#).

"In principle, we would be able to answer any possible question about how all sorts of things behave if we were able to," Buca noted.

Complexity of quantum particles

Despite the potential of this research, Buca quickly appeals for caution. "Of course I can't do that," says the theorist.

The interactions and movements of quantum particles in their systems are so complex that even the world's most powerful supercomputer today is only able to [perform calculations](#) on a dozen of these particles at a time.

"So in practice, it isn't possible. Not currently. However, my theory is a significant step in the right direction," Buca explained.

"This is because it takes a kind of mathematical shortcut to understanding the dynamics of the whole, without [computing power](#) being lost in the details for a broad class of systems with many quantum particles. That is, without the need to calculate all of the individual particles in a system," he continued.

Proving a long-held hypothesis

Buca's theory has already made a name for itself by providing the first mathematical proof of a long-held hypothesis in theoretical physics.

The eigenstate-thermalization hypothesis, which concerns the ability of mathematics to describe the motions of quantum systems as wholes, had been an assumption -- an educated guess -- in physics that had yet to be explained mathematically.

Quantum particles as keys to revolutionary technologies

While the results mainly interest the bright minds of physics for now, the consequences could eventually be great for us all.

This knowledge could end up showing the way to sought for quantum materials with properties so unique that they could transform our world.

"We are looking for a material for [quantum computers](#) that can withstand entropy -- a law of nature that causes complex systems -- e.g., materials -- to decay into less complex forms. Entropy destroys the coherence needed for quantum computers to be stable and keep working," Buca explains.

Simplifying quantum systems with exotic math

The exotic math systems that initially inspired Buca and made his research breakthrough possible may be just what a quantum computer needs to be truly useful.

"The so-called qubits that a [quantum computer](#) theoretically works with must be in a state of superposition to function, meaning that they are simultaneously turned on and off -- in common phrasing," Buca says.

"This requires them to be in a stable quantum state. However, thermodynamics does not like the structures required by the current materials. My theory may be able to inform us whether these exotic systems can be a way of structuring things so this quantum state could be more permanent," he concluded.

Road map for quantum particle discoveries

Buca's method is a bit like a road map that can guide researchers across a vast landscape of possible materials by allowing for predictions of how these materials would behave under experimental conditions.

For the first time, this gives researchers a way to target their search for [quantum materials](#) equipped with special properties.

"Until now, the hunt for these materials has been governed by chance. But my results can, for the first time, provide a guiding principle to navigate by when searching for unique properties in materials," says Buca.

Dawn of a potential new era in quantum physics

In summary, Berislav Buca's mind-bending theory opens up new possibilities in the field of theoretical physics and quantum computing.

By providing a mathematical shortcut to calculate the dynamics of quantum systems, Buca has proven a long-held hypothesis and paved the way for targeted searches of quantum materials with unique properties.

This research could lead to the development of stable quantum computers and room-temperature superconductors, revolutionizing our understanding of the universe and transforming our world.

As scientists continue to explore the implications of this breakthrough, we stand at the precipice of a new era in quantum physics, eagerly anticipating the exciting discoveries and innovations that lie ahead.

The full study was published in the journal [*Physical Review X*](#).

My new article, "Quantum Entanglement of Optical Photons: The First

Experiment, 1964–67," is intended to convey the spirit of a small research project that reaches into uncharted territory. The article breaks with tradition, as it offers a first-person account of the strategy and challenges of the experiment, as well as an interpretation of the final result and its significance. In this guest editorial, I will introduce the subject and also attempt to illuminate the question "What is a paradox?"

Let's begin with the gyroscope that I bought when I was eight, from a store that sold novelties and magic tricks. The spinning disk, supported at one end of its shaft, did not fall, but moved slowly around in a horizontal plane. This behavior seems mysterious or paradoxical in the context of common experience that excludes gyroscopes, but makes complete sense in the context of Newtonian mechanics, which resolves the paradox by predicting precisely how gyroscopes will behave.

Quantum theory, conceived in the mid-1920s, has been impressively successful in accounting for the properties and interactions of atoms and molecules. In 1935, Einstein, Podolsky, and Rosen stirred controversy with a thought experiment in which two particles of common origin move apart, noting that quantum theory

predicts correlations in subsequent measurements of their spins. The correlation may seem quite puzzling, as a measurement on one of the particles appears to influence a subsequent measurement on the other, even if the particles do not interact.

In current terminology, these correlations are an example of entanglement, and the correlation phenomenon is known as the EPR paradox. The puzzle has become a subject for much discussion and analysis, especially because there was (and is) no known mechanism for measurements to communicate with each other.

Disentangling entanglement

In 1964, I was intrigued by this unfamiliar effect and began to think of a way to actually perform the EPR experiment—or at least a version of it— by observing the correlation and entanglement. It would be a low-energy experiment that could be set up in a small laboratory.

For the experiment outlined here, the particles of interest are visible-light photons, which are noninteracting, emitted by excited calcium atoms in a two-stage spontaneous emission process. The polarization states of the photons, which are related to their spins, can be measured simply, with ordinary linear polarizers. Photomultiplier detectors count the individual photons, #1 (green) and #2 (violet), and timing circuits enable the identification of photon pairs from the same atom. A rotatable linear polarizer is mounted in front of each detector.

In the simplest terms, the experiment involves counting the rate at which photon pairs are detected, as a function of the orientation of the polarizers. A photon pair detected from the same atom is recorded as a "coincidence count."

Quantum theory makes the following predictions:

1. Each photon, taken separately, has a 50% chance of being transmitted by its polarizer, regardless of its angle of orientation.

2. If the polarizer axes are parallel, both photons from the same atom can pass through their polarizers and be counted. Coincidence counts will be observed.
3. If the polarizer axes are perpendicular, it never happens that both photons pass through their polarizers. Therefore, no coincidence counts will be observed.

Predictions #1 and #2 are not surprising, as the green and violet beams of light are unpolarized.

Prediction #3, discussed further in my article, is a quantum entanglement effect with no analog in classical (non-quantum) physics. It is especially interesting because it can be tested experimentally. I designed the experiment specifically for this purpose.

The results of the experiment, after nearly three years of effort in the laboratory, clearly demonstrate that coincidence counts are recorded if the polarizer axes are parallel, and that no coincidences are recorded if the polarizers are perpendicular. The agreement between theory and experiment is unequivocal and striking.

So, is there a paradox?

In our brief discussion of the gyroscope, no paradox was acknowledged because Newton's theory (classical dynamics) fully explains how a gyroscope moves. Furthermore, both the theory and the observed gyroscopic behavior are compatible with our life experience and intuitive ability to grasp natural processes in the classical realm.

In the entanglement case, quantum theory accounts for the observed correlation of the photon polarizations. But even when a theory predicts experimental results, a paradox may remain if the intuition cannot reach out to connect with it.

Take another look at predictions #1 and #3 above. If we draw on our experience of life in a non-quantum world, we may notice something very strange when the polarizers are "crossed" at 90 degrees. If each photon has a 50% chance of

transmission through its polarizer, why don't we get coincidences 25% of the time? Instead, we observe none at all.

On first consideration, this does seem to qualify as a paradox. One possible explanation could involve a missing component of quantum theory—perhaps a causal mechanism that could allow one photon, or one measurement, to communicate with the other. However, despite extensive research, no evidence has been found for such a mechanism.

As we do not live in an overtly quantum world, classical phenomena may influence our thought processes—even when we venture into the quantum realm. It may therefore remain a challenge to assimilate entanglement into the intuition. I believe that the paradox can be at least partially resolved when further thought and experience, such as the experiment considered here, 'stretch the mind' to more fully embrace entanglement and other quantum phenomena.

I have come to view these aspects of nature as "strangely wonderful."

More information: Quantum Entanglement of Optical Photons: The First Experiment, 1964-67, *Frontiers in Quantum Science and Technology* (2024). [DOI: 10.3389/frqst.2024.1451239](https://doi.org/10.3389/frqst.2024.1451239)

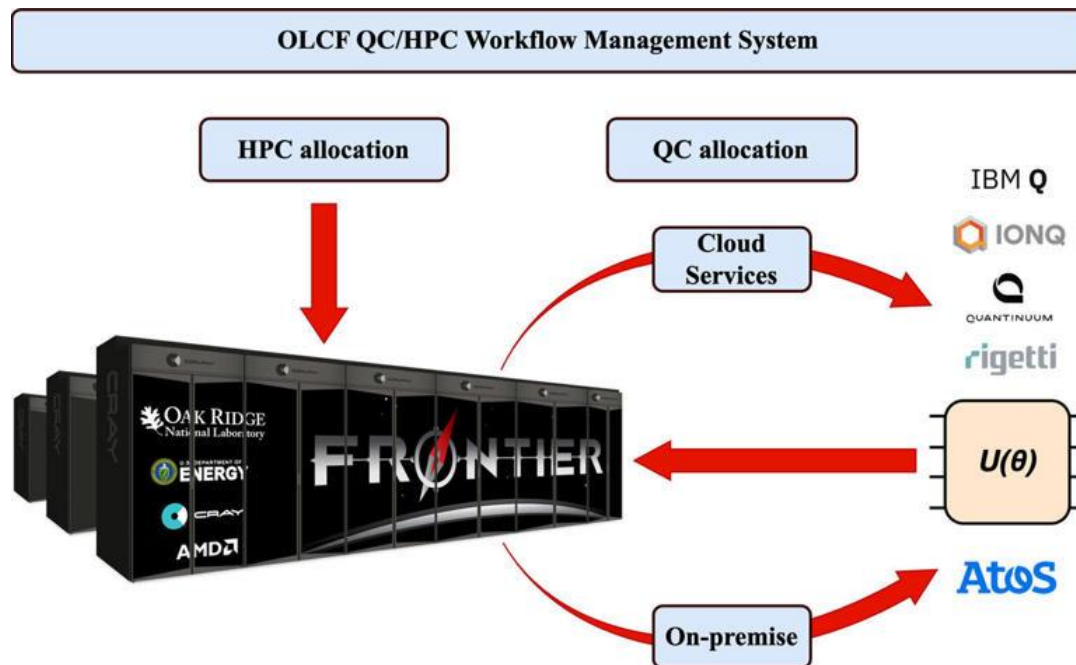

Schematic of the QC/HPC integration at OLCF. This is a high-level view of the ideal state of the framework presented in Section 8. The framework will integrate simulators, cloud-based quantum devices, and on-premises quantum hardware in a seamless way. Credit: Future Generation Computer Systems (2024). DOI: 10.1016/j.future.2024.06.058

A study by more than a dozen scientists at the Department of Energy's Oak Ridge National Laboratory examines potential strategies to integrate quantum computing with the world's most powerful supercomputing systems in the pursuit of science.

The study [published](#) in *Future Generation Computing Systems* takes a big-picture look at the states of quantum computing and classical high-performance computing, or HPC, and describes a potential framework for boosting traditional scientific HPC by leveraging the quantum approach.

"It's kind of a manifesto for how we propose to dive as a laboratory into this new era of computing," said co-author Rafael Ferreira da Silva, a senior research scientist for ORNL's National Center for Computational Sciences, or NCCS. "Our approach won't be the only right way, but we think it will be a useful one that builds on ORNL's legacy as a leader in supercomputing and that we can adapt as technology evolves and the next generation of computing takes shape."

ORNL serves as home to the Oak Ridge Leadership Computing Facility, or OLCF, which houses Frontier, the world's fastest supercomputer, and to the OLCF Quantum Computing User Program, which awards time on privately owned quantum processors around the country to support independent quantum study. The laboratory also leads the DOE's Quantum Science Center, a national Quantum Information Science Research Center, which combines resources and expertise from national laboratories, universities and industry partners to investigate quantum computing, quantum sensing and quantum materials.

China: China on verge of brain-computer interface commercialization

"We have a vast amount of experience here at ORNL in standing up classical supercomputers, dating back more than 20 years," said Tom Beck, the study's lead author, who oversees the NCCS Science Engagement Section. "How can we

apply that experience and maintain that momentum as we explore this new quantum domain?"

Classical computers store information in bits equal to either 0 or 1. In other words, a classical bit, like a light switch, exists in one of two states: on or off. That binary dynamic doesn't necessarily fit some complex scientific problems.

"We encounter certain problems in science in which electrons, for example, are coupled between atoms in ways that grow exponentially when we try to model them on a classical computer," Beck said. "We can adjust formulas and try to tackle those problems in an abbreviated fashion, but we can't even begin to hope to solve them on a classical computer. The necessary equations and computations are just too complex."

Quantum computing uses the laws of quantum mechanics to store information in qubits, the quantum equivalent of bits. Qubits can exist in more than one state simultaneously via quantum superposition, which allows qubits to carry more information than classical bits.

Quantum superposition allows a qubit to exist in two possible states at the same time, similar to a spinning coin—neither heads nor tails for the coin, neither one value nor the other for the qubit. Measuring the value of the qubit determines the probability of measuring either of the two possible values, similar to stopping the coin on heads or tails. That dynamic allows for a wider range of possible values, more like a dial with precise settings than a binary on-off switch.

"The quantum aspect allows us to represent the problem in a more efficient way and potentially opens up a new way to solve problems that we couldn't before," Beck said.

Scientists haven't yet settled on the most effective technology for encoding qubits, and high error rates remain an obstacle to harnessing quantum computing's potential. The study proposes developing quantum test beds to explore the various technologies and coupling those test beds with classical machines.

"We don't want to tie ourselves to any single technology yet because we don't know what approach will emerge as the best," Beck said. "But while we're in this

early stage, we need to begin incorporating quantum elements into our computing infrastructure with an eye toward potential breakthroughs.

"Ultimately, we want to connect these two vastly different types of computers in a seamless way to run the machines together—similar to the hybrid architecture of graphics processing units, or GPUs, and central processing units, or CPUs, that accelerates current leadership-class supercomputers."

That hybrid architecture, used by supercomputers such as Frontier, integrates the two kinds of processors on each node for the fastest possible computing—GPUs for the repetitive calculations that make up the backbone of most simulations and CPUs for higher-level tasks such as retrieving information and executing other instructions. The technology needed for classical and quantum processors to share space on a node doesn't yet exist.

The study recommends a high-speed network as the best way to connect classical HPC resources with quantum computers for now.

"There are degrees of integration, and we won't achieve the ideal right away," said ORNL's Sarp Oral, who oversees the NCCS Advanced Technologies Section. "To achieve that ideal, we need to identify which algorithms and applications can take advantage of quantum computing. Our job is to provide better ways to conduct science, and quantum computing can be a tool that serves that purpose."

More information: Thomas Beck et al, Integrating quantum computing resources into scientific HPC ecosystems, *Future Generation Computer Systems* (2024). [DOI: 10.1016/j.future.2024.06.058](https://doi.org/10.1016/j.future.2024.06.058)

Bartosz Regula from the RIKEN Center for Quantum Computing and Ludovico

Lami from the University of Amsterdam have shown, through probabilistic calculations, that there is indeed, as had been hypothesized, a rule of entropy for the phenomenon of quantum entanglement.

This finding could help drive a better understanding of quantum entanglement, which is a key resource that underlies much of the power of future quantum

computers. Little is currently understood about the optimal ways to make effective use of it, despite it being the focus of research in quantum information science for decades.

The second law of thermodynamics, which says that a system can never move to a state with lower entropy, or order, is one of the most fundamental laws of nature, and lies at the very heart of physics. It is what creates the "arrow of time," and tells us the remarkable fact that the dynamics of general physical systems, even extremely complex ones such as gases or black holes, are encapsulated by a single function, its entropy.

There is a complication, however. The principle of entropy is known to apply to all classical systems, but today we are increasingly exploring the quantum world.

We are now going through a quantum revolution, and it becomes crucially important to understand how we can extract and transform the expensive and fragile quantum resources. In particular, quantum entanglement, which allows for significant advantages in communication, computation, and cryptography, is crucial, but due to its extremely complex structure, efficiently manipulating it and even understanding its basic properties is typically much more challenging than in the case of thermodynamics.

The difficulty lies in the fact that such a "second law" for quantum entanglement would require us to show that entanglement transformations can be made reversible, just like work and heat can be interconverted in thermodynamics.

It is known that reversibility of entanglement is much more difficult to ensure than the reversibility of thermodynamic transformations, and all previous attempts at establishing any form of a reversible theory of entanglement have failed. It was even suspected that entanglement might actually be irreversible, making the quest an impossible one.

In their new work, [published in *Nature Communications*](#), the authors solve this long-standing conjecture by using probabilistic entanglement transformations, which are only guaranteed to be successful some of the time, but which, in return, provide an increased power in converting quantum systems.

Under such processes, the authors show that it is indeed possible to establish a reversible framework for entanglement manipulation, thus identifying a setting in

which a unique entropy of entanglement emerges and all entanglement transformations are governed by a single quantity. The methods they used could be applied more broadly, showing similar reversibility properties also for more general quantum resources.

According to Regula, "Our findings mark significant progress in understanding the basic properties of entanglement, revealing fundamental connections between entanglement and thermodynamics, and crucially, providing a major simplification in the understanding of entanglement conversion processes.

"This not only has immediate and direct applications in the foundations of quantum theory, but it will also help with understanding the ultimate limitations on our ability to efficiently manipulate entanglement in practice."

Looking toward the future, he continues, "Our work serves as the very first evidence that reversibility is an achievable phenomenon in entanglement theory. However, even stronger forms of reversibility have been conjectured, and there is hope that entanglement can be made reversible even under weaker assumptions than we have made in our work—notably, without having to rely on probabilistic transformations.

"The issue is that answering these questions appears significantly more difficult, requiring the solution of mathematical and information-theoretic problems that have evaded all attempts at solving them thus far. Understanding the precise requirements for reversibility to hold thus remains a fascinating open problem."

More information: Bartosz Regula et al, Reversibility of quantum resources through probabilistic protocols, *Nature Communications* (2024). [DOI: 10.1038/s41467-024-47243-2](https://doi.org/10.1038/s41467-024-47243-2)

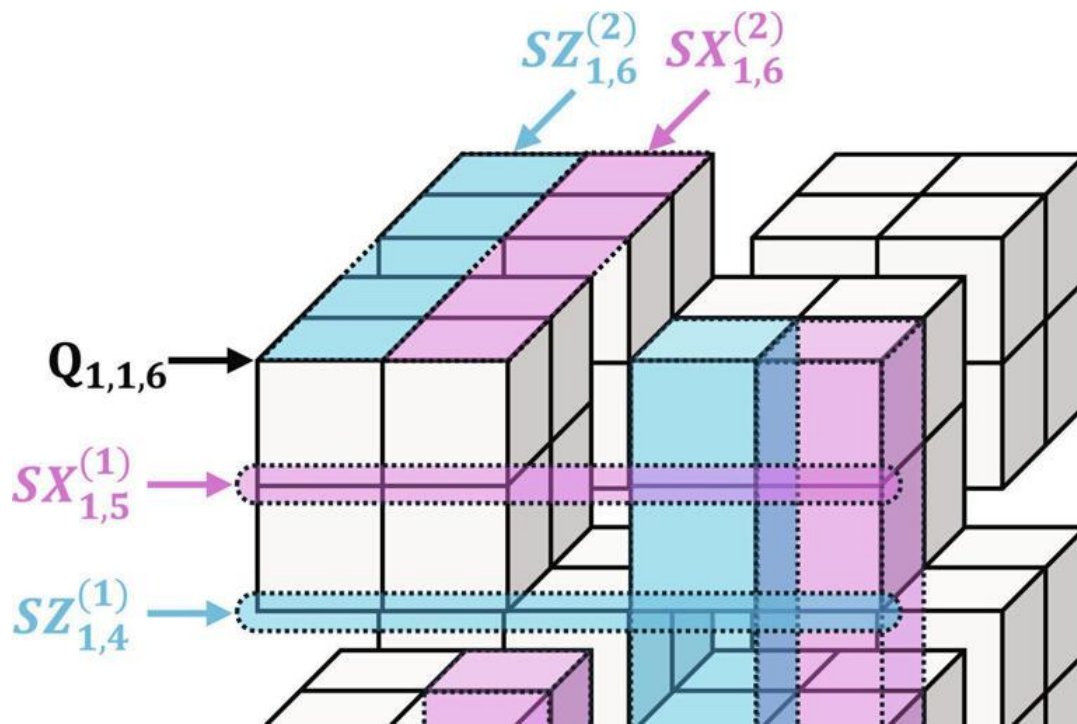

Visualization of the structure of the level-3 many-hypercube code. Credit: Science Advances (2024). DOI: 10.1126/sciadv.adp6388

In work [published](#) in *Science Advances*, Hayato Goto from the RIKEN Center for Quantum Computing in Japan has proposed a new quantum error correction approach using what he calls "many-hypercube codes."

This approach, which turns out to have an elegant geometry, could help realize extremely efficient error corrections and contribute to highly parallel methods that will allow fault-tolerant quantum computing, the next stage in the evolution of quantum computers.

According to Goto, "Thanks to recent experimental progress, there is now great hope that we will be able to build fault-tolerant quantum computers, meaning quantum computers that can correct errors and surpass the power of conventional computers on certain tasks. To achieve this, however, it is important to develop efficient quantum error correction."

Scientists have proposed many different methods of error correction over the last several decades. The conventional approach to quantum error correction is

typically based on encoding a single logical qubit—the qubit being the equivalent of a bit on a classical computer—onto many entangled physical ones, and then using a decoder to retrieve the logical qubit from the physical ones.

However, scalability is a problem with this approach, since the number of physical qubits required goes up enormously, and this results in huge resource overheads. To overcome this problem, high-rate quantum codes, such as quantum low-density parity-check codes, have been considered.

With this approach, the logical gates, which make calculations possible, have to be set up quite sequentially rather than fully parallel, making them less efficient time-wise.

As a means to remedy this, Goto proposed using an approach that he calls "many-hypercube codes." Specifically, it is a method with a complex name—high-rate concatenated quantum codes—and what is innovative is that the logical qubits can be visualized mathematically as forming what is known as a "hypercube"—a type of shape, including squares and cubes as well as higher-order shapes such as the tesseract.

The beautiful mathematical and geometric structure of the code is remarkable, as most high-rate quantum codes have complicated structures.

Goto emphasizes that in order for the new codes to result in higher performance, he needed to develop a novel dedicated decoder that could interpret the result from the physical qubits. This innovative technique is based on level-by-level minimum distance decoding, which allows for high performance.

Unlike other similar methods, it also allows for logical gates to be put in parallel rather than in a series, which makes the system analogous to parallel processing in classical computers, leading Goto to call it "high-performance fault tolerant computing" as an analogy to "high-performance computing" which is used for massively parallel computing.

The work paid off. The codes achieve an encoding rate—a number that indicates the ratio between logical and physical qubits—of up to 30% which Goto says appears to be the world's highest among the codes used for fault-tolerant quantum computing. And even with this high rate, the performance is comparable to conventional low-rate codes.

Goto says, "In practice, this code could be implemented with physical qubit systems such as laser-trapped neutral-atom qubits."

More information: Hayato Goto, High-performance fault-tolerant quantum computing with many-hypercube codes, *Science Advances* (2024). [DOI: 10.1126/sciadv.adp6388](https://doi.org/10.1126/sciadv.adp6388)

There has been significant progress in the field of quantum computing. Big global players, such as Google and IBM, are already offering cloud-based quantum computing services. However, quantum computers cannot yet help with problems that occur when standard computers reach the limits of their capacities because the availability of qubits or quantum bits, i.e., the basic units of quantum information, is still insufficient.

One of the reasons for this is that bare qubits are not of immediate use for running a quantum algorithm. While the binary bits of customary computers store information in the form of fixed values of either 0 or 1, qubits can represent 0 and 1 at one and the same time, bringing probability as to their value into play. This is known as quantum superposition.

This makes them very susceptible to external influences, which means that the information they store can readily be lost. In order to ensure that quantum computers supply reliable results, it is necessary to generate a genuine entanglement to join together several physical qubits to form a logical qubit. Should one of these physical qubits fail, the other qubits will retain the information. However, one of the main difficulties preventing the development of functional quantum computers is the large number of physical qubits required.

Advantages of a photon-based approach

Many different concepts are being employed to make quantum computing viable. Large corporations currently rely on superconducting solid-state systems, for example, but these have the disadvantage that they only function at

temperatures close to absolute zero. Photonic concepts, on the other hand, work at room temperature.

Single photons usually serve as physical qubits here. These photons, which are, in a sense, tiny particles of light, inherently operate more rapidly than solid-state qubits but, at the same time, are more easily lost. To avoid qubit losses and other errors, it is necessary to couple several single-photon light pulses together to construct a logical qubit—as in the case of the superconductor-based approach.

A qubit with the inherent capacity for error correction

Researchers of the University of Tokyo together with colleagues from Johannes Gutenberg University Mainz (JGU) in Germany and Palacký University Olomouc in the Czech Republic have recently demonstrated a new means of constructing a photonic quantum computer. Rather than using a single photon, the team employed a laser-generated light pulse that can consist of several photons. The research is [published](#) in the journal *Science*.

"Our laser pulse was converted to a quantum optical state that gives us an inherent capacity to correct errors," stated Professor Peter van Loock of Mainz University. "Although the system consists only of a laser pulse and is thus very small, it can—in principle—eradicate errors immediately." Thus, there is no need to generate individual photons as qubits via numerous light pulses and then have them interact as logical qubits.

"We need just a single light pulse to obtain a robust logical qubit," added van Loock. To put it in other words, a physical qubit is already equivalent to a logical qubit in this system—a remarkable and unique concept. However, the logical qubit experimentally produced at the University of Tokyo was not yet of a sufficient quality to provide the necessary level of error tolerance. Nonetheless, the researchers have clearly demonstrated that it is possible to transform non-universally correctable qubits into correctable qubits using the most innovative quantum optical methods.

More information: Shunya Konno et al, Logical states for fault-tolerant quantum computation with propagating light, *Science* (2024). DOI: [10.1126/science.adk7560](https://doi.org/10.1126/science.adk7560)

Olivier Pfister, Qubits without qubits, *Science* (2024). DOI: [10.1126/science.adm9946](https://doi.org/10.1126/science.adm9946)

Provided by Johannes Gutenberg University Mainz



Prototype quantum processor hits record 99.9% qubit fidelity in a major milestone

A Finland-based firm that develops, builds and sells superconducting quantum computers, has achieved significant milestone and showcased improvements in two key metrics characterising the quality of quantum computer.

IQM Quantum Computers achieved a record low error rate for two-qubit operations. It demonstrated a CZ gate between two qubits with $(99.91 \pm 0.02) \%$ fidelity, which was validated by interleaved randomised benchmarking.

Achieving high two-qubit gate fidelity is the most fundamental and hardest to achieve characteristic of a quantum processor. It's also essential for generating

entangled states between qubits and executing algorithms, according to the company.

Achievement to help develop stable quantum computers

The achievement marks a way toward “fault-tolerant” quantum computing as it achieved record-low error rates in prototype quantum computer. It’s also expected to lead to the development of more stable quantum computers.

IQM [maintains](#) that [qubit](#) relaxation time T1 of 0.964 +- 0.092 milliseconds and dephasing time T2 echo of 1.155 +- 0.188 milliseconds was demonstrated on a planar transmon qubit on a silicon chip fabricated in IQM’s own fabrication facilities.

The coherence times, characterized by the relaxation time T1 and the dephasing time T2 echo, are among the key metrics for assessing the performance of a single qubit, as they indicate how long quantum [information](#) can be stored in a physical qubit, according to the company.

IQM’s fabrication technology has matured

“These major results show that IQM’s fabrication technology has matured and is ready to support the next generation of IQM’s high-performance quantum processors,” said IQM in a [press release](#).

“The results follow IQM’s recent [benchmark](#) announcements and indicate significant potential for further advancements on gate fidelities essential for fault-tolerant quantum computing and processors with higher qubit counts.”

High fidelity in [two-qubit](#) gates are key for generating entangled states — when qubits become interconnected in such a way that the state of one directly affects the state of the other, regardless of the distance between them. Quantum

entanglement is a cornerstone of quantum mechanics, what Einstein dubbed “spooky action at a distance”, reported [Live Science](#).

Achievement cements IQM’s tech leadership

“This achievement cements our tech leadership in the industry. Our quantum processor quality is world-class, and these results show that we have a good opportunity of going beyond that,” said Dr. Juha Hassel, the Vice President of Engineering at IQM Quantum Computers.

Hassel claims that IQM is on track with its technology roadmap and is actively exploring potential use cases in machine learning, cybersecurity, route optimization, sensor simulation, chemistry, and pharmaceutical research.

The improvements made in the two characteristics, two-qubit gate fidelity and coherence time, allow the quantum computer to be developed for more complex use cases, according to the company. The significance of these results stems from the fact that only very few organizations have achieved comparable performance numbers before, according to the company.



At the Garching campus, TUM researchers are helping to shape the era of quantum technology. Credit: Kai Neunert / BAdW© Provided by Phys.org

Electrons that spin to the right and the left at the same time. Particles that change their states together, even though they are separated by enormous distances. Intriguing phenomena like these are completely commonplace in the world of quantum physics. Researchers at the TUM Garching campus are using them to build quantum computers, high-sensitivity sensors and the internet of the future.

"We cool the chip down to only a few thousandths of a degree above absolute zero—colder than in outer space," says Rudolf Gross, Professor of Technical Physics and Scientific Director of the Walther Meissner Institute (WMI) at the Garching research campus. He's standing in front of a delicate-looking device with gold-colored disks connected by cables: The cooling system for a special chip that utilizes the bizarre laws of quantum physics.

For about twenty years now, researchers at WMI have been working on quantum computers, a technology based on a scientific revolution that occurred 100 years ago when quantum physics introduced a new way of looking at physics. Today it serves as the foundation for a "new era of technology," as Prof. Gross calls it.

To shape this emerging era, researchers at Garching are investigating ways to utilize the rules of quantum physics, as well as the associated risks and the potential benefits of quantum technology to society.

2 Manipulating individual atoms

"We encounter quantum physics every day," says Gross. For example, when we see a stovetop burner element glowing red. In 1900 Max Planck found the formula for the radiation that bodies of different temperatures emit. This meant that he had to assume that the emitted light consists of tiny energy parcels, referred to as quanta. Quantum physics continued to develop in the years that followed, fundamentally changing our understanding of the microcosmos. New technologies exploited the special properties of atoms and electrons, for example, the laser, the magnetic resonance tomograph and the computer chip.

The technologies of this first quantum revolution control large quantities of particles. In the meantime, physicists can also manipulate individual atoms and photons and can produce objects that obey the laws of quantum physics. "Today we can create tailor-made quantum systems," says Gross. The principles of quantum physics, for which there as yet hardly any technological realizations, can be used in this so-called second quantum revolution.

The first of these principles is superposition: A quantum object can assume parallel states, which are mutually exclusive in the classic frame of reference. For example, an electron can rotate both to the right and to the left at the same time. The superposed states can also mutually interact, similar to intersecting waves which either reinforce one another or cancel out one another—this is the second principle: Quantum interference.

Grasping inconceivable phenomena

The third phenomenon is entanglement. Two particles can have a joint quantum state, even if they are located kilometers away from one another. For example, if we measure the polarization of a given photon, then the measurement result for the entangled partner is instantaneously ascertained as if the space between the two photons did not exist.

As exotic as these concepts may sound, they're equally important for technical progress. Classical computers have a drawback: They process information sequentially, one step at a time. "Not even supercomputers which are constantly growing faster will be able to master all the tasks at hand," says Gross, since the complexity of some tasks can increase drastically.

For example, the number of possible travel routes between several cities increases with each potential stop. There are six possible routes between four cities, while for 15 cities the number is more than 40 billion. Thus, the task of finding the shortest route very quickly becomes overwhelmingly complex, even unsolvable, using classical computers within a viable amount of time.

The principle of superposition makes the task much easier for the quantum computer: It uses quantum bits, or qubits, which can process the bit values 0 and

1 simultaneously instead of sequentially. A large number of qubits, linked with one another by quantum interference or entanglement, can process an inconceivably large number of combinations in parallel and can thus solve highly complex tasks very quickly.

Qubits: Tiny circuits

Back to WMI: Here we find silver vacuum chambers in which metal atoms are precisely deposited on hand-sized silicon wafers. The highly pure metal layers forming on these wafers form the basis for tiny circuits. When supercooling makes the circuits superconductive, the electricity they carry oscillates at various frequencies corresponding to different energy levels. The two lowest levels serve as the qubit values 0 and 1. The chip in one of these cooling systems contains six qubits, sufficient for research purposes.

However, quantum computers need several hundred qubits in order to solve practical problems. In addition, each one of the qubits should be able to perform as many computational steps as possible in order to realize algorithms that are relevant for practical purposes. But qubits lose their superposition very quickly, even after the slightest disturbance, such as material defects or electrosmog—"an enormous problem," says Gross.

Complex correction procedures must then be used to correct these errors, but these processes will require thousands of additional qubits. Experts expect that this will take many years to achieve. Nevertheless, initial applications could already be functional when the number of qubit errors is reduced, if not eliminated.

"One important error source is unwanted mutual interaction between qubits," says Dr. Kirill Fedorov of the WMI. His remedy: Distributing qubits across several chips and entangling them with one another. In the basement of the WMI Fedorov points to a tube with the diameter of a tree branch leading from one quantum computer to the next. The tubes contain microwave conductors which put the qubits into mutual interaction with one another. This approach could make it possible for thousands of qubits to work together in the future.

Hypersensitive quanta measure more precisely

Eva Weig, Professor of Nano and Quantum Sensor Technology, has a different perspective on this lack of perfection. "The fact that quantum states react so sensitively to everything can also be an advantage," she says. Even the most minute magnetic fields, pressure variations or temperature fluctuations can measurably change a quantum state. "This can make sensors more sensitive and more precise and make them capable of better spatial resolution," says Weig.

She wants to use relatively large objects as mechanical quantum sensors. Even nanostructures consisting of millions of atoms can be put into their quantum ground state, as researchers at the University of California first demonstrated in 2010. Eva Weig is building on the finding. "I want to construct easily controlled nanosystems in order to measure the smallest forces."

In the laboratory, the physicist presents a chip her team made in its own cleanroom. On it are what she calls "nano-guitars," invisible to the naked eye: Tiny strings, 1,000 times thinner than a human hair, which vibrate at radio frequency. Weig's team is attempting to put these nano-oscillators into a defined quantum state. Then the strings could be used as quantum sensors, for example in measuring the forces existing between individual cells.

The road to the quantum internet

Professor of Quantum Networks Andreas Reiserer wants to use another aspect of quantum systems in order to facilitate a quantum internet: The quantum state of a particle is destroyed when it is measured, meaning that the information it contains can only be read out once. Thus any attempt at interception would inevitably leave behind traces. If there are no such traces, a communication can then be trusted. "Quantum cryptography is cost-effective and can already support interception-proof communication today," he says.

But the scope of this technology still remains limited. According to Reiserer, fiber optic elements are ideal for transporting quantum information using light. But

the glass absorbs some of the light in every kilometer it travels. After about 100 kilometers, communication is no longer possible.

Reiserer's team is therefore conducting research into what are called quantum repeaters, storage units for quantum information which are to be spaced out along the fiber optical network approximately every 100 kilometers. If it is possible to entangle each of the quantum repeaters with its immediate neighbor, then information sent can be passed on without any loss. "This way we hope to be able to traverse global-scale distances," Reiserer says. "Then it could be possible to link devices everywhere around the world to form a 'quantum supercomputer.'"

The Munich-based team wants to miniaturize quantum repeaters, to simplify them and make them suitable for mass production by putting them onto a computer chip. The chip contains an optical fiber in which erbium atoms have been embedded. These atoms serve as qubits which can buffer the information. However, Reiserer admits, this requires cooling to as little as four degrees Kelvin (i.e., approximately -269°C) and adds that a lot more research will be necessary before practical viability is achieved.

Societal risks

The arrival of quantum technologies in everyday life also entails some risks. An error-corrected quantum computer could crack today's conventional encryption procedures and could for example compromise online banking security. "The good news is that there are already new encryption procedures which are secure against quantum computer attacks," says Urs Gasser, Professor of Public Policy, Governance and Innovative Technology and head of the "Quantum Social Lab" at TUM. Gasser, a legal scholar, adds that the transition will take several years, making it necessary to get started now.

"The cost of arriving too late could even outstrip the cost of being late on Artificial Intelligence," Gasser warns. The Quantum Social Lab focuses on the ethical, legal and societal impacts of emerging quantum technologies. This includes for example the question of how to integrate people in the debate

surrounding the new technology, or whether or not only wealthy countries should be able to better plan their cities thanks to quantum optimization.

"The second quantum revolution is a paradigm shift which will have a far-reaching social, political and economic impact," says Prof. Gasser. "We have to shape this revolution in the best interests of society."

Provided by Technical University Munich

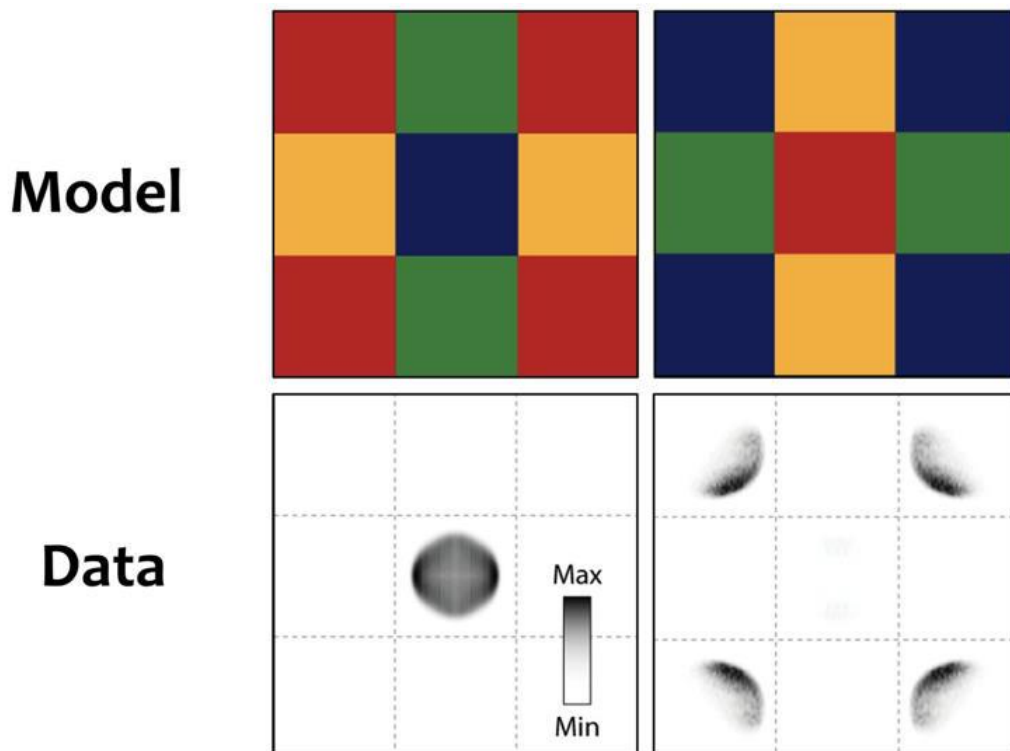

Image illustrating four-source interference, which is similar to the mechanism of condensed matter dark states Credit: Chung et al

Dark states are quantum states in which a system does not interact with external fields, such as light (i.e., photons) or electromagnetic fields. These states, which generally occur due to interferences between the pathways through which a system interacts with an external field, are undetectable using spectroscopic techniques.

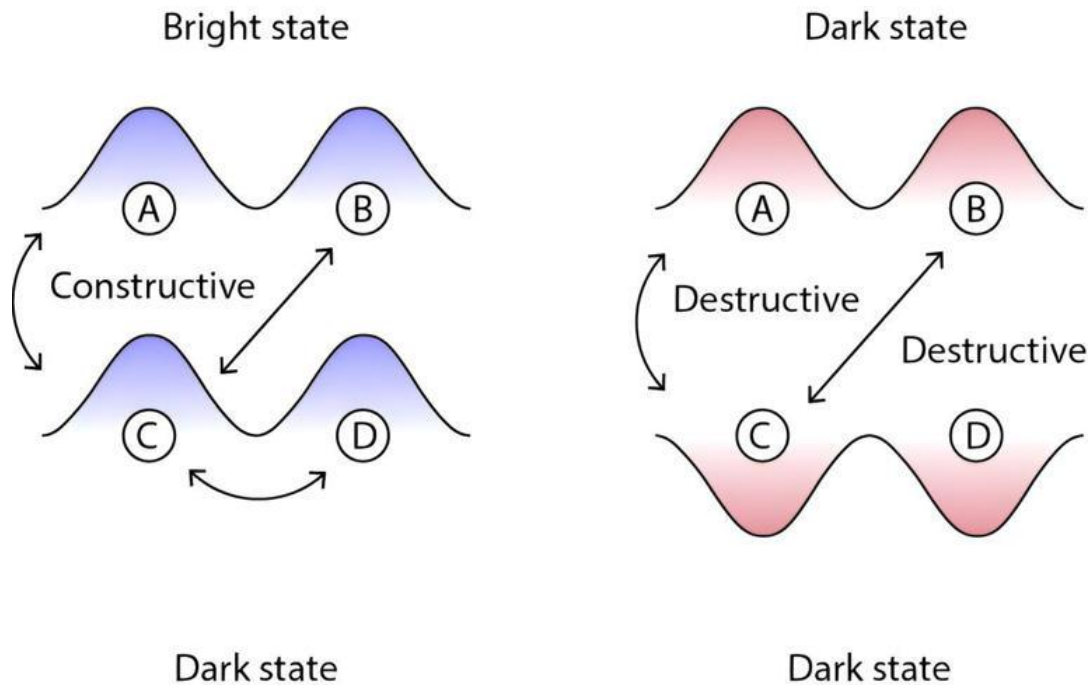

Image illustrating four kinds of electron states in solids with two pairs of sublattices indexed A, B, C, and D. Palladium diselenides, cuprate superconductors and lead halide perovskites have unique crystal symmetries known as multiple glide-mirror symmetries. These symmetries make all the electrons simplified into only four kinds shown in blue, red, yellow, and green in the picture. The blue is only the bright state, and red, yellow, and green are dark states. As you can easily identify by comparing the model and data, only the blue could be observed in angle-resolved photoemission spectroscopy. Credit: Chung et al

Researchers at Yonsei University in South Korea and other institutes recently discovered some undetectable condensed-matter dark states in palladium diselenide, a quantum system with two pairs of sublattices in its primitive cell.

Their observations, outlined in a [paper](#) published in *Nature Physics*, could have interesting implications for the study of materials, quantum states and correlated phenomena.

"Angle-resolved photoemission spectroscopy is a powerful experimental technique for physicists to understand how electrons behave in solids," Keun Su Kim, Professor of Physics at Yonsei University and co-author of the paper, told Phys.org.

"From experience, it has been well known that not all the electrons are detected by angle-resolved photoemission spectroscopy. In other words, some electrons are detectable but the others are not."

For a long time, physicists assumed that the inability to detect some electrons using spectroscopic techniques was associated with the methods used to conduct experiments, rather than the intrinsic properties of materials.

However, in previous studies examining simple elemental materials with one pair of sublattices, such as graphene and black phosphorus, Kim and his colleagues showed that this elusiveness is in fact closely linked to the intrinsic properties of materials.

"We have dug into this problem to extend it to materials with two pairs of sublattices and found that there are some electrons that cannot be detected in any experimental conditions," Kim said. "Simply speaking, we could see experimental signals only for electrons expected to be detectable (bright states) and could not see any experimental signals for electrons expected to be undetectable (dark states)."

To carry out their experiments, the researchers employed a technique known as angle-resolved photoemission spectroscopy. This widely used experimental technique leverages the photoelectric effect first discovered by Albert Einstein to gather information about the electronic structure of materials.

Essentially, Kim and his colleagues irradiated their samples with a high-energy photon beam. This beam of energy ejected some electrons from the sample, allowing them to collect information about the energy and momentum they exhibited while still in the sample.

"In this work, we studied three materials, palladium diselenides (PdSe_2), cuprate superconductors ($\text{Bi}_2\text{Sr}_2\text{CaCu}_2\text{O}_{8+\delta}$ or Bi-2212), and lead halide perovskites (CsPbBr_3)," Kim explained. "An important common property of these three materials is that they have certain crystal symmetries (multiple glide-mirror symmetries) that make all the electrons in the solid samples characterizable as one of four types."

Essentially, the researchers found that electrons in quantum systems with two pairs of sublattices can be characterized into four different categories. One of these types of electrons could be detected using angle-resolved photoemission spectroscopy, while the other three types were undetectable, as they were in dark states.

"It is just a possibility for now, but our result offers a new way to explain one of the long-standing issues in the study of high-temperature superconductivity, called the 'Fermi arc,'" Kim said. "Our nature is too complex to include everything in the theoretical model, and often you need to make a choice about what to include and what to exclude for approximation. Strictly speaking, there are sublattices in the unit structure of cuprate superconductors, but these sublattices have been overlooked so far."



Group members conducting angle-resolved photoemission spectroscopy experiments at synchrotron radiation Credit: Advanced Light Source, US, and Diamond Light Source, UK.

The recent work by this team demonstrates the existence of dark states in various quantum systems with two pairs of sublattices, including palladium diselenides, cuprate superconductors and lead halide perovskites. In the future, it could have important implications for the study of these materials, potentially broadening the understanding of their underlying physics.

"Our findings pose the question of whether it is really OK to leave out sublattices in the unit structure of cuprate superconductors when interpreting angle-resolved photoemission spectroscopy data collected from these materials," Kim added. "Our plan for future research is to dig into the Fermi arc problem of

cuprate superconductors in the same context but more deeply. We already have some promising results and are working on the next paper."

More information: Yoonah Chung et al, Dark states of electrons in a quantum system with two pairs of sublattices, *Nature Physics* (2024). [DOI: 10.1038/s41567-024-02586-x](https://doi.org/10.1038/s41567-024-02586-x)

Quantum Flatland Discovery Reveals New States of Matter

Scientists have made an exciting breakthrough by uncovering new states of matter using electrons. This discovery could change our understanding of the quantum world and open the door to new technologies.

This find is just the beginning of a deeper exploration into quantum physics and its many mysteries.

What Are These New States of Matter?

The newly discovered states of matter exist in a quantum world, where electrons behave in ways that defy our traditional understanding. These states don't fit into the usual categories like solids, liquids, or gases.

These exotic states could hold the key to future technologies, such as quantum computing.

How Electrons Hold the Secret

Electrons, the negatively charged particles that orbit an atom's nucleus, play a crucial role in these new states of matter. Under certain conditions, they exhibit collective behaviors that scientists have never seen before.

This collective behavior is what forms these mysterious new states, leading to groundbreaking discoveries in the field of quantum mechanics.

The Experiment That Led to the Discovery

Researchers conducted experiments that cooled materials down to near absolute zero and then applied strong magnetic fields. These extreme conditions revealed the new states of matter when the electrons began to behave in unexpected ways.

By manipulating these conditions, scientists were able to observe phenomena that had never been seen before.

Potential Applications in Technology

The discovery of these new states of matter could have a significant impact on future technologies. From more efficient energy storage to faster, more secure quantum computers, the possibilities are vast.

Understanding these new states may be the key to unlocking the full potential of quantum technology.

What This Means for Quantum Physics

This discovery adds a new layer to our understanding of quantum physics. By revealing these previously unknown states of matter, scientists are now able to delve deeper into the complex interactions of subatomic particles.

This deeper understanding could change the way we approach scientific problems at the quantum level.

A Step Toward Solving Quantum Mysteries

One of the biggest mysteries in quantum physics is how particles behave at incredibly small scales. The discovery of these new states of matter brings us closer to solving these mysteries and could lead to answers to fundamental questions about the universe.

Each discovery brings us closer to a full understanding of the strange quantum world.

Collaboration Across Disciplines

This breakthrough was made possible by collaboration between physicists, engineers, and material scientists. Combining expertise from various fields allowed the team to push the boundaries of what we know about matter.

Collaboration will continue to drive forward discoveries that could reshape entire industries.

Understanding the Bigger Picture

These findings aren't just about new states of matter; they're about gaining a more profound understanding of the universe itself. By piecing together the behavior of particles at the quantum level, scientists are unveiling the bigger picture of how our world functions at its most fundamental level.

These insights are essential for answering some of the most profound questions in science and philosophy.

The Beginning of a New Era in Science

The discovery of new states of matter is just the start. As scientists continue to push the limits of quantum research, we stand on the brink of a new era in science, with the potential to revolutionize technology, medicine, and our understanding of the universe itself.

The next breakthroughs in quantum physics could reshape our world in unimaginable ways, and this discovery is just the first step.

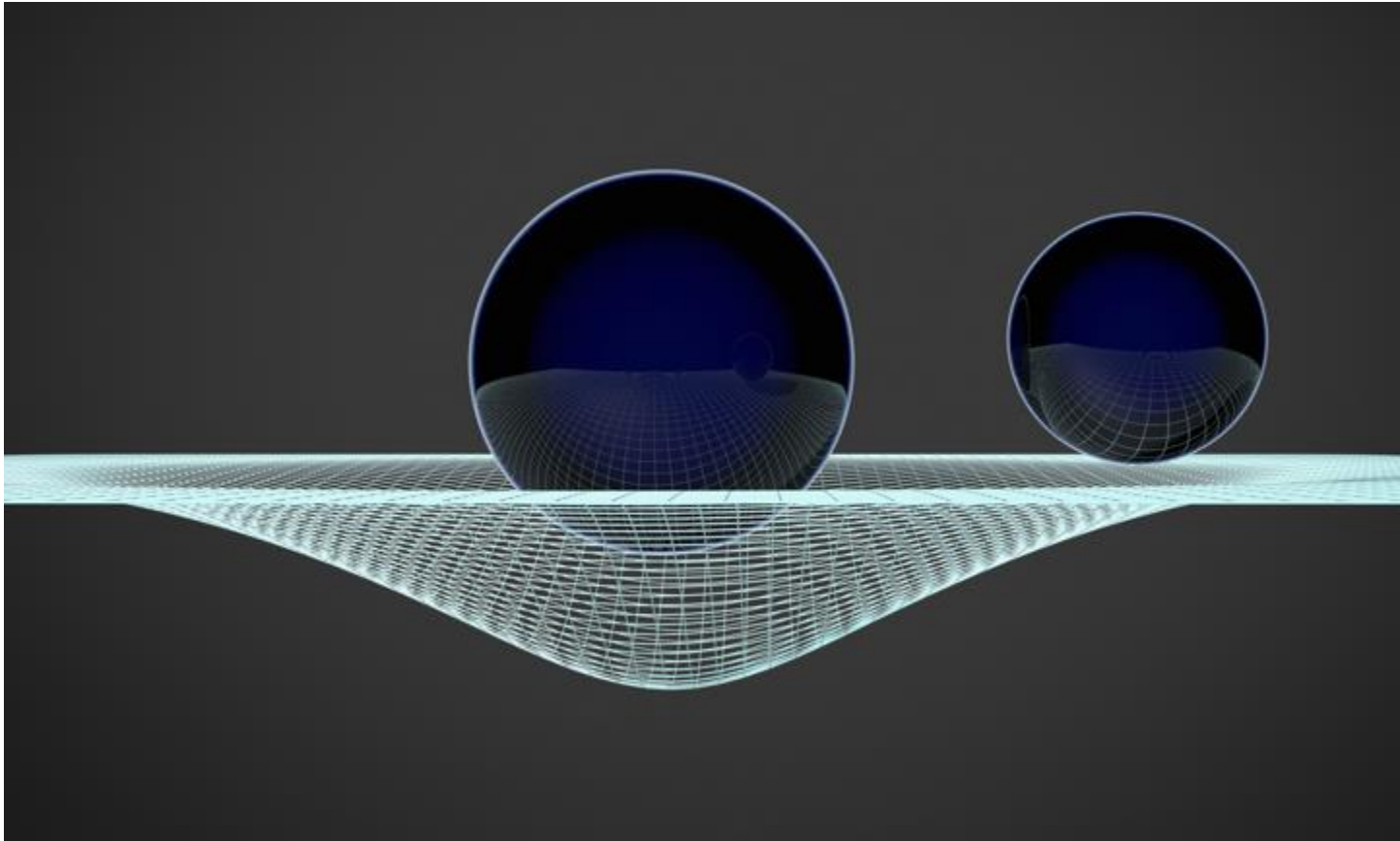

Magical equation unites quantum physics, Einstein's general relativity in a first

For the first time, a mathematical framework proves that Einstein's theory of general relativity, which explains the relationship between space, time, and gravity, is in alignment with quantum physics — the branch of science that describes the behavior of electrons, photons, and other fundamental particles.

"We proved that the Einstein field equation from general relativity is actually a relativistic quantum mechanical equation," the researchers note in their study.

In simple words, this new framework [connects the science](#) that governs the macroscopic world with that of the microscopic world.

Therefore, it has the potential to explain every physical phenomenon known to humanity ranging from the [mysterious dark matter](#) in space to the photons emitted by your phone's flashlight.

“To date, no globally accepted theory has been proposed to explain all physical observations,” the [researchers](#) added. They claim that their theory can challenge the foundations of physics and change our understanding of the universe.

The disconnect between relativity and the quantum world

Einstein’s [theory of general relativity](#) explains how gravity works. It says that massive objects like planets, stars, or galaxies bend the fabric of space and time around them, like a heavy ball on a trampoline. This bending creates what we feel as gravity.

So, instead of thinking of gravity as an invisible force pulling objects together, general relativity shows that objects move along curves in the warped space around them. The more massive the object, the more it bends space, and the stronger the gravitational effect.

Quantum physics, on the other side, is concerned with the study of the [unusual behavior](#) of the tiniest particles in the universe.

For instance, it investigates how particles such as electrons can exist in multiple states or locations at once (superposition) until we measure them. This type of strange behavior is not found in the objects we deal with regularly.

Until now, scientists have failed to reconcile general relativity and quantum physics because the two theories describe the universe in fundamentally different ways. When attempts were made to apply both theories together—such as in the case of black holes, they produced contradictory results, making it difficult to unify them into a single framework.

For example, general relativity predicts a black hole’s core is [infinitely dense](#), while quantum physics suggests such infinities can’t exist.

Bridging the gap between relativity and quantum physics

General relativity works well for large-scale objects, while quantum physics accurately describes microscopic phenomena, but what's the need to unite them? Well, there are two big reasons for that. First, combining these would provide a complete understanding of the universe across all scales.

This is important because many concepts such as black holes or the Big Bang are probably results of the conditions where both quantum physics and general relativity [played a role](#). Understanding them requires a theory that integrates both.

Second, one cannot fully understand the science behind quantum gravity, Hawking radiation, [string theory](#), and various other phenomena without connecting the dots between the theory of general relativity and quantum physics.

To link them, the researchers developed a mathematical framework that "Redefined the mass and charge of leptons (fundamental particles) in terms of the interactions between the energy of the field and the curvature of the spacetime."

"The obtained equation is covariant in space-time and invariant with respect to any Planck scale. Therefore, the constants of the universe can be reduced to only two quantities: Planck length and Planck time," the researchers note.

This equation mathematically proved that the [Einstein Field Equation](#) related to the theory of relativity is equal to the quantum equation. The study authors claim it can provide answers to various questions that have been a mystery.

For instance, it might explain why black holes don't collapse, what were the conditions during the Big Bang, and how space-time entanglement works.

Moreover, "In recent years, the James Webb Space Telescope (JWST) has observed several phenomena, including galaxies that had already existed 300 Myr after the big bang, which have never been thought to exist. Our proposed theory suitably explains this phenomenon," said the researchers.

The [study](#) is published in the journal *Astroparticle Physics*.

Gravity, the force that keeps our feet on the ground and the planets in orbit, is an integral part of our daily lives. Despite its ubiquity, the true [nature of gravity](#) remains a mystery. Scientists are still grappling with the question of whether gravity is fundamentally a geometrical phenomenon, as proposed by Einstein, or if it is governed by the laws of [quantum mechanics](#). In a study published in *Physical Review X*, researchers from Amsterdam and Ulm have proposed an innovative experiment that could shed light on this age-old question.

Ludovico Lami, a mathematical physicist at the [University of Amsterdam](#) and [QuSoft](#), and his colleagues have designed a new approach that circumvents the challenges faced by previous experimental proposals.

Quantum-gravity conundrum

The quest to unify quantum mechanics and gravitational physics is one of the most significant challenges in modern science. Progress in this field has been hindered by the inability to conduct experiments in regimes where both quantum and gravitational effects are relevant.

Related video: Gravitational Waves Create A 'Cosmic Symphony' That Scientists Are Tuning Into (Dailymotion)

As Nobel Prize laureate [Roger Penrose](#) once stated, we don't even know if a combined theory of gravity and quantum mechanics will require a "quantization of gravity" or a "granitization of quantum mechanics."

"The central question, initially posed by Richard Feynman in 1957, is to understand whether the gravitational field of a massive object can enter a so-

called [quantum superposition](#), where it would be in several states at the same time," explains Lami.

"Prior to our work, the main idea to decide this question experimentally was to look for gravitationally induced entanglement – a way in which distant but related masses could share [quantum information](#). The existence of such entanglement would falsify the hypothesis that the gravitational field is purely local and classical," he continued.

Overcoming the delocalisation dilemma

The primary obstacle in previous experimental proposals has been the creation of distant but related massive objects, known as delocalised states.

The heaviest object for which quantum delocalisation has been observed to date is a large molecule, which is significantly lighter than the smallest source mass whose gravitational field has been detected. This discrepancy has pushed the hope of an experimental realization decades into the future.

Designing a novel experiment to beat the odds

Lami and his colleagues have proposed a potential solution to this deadlock. Their experiment aims to reveal the [quantumness of gravity](#) without generating any entanglement.

"Our team designed and investigate a class of experiments involving a system of massive 'harmonic oscillators' – for example, torsion pendula, essentially like the one that Cavendish used in his famous 1797 experiment to measure the strength of the gravitational force," Lami explains.

"We establish mathematically rigorous bounds on certain experimental signals for quantumness that a local [classical gravity](#) should not be able to overcome. We have carefully analysed the experimental requirements needed to implement our proposal in an actual experiments, and find that even though some degree of

technological progress is still needed, such experiments could really be within reach soon."

Power of entanglement theory

Surprisingly, the researchers still rely on the mathematical machinery of entanglement theory in quantum information science to analyze their experiment, despite the absence of physical entanglement.

Lami clarifies, "The reason is that, although [entanglement](#) is not physically there, it is still there in spirit -- in a precise mathematical sense. It is enough that entanglement could have been generated."

New era of quantum gravity research

In summary, the study by Lami and his colleagues from Amsterdam and Ulm opens a new chapter in the quest to unravel the quantum nature of gravity.

Their innovative experimental proposal, which relies on the mathematical framework of entanglement theory without requiring physical entanglement, brings us closer to answering the fundamental question posed by Richard Feynman over six decades ago.

As technological progress continues to advance, the realization of this experiment becomes increasingly feasible, promising to shed light on one of the most profound mysteries in modern physics.

The implications of this research extend far beyond the realm of theoretical physics, as a deeper understanding of the quantum-gravity relationship could revolutionize our perception of the universe and our place within it.

The full study was published in the journal [Physical Review X](#).

A team led by Robert Keil and Tommaso Faleo from the Department of Experimental Physics has investigated the relationship between entanglement and interference in quantum systems of more than two particles in the laboratory.

Together with researchers from the University of Freiburg, Germany, and Heriot-Watt University, U.K., they gained new insights into the behavior of multi-particle quantum systems. In the interview, Tommaso Faleo explains how interference patterns of more than two photons can be interpreted.

Your group at the Department of Experimental Physics has just [published](#) a new research paper in the *Science Advances*, in which you link the fascinating quantum phenomena of entanglement and interference. What was the aim of your work?

Faleo: The aim of the research was to explore and better understand the relationship between entanglement and interference in systems involving more than two particles. The interference dynamics in such multi-particle systems are particularly complex, and the presence of entanglement introduces an additional layer of complexity.

We focused on examining how interference patterns emerge when some of the particles are in an entangled state and what their specific characteristics are.

Could you briefly explain what entanglement and interference stand for?

Entanglement is a purely quantum phenomenon in which the properties of two or more particles become interlinked, such that they can no longer be described as independent entities, no matter how far apart they are. This fundamental aspect of quantum mechanics puzzled early researchers in quantum physics and now underlies several applications in quantum technologies.

In classical physics, waves can give rise to interference patterns when their amplitudes add up constructively (enhancing each other) or destructively (canceling each other out). This is analogous to interference in quantum mechanics, where the probability amplitudes of different outcomes can combine to increase or decrease the likelihood of certain events.

Two-particle interference adds another layer to this quantum interference and arises from the indistinguishability of identical particles. First demonstrated by Hong, Ou, and Mandel in 1987, this effect is now the key to many optical quantum technologies. Multi-photon interference is the extension of this effect to more than two particles.

You investigated interference patterns of more than two photons. What did you see in the experiment?

When analyzing systems with more than two particles, the interference patterns become significantly more complex than in the basic Hong-Ou-Mandel experiment. We observed that these patterns are influenced not only by the quantum states of the individual particles but also by the entanglement shared among some of them.

In our interference scenario, the particles' entanglement bridges the spatial gap between separate interferometers, introducing an interference pattern that depends on the overall quantum state of all the particles involved, and is inaccessible when one or more particles are excluded from the dynamics.

These results provide new insights into the behavior of multi-particle quantum systems and how their states influence interference patterns.

What are the implications of the findings for further research?

The results showcase a new type of collective interference effect that combines entanglement with the highly complex dynamics of multi-particle systems. This contributes to our understanding of how quantum mechanics works in many-body systems, potentially leading to both new theoretical insights and developments in quantum technologies.

More information: Tommaso Faleo et al, Entanglement-induced collective many-body interference, *Science Advances* (2024). DOI: [10.1126/sciadv.adp9030](https://doi.org/10.1126/sciadv.adp9030)

Provided by University of Innsbruck

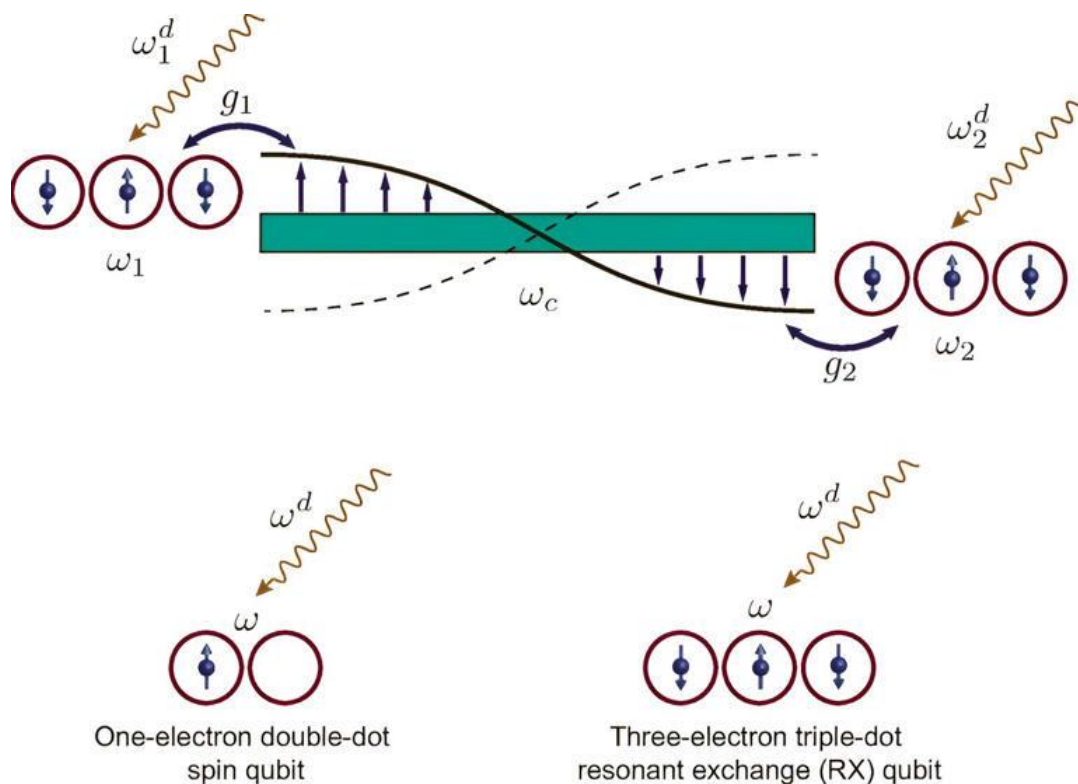

Schematic illustration of a system for cavity-mediated coupling of two parametrically driven quantum dot spin qubits via sidebands. Credit: PRX Quantum (2024). DOI: 10.1103/PRXQuantum.5.020339

The operation of a quantum computer relies on encoding and processing information in the form of quantum bits—defined by two states of quantum systems such as electrons and photons. Unlike binary bits used in classical computers, quantum bits can exist in a combination of zero and one simultaneously—in principle allowing them to perform certain calculations exponentially faster than today's largest supercomputers.

To reach their full potential, quantum computers need millions of quantum bits, or qubits. But a challenge arises as quantum information processing systems are scaled to many qubits. Highly complex electronics are needed to control even a few qubits and scaling that complex circuitry represents a major hurdle.

In recent theoretical research, a team of physicists, led by University of Rhode Island professor Vanita Srinivasa, envisions a modular system for scaling quantum processors with a flexible way of linking qubits over long distances to enable them to work in concert to perform quantum operations. The ability to carry out such correlated or "entangling" operations between linked qubits is the basis of the enhanced power quantum computing holds compared with current computers.

A new [paper](#) on their research, co-authored by Srinivasa, Jacob M. Taylor of the University of Maryland and the National Institute of Standards and Technology, and Jason R. Petta of the University of California, Los Angeles, was recently published in the journal *PRX Quantum*.

"Each qubit in a quantum computer operates at a specific frequency. Realizing the capabilities unique to a quantum computer relies on being able to control each qubit individually via a distinct frequency, as well as to link pairs of qubits by matching their frequencies," said Srinivasa, director of URI's Quantum Information Science program and an assistant professor of physics.

"As a quantum processor is scaled to larger numbers of qubits, being able to simultaneously achieve both of these operations for every qubit becomes very challenging. In our work, we describe how applying oscillating voltages effectively generates extra frequencies for each qubit in order to link multiple qubits without having to match all of their original frequencies. This allows qubits to be linked

while simultaneously allowing each qubit to retain a distinct frequency for individual control."

Using semiconductors to build quantum processors is in principle very promising for scaling qubits to large numbers. The advanced semiconductor technology that exists today forms the basis for fabricating chips with billions of tiny transistors and can be harnessed to make qubits that are compact in size, Srinivasa said. Additionally, storing qubits in an internal property of electrons and other semiconductor particles known as spin provides enhanced protection from the quantum information loss inherent in every quantum computing platform.

However, scaling up a quantum processor by simply adding more and more spin qubits and their associated control circuitry to a single array of qubits is very challenging in practice. The theoretical work by Srinivasa and her colleagues addresses this problem by providing a step-by-step guide that shows multiple ways to entangle spin qubits over long distances with flexibility in matching their frequencies.

The resulting flexibility opens a pathway to semiconductor-based modular quantum information processing, which represents an alternative approach for building many-qubit systems using small arrays of qubits—modules—that can already be made today, and connecting them with robust, long-range entangling links.

"This approach to scaling is like building a larger system using fixed-size LEGO blocks, which are like individual modules, and connecting them using longer pieces that are strong enough to maintain the connection between the blocks for a sufficient time before external influences break the links," Srinivasa said.

"Provided fast and reliable long-distance links between qubits are available, such a modular approach allows scaling while providing more space for the spin qubit control circuitry." Fully modular semiconductor-based quantum processors have yet to be demonstrated.

While there are many types of qubits and a corresponding variety of ways for them to interact, the researchers chose to study quantum dot-based spin qubits that interact through microwave photons in a superconducting cavity. Quantum dots are atom-like structures created to confine electrons—and other particles used to define qubits—to small spaces within semiconductors and control them

individually by applying voltages. Likewise, superconducting cavities are fabricated structures that confine photons but are much larger than quantum dots, with a size set by the wavelength of microwaves.

Recent experiments have demonstrated long-distance links between quantum dot spin qubits using microwave cavity photons. (The first demonstration for two spin qubits in silicon was achieved by co-author Jason Petta's experimental research group.)

However, tuning all of the qubit and photon frequencies so they precisely match and can exchange energy—a condition called resonance—to establish a link has been a problem even at just the two-qubit level, the paper says. To address this problem, the researchers present a highly tunable approach for linking qubits using microwave photons that does not rely on simultaneous resonance among all original qubit and cavity frequencies.

In their paper, the researchers provide comprehensive guidelines for tailored long-distance entangling links that allow flexibility by making multiple frequencies available for each qubit to become linked with microwave cavity photons of a given frequency, "like multiple keys that can fit a given lock," Srinivasa said.

Extra frequencies can be generated by applying an oscillating voltage to each spin qubit that moves the spins back and forth in the quantum dots. If this back-and-forth motion is fast enough, two sideband frequencies—one higher and one lower in frequency than the original qubit frequency—are created for each qubit in addition to their characteristic frequency.

The addition of the sideband frequencies results in three ways to tune each qubit into resonance with microwave cavity photons, and consequently nine different conditions under which two qubits can be linked.

This flexibility in resonance conditions would make it much easier to add qubits to a system because they do not all need to be tuned to the same frequency. Furthermore, the nine ways for two qubits to be linked enable several different types of entangling operations to be selected simply by setting the oscillating voltages appropriately, without having to modify the structure of either the quantum dots or the cavity photons.

The versatility in types of entangling links enables an expanded set of elementary quantum operations with which to perform calculations. Finally, the researchers show that their proposed entangling method is less sensitive to leakage of photons out of the cavity than previous approaches, allowing for more robust long-distance links between spin qubits.

"The combination of flexibility in matching frequencies, versatility in tailoring the types of quantum entangling operations between qubits, and reduced sensitivity to cavity photon leakage renders our proposed sideband frequency-based approach promising for realizing a modular quantum processor using semiconductor qubits," Srinivasa said.

"I am excited for the next step, which is to apply these ideas to real quantum devices in the laboratory and find out what we need to do to make the approach work in practice."

More information: V. Srinivasa et al, Cavity-Mediated Entanglement of Parametrically Driven Spin Qubits via Sidebands, *PRX Quantum* (2024). [DOI: 10.1103/PRXQuantum.5.020339](https://doi.org/10.1103/PRXQuantum.5.020339)

Provided by University of Rhode Island

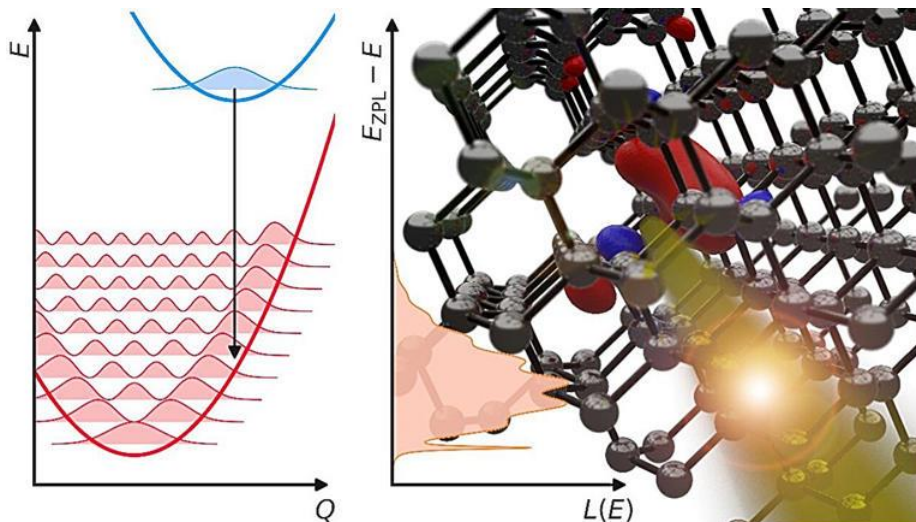

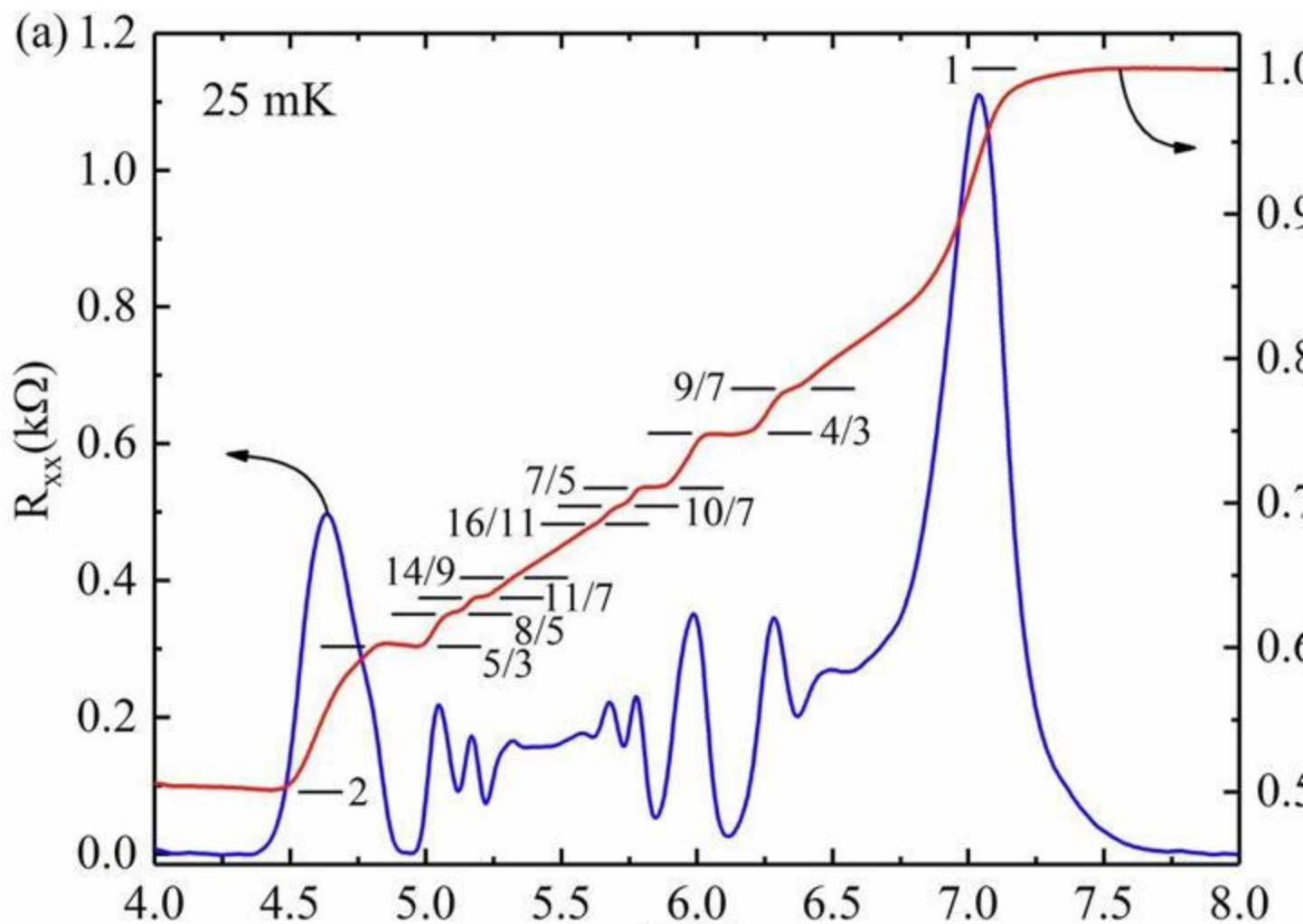

Transport characteristics of a GaAs/AlGaAs heterostructure Hall bar device at $T = 25$ mK. a The diagonal (R_{xx}) and off-diagonal Hall (R_{xy}) resistances are exhibited between $4 \leq B \leq 8$ Tesla, corresponding to the filling factor range $2 \leq \nu \leq 1$, to highlight observable FQHE. b R_{xx} and R_{xy} are exhibited for the full range $0 \leq B \leq 8.5$ Tesla. c R_{xy} are exhibited for the IQHE regime between $0 \leq B \leq 4.5$ Tesla, for different DC bias currents (IDC) between $0 \leq IDC \leq 1 \mu\text{A}$ in steps of $\Delta IDC = 0.25 \mu\text{A}$. The traces, which indicate that IDC does not modify observable IQHE (marked by horizontal lines), have been offset along the abscissa by 1 Tesla for the sake of clarity. Credit: Communications Physics (2024). DOI: 10.1038/s42005-024-01759-7

Imagine a two-dimensional flatland, instead of our three-dimensional world, where the rules of physics are turned on their head and particles like electrons defy expectations to reveal new secrets. That's exactly what a team of researchers, including Georgia State University Professor of Physics Ramesh G. Mani and recent Ph.D. graduate U. Kushan Wijewardena, has been studying at Georgia State's laboratories.

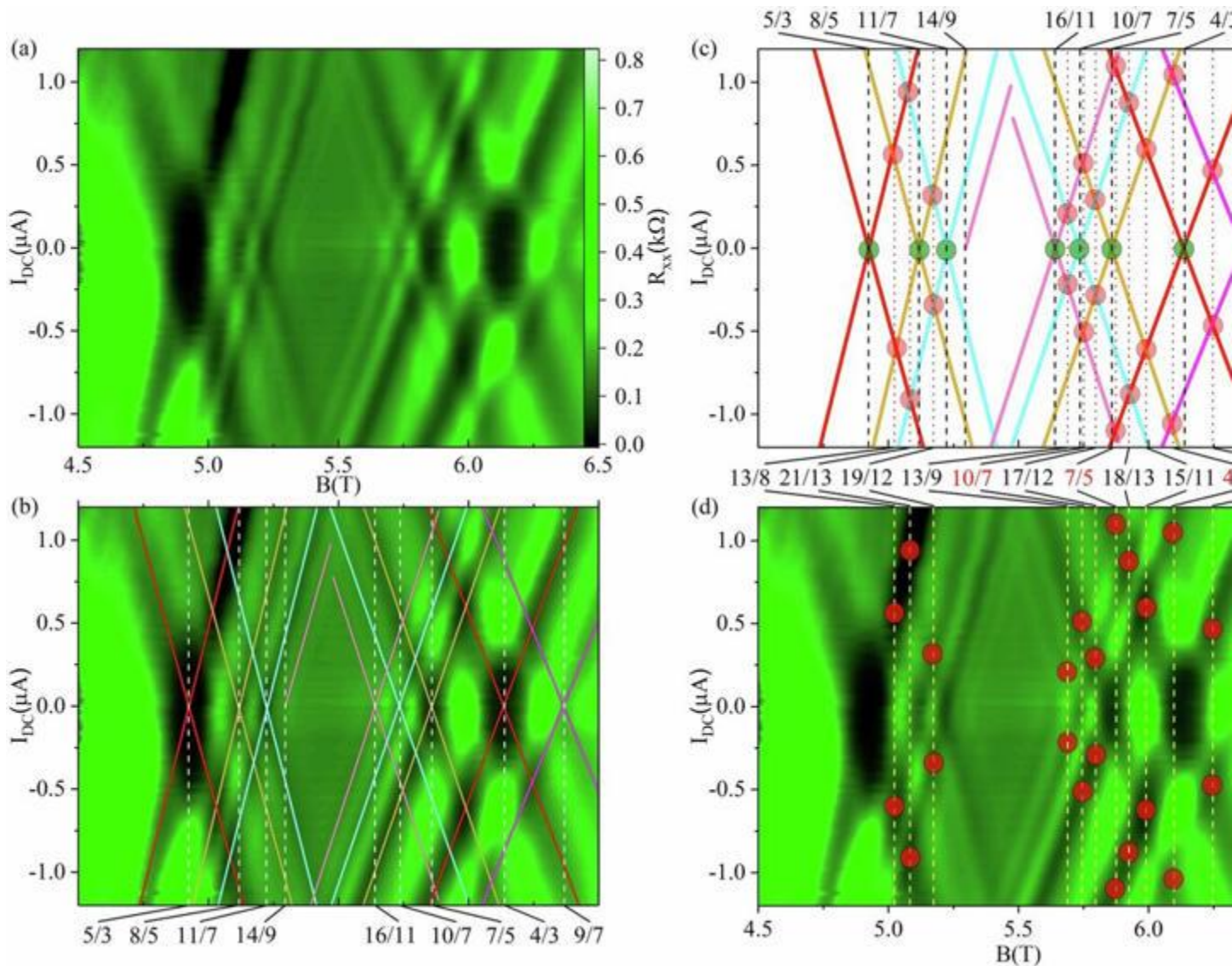

Splitting of equilibrium FQHE states under current bias. Credit: *Communications Physics* (2024). DOI: 10.1038/s42005-024-01759-7

Their studies have resulted in a discovery recently [published](#) in the journal *Communications Physics*. The team has investigated the enigmatic world of fractional quantum Hall effects (FQHE), uncovering novel, unexpected phenomena when these systems are probed in new ways and pushed beyond their usual boundaries.

"Research on fractional quantum Hall effects has been a major focus of modern condensed matter physics for decades because particles in flatland can have multiple personalities and can exhibit a context-dependent personality on demand," Mani said. "Our latest findings push the boundaries of this field, offering new insights into these complex systems."

The quantum Hall effect has been a vibrant and pivotal area in condensed matter physics since 1980, when Klaus von Klitzing reported his discovery that a simple electrical measurement could give very accurate values for some fundamental constants that determine the behavior of our universe. This discovery won him a Nobel Prize in 1985.

In 1998, a Nobel Prize was awarded for the discovery and understanding of the fractional quantum Hall effect, which suggested that flatland particles could have fractional charges. The journey continued with the discovery of graphene, a material that showed the possibility of massless electrons in flatland, leading to yet another Nobel Prize in 2010.

Finally, theories about new phases of matter, related to the quantum Hall effect, were recognized with a Nobel Prize in 2016.

Condensed matter physics gave rise to discoveries that made modern electronics like cellphones, computers, GPS, LED lighting, solar cells and even self-driving cars possible. Flatland science and flatland materials are now being studied in condensed matter physics with the aim of realizing more energy-efficient, flexible, faster and lighter-weight future electronics, including novel sensors, higher efficiency solar cells, quantum computers and topological quantum computers.

In a series of experiments in extremely cold conditions, close to -459°F (-273°C), and under a magnetic field nearly 100,000 times stronger than that of Earth, Mani, Wijewardena and colleagues went to work. They applied a supplementary current to high-mobility semiconductor devices made from a sandwich structure of gallium arsenide (GaAs) and aluminum gallium arsenide (AlGaAs) materials, which helps to realize electrons in a flatland.

They observed all the FQHE states splitting unexpectedly, followed by crossings of split branches, which allowed them to explore the new non-equilibrium states of these quantum systems and reveal entirely new states of matter.

The study highlights the crucial role of high-quality crystals, produced at the Swiss Federal Institute of Technology Zurich by Professor Werner Wegscheider and Dr. Christian Reichl, in the success of this research.

"Think of the traditional study of fractional quantum Hall effects as exploring the ground floor of a building," Mani said. "Our study is about looking for and discovering the upper floors—those exciting, unexplored levels—and finding out what they look like. Surprisingly, with a simple technique, we were able to access these upper floors and uncover complex signatures of the excited states."

Wijewardena, who earned his Ph.D. in physics from Georgia State last year and is now a faculty member at Georgia College and State University in Milledgeville, expressed his excitement about their work.

"We have been working on these phenomena for many years, but this is the first time we've reported these experimental findings on achieving excited states of fractional quantum Hall states induced by applying a direct current bias," Wijewardena said. "The results are fascinating, and it took quite a while for us to have a feasible explanation for our observations."

The study not only challenges existing theories but also suggests a hybrid origin for the observed non-equilibrium excited-state FQHEs. This innovative approach and the unexpected results highlight the potential for new discoveries in the field of condensed matter physics, inspiring future research and technological advancements.

The implications of the team's findings stretch far beyond the lab, hinting at potential insights for quantum computing and materials science. By exploring these uncharted territories, these researchers are laying the groundwork—and training new generations of students—for future technologies that could revolutionize everything from data processing to energy efficiency, while powering up the high-tech economy.

Mani, Wijewardena and their team are now extending their studies to even more extreme conditions, exploring new methods to measure challenging flatland parameters. As they push forward, they anticipate uncovering further nuances in these quantum systems, contributing valuable insights to the field. With each experiment, the team moves closer to understanding the complex behaviors at play, staying open to the possibility of new discoveries along the way.

More information: U. Kushan Wijewardena et al, Non-equilibrium excited-state fractionally quantized Hall effects observed via current bias spectroscopy, *Communications Physics* (2024). [DOI: 10.1038/s42005-024-01759-7](https://doi.org/10.1038/s42005-024-01759-7)

Quantum simulation enables scientists to simulate and study complex systems that are challenging or even impossible using classical computers across various fields, including financial modeling, cybersecurity, pharmaceutical discoveries, AI and machine learning. For instance, exploring molecular vibronic spectra is critical in understanding the molecular properties in molecular design and analysis.

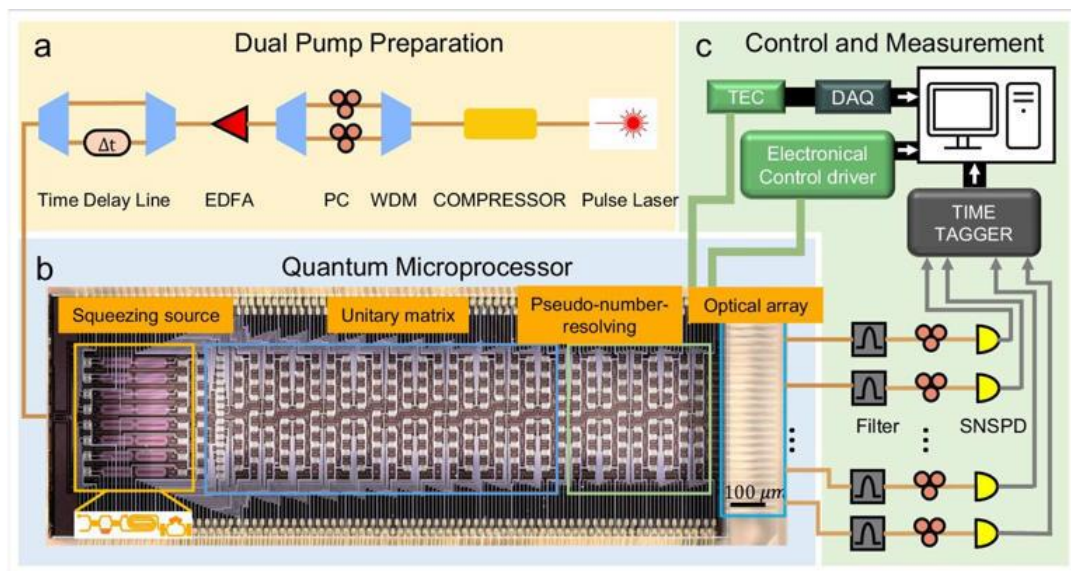

Schematic of a quantum microprocessor chip and experimental setup. Credit: Nature Communications (2024). DOI: 10.1038/s41467-024-50060-2

However, it remains a long-standing computationally difficult problem that cannot be efficiently solved using traditional super-computers. Researchers are diligently working on quantum computers and algorithms to simulate molecular vibronic spectra. However, they are limited to simple molecule structures, as they struggle with low accuracy and inherent noise.

Engineering researchers at The Hong Kong Polytechnic University (PolyU) have successfully developed a quantum microprocessor chip for molecular spectroscopy simulation of actual large-structured and complex molecules, a world-first achievement.

Capturing these quantum effects accurately requires meticulously developed simulations that account for quantum superposition and entanglement, which are computationally intensive to model classically.

The research is published in *Nature Communications*, in a paper titled "[Large-scale photonic network with squeezed vacuum states for molecular vibronic spectroscopy.](#)"

This cutting-edge technology paves the way to solving complicated quantum chemistry problems, including quantum computational applications which are beyond the capabilities of classical computers.

The research team is led by Professor Liu Ai-Qun, a Chair Professor of Quantum Engineering and Science and Director of the Institute for Quantum Technology (IQT), a Global STEM Scholar and Fellow of Singapore Academy of Engineering, together with the main project driver, Dr. Zhu Hui Hui, Postdoctoral Research Fellow of the Department of Electrical and Electronic Engineering and the first author of the research paper.

Nanyang Technological University, City University of Hong Kong, Beijing Institute of Technology, Southern University of Science and Technology, the Institute of Microelectronics and Chalmers University of Technology in Sweden.

Dr. Zhu's team have experimentally demonstrated a large-scale quantum microprocessor chip and introduced a nontrivial theoretical model employing a linear photonic network and squeezed vacuum quantum light sources to simulate molecular vibronic spectra. The 16-qubit quantum microprocessor chip is fabricated and integrated into a single chip.

A complete system has been developed, including the hardware integration of optical–electrical–thermal packaging for the quantum photonic microprocessor chip and electrical control module, software development for device drivers, user interface and underlying quantum algorithms which are fully programmable. The quantum computer system developed provides a fundamental building block for further applications.

The quantum microprocessor can be applied to solving complex tasks, such as simulating large protein structures or optimizing molecular reactions with significantly improved speed and accuracy.

Dr. Zhu said, "Our approach could yield an early class of practical molecular simulations that operate beyond classical limits and hold promise for achieving quantum speed-ups in relevant quantum chemistry applications."

Quantum technologies are crucial in scientific fields, including material science, chemistry and condensed matter physics. As an attractive hardware platform, the

quantum microprocessor chips present a promising technological alternative for quantum information processing.

The research findings and the resulting integrated quantum microprocessor chip developed open significant new avenues for numerous practical applications. These applications include solving molecular docking problems and leveraging quantum machine learning techniques like graph classification.

Professor Liu said, "Our research is inspired by the potential real-world impact of quantum simulation technologies. In the next phase of our work, we aim to scale up the microprocessor and tackle more intricate applications that could benefit society and industry."

The team has successfully tackled the highly challenging task of molecular spectroscopy simulation using a quantum computing microprocessor. Their research marks a significant advancement in quantum technology and its potential quantum computing applications.

More information: Hui Hui Zhu et al, Large-scale photonic network with squeezed vacuum states for molecular vibronic spectroscopy, *Nature Communications* (2024). [DOI: 10.1038/s41467-024-50060-2](https://doi.org/10.1038/s41467-024-50060-2)

Provided by Hong Kong Polytechnic University

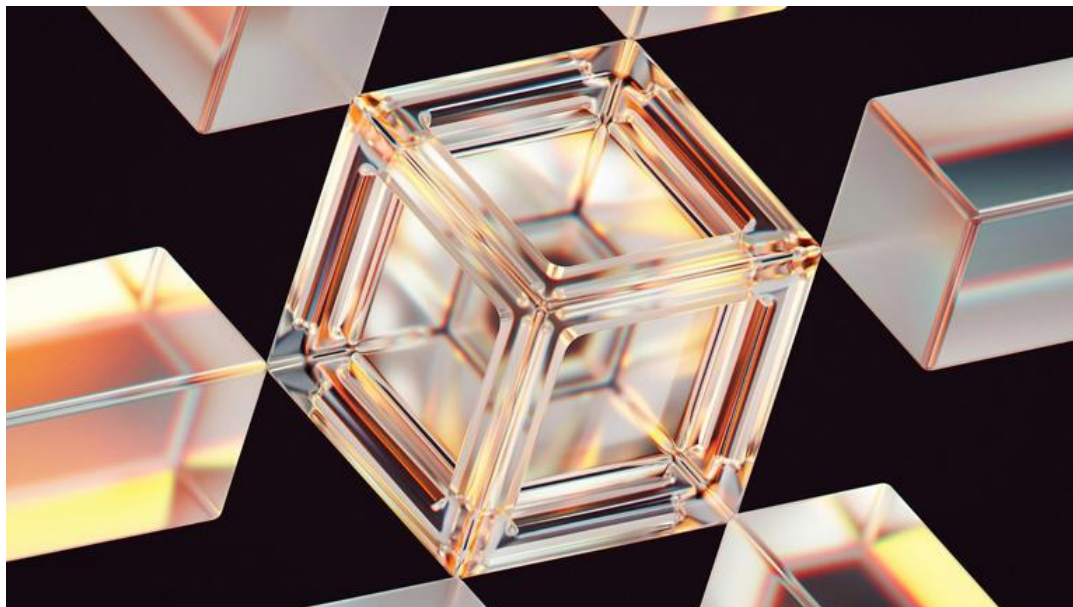

'Modular' approach can help researchers connect, control millions of qubits

The creation of powerful quantum computers requires quantum processors with millions of qubits. However, currently, the most advanced quantum processor is composed of only 1000 qubits.

This means that we're far behind in achieving the true potential of quantum computers, and the challenge lies in controlling and connecting qubits.

Each qubit in a quantum computer works at a specific frequency. To harness the full power of a quantum system, each qubit should be controlled individually by tuning its frequency. Plus, to connect qubits, it is important to match their frequencies.

"As a quantum processor is scaled to larger numbers of qubits, being able to simultaneously achieve both of these operations for every qubit becomes very challenging," Vanita Srinivasa, an assistant professor of Physics at the University of Rhode Island (URI), [said](#).

However, Srinivasa and her team at URI have figured out a solution to this problem. In their new study, they propose a modular system that can overcome the challenges mentioned above and connect [qubits over long distances](#).

Using extra frequencies to link qubits

To make a powerful quantum processor, its qubits must achieve [quantum entanglement](#). This means that millions of qubits must be linked in a way that the state of one qubit instantly affects the state of the other, no matter how far apart they are.

This will allow qubits to share information in a unique way, enabling [quantum computers](#) to perform multiple calculations simultaneously and solve complex problems a thousand times faster than classical computers.

However, entangling qubits requires controlling and connecting qubits over long distances. The proposed modular system suggests that applying oscillating voltages introduces additional frequencies for each qubit.

This means that apart from their original frequency, each qubit now has an extra frequency.

According to the researchers, while the original frequency can be used to control the qubits individually, their extra frequency can be matched to connect them.

“We describe how applying oscillating voltages effectively generates extra frequencies for each qubit in order to link multiple qubits without having to match all of their original frequencies. This allows qubits to be linked while simultaneously allowing each qubit to retain a distinct frequency for individual control,” the study authors note.

A practical way to connect qubits

There’s one more problem. Qubits can’t be connected directly because they need a mediator to help match their frequencies and carry information between them, according to the researchers.

For this purpose, the study authors used special microwave cavity photons. So when qubit frequencies are close but not identical, these photos help adjust the frequencies and facilitate communication between qubits.

Our study “provides comprehensive guidelines for tailored long-distance entangling links that allow flexibility by making multiple frequencies available for each qubit to become linked with microwave cavity photons of a given frequency, like multiple keys that can fit a given lock,” said Srinivasa.

This modular approach provides a practical way for a quantum system to easily adjust to [match different qubit](#) frequencies. Besides, it is flexible enough to support various types of entanglement between qubits and is less prone to issues with photon leakage.

"I am excited for the next step, which is to apply these ideas to real quantum devices in the laboratory and find out what we need to do to make the approach work in practice," Srinivasa added.

The [study](#) is published in the journal *PRX Quantum*.

Physics is a continually advancing field, with new discoveries occurring daily.

Newton's theory of gravity and Galileo's description of planetary motion are key components of classical physics.

Isaac Newton, Gottfried Leibniz, and Galileo Galilei established the foundations of classical mechanics. Two centuries later, James Clerk Maxwell formulated a theory of electromagnetism, explaining the behavior of electricity and magnetism.

These theories are considered classical, indicating they do not account for phenomena under extreme conditions, such as at the quantum level or on the scale of galaxies and the universe.

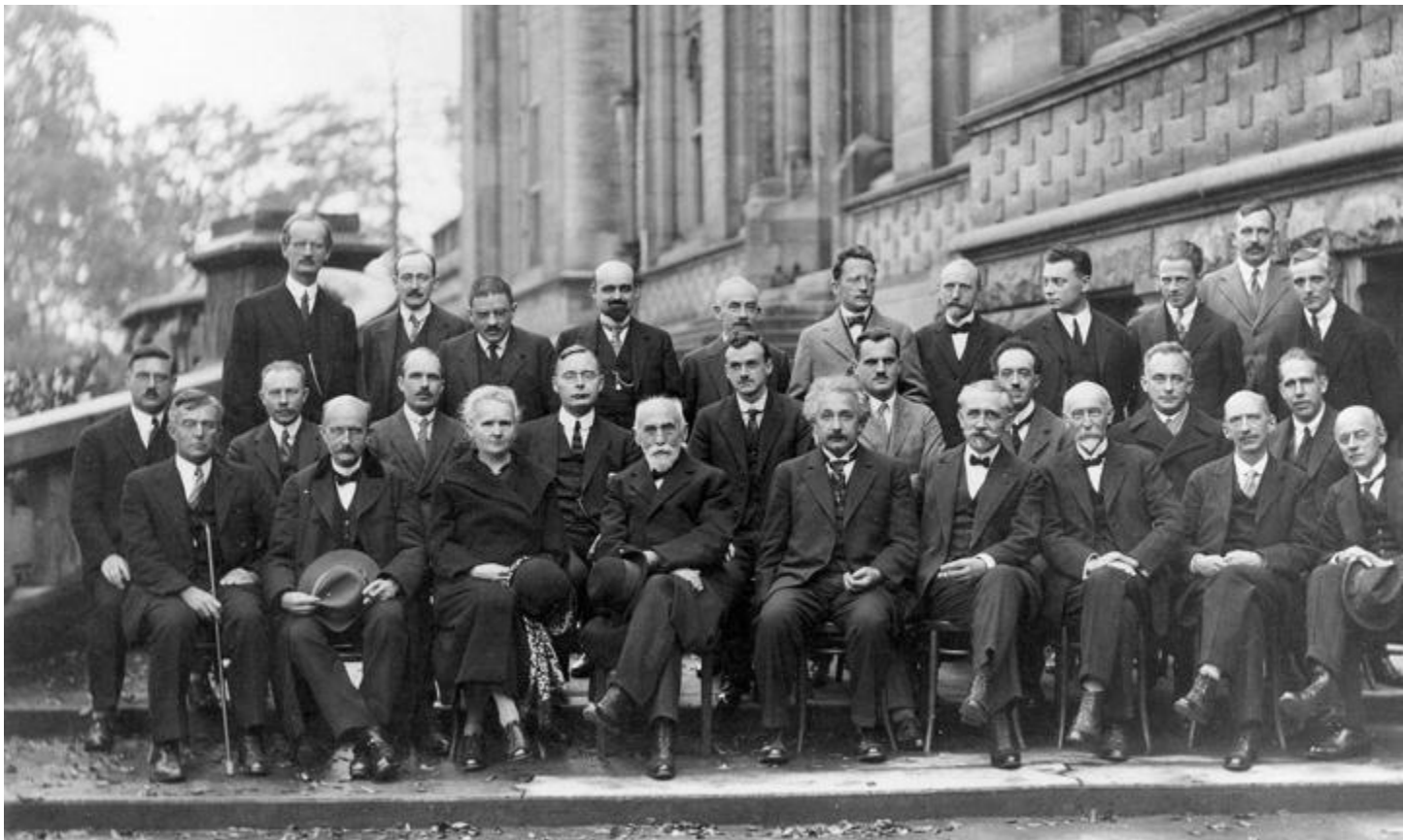

Some of the pioneers of modern physics, including Einstein, at the Solvay Conference on Quantum Mechanics in 1927. Credit: Benjamin Couprie, Institut International de Physique Solvay, Brussels, Belgium .© Provided by Interesting Engineering

Enter modern physics. A branch of physics that involves more radical thinking to explain things at microscopic and macroscopic levels. This way of approaching physical theories started in the late 19th century with pioneers like [Albert Einstein](#), Paul Dirac, and Neils Bohr.

Modern physics stands on two pillars: Einstein's theory of relativity and the [Standard Model](#) of particle physics. The theory of relativity encompasses the gravitational force, one of the four fundamental forces in the Universe.

Conversely, the Standard Model encompasses the other three forces—nuclear weak and strong and electromagnetic forces.

In this two-part article, we break down these pillars of modern physics and gain a deeper understanding of why they are so integral in science today.

In part one, we will focus on the theories of relativity.

Shortcomings of classical physics

While classical physics successfully explains many day-to-day phenomena—before the development of modern physics—there were several instances where it failed.

One of them was the motion of Mercury around the Sun. Astronomers had observed a shift (or precession) in Mercury's orbit around the Sun over time. Newton's gravitation could not explain this observed shift.

Classical physics also couldn't explain why the speed of light was always constant.

At that time, the prevailing belief was that the universe was filled with ether, a substance through which light waves propagated. This was based on the

Two scientists (Albert A. Michelson and Edward W. Morley) undertook the [Michelson-Morley experiment](#) in 1887 to put this hypothesis to the test. Their

experiment showed that the speed of light remained constant, contrary to what would happen if the Earth moved through ether.

Einstein's propositions

Einstein's motivation to understand the nature of light began when he was just 16 years old. His theory of special relativity stemmed from his desire to understand the nature of light and what would happen to objects moving near or at the speed of light. This led him to develop the photoelectric effect, which won him the Nobel Prize.

Special relativity

In 1905, Einstein published the first of his many papers addressing the shortcomings of classical physics about light and spacetime. This was his theory of [special relativity](#).

Einstein introduced two main postulates in his special relativity theory.

1. The first postulate is about the laws of physics in inertial frames of reference. According to Einstein, the laws of physics do not change, no matter which inertial frame you are in. Galileo Galilei originally presented this postulate.

An object in an inertial frame remains in motion or at rest until an external force acts upon it.

2. The second postulate concerns the speed of light. Einstein showed that the speed of light is the same in a vacuum, despite the motion of the light itself or the observer. This value (c) is equal to 299,792,458 meters per second.

These postulates have several implications for observed phenomena.

Time dilation

One of the most fascinating implications of these postulates is that [time passes](#) more slowly for objects traveling near the speed of light than when the object would be at rest.

Several [experiments](#) involving muons (a type of subatomic particle) and high-precision atomic clocks have confirmed this.

In other words, a person traveling in a spaceship near the speed of light would age slower than if they were on Earth.

Relativity of simultaneity

According to Einstein's theory, simultaneous events in one reference frame may not be simultaneous in another, which is in motion relative to the first.

For example, a person standing on a train platform might see two [lightning strikes](#) simultaneously, but a passenger on a moving train might see one strike before the other.

This is because it takes time for the light to travel. So when the train is in motion, the light will have to cover that extra distance to reach the passenger on the train.

Mass-energy equivalence

$E = mc^2$ is possibly the most famous equation in [physics](#) and probably the work Einstein is best known for.

According to this equation, mass and energy are interchangeable, meaning they are different forms of the same thing. However, the conversion factor is the square of the speed of light, which is a huge number.

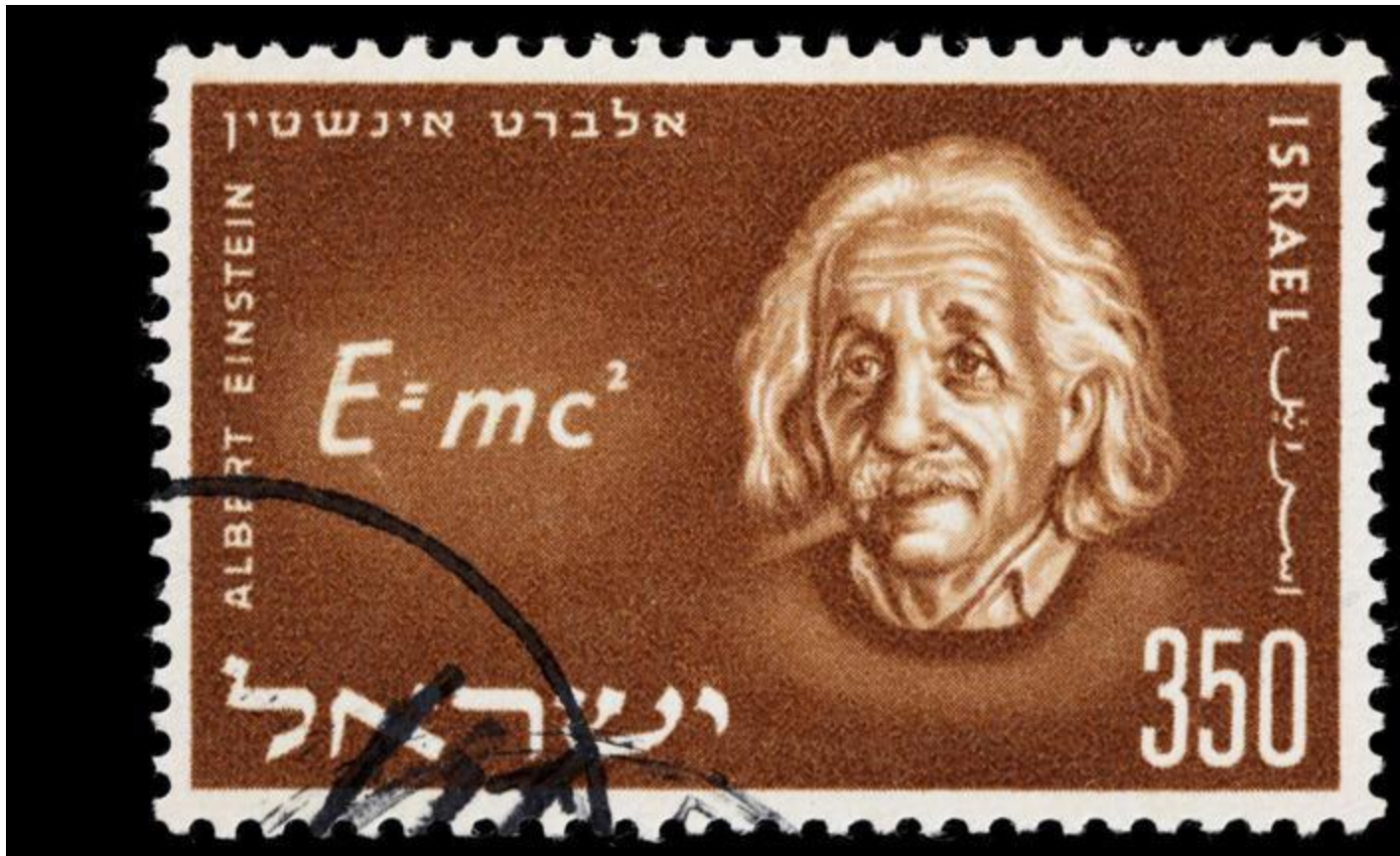

A postal stamp from 1956 featuring Einstein and his mass-energy equation. Credit: PictureLake/iStock .© Provided by Interesting Engineering

This means that it is very hard to change one to another. According to [PBS Nova](#), if one atom in a paper clip were converted to pure energy, we would have the same amount of energy that 18 kilotons of TNT would produce!

This equation is how atomic bombs and nuclear fission reactors work.

Minkowski's contributions

In 1908, before Einstein published his work on general relativity, mathematician Hermann Minkowski introduced the concept of four-dimensional space, called Minkowski spacetime.

This [four-dimensional space](#) consists of the three spatial dimensions that we are familiar with and added time to it.

Minkowski's work gave us a geometric understanding of why different observers can disagree on the simultaneity of events, and how time can appear dilated depending on relative velocities.

It also laid down the mathematical foundation upon which Einstein built his theory of general relativity.

General relativity

In 1915, Einstein published his paper on [general relativity](#), a theory of gravitation. While Newton's gravity explained everyday phenomena, it did not explain the nature of gravity itself.

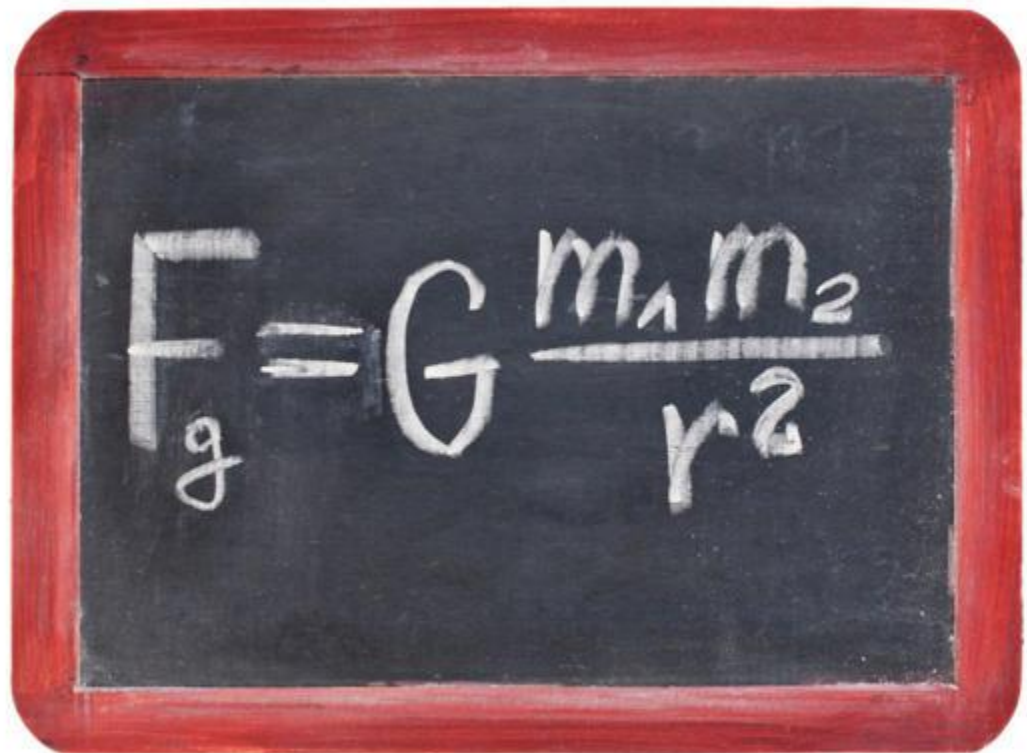
$$F_g = G \frac{m_1 m_2}{r^2}$$

Newton's law of gravitational describing the gravitational forces between two objects. Credit: marekuliasz/iStock
© Provided by Interesting Engineering

Einstein knew that his theory of special relativity was partial. It couldn't be applied to accelerating (or non-inertial) objects or gravity.

Equivalence principle

This led Einstein to formulate the Equivalence Principle, a cornerstone of general relativity. According to the [equivalence principle](#), the effects of gravity are *indistinguishable* from the effects of acceleration for an observer in a small region of spacetime.

So, if you were in a closed room on Earth, the force you would feel would be the same if the room were accelerating upwards in space at 9.8 meters per second squared.

This led Einstein to explore the idea [that gravity](#) may not be a force in the traditional sense of pulling or pushing of objects and might be a manifestation of spacetime.

Curved spacetime

From 1912 to 1915, Einstein worked on his theory of gravity, collaborating with mathematician Marcel Grossman. In 1915, he [published four papers](#) on general relativity.

The central idea of his work was that mass and energy cause spacetime, which can be thought of as a fabric, to curve or bend.

To illustrate this, let's look at an example. Consider a heavy item (such as a bowling ball) resting on a trampoline. It results in the surface bending. Now, if we were to drop some lighter objects, like marbles, they would move toward the bowling ball as they followed the curves on the trampoline surface.

Einstein formulated [The Field Equations](#) to mathematically describe the relation between curvature of spacetime and mass and energy.

Geodesics

Einstein also introduced the concept of geodesics in his theory of general relativity.

A geodesic is the path along which an object moves in curved spacetime, and this is the shortest path in curved spacetime. These paths appear curved when seen in

our three-dimensional space. This is equivalent to a [straight line](#) being the shortest distance between two points on a flat surface.

For example, the paths taken by planets around the Sun follow geodesics and appear as elliptical orbits.

From black hole to GPS

Einstein's special and general relativity theories have been repeatedly tested and consistently proven right.

Mercury's orbit

Einstein [published a paper](#) in which he used his theory of general relativity to correctly predict that Mercury's orbit precesses by 43 arcseconds per century.

Arcseconds are a measure of angle used in astronomy, with 60 arcseconds in one arc minute and 60 arcminutes in one degree. This means that Mercury's orbit shifts by 43 arcseconds every century, as observed from Earth, due to [gravitational forces](#).

Black holes

Black holes are regions of spacetime where the gravitational force is so strong that not even light can escape. Einstein's theory of general relativity allowed for the existence of black holes.

A few months after Einstein published his work, physicist Karl Schwarzschild found a solution to Einstein's field equations that described what we now call a [black hole](#).

However, the term "black hole" was not only coined in 1967 by astronomer John Wheeler.

Independent researchers made the first [confirmed observations](#) of a black hole in 1971, and it was named [Cygnus X-1](#).

Gravitational waves

Einstein's theory of general relativity also predicted gravitational waves, which are ripples caused by spacetimes. According to this, massive accelerating objects (like black holes or neutron stars) disrupt spacetime, causing ripples to spread in all directions at the speed of light.

These ripples carry information about their origins and were first observed in 2015 by the [LIGO observatory](#) in the US. The observatory used laser interferometers to [detect the ripples](#) in spacetime caused by the collision of two massive black holes.

GPS

The [global positioning system](#) (or GPS) is a system of satellites in orbit around the Earth that provide precise time and location information.

The technology works by constantly transmitting time and position signals from satellites, forming the basis of many modern technologies, such as navigation systems and emergency response services.

Einstein's theories of relativity are crucial to its functioning due to time dilation effects, which would cause the satellite clocks to go out of sync and run at rates different from the [clocks on Earth](#).

If it weren't for Einstein's theories of relativity, GPS systems would not work.

Conclusion

There we have it, folks! Einstein's theories of relativity have revolutionized our understanding of spacetime and gravity, paving the way for discoveries and technology.

Despite its overall success, the theory has some limitations under extreme conditions. For example, Einstein's field equations break down at singularities, regions in spacetime where the gravitational force is infinite, such as at the center of black holes and the [Big Bang](#).

Additionally, they still need to fully integrate with the Standard Model, leaving the quest for a Unified Theory of Everything open.

Time, long considered a fundamental aspect of our universe, might actually be an illusion stemming from [quantum entanglement](#), according to a new study.

This idea presents a fresh perspective on the longstanding issue physicists face: the inconsistency of time in our best theories of the universe, which hinders the quest for a unified "theory of everything."

Researchers propose that time is a result of quantum entanglement, the mysterious connection between particles separated by vast distances. Their findings, published in the [journal Physical Review A](#), could offer a clue to solving the problem of time.

"There exists a way to introduce time which is consistent with both classical laws and quantum laws, and is a manifestation of entanglement," explained Alessandro Coppo, a physicist at the [National Research Council of Italy](#) and the study's lead author. "The correlation between the clock and the system creates the emergence of time, a fundamental ingredient in our lives."

Time, long considered a fundamental aspect of our universe, might actually be an illusion stemming from quantum entanglement. (CREDIT: Nicolle Rager Fuller, National Science Foundation/Science Photo Library)© The Brighter Side of News

In [quantum mechanics](#), time is a fixed phenomenon, an unchanging flow from past to present. It remains external to the ever-changing quantum systems it measures and can only be observed through changes in external entities, like the hands of a clock.

Conversely, [Einstein's theory of general relativity](#), which deals with larger objects like stars and galaxies, depicts time as intertwined with space, capable of warping and dilating under high speeds or strong gravitational fields. This discrepancy creates a significant conflict between our two best theories of reality, preventing the formulation of a coherent theory of everything.

"It seems there is a serious inconsistency in quantum theory," Coppo said. "This is what we call the problem of time."

Related Stories

[Scientists discover why time appears to move faster as we age](#) [Groundbreaking discovery could redefine our understanding of time and reality](#) [First time ever: Quantum entanglement used to measure the Earth's rotation](#)

To address this, the researchers revisited the Page and Wootters mechanism, a theory proposed in 1983. It suggests that time emerges through quantum entanglement between one object and another acting as a clock. In an unentangled system, [time does not exist](#), and the universe appears frozen and unchanging.

Applying this mechanism to two entangled but noninteracting theoretical quantum states—a vibrating harmonic oscillator and a set of tiny magnets acting as a clock—the researchers found their system aligned perfectly with the [Schrödinger equation](#), which predicts the behavior of quantum objects. Instead of traditional time, their version of the equation ran according to the states of the tiny magnets.

While this concept isn't entirely new, the team's next step was groundbreaking. They repeated their calculations, assuming first that the magnet clock and then the harmonic oscillator were macroscopic objects. The equations simplified into those used in classical physics, suggesting that [time's flow](#) is a consequence of entanglement even on large scales.

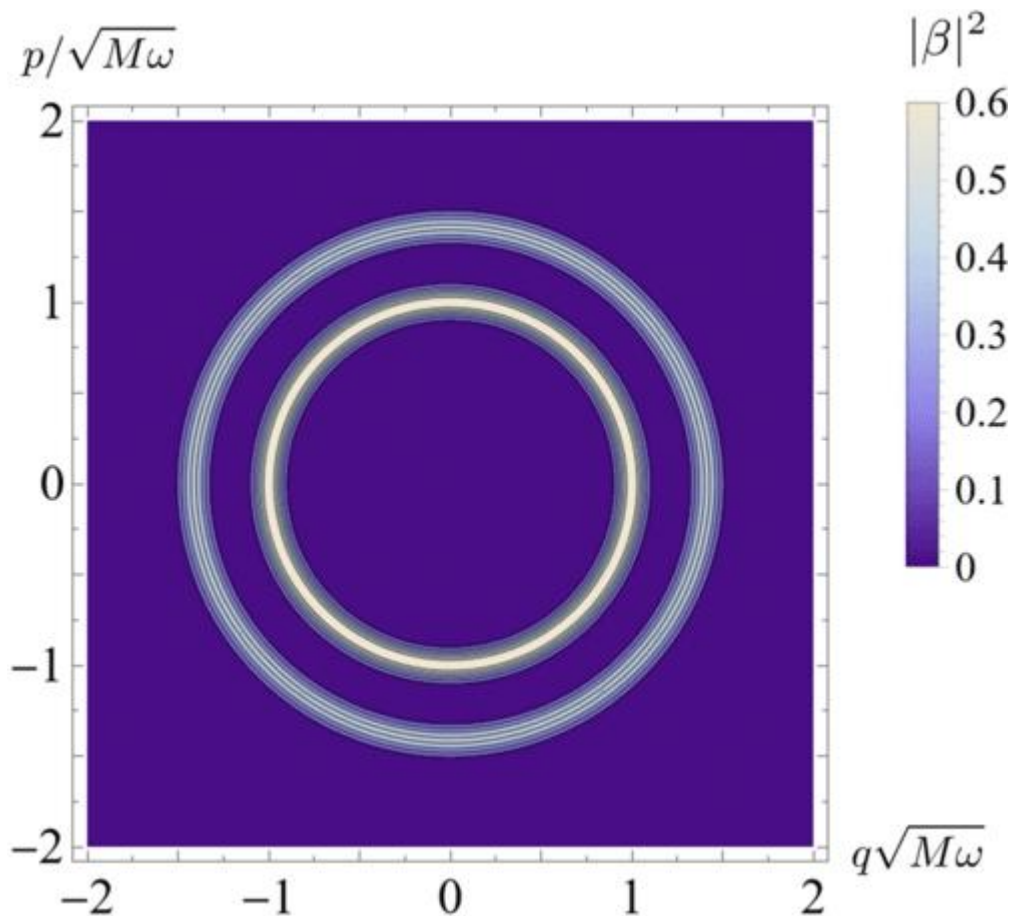

The contour plot of the marginal probability distribution related to $|\beta|^2$ with respect to the evolving system phase-space coordinates. (CREDIT: Physical Review A)© The Brighter Side of News

"We strongly believe that the correct and logical direction is to start from quantum physics and understand how to reach classical physics, not the other way around," Coppo asserted.

Despite the intriguing possibilities, other physicists urge caution. They find the idea of the Page and Wootters mechanism fascinating but note that it has yet to produce testable results.

"Yes, it is mathematically consistent to think of the universal time as the entanglement between [quantum fields](#) and quantum states of 3D space," commented Vlatko Vedral, a professor of quantum information science at the [University of Oxford](#), who was not involved in the work. "However, no one knows if anything new or fruitful will come out of this picture—such as modifications to quantum physics and general relativity, and corresponding experimental tests."

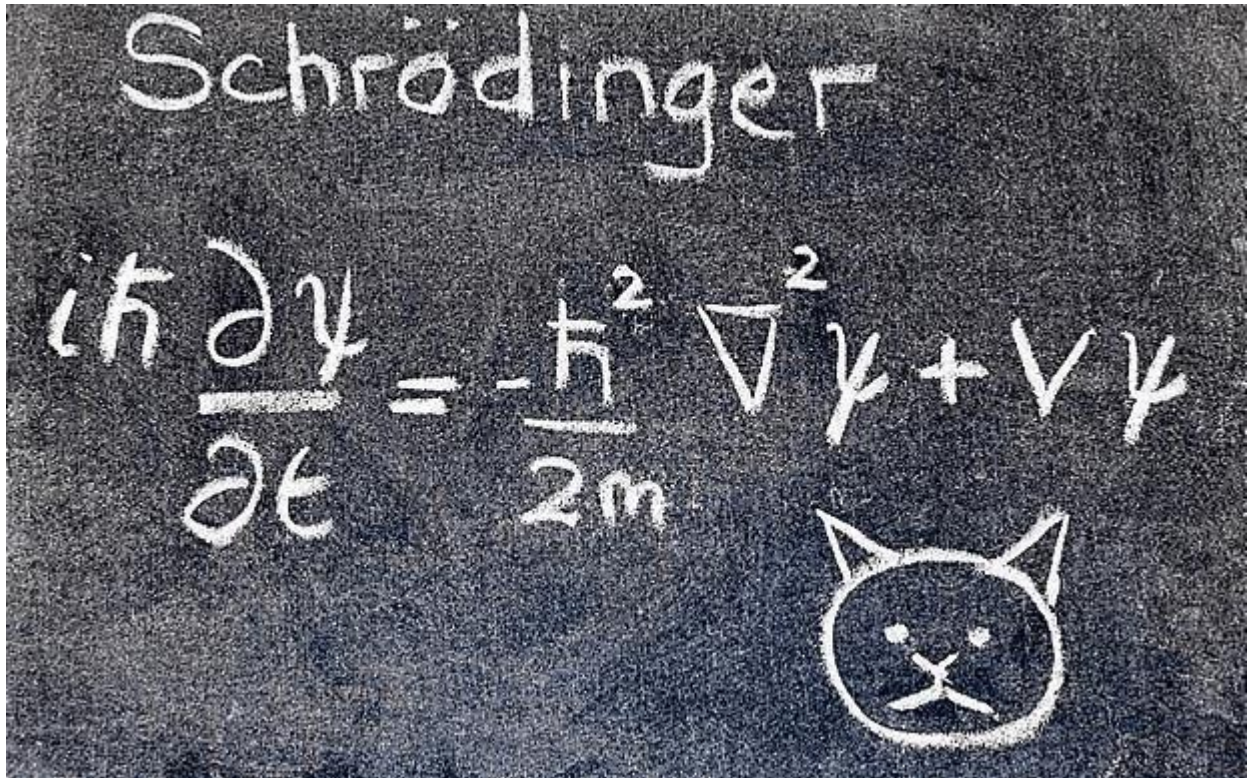

Researchers found their system aligned perfectly with the Schrödinger equation, which predicts the behavior of quantum objects. (CREDIT: CC BY-SA 3.0)© The Brighter Side of News

Despite these doubts, building theories of time from quantum mechanics might still be a promising approach, provided they can be validated through experiments.

"Maybe there is something about entanglement where it plays a role," suggested Adam Frank, a theoretical physicist at the [University of Rochester](#) in New York, who was not involved in the study. "Maybe the only way to understand time is not from some God's-eye perspective, but from the inside, from a perspective of asking what is it about life that manifests such an appearance of the world."

In summary, this new perspective on time as an emergent property from quantum entanglement could open up new avenues for [understanding the universe](#).

However, it remains crucial to develop these theories in ways that can be experimentally tested to bridge the gap between quantum mechanics and general relativity.

They believe a tweak here and an extra dimension there could unlock a whole new way to understand reality.© Iana Kunitsa - Getty Images

- To square Albert Einstein's General Theory of Relativity with quantum mechanics requires some currently unknown physics, and that's led some scientists to question if Einstein's theory could use some tweaking.
- One of these ideas is a concept known as 'fuzzy gravity,' which requires extra dimensions and discrete spacetime to explain irregularities.
- However, any theoretical deviations from general relativity occur on immensely small levels currently unobservable by even the most powerful particle accelerators.

One of the biggest headaches of the physics world is that Albert Einstein's [General Theory of Relativity](#)—which does a pretty good job of explaining physical phenomena on the macro-level, at least until you get [sucked into a black hole](#)—doesn't quite square with the quantum world.

While some physicists work within the bounds of these theories to find a Grand Unified Theory (the holy grail of physics), others are proposing tweaks or wholesale changes to Einstein's masterwork.

One of these general relatively rethinks is Modified Newtonian Dynamics (MOND), which eschews the need for hypothetical (yet observational) concepts like [dark matter](#). But most physics agree that MOND comes with its own heap of issues.

Other hypotheses, instead, take a different approach—simply tweaking aspects of general relativity to make them a bit more agreeable with [quantum mechanics](#). This is the category into which the idea of 'fuzzy gravity' fits comfortably.

Three scientists from the National Technical University in Athens, Greece published a paper in the journal [Progress of Physics](#) that details this slightly altered take on Einstein's magnum opus. At its most basic, the idea posits that spacetime might be discrete rather than continuous. This isn't a new idea—for decades, physicists have pondered if [spacetime](#) is more like a tapestry of points, similar to the way that matter is made up of atoms. At the moment, however,

we're just not capable of probing space to such small Planck lengths (or 10^{20} times the diameter of a proton).

But the new hypothesis doesn't stop there. Instead, it puts forth the idea that spacetime is non-commutative in addition to being discrete.

The commutative property, to put it simply, states that when variables are rearranged, they equal the same thing. Addition and multiplication, for example, are commutative ($5+8 = 8+5$). Subtraction and division, on the other hand, are non-commutative. This theory of fuzzy gravity posits that "the order in which spatial coordinates are multiplied matters," according to *Advanced Science News*—a definite departure from usual [geometry](#).

"From the beginning, the quantum [theory](#) challenged the classical notions of commutativity," the paper reads. "Searching on the possible use in Physics of the notion of noncommutative geometry, by considering the coordinates as noncommutative quantities, it can be linked to a potential quantum structure that might occur at very small distances (Planck scale)."

Of course, as is often the case with alternative hypotheses, the idea of 'fuzzy gravity' comes with some caveats—chiefly, that it helps describe quantum gravity, but none of the other fundamental forces (such as [electromagnetism](#), the weak and strong nuclear forces) or elemental particle interactions. In this paper, the authors attempt to unify interactions by using higher dimensional spacetime. As [Advanced Science News](#) describes:

To try and solve this, the team followed a general approach to unifying interactions by considering higher-dimensional spacetime... They found that if time and three spatial dimensions are extended by extra, discrete, and noncommutative directions, that their interaction with each other and usual four-dimensional spacetime would result in interacting elementary particles very similar to what we observe.

However, 'fuzzy gravity' hypothesizes that things really wouldn't deviate from general relativity until around a Planck length, which is much too small for even the most advanced [particle accelerators](#) to probe. Until physicists can square some of the wonky physics of the quantum and classical realm, scientists will continue searching for answers—in four dimensions and beyond.

The foundation of nearly all quantum information applications—such as computation and communication—rely on the quantum properties of superposition and entanglement.

In quantum computers—which hold the promise of performing complex calculations that today's classical computers can't handle—superposition and entanglement go hand in hand. While superposition allows a physical system—like a particle—to be in multiple states simultaneously, entanglement links particles, allowing them to form an inseparable state, even when they are separated by a large distance.

"They are the fundamental properties of quantum mechanics, the determining properties for many applications," said Wenchao Ge, assistant professor of physics at the University of Rhode Island, whose theoretical research explores fundamental issues in quantum mechanics. "Without superposition and entanglement, no quantum-enhanced application would exist."

In recent theoretical research, Ge and collaborators Jiru Liu and M. Suhail Zubairy, members of the Institute for Quantum Science and Engineering at Texas A&M University, explored the relationship between the two fundamental resources to quantum physics.

They established a single way to quantify the two properties, defining a mathematical description of each. Their paper, "Classical-Nonclassical Polarity of Gaussian States," was [published](#) in *Physical Review Letters*.

"It's theoretical proof that the two properties—superposition and entanglement—can be interchanged quantitatively," said Ge. "Our work discovers an important quantitative relation between these two fundamental quantum effects for a large class of quantum states. This work opens a new direction of research in quantifying these resources for quantum information processing."

The ability to quantify the properties allows for the conversion of these two resources from one state to the other. "Sometimes in quantum mechanics, one resource may be difficult to prepare," said Ge. "If you could have the other type of resource, you can convert between these resources."

In the field of quantum mechanics, there has been interest in understanding and application of nonclassical resources—resources that do not have a classical counterpart, such as a particle in a state with a negative probability. But research has fallen short in coming up with a satisfactory unified evaluation of both properties, Ge said.

The researchers wanted to explore the internal relationship between the two quantum properties, which determine many high-level quantum applications such as computation, communication and sensing. To do so, they looked at Gaussian states, a large class of states in quantum mechanics known for their ease in reproducing and manipulation during quantum information experiments.

Previous studies have looked at quantitative relationships of the two properties for two-mode or three-mode (two or three particle) Gaussian states. The team advanced the research, proposing a single measure for quantum superposition in one-particle systems and entanglement between multiple particles (two or three particle modes).

The new measure, "classical-nonclassical polarity," is shown to unify the two effects quantitatively for a large class of Gaussian states, Ge said.

Ge said the work can form a foundation for exploring other quantum properties for information applications such as quantum sensing and computing.

"This is the first step in finding a quantitative relation between these two properties," said Ge. "For Gaussian states, we have only proved this relationship up to three modes. It may be useful to study four, five or even more bipartite. We conjecture such a quantitative relation even beyond Gaussian states.

"For physics research, we want to see what are the properties, what are the fundamental principles," he added. "If we discover a fundamental principle, there could be far-reaching applications."

More information: Jiru Liu et al, Classical-Nonclassical Polarity of Gaussian States, *Physical Review Letters* (2024). DOI: [10.1103/PhysRevLett.132.240201](https://doi.org/10.1103/PhysRevLett.132.240201). On arXiv: DOI: [10.48550/arxiv.2310.12104](https://doi.org/10.48550/arxiv.2310.12104)

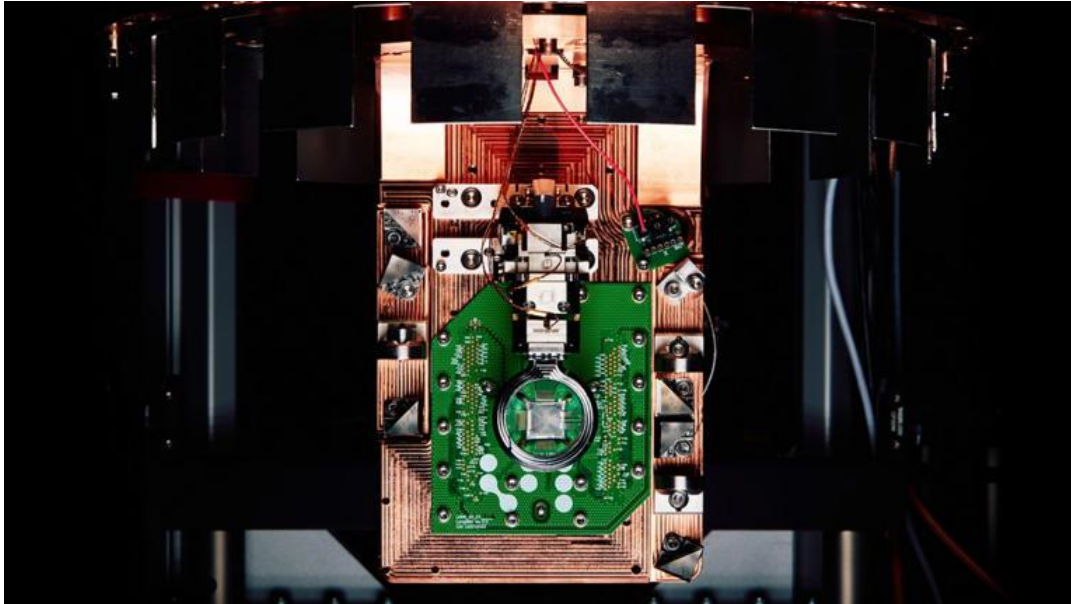

Oxford Ionics sets new world record, slashes quantum errors by 1,300%

Researchers from Oxford Ionics, a quantum computing company backed by the University of Oxford's physics department, have developed and tested a new protocol for finding and rejecting faulty qubits.

They claim their protocol has set a new world record for quantum state preparation and measurement (SPAM). It shows a 13-fold decrease in SPAM errors compared to the current best method, making it the best-performing and most reliable quantum platform in the industry.

The researchers believe their new SPAM protocol would play a major role in improving existing quantum systems and in the development of next-generation quantum computers.

The significance of high SPAM fidelity

SPAM is the process in quantum computing that prepares qubits in specific quantum states and measures those states after quantum operations.

It is critical in ensuring the accuracy and reliability of quantum computation because the quality of results delivered by a quantum system directly depends on how well the qubits are prepared.

If qubits are incorrectly prepared, it leads to errors and makes it difficult to read or [measure qubit states](#) at the end of a computation.

So, basically, to build a functional quantum computer, it is essential to achieve high SPAM fidelity, i.e., high accuracy in qubit preparation and measurement.

“Low errors in SPAM, along with two-qubit and single-qubit gates, are therefore among the three most important metrics when evaluating the precision and accuracy of a quantum computer,” the study authors [note](#).

Testing the new protocol

Oxford Ionics focuses on trapped-ion technology. This approach involved trapping ions using electric or magnetic fields.

In the next step, the state of these ions is changed using lasers to process quantum information. Finally, the state of the ions is measured to obtain the results of the [quantum computation](#).

The new SPAM protocol is a combination of standard SPAM methods and a series of mid-circuit non-demolition (QND) measurements. The latter allows scientists to monitor qubits and detect issues without interrupting ongoing calculations.

To test the new SPAM protocol, they employed it for three different qubit encodings in a single trapped $^{137}\text{Ba}^+$ ion.

“For all three, we achieve the lowest reported SPAM infidelities of $7(4) \times 10^{-6}$ (optical qubit), $5(4) \times 10^{-6}$ (metastable-level qubit), and $8(4) \times 10^{-6}$ (ground-level qubit),” the study authors [said](#).

The protocol achieved the [highest SPAM fidelity](#) of 99.9993% (a world record). These results prove that it's great at identifying and eliminating erroneous qubits and can be used for any quantum system.

"The world records set by Oxford Ionics, in tandem with this unique approach, bring it one step closer to delivering quantum computers capable of delivering widespread commercial impact," the study authors added.

- Bose-Einstein condensates (BECs) are a kind of quantum "magnifying glass" in which atoms lose their identity and behave as a singular quantum wave function.
- Scientists have now devised a method to create a one-dimensional BEC using light, called a "photon gas."
- A new study reveals that the restriction of one-dimensional space blurs the BECs condensation point, opening up new avenues of researching in quantum optical effects.

Bose-Einstein condensates (BECs), the fifth form of [matter](#)—the existence of which was originally predicted in the 1920s, but not observed until the 1990s—helps physicists explore the nature of the quantum world. Because BECs coalesce into a single quantum mechanical entity at temperatures approaching absolute zero, they allow experts to study quantum properties on a macro level. Because of this unique trait, some describe the matter [as a quantum "magnifying glass."](#)

Since their first discovery in 1995, studies have altered BECs into different forms to further probe [quantum mechanics](#) in different ways. Earlier this summer, for example, scientists from Columbia University created molecular BECs as a pathway to forming more exotic forms of matter. Now, scientists from the University of Bonn and the University of Kaiserslautern-Landau (RPTU) in Germany have created a one-dimensional gas made of light called a "photon gas," and the team tested hypothetical predictions about the transition into this exotic phase for the first time. The results were published in the journal [Nature Physics](#).

Of course, to form a one-dimensional BEC made of photons, the scientists needed to get things cold—very, very cold. So, they implemented an ingenious

method to form an ultracold gas within the microcavity of two highly reflective mirrors, placed only a micrometer apart (one thousandth of a millimeter). A tiny container of dye solution was then excited using the lasers, and when a photon collided with a dye [molecule](#), those photons were cooled until the matter condensed. By modifying these reflective surfaces, scientists were able to alter a property of the BEC known as dimensionality.

“We were able to apply a transparent polymer to the reflective surfaces to create microscopically small protrusions,” Julian Schulz, a co-author of the study from RPTU, said in a [press statement](#). “These protrusions allow us to trap the [photons](#) in one or two dimensions and condense them.”

Scientists know that, in two dimensions, there is a precise temperature at which condensation occurs—similar to how [water](#) freezes at a certain temperature. But when things get down to one dimension, things get less clear.

“So-called thermal fluctuations take place in photon gases but they are so small in two dimensions that they have no real impact. However, in one dimension these fluctuations can—figuratively speaking—make big waves,” Frank Vewinger, the senior author of the study from the University of Bonn, said in a press statement. “We have now been able to investigate this behavior at the transition from a two-dimensional to a one-dimensional photon [gas](#) for the first time.”

These “fluctuations,” as described Vewinger, disrupt the quantum “oneness” of these one-dimensional systems and cause different regions of the gas begin acting differently—the authors describe this process as the phase transition being “smeared out.” But this new phase of matter is still a “degenerate quantum gas,” meaning its properties are still governed by quantum mechanics. Continuing with the water metaphor, it’s forming icy water at very low temperatures without actually [freezing](#). The condensation point is blurred because the dimensionality restricts the photons’ movements.

“These polymers act like a type of gutter, but in this case for [light](#),” physicist Kirankumar Karkihalli Umesh, from the University of Bonn, said in a news release. “The narrower this gutter is, the more one-dimensionally the gas behaves.”

While the [scientists](#) admit that this is just basic research, these gasses could help explore new quantum applications. In other words, BECs continue to be the go-to method for scouting the unknown frontiers of the quantum world.

The most recent email you sent was likely encrypted using a tried-and-true method that relies on the idea that even the fastest computer would be unable to efficiently break a gigantic number into factors. Quantum computers, on the other hand, promise to rapidly crack complex cryptographic systems that a classical computer might never be able to unravel. This promise is based on a quantum factoring algorithm proposed in 1994 by Peter Shor, who is now a professor at MIT.

But while researchers have taken great strides in the last 30 years, scientists have yet to build a quantum computer powerful enough to run Shor's algorithm.

As some researchers work to build larger quantum computers, others have been trying to improve Shor's algorithm so it could run on a smaller quantum circuit. About a year ago, New York University computer scientist Oded Regev proposed a major theoretical improvement. His algorithm could run faster, but the circuit would require more memory.

Building off those results, MIT researchers have proposed a best-of-both-worlds approach that combines the speed of Regev's algorithm with the memory-efficiency of Shor's. This new algorithm is as fast as Regev's, requires fewer quantum building blocks known as qubits, and has a higher tolerance to quantum noise, which could make it more feasible to implement in practice.

In the long run, this new algorithm could inform the development of novel encryption methods that can withstand the code-breaking power of quantum computers.

"If large-scale quantum computers ever get built, then factoring is toast and we have to find something else to use for cryptography. But how real is this threat? Can we make quantum factoring practical?"

"Our work could potentially bring us one step closer to a practical implementation," says Vinod Vaikuntanathan, the Ford Foundation Professor of Engineering, a member of the Computer Science and Artificial Intelligence Laboratory (CSAIL), and senior author of a [paper](#) describing the algorithm.

The paper's lead author is Seyoon Ragavan, a graduate student in the MIT Department of Electrical Engineering and Computer Science. The research was presented at the 2024 International Cryptology Conference ([Crypto 2024](#)).

Cracking cryptography

To securely transmit messages over the internet, service providers like email clients and messaging apps typically rely on RSA, an encryption scheme invented by MIT researchers Ron Rivest, Adi Shamir, and Leonard Adleman in the 1970s (hence the name "RSA"). The system is based on the idea that factoring a 2,048-bit integer (a number with 617 digits) is too hard for a computer to do in a reasonable amount of time.

That idea was flipped on its head in 1994 when Shor, then working at Bell Labs, introduced an algorithm which proved that a quantum computer could factor quickly enough to break RSA cryptography.

"That was a turning point. But in 1994, nobody knew how to build a large enough quantum computer. And we're still pretty far from there. Some people wonder if they will ever be built," says Vaikuntanathan.

It is estimated that a quantum computer would need about 20 million qubits to run Shor's algorithm. Right now, the largest quantum computers have around 1,100 qubits.

A quantum computer performs computations using quantum circuits, just like a classical computer uses classical circuits. Each quantum circuit is composed of a series of operations known as quantum gates. These quantum gates utilize qubits, which are the smallest building blocks of a quantum computer, to perform calculations.

But quantum gates introduce noise, so having fewer gates would improve a machine's performance. Researchers have been striving to enhance Shor's algorithm so it could be run on a smaller circuit with fewer quantum gates.

That is precisely what Regev did with the circuit he proposed a year ago.

"That was big news because it was the first real improvement to Shor's circuit from 1994," Vaikuntanathan says.

The quantum circuit Shor proposed has a size proportional to the square of the number being factored. That means if one were to factor a 2,048-bit integer, the circuit would need millions of gates.

Regev's circuit requires significantly fewer quantum gates, but it needs many more qubits to provide enough memory. This presents a new problem.

"In a sense, some types of qubits are like apples or oranges. If you keep them around, they decay over time. You want to minimize the number of qubits you need to keep around," explains Vaikuntanathan.

He heard Regev speak about his results at a workshop last August. At the end of his talk, Regev posed a question: Could someone improve his circuit so it needs fewer qubits? Vaikuntanathan and Ragavan took up that question.

Quantum ping-pong

To factor a very large number, a quantum circuit would need to run many times, performing operations that involve computing powers, like 2 to the power of 100.

But computing such large powers is costly and difficult to perform on a quantum computer, since quantum computers can only perform reversible operations. Squaring a number is not a reversible operation, so each time a number is squared, more quantum memory must be added to compute the next square.

The MIT researchers found a clever way to compute exponents using a series of Fibonacci numbers that requires simple multiplication, which is reversible, rather than squaring. Their method needs just two quantum memory units to compute any exponent.

"It is kind of like a ping-pong game, where we start with a number and then bounce back and forth, multiplying between two quantum memory registers," Vaikuntanathan adds.

They also tackled the challenge of error correction. The circuits proposed by Shor and Regev require every quantum operation to be correct for their algorithm to work, Vaikuntanathan says. But error-free quantum gates would be infeasible on a real machine.

They overcame this problem using a technique to filter out corrupt results and only process the right ones.

The end-result is a circuit that is significantly more memory-efficient. Plus, their error correction technique would make the algorithm more practical to deploy.

"The authors resolve the two most important bottlenecks in the earlier quantum factoring algorithm. Although still not immediately practical, their work brings quantum factoring algorithms closer to reality," adds Regev.

In the future, the researchers hope to make their algorithm even more efficient and, someday, use it to test factoring on a real quantum circuit.

"The elephant-in-the-room question after this work is: Does it actually bring us closer to breaking RSA cryptography? That is not clear just yet; these improvements currently only kick in when the integers are much larger than 2,048 bits. Can we push this algorithm and make it more feasible than Shor's even for 2,048-bit integers?" says Ragavan.

More information: Space-Efficient and Noise-Robust Quantum Factoring: eprint.iacr.org/2023/1501.pdf

By giving each qubit extra frequencies, scientists can get them to work together to process calculations as if they were a part of a single quantum computer. © Getty Images/Eugene Mymrin

Physicists have created a new model for quantum computers that could more easily scale them up and make them more powerful than previously imagined.

The new theory, outlined in a study published May 21 in the journal [PRX Quantum](#), proposes linking qubits, the fundamental workhorses of quantum computers, over vast distances to work as if they were part of a single super-powerful machine.

Where bits are used in classical computing to process data in binary states of 1 or 0, and in sequence, [quantum computing](#) uses qubits (which rely on the laws of [quantum mechanics](#)) to encode data in a superposition of 1 and 0. This means data can be encoded in both states simultaneously. Each qubit operates in a given frequency.

These qubits can then be stitched together through [quantum entanglement](#) — where their data is linked across vast separations over time or space — to process calculations in parallel. The more qubits are entangled, the more exponentially powerful a quantum computer will become.

Entangled qubits must share the same frequency. But the study proposes giving them "extra" operating frequencies so they can resonate with other qubits or work on their own if needed.

The road to quantum supremacy

With enough entangled qubits, future quantum computers could perform calculations that would have taken a classical computer thousands of years in just a few seconds. But you need a quantum processor with millions of qubits to achieve this state of "quantum supremacy," whereas the [most powerful today have just 1,000 qubits](#).

But maintaining the stability between entangled qubits, so that you can process data, is difficult and requires complex electronics and equipment. Scaling up the qubits in a quantum computer so it's powerful enough to leapfrog [today's most powerful supercomputers](#) also represents a major hurdle — as you would also need to scale up that complex circuitry.

[**Quantum compasses closer to replacing GPS after scientists squeeze key refrigerator-sized laser system onto a microchip**](#)

But the scientists propose that by giving each qubit extra frequencies, they can get them to work together to process calculations as if they were a part of a single quantum computer. This is despite being potentially separated over vast distances. It means that instead of one massive quantum processor that is difficult to maintain, you can use several smaller ones linked together.

“Each qubit in a quantum computer operates at a specific frequency. Realizing the capabilities unique to a quantum computer relies on being able to control each qubit individually via a distinct frequency, as well as to link pairs of qubits by matching their frequencies,” study lead author [Vanita Srinivasa](#), assistant professor of quantum information at the University of Rhode Island, said in a [statement](#).

Fitting qubits together like 'LEGO blocks'

The scientists said that by applying oscillating voltages, they could generate extra frequencies for each qubit. By doing this, you can link multiple qubits together by tapping into newly generated shared frequencies, without having to match their original frequencies. The qubits can then be linked together, yet also be controlled individually using their original frequencies.

“This approach to scaling is like building a larger system using fixed-size LEGO blocks, which are like individual modules, and connecting them using longer pieces that are strong enough to maintain the connection between the blocks for a sufficient time before external influences break the links,” Srinivasa said in the statement.

The model aims to overcome challenges that scientists will face in scaling up quantum processors in the future. These are normally fabricated with semiconductors and use billions of tiny transistors that can be harnessed to make compact qubits. However, simply adding more and more qubits to a quantum processor will one day be infeasible, the scientists said.

Using the new model, the researchers believe future quantum computers will be built in a modular way — with smaller arrays of qubits in quantum processors that are connected using robust and long-range entangled links. This will render

them more powerful and capable of much faster calculations than is feasible using the technology that we have today.

It is easy to list the advantages of quantum computing these days. Still, none of those lists involve using it to harvest energy, teleport it elsewhere, and store it for future use. That's exactly what researchers at Purdue University in the US have achieved in the past year, even though the idea was proposed over a decade ago.

Quantum physics is still an emerging field, and much remains unknown about what can be accomplished. Scientists in the field keep proposing new theories that are tested extensively before they become laws that govern our understanding of the field.

One such law states that a perfectly perfect space does not exist in the quantum realm. Even if the space were cleaned up of the tiniest of atoms, tiny flickers of quantum fields would still remain in it and even have quantum properties such as entanglement.

Teleporting energy

[Quantum entanglement](#) is a fascinating phenomenon in quantum physics that explains the behavior of a group of particles whose quantum state cannot be described independently of the others. This entanglement continues even when a large distance separates the particles.

In 2008, Masahiro Hotta, a researcher at Tohoku University in Japan, proposed that the tiny flickers of quantum fields in empty spaces, when entangled, could be used to teleport energy. The idea remained a thought experiment for over a decade until quantum computing research picked up pace.

When researchers attempted Hotta's experiments, they were indeed able to teleport the energy, but they hit a new hurdle. The teleported energy leaked into the environment was lost and could not be stored.

A research team led by Sabre Kais, a chemistry, electrical, and computer engineering professor at Purdue University in the US, now has a solution using quantum computing.

Qubits as a store of energy

Kais' team solved the energy storage problem using the most basic quantum computing component, [quantum bits](#) or qubits. In their experiment, the researchers used qubits in their lowest energy state.



Artist's rendering of energy, representational stock image. Image credit: Pobytov/iStock

In a simpler world, this would be qubits at zero energy. But we know that even the emptiest places have some energy due to tiny flickers of quantum fields. If the two qubits were entangled and then separated, then even the slightest of actions would change their energy state.

For instance, if measurements of the first qubit's energy state were made, it would increase its energy slightly, which would be reflected in the entangled qubit as well. This change would not be visible at the other end.

However, if the person making the measurement determined exactly how much extra energy the entangled qubits have, they would be able to extract this energy from the entangled qubit and bring the two qubits back to their lowest energy state.

According to Kais' research, this extra energy could be stored in another qubit for future use. The researchers have tested this approach using simulations on a quantum computer.

One could argue that this is more of a simulation than a real experiment, but it is also the closest to a real experiment one could get in a simulation, considering qubits were calculating whether qubits could store energy, and there was high agreement.

Next, Kais and his team want to use this energy to carry out chemical reactions, making it a much more real-world application.

The Cosmic Debate: Divine Design or Random Chance?

Story by Sarah Norman

Limitations

Science, while a powerful tool for understanding the universe, has its limitations, particularly in addressing questions of existence beyond empirical observation. Many argue that phenomena such as consciousness, the origins of the universe, and the intricacies of life suggest the possibility of a higher power or divine intelligence.

Moral and Ethical Laws

Moral and Ethical Laws: Some argue that the presence of moral and ethical laws in human consciousness and societies suggests a divine origin, aligning with the idea of a creator who imbues the universe with purpose and order.

Fine Tuning of the Universe

Fine-Tuning of the Universe: The universe's physical constants and laws are remarkably fine-tuned for the existence of life. Some argue this precision suggests intentional design rather than random chance.

The Big Bang Theory

The Big Bang Theory: The Big Bang theory, which posits that the universe had a beginning, is seen by some as consistent with the idea of a creator initiating the universe.

Cosmic Background Radiation

©Getty Images Cosmic Background Radiation: The uniformity of cosmic background radiation is often interpreted as a remnant of a primordial event, which some believe could be the result of a deliberate act of creation.

The Anthropic Principle

The Anthropic Principle: This principle suggests that the universe's properties are perfectly suited for human life, implying that it might have been designed with purpose.

Order and Complexity

Order and Complexity: The intricate order and complexity observed in natural systems, from galaxies to biological processes, are sometimes cited as evidence of an intelligent designer.

Irreducible Complexity

Irreducible Complexity: Certain biological systems are considered by some to be too complex to have evolved through natural processes alone, suggesting a possible guiding hand.

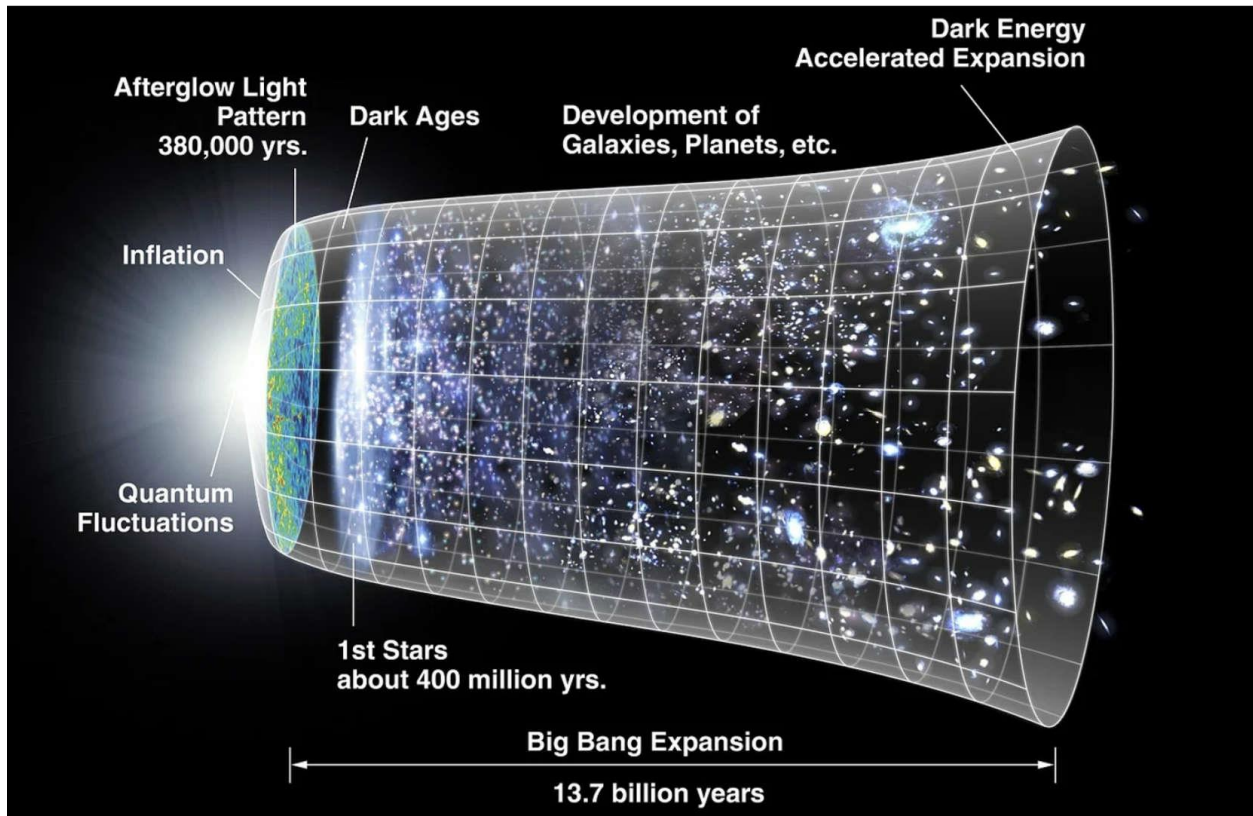

The Origin of Life

The Origin of Life: The spontaneous emergence of life from non-life remains one of science's biggest mysteries, leading some to argue that a creator might have played a role.

Mathematical Precision

Mathematical Precision: The universe's underlying mathematical framework, which describes everything from subatomic particles to cosmic structures, is viewed by some as indicative of purposeful design.



Quantum Mechanics

Quantum Mechanics: The strange and counterintuitive nature of quantum mechanics is sometimes interpreted as evidence of a creator's involvement in the fundamental aspects of reality.

The Laws of Thermodynamics

The Laws of Thermodynamics: The application of these laws, particularly the law of entropy, raises questions about the universe's origin and complexity, which some argue points to a creator.

Mathematical Laws of the Universe

Mathematical Laws of the Universe: The existence and effectiveness of mathematical laws in explaining natural phenomena are seen by some as evidence of a purposeful design behind the universe.



Quantum 'pseudogap' puzzle cracked, to help superfast floating trains

For many years, quantum physicists have been trying to understand the pseudogap state of materials. Finally, a team of researchers has unraveled the various mysteries surrounding the pseudogap using a special algorithm

Pseudogap refers to the strange behavior observed in some materials such as cuprates (copper oxides), which behave as superconductors at extreme temperatures (i.e. below -140°C), but at higher temperatures exhibit the properties of a semiconductor or a regular metal.

In such materials, there exists an unusual partial gap in electron energy levels. This pseudo-gap appears because some electron pairs start forming at higher temperatures, but they don't fully [transition](#) into the superconducting state.

Why and how the pseudogap appears have been unknown for decades, but not anymore. In their new study, the researchers reveal the answer to these questions.

"Our discovery will help scientists in their quest for room-temperature superconductivity, a holy grail of condensed matter physics that would enable

lossless power transmission, faster MRI machines, and superfast levitating trains,” the study authors [note](#).

Pseudogap is tricky even for powerful computers

What makes the pseudogap state so difficult to decode is [quantum entanglement](#), which makes electrons interconnected, meaning that the state of one electron instantly affects the state of the other, no matter how far apart they are.

“Computing the properties of these materials is extraordinarily challenging—you can’t simulate them exactly on even the most powerful computer you can think of. You have to resort to clever algorithms and simplified models,” Antoine Georges, one of the study authors and a physicist at the Polytechnic Institute of Paris, said.

In order to overcome this challenge, the researchers took the help of [the Hubbard model](#), a mathematical framework used in physics to describe how electrons move and interact in a material.

This model considers materials like cuprates as chessboards, with their electrons behaving like pawns, hopping from one box to the adjacent ones. Electrons can either be in an up or down spin state. Plus, they can only share the same location if their spins are opposite, which results in an energy expense.

Next, to calculate the behavior of electrons from the Hubbard model, the researchers employed the diagrammatic Monte Carlo algorithm. It can analyze electron interactions occurring across the entire chess board at once, which is not possible with other commonly used algorithms.

“The approach of diagrammatic Monte Carlo is very different. We can simulate, in principle, an infinite number of particles,” Riccardo Rossi, one of the researchers and a quantum scientist at the Swiss Federal Institute of Technology Lausanne, said.

The algorithm decoded the pseudogap state

The use of diagrammatic Monte Carlo turned out to be a great success. It revealed many details that were previously unknown.

For instance, the study authors discovered that as material in the pseudogap approaches absolute zero temperatures, “electrons organize into rows of matching spins separated by rows of empty squares.”

Such arrangements are called stripes. Some previous studies also mention the possibility of such formations but this study is the first to confirm it.

The study authors also found that the pseudogap state of a material is actually the result of checkerboard patches appearing in electron arrangements. “As soon as those checkerboard patches appeared in the electron arrangements, the materials fell into the pseudogap,” they note.

These findings could help scientists in developing practical room-temperature superconductors. Plus, it could also contribute to their [understanding of quantum gas](#) simulation — an exciting field that combines quantum optics and condensed matter physics.

However, “Further work involving controlled ground-state studies will be necessary to clarify the fate of the pseudogap at low temperatures, which remains an outstanding question,” the study authors added.

The [study](#) is published in the journal *Science*.

Quantum Entanglement At The Highest Energy Yet Observed At CERN

Story by Dr. Alfredo Carpineti



Artist's impression of a quantum-entangled pair of top quarks. - Image Credit: CERN© IFL Science

Experiments at the Large Hadron Collider have shown that top quarks, the heaviest of all elementary particles, can end up being entangled. Such quantum entanglement is happening at the highest possible energy we have ever measured, 12 orders of magnitude higher than standard experiments.

The intriguing results were seen by the ATLAS experiment last year in [preliminary results](#) and it has now been confirmed by a fellow experiment, Compact Muon Solenoid (CMS). Both detectors report spin entanglement between top quarks with a statistical significance larger than [five standard deviations](#). In physics terms, it means that it is definitely a detection and not a fluke.

"While particle physics is deeply rooted in quantum mechanics, the observation of quantum entanglement in a new particle system and at much higher energy than previously possible is remarkable," ATLAS spokesperson Andreas Hoecker said in a [statement](#). "It paves the way for new investigations into this fascinating

phenomenon, opening up a rich menu of exploration as our data samples continue to grow."

Quantum entanglement is a fascinating state that does not happen at the level that we are at – only particles experience it. Basically, two or more particles being entangled means that they are in a single state. No matter how far apart they are, interaction with one will affect the other and that state will change immediately.

This might seem counterintuitive or breaking some law. How could a particle on Mars entangled with one on Earth change the state instantaneously? Shouldn't the information be limited to the speed of light? Well, no information is passed through – it's just the state has changed. Quantum entanglement remains mysterious and fragile: The state can be disturbed and the particles go back to being unconnected.

If quantum entanglement was not weird enough on its own, let's look at the [Top quarks](#). They are fundamental particles, like a heavier cousin of the up quark found inside protons and neutrons. Protons and neutrons are the particles that make up all the atoms in existence. Top quarks are so heavy that they have the same mass as a [caffeine](#) molecule.

They are also pretty unstable, decaying in 5×10^{-16} seconds. That interval is to one second like one second is to 100 million times the age of the universe. The decay, though, is very important and allows us to study so many intriguing other particles. In the case of this work, the CMS team also looked at top quark pair forming with very high momentum.

The pairs could not have sent information to each other without violating causality (and breaking the speed of light). But entanglement was still there as it was expected to be. With this confirmation, researchers can start understanding this quantum phenomenon at the current extreme of energy.

"With measurements of entanglement and other quantum concepts in a new particle system and at an energy range beyond what was previously accessible, we can test the Standard Model of particle physics in new ways and look for signs

of new physics that may lie beyond it," explained CMS spokesperson Patricia McBride.

In a cutting-edge development that has sent shockwaves through the scientific community, researchers at [University College London](#) (UCL) have unveiled a radical theory that seeks to reconcile two pillars of modern physics – quantum mechanics and Einstein's general theory of relativity.

These two theories, which have been the foundation of physics for over a century, have long been at odds with each other, and their unification has remained an elusive quest.

The image depicts an experiment in which heavy particles (illustrated as the moon), cause an interference pattern (a quantum effect), while also bending spacetime. The hanging pendulums depict the measurement of spacetime. (CREDIT: Isaac Young)© The Brighter Side of News

Today, we dive into the world of [quantum gravity](#), a field of study that aims to bridge the gap between the quantum realm, which governs the behavior of particles at the smallest scales, and the macroscopic world, where gravity shapes the very fabric of spacetime.

While the prevailing consensus has been that Einstein's theory of gravity must be modified to fit within the framework of quantum theory, a new theory, coined as a "[postquantum theory of classical gravity](#)," challenges this assumption in a thought-provoking way.

The Clash of Titans: Quantum Mechanics vs. General Relativity

[Quantum mechanics and general relativity](#), developed by Albert Einstein in the early 20th century, have both stood the test of time and have been proven accurate in their respective domains. However, when it comes to merging these two theories into a single, comprehensive framework, the scientific community has hit a roadblock.

Quantum mechanics, which beautifully describes the behavior of particles at the subatomic level, operates in a probabilistic realm characterized by wave functions and quantum states.

Related Stories

[Groundbreaking study reaffirms Einstein's General Theory of Relativity](#) [New methods will allow for better tests of Einstein's general theory of relativity](#) ['Einstein Shape' tiles will revolutionize material science](#)

In contrast, general relativity paints a different picture of the universe, where gravity arises from the [curvature of spacetime](#) caused by massive objects. While these theories excel in their own domains, they clash when brought together, leading to mathematical inconsistencies and contradictions.

A New Approach: Spacetime as Classical

Enter Professor Jonathan Oppenheim and his team at UCL, who have challenged the status quo with their groundbreaking theory. In two parallel papers published simultaneously, they propose a novel perspective that suggests [spacetime](#) may remain classical and unaffected by quantum mechanics.

This theory, as described in a paper published in [Physical Review X \(PRX\)](#), refrains from modifying spacetime itself and instead modifies quantum theory.

The weighing of a mass - an experiment proposed by the UCL group which constrain any theory where spacetime is treated classically. (CREDIT: Isaac Young)© The Brighter Side of News

The core tenet of this theory is that spacetime remains classical, not subject to the constraints of quantum theory. Instead, quantum theory is tweaked to account for intrinsic unpredictability mediated by spacetime. The consequence?

Spacetime experiences random and violent fluctuations that exceed the expectations set by quantum theory. These fluctuations, if measured precisely enough, render the apparent weight of objects unpredictable.

To put their theory to the test, the researchers propose a groundbreaking experiment aimed at detecting fluctuations in mass over time. For instance, consider a 1kg mass – the standard measurement used by the [International Bureau of Weights and Measures](#) in France. If the measurements of this 1kg mass

exhibit fluctuations smaller than those required for mathematical consistency, it would challenge the new theory.

This experiment, which has far-reaching implications for our [understanding of gravity](#) and quantum mechanics, is not just theoretical but practical. It serves as a critical juncture in the ongoing debate between competing theories of quantum gravity. Professor Oppenheim, along with Professor Carlo Rovelli and Dr. Geoff Penington, leading proponents of quantum loop gravity and string theory, respectively, have even placed a 5000:1 odds bet on the outcome.

Five Years of Rigorous Testing

The UCL research group, led by Professor Oppenheim, has spent the past five years meticulously developing and examining their theory, scrutinizing its consequences from various angles.

As Professor Oppenheim puts it, "Quantum theory and Einstein's theory of general relativity are mathematically incompatible with each other, so it's important to understand how this contradiction is resolved."

Their journey has been marked by relentless exploration of the [fundamental nature of gravity](#) and the cosmos itself, probing the boundaries of our knowledge and challenging preconceived notions.

Beyond the Weight of Gravity: Implications of the Postquantum Theory

While the focus of the postquantum theory is on reconciling quantum mechanics and [general relativity](#), its implications extend far beyond the realm of gravity. One notable consequence is the elimination of the notorious "measurement postulate" in quantum theory.

This postulate, which has long perplexed physicists, posits that measurements collapse quantum superpositions into definite states. In the new theory, quantum superpositions naturally localize through their interaction with classical spacetime, obviating the need for this postulate.

Professor Oppenheim's journey to this groundbreaking theory was motivated by his attempt to unravel the mysteries of the black hole information paradox. According to [standard quantum theory](#), information cannot be destroyed.

Therefore, an object entering a black hole should somehow radiate information back out. However, this concept directly contradicts general relativity, which posits that once an object crosses a [black hole's event horizon](#), it becomes inaccessible.

The postquantum theory offers a unique perspective, suggesting that the fundamental breakdown in predictability inherent to spacetime allows for information to be destroyed, resolving this long-standing paradox.

The proposal to test whether [spacetime](#) remains classical by detecting random fluctuations in mass is just one part of the puzzle.

Another experimental proposal aims to verify the quantum nature of spacetime through a phenomenon called "gravitationally mediated entanglement." These experiments, though challenging, hold immense promise in advancing our understanding of the fundamental laws of nature.

Professor Sougato Bose, an expert in the field who was not involved in the recent UCL announcement but had previously proposed the entanglement experiment, emphasized the importance of these endeavors, stating, "Experiments to test the [nature of spacetime](#) will take a large-scale effort, but they're of huge importance from the perspective of understanding the fundamental laws of nature. I believe these experiments are within reach – these things are difficult to predict, but perhaps we'll know the answer within the next 20 years."

At the heart of this theory lies a delicate interplay between quantum particles, [such as atoms](#), and the fluctuations in classical spacetime. These fluctuations, if the theory holds, must occur on a scale yet to be detected but should be large enough to impact quantum particles' behavior.

The proposed experiments seek to find this elusive balance, shedding light on whether spacetime remains classical or succumbs to quantum mechanics at microscopic scales.

In the words of Professor Oppenheim, "Now that we have a consistent fundamental theory in which spacetime does not get quantized, it's anybody's guess." The journey has just begun, and the [future of physics](#) has never looked more intriguing.

Background information

Quantum mechanics background: All the matter in the universe obeys the laws of quantum theory, but we only really observe quantum behavior at the scale of atoms and molecules.

Quantum theory tells us that particles obey Heisenberg's uncertainty principle, and we can never know their position or velocity at the same time. In fact, they don't even have a definite position or velocity until we measure them. Particles like electrons can behave more like waves and act almost as if they can be in many places at once (more precisely, physicists describe particles as being in a "[superposition](#)" of different locations).

Quantum theory governs everything from semiconductors which are ubiquitous in computer chips, to lasers, to superconductivity to radioactive decay. In contrast, we say that a system behaves classically if it has definite underlying properties. A cat appears to behave classically – it is either dead or alive, not both, nor in a superposition of being dead and alive.

Why do cats behave classically, and small particles quantumly? We don't know, but the [postquantum theory](#) doesn't require the measurement postulate, because the classicality of spacetime infects quantum systems and causes them to localize.

Gravity background: Newton's theory of gravity, gave way to Einstein's theory of general relativity (GR), which holds that gravity is not a force in the usual sense. Instead, heavy objects such as the sun, bend the fabric of spacetime in such a way that causes the earth to revolve around it.

Spacetime is just a mathematical object consisting of the three dimensions of space, and time considered as a fourth dimension. General relativity predicted the [formation of black holes](#) and the big bang. It holds that time flows at different rates at different points in space, and the GPS in your smartphone needs to account for this in order to properly determine your location.

Note: Materials provided above by the [The Brighter Side of News](#). Content may be edited for style and length.

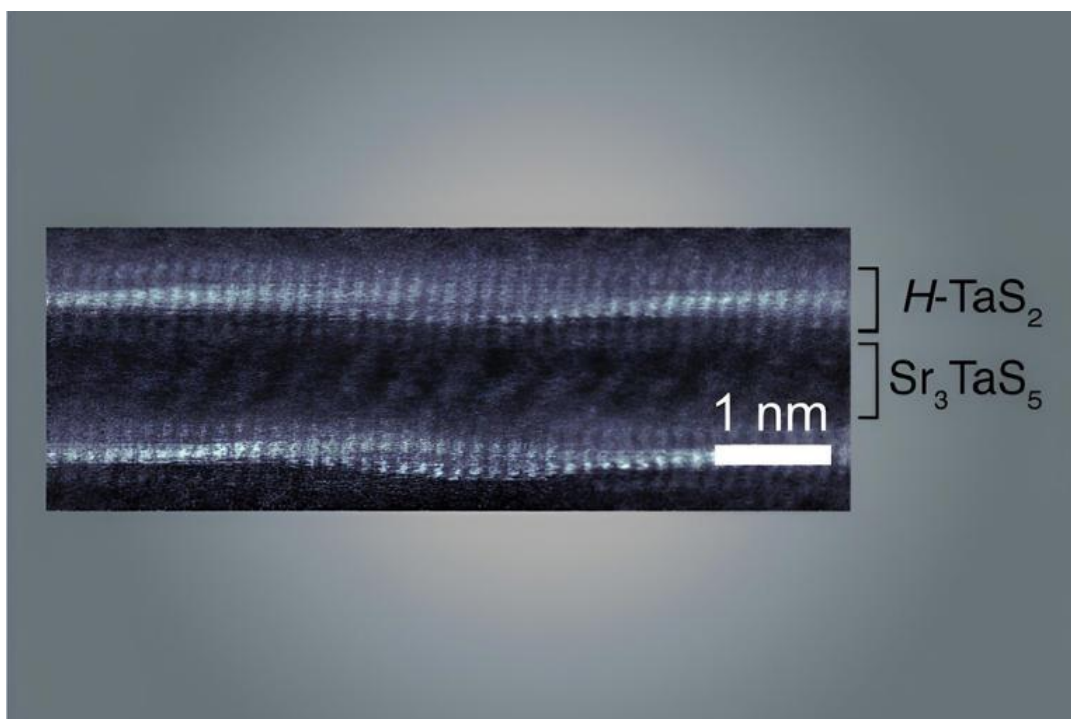

Transmission electron micrograph of a new material sporting wavy layers of atoms. Credit: Checkelsky Lab, MIT

MIT physicists and colleagues have created a new material with unusual superconducting and metallic properties, thanks to wavy layers of atoms only billionths of a meter thick that repeat themselves over and over to create a macroscopic sample that can be manipulated by hand. The large size of the sample makes it much easier to explore its quantum behavior, or interactions at the atomic scale that give rise to its properties.

The work, [reported](#) in *Nature*, is also important because the material was synthesized through rational design. In other words, the recipe for the material is based on the team's insights into the materials science and chemistry of this family of materials. As a result, the physicists are confident they can create even more new materials with unusual properties.

Further, although there are other materials that form wavy atomic structures, the team believes that this is the most perfect. The nanoscopic layers of waves are uniform across an entire crystal, which is composed of thousands of these corrugated layers.

"Such materials go beyond what one would conventionally consider a crystal—observing and understanding what new physical properties may emerge is an exciting opportunity," says Joseph Checkelsky, senior investigator of the work and Associate Professor of Physics at MIT.

2D materials

Two-dimensional materials, or those consisting of only one or a few layers of atoms, have captured physicists' attention because they can be manipulated to produce materials with new, unusual properties. For example, rotating, or twisting, one or more of the layers at a slight angle creates a unique pattern called a moiré superlattice that can give rise to phenomena including superconductivity and unconventional magnetism.

But moiré materials are both difficult to make—they must be assembled manually—and difficult to study because of their atomic dimensions. Checkelsky's group has been working to create analogous materials that are much easier to manipulate.

"We essentially mix powders of material, expose them to temperatures of a few hundred degrees Celsius in a furnace, and rely on chemical reactions" to naturally form macroscopic crystals with properties dictated by atomic-scale interactions. "That's the key breakthrough," says Aravind Devarakonda, MIT Ph.D., who is now an assistant professor at Columbia University. Devarakonda is first author of the current *Nature* paper.

In 2020, Checkelsky and many of the same colleagues in the current work reported the first such material created this way in the journal *Science*. That paper was accompanied by a [perspective piece](#) by Professor Leslie M. Schoop of Princeton University.

In 2021, Checkelsky and colleagues [described](#) in *Nature* the physics behind how that particular material can exhibit two different kinds of superconductivity. The new wavy material is the second member of this family of compounds.

Like a layer cake

Like a layer cake, the new material is composed of an atomically thin metallic layer of tantalum and sulfur stacked on top of a "spacer" layer composed of strontium, tantalum, and sulfur. This structure repeats over thousands of layers to create a large crystal.

Devarakonda and colleagues believe the waves form due to a mismatch in the size and structure of each layer's crystal lattice. Correspondingly, one layer—composed of tantalum and sulfur—buckles to fit atop the other, forming the wave. Imagine placing a sheet of legal paper over a sheet of regular printer paper. For the legal paper to fit atop the regular paper, some of the paper would need to buckle upward. The new structure is analogous, except that the legal paper is "pinned" to the regular paper at intervals, forming waves.

Unusual properties

Those minuscule waves, in turn, are behind the material's interesting properties. For example, at a certain temperature the material can become superconducting, where electrons travel through a material with no resistance.

In this case, "the electrons are imprinted by the structural modulations [waves]," Devarakonda says. In other words, "the superconductivity also picks up this waviness. In some parts it is strong, and in other parts it's weakened."

Similarly, the material has unusual metallic properties. That's because electrons find it much easier to flow down the troughs of a wave—or down a valley—as opposed to up and over the hills of a wave.

"So what we've done is given the electrons a directionality. It's easier for them to flow in one direction versus the other," Devarakonda says. "We've shown that by introducing the [wave] structure we can drastically change the behavior of the layers. We've planted the flag; now we and others can run with applications. By standing on the shoulders of giants, we've created an entirely new family of materials. It's completely uncharted territory that has brought unexpected outcomes, and surprises are always fun."

In addition to Devarakonda and Checkelsky, authors of this paper are Alan Chen, a graduate student in MIT's Department of Electrical Engineering and Computer Science; Shiang Fang, formerly a postdoctoral researcher in MIT's Department of Physics, now at Google Deepmind; David Graf of the National High Magnetic Field Laboratory; Markus Kriener of the RIKEN Center for Emergent Matter Science in Japan; Austin J. Akey of Harvard University; David C. Bell of Harvard; and Takehito Suzuki of Toho University.

More information: A. Devarakonda et al, Evidence of striped electronic phases in a structurally modulated superlattice, *Nature* (2024). [DOI: 10.1038/s41586-024-07589-5](https://doi.org/10.1038/s41586-024-07589-5)

Provided by Materials Research Laboratory, Massachusetts Institute of Technology

The topological quantum computer still exists only in theory but, if possible, would be the most stable and powerful computing machine in the world. However, it requires a special type of qubit (quantum bit) that has yet to be realized and manipulated. Conventional matter is made up of atoms which contain electrons, and scientists have long known that electrons are indivisible fundamental particles. Yet surprising new research shows that a weird feature of quantum mechanics can be used to produce objects that behave like half of an electron.

These "split-electrons" can act as topological qubits and might hold the key to unlocking the full power of quantum computation.

The discovery, recently [published](#) in *Physical Review Letters*, was made by Professor Andrew Mitchell at University College Dublin (UCD) School of Physics, and Dr. Sudeshna Sen at the Indian Institute of Technology in Dhanbad, who are theoretical physicists studying the quantum properties of nano-scale electronic circuits.

"The miniaturization of electronics has reached the point now where circuit components are just nanometers across. At that scale, the rules of the game are set by quantum mechanics, and you have to give up your intuition about the way things work," said Dr. Sen.

"A current flowing through a wire is actually made up of lots of electrons, and as you make the wire smaller and smaller, you can watch the electrons go through one-by-one. We can now even make transistors which work with just a single electron."

In nano-scale electronic circuits, the phenomenon of quantum interference between electrons can lead to states where electrons appear to split.

Professor Mitchell said, "In a nanoelectronic circuit, electrons going down different paths in the circuit can destructively interfere and block the current from flowing. This phenomenon has been observed before in quantum devices.

"The new thing that we found is that by forcing multiple electrons close enough together that they strongly repel each other, the quantum interference gets changed. Even though the only fundamental particles in the circuit are electrons, collectively they can behave as if the electron has been split in two."

The result is a so-called "Majorana fermion"—a particle first theorized by mathematicians in 1937 but as yet not isolated experimentally. The finding is potentially important for the development of new quantum technologies, if the Majorana particle can be created in an electronic device and manipulated.

Professor Mitchell said, "There has been a big search for Majoranas over the last few years because they are a key ingredient for proposed topological quantum computers. We might have found a way to produce them in nanoelectronics devices by using the quantum interference effect."

Quantum interference explained by the 'double-slit' experiment

When a nanoelectronic circuit is designed to give electrons the choice of two different pathways, quantum interference takes place. Professor Mitchell explained, "The quantum interference we see in such circuits is very similar to that observed in the famous double-slit experiment."

The double-slit experiment demonstrates the wave-like properties of quantum particles like the electron, which first led to the development of quantum mechanics in the 1920s. Individual electrons are fired at a screen with two tiny apertures, and the place they end up is recorded on a photographic plate on the other side.

Because the electrons can pass through either slit, they interfere with each other. In fact, a single electron can interfere with itself, just like a wave does when it passes through both slits at the same time.

Because the electrons can pass through either slit, the waves emerging on the other side can interact and recombine in complex ways, producing an interference pattern. When the peak of one wave collides with the trough of another, they cancel out—the result is that the electron cannot pass through.

"It's the same thing that is happening in a nanoelectronic circuit," said Professor Mitchell. "Quantum interference can be used to produce the kinds of qubits we need for more powerful quantum computers."

More information: Sudeshna Sen et al, Many-Body Quantum Interference Route to the Two-Channel Kondo Effect: Inverse Design for Molecular Junctions and Quantum Dot Devices, *Physical Review Letters* (2024). [DOI: 10.1103/PhysRevLett.133.076501](https://doi.org/10.1103/PhysRevLett.133.076501). On *arXiv*: [DOI: 10.48550/arxiv.2310.14775](https://doi.org/10.48550/arxiv.2310.14775)

Provided by University College Dublin

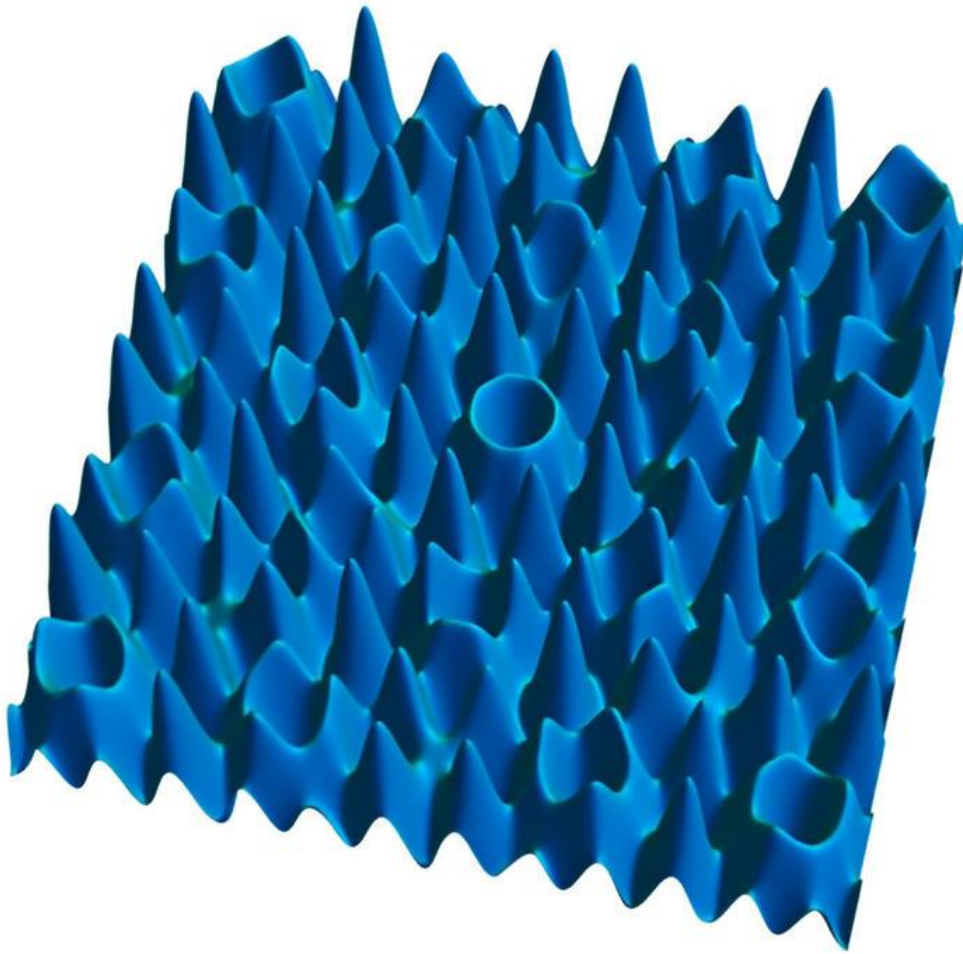

The quasiperiodic landscape in which the new Bose glass forms, similar to a Penrose tiling. Credit: Many-body Quantum Dynamics Lab / Cavendish Laboratory

Physicists from the Cavendish Laboratory in Cambridge have created the first two-dimensional version of the Bose glass, a novel phase of matter that challenges statistical mechanics. The details of the study have been [published](#) in *Nature*.

As the name suggests, the Bose glass has some glassy properties and within it all particles are localized. This means that each particle in the system sticks to itself, not mixing with its neighbors. If coffee was localized, then when stirring milk into

the coffee, the intricate pattern of black and white stripes would remain forever, instead of washing out to an average.

To create this new phase of matter, the group overlapped several laser beams to create a quasiperiodic pattern, a pattern that is long-range ordered like a conventional crystal, but not periodic, meaning that, like a Penrose tiling, it never repeats. When filling the resulting structure with ultracold atoms, cooled to nanokelvin temperatures—close to absolute zero, the atoms formed the Bose glass.

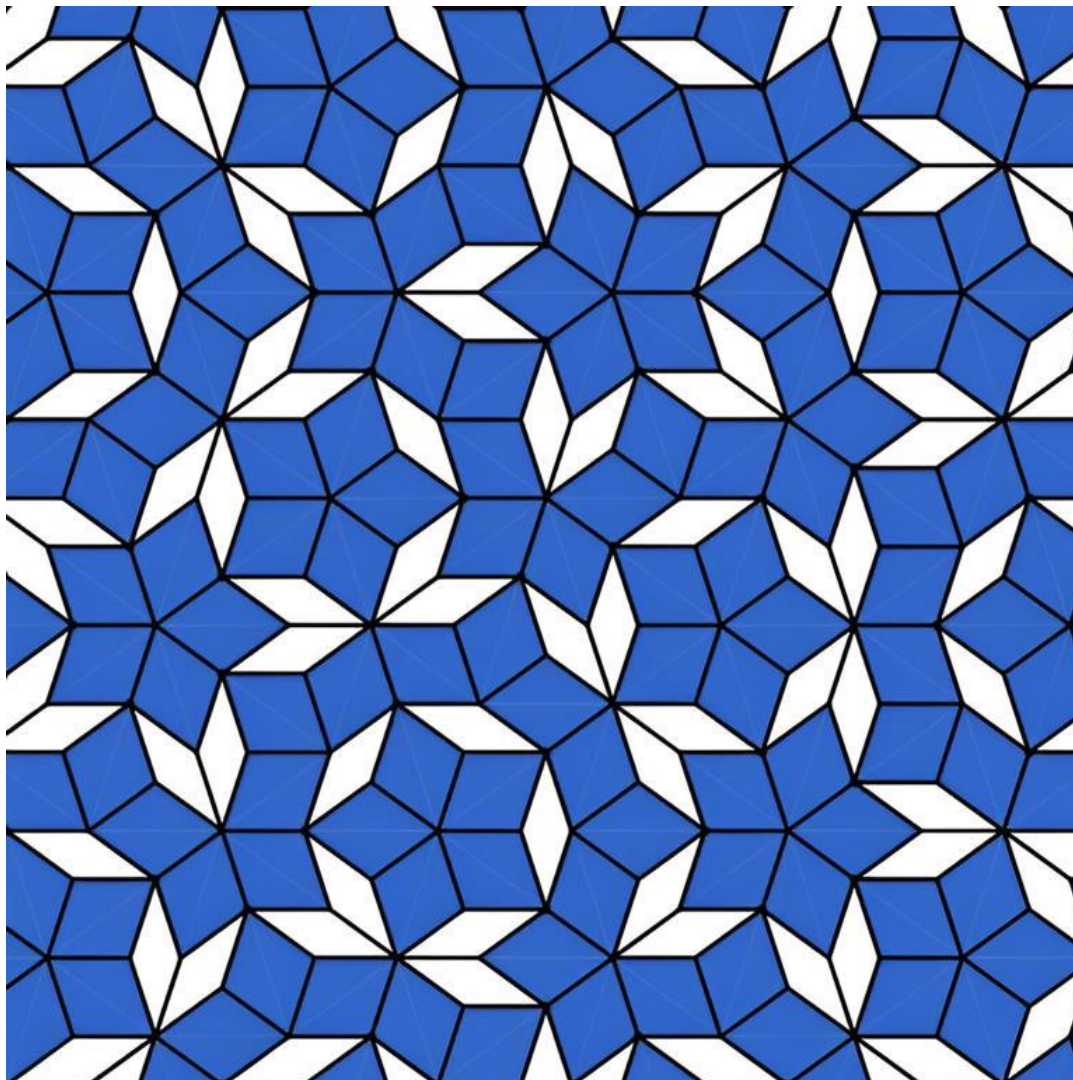

Example of a Penrose tiling. Credit: Many-body Quantum Dynamics Lab / Cavendish Laboratory

"Localization is not only one of the toughest nuts to crack in statistical mechanics, it can also help to advance quantum computing," said Professor Ulrich Schneider, Professor of Many-Body Physics at the Cavendish Laboratory, who led the study.

Since a localized system would not mix with its surroundings, quantum information stored in a localized system would be preserved for far longer.

"A big limitation of large quantum systems is that we can't model them on a computer," said Schneider. "To accurately describe the system, we have to consider all its particles and all their possible configurations, a number that grows very quickly. However, we now have a real-life 2D example which we can directly study and observe its dynamics and statistics."

Schneider and his team focus on research into quantum simulation and quantum many-body dynamics. They use ultracold atoms to study many-body effects that, in the absence of a large full quantum computer, cannot be simulated numerically.

Very often, this problem simplifies significantly because the system will always relax into a thermal state in which only the temperature of the system is important and most other details vanish. This is referred to as being ergodic and forms the basis of statistical mechanics, one of the pillars of how we understand matter.

"For instance, simply knowing the amount of milk poured in is enough to predict the final color of our coffee after a long stirring," explained Schneider. "If we want to predict the full structure of white and dark swirls during the stirring, however, it's important to know where the milk was poured in and how the stirring is done precisely."

Interestingly, the Bose glass appears to be non-ergodic. This means that it doesn't "forget its details," therefore modeling it will require all the details. This makes it a prime candidate for many-body localization.

"It's a long-term aspiration to find a system or material that has many-body localization," said Dr. Jr-Chiun Yu, the first author of the study.

"Such a material would offer many new possibilities, not only for fundamental studies, but also for building quantum computers, as quantum information stored in such a system should remain more local and not leak out into its environment—a process called 'decoherence' that plagues many current quantum computing platforms."

In the experiment, the researchers observed a surprisingly sharp phase transition from a Bose glass to a superfluid, akin to how ice melts when the temperature increases.

"A superfluid is a fluid that flows without any resistance," said Dr. Bo Song, a former Postdoctoral Research Associate in Cambridge and now an Assistant Professor at Peking University, who contributed to the research.

"Imagine particles swimming through a superfluid; there would be no friction, and the fluid would not slow them down. This property, called superfluidity, is closely related to superconductivity. Along with another quantum phase, the Mott insulator, the newly observed Bose glass and the superfluid make up the ground states of the Bose-Hubbard model that describes the physics of bosons in interacting and disordered system."

Bose glasses and superfluids are distinct phases of matter like ice and liquid water. However, like ice cubes in a cup of water, the atoms in their system can form both phases within the same experiment. The experimental results, confirming recent theoretical predictions, reveal how the Bose glass forms and evolves, so now the scientists can start thinking of applications for it.

However, though there are exciting opportunities for the future, Schneider believes we should exercise caution.

"There are many things we still don't understand about the Bose glass and its potential connection to many-body localization, both regarding their thermodynamics as well as dynamical properties. We should first focus on answering more of these questions before we try to find uses for it," concluded Schneider.

More information: Ulrich Schneider, Observing the two-dimensional Bose glass in an optical quasicrystal, *Nature* (2024). [DOI: 10.1038/s41586-024-07875-2](https://doi.org/10.1038/s41586-024-07875-2). www.nature.com/articles/s41586-024-07875-2

Provided by University of Cambridge

In a significant breakthrough, researchers at the [University of Copenhagen](#), working with [Ruhr University Bochum](#), have solved a persistent issue in quantum research. They can now control two quantum light sources instead of just one.

While this might seem trivial to those unfamiliar with quantum mechanics, it's a monumental step forward. This advancement allows the creation of [quantum mechanical entanglement](#), a phenomenon that holds immense potential for commercial technology applications.

Illustration of two a chip comprising two entangled quantum light sources. (CREDIT: NBI)© The Brighter Side of News

Controlling two quantum light sources is crucial in quantum physics. Researchers worldwide have long sought to develop stable quantum light sources and achieve entanglement—a phenomenon with almost sci-fi properties where two light sources can instantly affect each other, even over large distances. Entanglement forms the basis of [quantum networks](#) and is central to developing efficient quantum computers.

Researchers from the Niels Bohr Institute recently published their findings in the [journal Science](#). According to Professor Peter Lodahl, a key researcher in this project, this is a critical step toward advancing quantum technology and "quantizing" computers, encryption, and the internet.

"We can now control two [quantum light sources](#) and connect them. It might not sound like much, but it's a major advancement and builds upon the past 20 years of work. By doing so, we've revealed the key to scaling up the technology, which is crucial for the most groundbreaking of quantum hardware applications," says Professor Lodahl, who has been researching in this area since 2001.

Related Stories

[New study suggests time is an illusion arising from quantum entanglement](#) [Revolutionary theory finally unites quantum mechanics and Einstein's theory of general relativity](#) [Mysteries of a bizarre physical state in quantum physics finally untangled](#)

This innovation happens on a nanochip, barely larger than a human hair, developed by the researchers over recent years.

Professor Lodahl's group focuses on quantum technology using photons, light particles, to transport quantum information. Despite being a leader in this field, they could only control one light source at a time until now due to the sensitivity of these sources to external noise. The new research has succeeded in creating two identical [quantum light sources](#).

"Entanglement means that by controlling one light source, you immediately affect the other. This makes it possible to create a whole network of entangled quantum light sources, all of which interact with one another, and which you can get to perform [quantum bit operations](#) in the same way as bits in a regular computer, only much more powerfully," explains postdoc Alexey Tiranov, the lead author of the article.

A quantum bit can be both a 1 and 0 simultaneously, leading to processing power far beyond today's computer technology. According to Professor Lodahl, 100 photons from a single [quantum light source](#) contain more information than the world's largest supercomputer can process.

Using 20-30 entangled quantum light sources could potentially build a universal error-corrected quantum computer—the ultimate "holy grail" of quantum technology. Large IT companies are investing billions in this pursuit.

The biggest challenge was moving from controlling one to two quantum light sources, which required developing extremely quiet nanochips and precise control over each light source. Now, with this breakthrough, the fundamental [quantum physics research](#) is established. The task now is for other entities to build upon this work and apply quantum physics to technologies like computers, the internet, and encryption.

Photon emission is the hallmark of light-matter interaction and the foundation of photonic quantum science. (CREDIT: Science)© The Brighter Side of News

"It is too expensive for a university to build a setup where we control 15-20 quantum light sources. So, now that we have contributed to understanding the [fundamental quantum physics](#) and taken the first step along the way, scaling up further is very much a technological task," says Professor Lodahl.

The research was conducted at the Danish National Research Foundation's "Center of Excellence for Hybrid Quantum Networks (Hy-Q)" and is a collaboration between Ruhr University Bochum in Germany and the University of Copenhagen's Niels Bohr Institute.

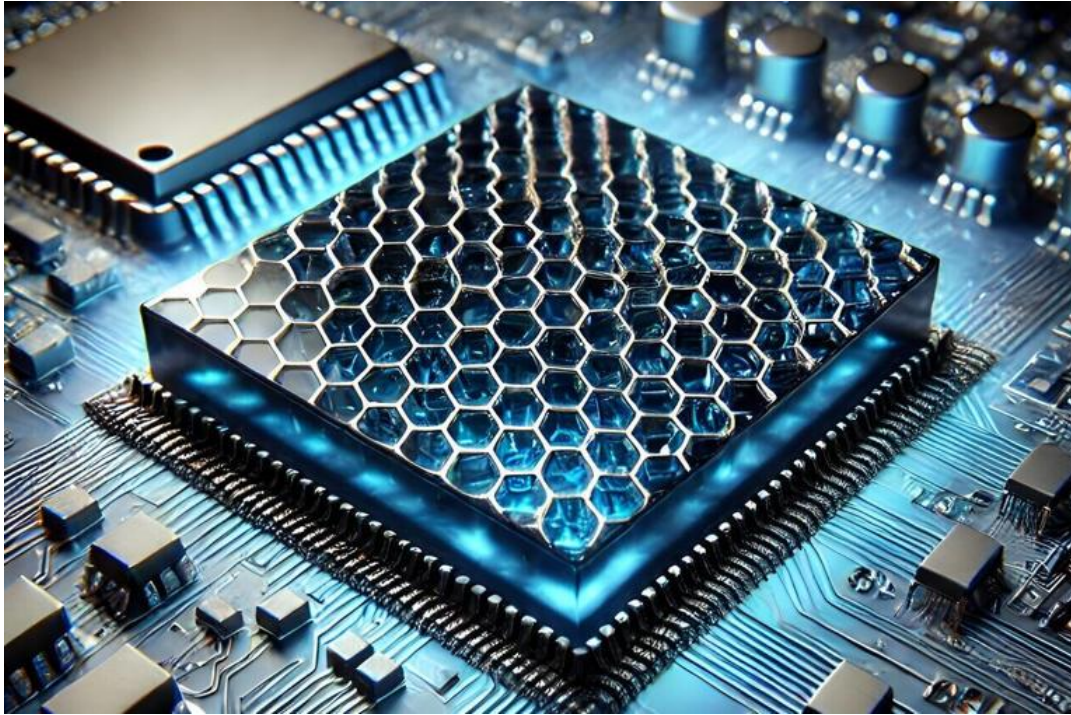

Symbolic illustration of a graphene layer on a microchip. In combination with a heavy-metal thin film and ferromagnetic monolayers, graphene could enable spintronic devices. Credit: Dall-E/Helmholtz Association of German Research Centres

Spintronics uses the spins of electrons to perform logic operations or store information. Ideally, spintronic devices could operate faster and more energy-efficiently than conventional semiconductor devices. However, it is still difficult to create and manipulate spin textures in materials.

Graphene, a two-dimensional honeycomb structure built by carbon atoms, is considered an interesting candidate for spintronic applications. Graphene is typically deposited on a thin film of heavy metal.

At the interface between graphene and heavy metal, a strong spin-orbit coupling develops, which gives rise to different quantum effects, including a spin-orbit

splitting of energy levels (Rashba effect) and a canting in the alignment of spins (Dzyaloshinskii-Moriya interaction). The spin canting effect is especially needed to stabilize vortex-like spin textures, known as skyrmions, which are particularly suitable for spintronics.

Now, however, a Spanish-German team has shown that these effects are significantly enhanced when a few monolayers of the ferromagnetic element cobalt are inserted between the graphene and the heavy metal (here: iridium). The samples were grown on insulating substrates, which is a necessary prerequisite for the implementation of multifunctional spintronic devices exploiting these effects.

The research is [published](#) in the journal *ACS Nano*.

"At BESSY II, we have analyzed the electronic structures at the interfaces between graphene, cobalt and iridium," says Dr. Jaime Sánchez-Barriga, a physicist at HZB. The most important finding: contrary to expectations, the graphene interacts not only with the cobalt, but also through the cobalt with the iridium.

"The interaction between the graphene and the heavy metal iridium is mediated by the ferromagnetic cobalt layer," Sánchez-Barriga explains. The ferromagnetic layer enhances the splitting of the energy levels.

"We can influence the spin-canting effect by the number of cobalt monolayers; three monolayers are best," says Sanchez-Barriga.

This result is supported not only by experimental data, but also by new calculations using density functional theory. The fact that both quantum effects influence and reinforce each other is new and unexpected.

"We were only able to obtain these new insights because BESSY II offers extremely sensitive instruments for measuring photoemission with spin resolution (Spin-ARPES). This leads to the fortunate situation that we can determine the assumed origin of the spin canting, i. e., the Rashba-type spin-orbit splitting, very precisely, probably even more precisely than the spin canting itself," emphasizes Prof. Oliver Rader, who heads the "Spin and Topology in Quantum Materials" department at HZB.

There are only a very few institutions worldwide that have instruments with these capabilities. The results show that graphene-based heterostructures have great potential for the next generation of spintronic devices.

More information: Beatriz Muñiz Cano et al, Rashba-like Spin Textures in Graphene Promoted by Ferromagnet-Mediated Electronic Hybridization with a Heavy Metal, *ACS Nano* (2024). [DOI: 10.1021/acsnano.4c02154](https://doi.org/10.1021/acsnano.4c02154)

Provided by Helmholtz Association of German Research Centres

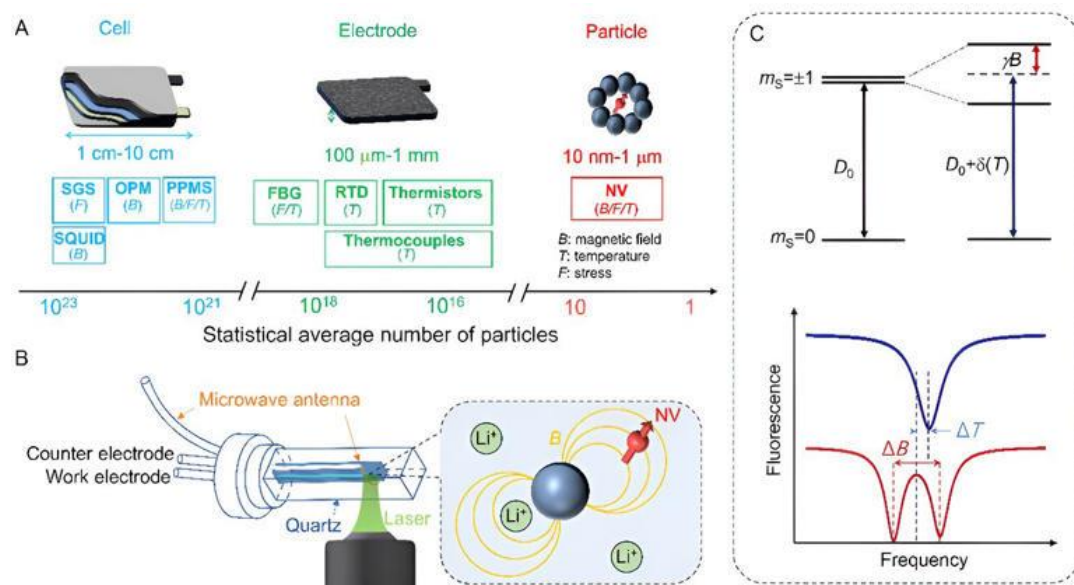

Schematic of the operando quantum sensing for the battery. Credit: Institute of Physics

Battery performance is heavily influenced by the non-uniformity and failure of individual electrode particles. Understanding the reaction mechanisms and failure modes at nanoscale level is key to advancing battery technologies and extending their lifespan. However, capturing real-time electrochemical evolution at this scale remains challenging due to the limitations of existing sensing methods, which lack the necessary spatial resolution and sensitivity.

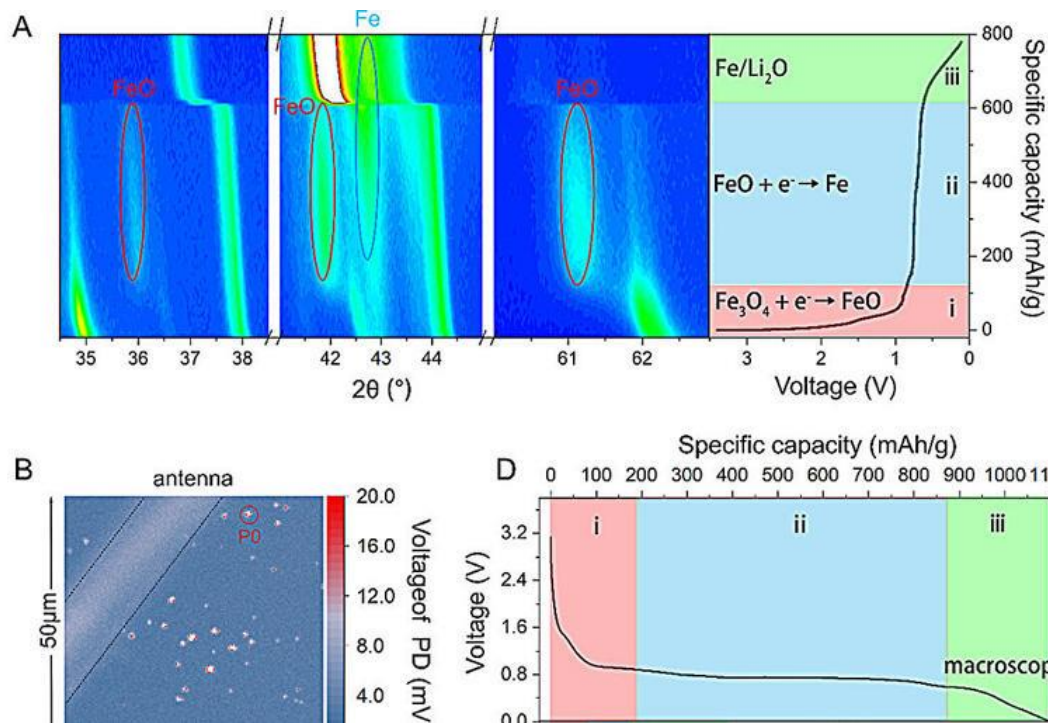

Diamond quantum sensors capture the nanoscale electrochemical evolution of the Fe₃O₄ electrode. Credit: Institute of Physics

Now, researchers from Suo Liumin's team and Liu Gangqin's team from the Institute of Physics of the Chinese Academy of Science have developed a quantum sensing approach based on diamond nitrogen-vacancy (NV) centers.

The study, titled "[Operando quantum sensing captures the nanoscale electrochemical evolution in battery](#)," was published in *Device* on September 10.

NV sensors offer spatial resolution from 1 nm to 1 μm and are sensitive to variations in temperature, stress, and magnetic fields, holding great potential for real-time, non-destructive monitoring of battery electrode particles.

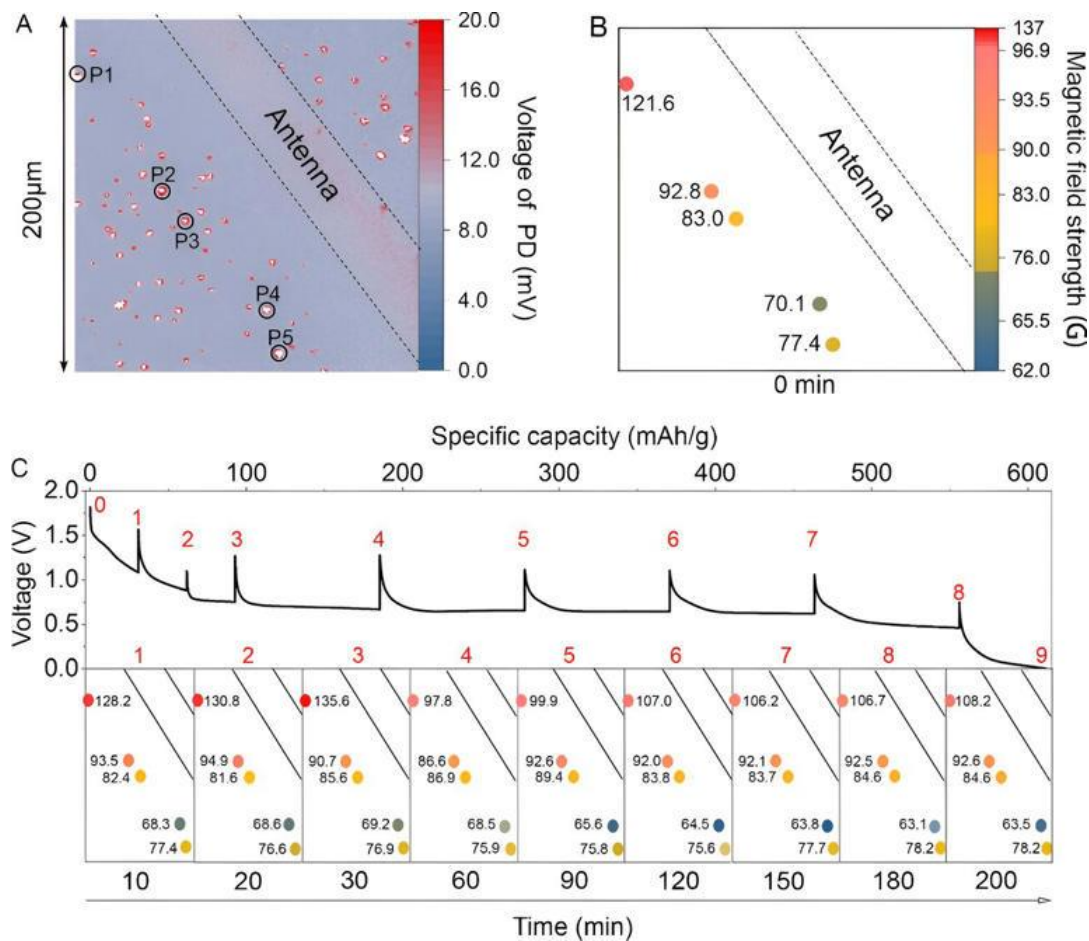

Magnetic field mapping inside the Fe₃O₄ electrode. Credit: Institute of Physics

Using an integrated device combining a quantum sensing system with a battery, researchers achieved in-situ monitoring of nanoscale active material particles, demonstrated by Fe₃O₄ electrodes.

Their findings revealed non-uniform phase transformations from Fe₃O₄ to FeO and then to Fe during discharge, with significant microscopic kinetic differences across regions.

The study also uncovered superparamagnetic behavior in Fe particles.

The significant difference in magnetic field and temperature distribution within the electrode are also revealed through multithreaded sensing in this study.

These results demonstrated the potential of diamond NV centers for wide-area, high-resolution characterization of nanoscale region within an electrode, offering new insights into material behavior and failure mechanisms.

More information: Binghang Liu et al, Operando quantum sensing captures the nanoscale electrochemical evolution in batteries, *Device* (2024). DOI: [10.1016/j.device.2024.100521](https://doi.org/10.1016/j.device.2024.100521)

Provided by Chinese Academy of Sciences

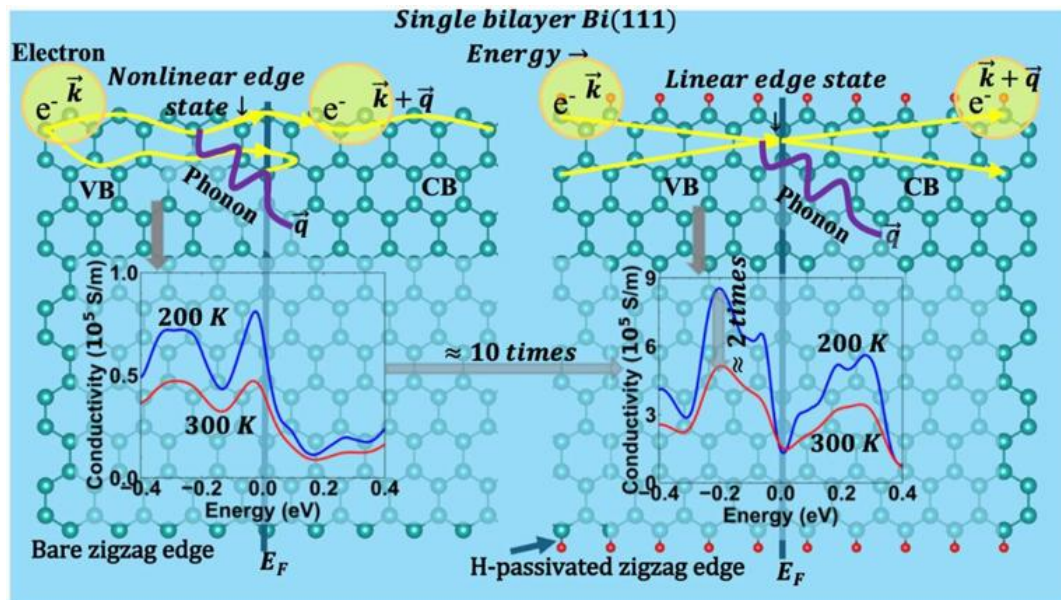

Electron-phonon interactions at linear and nonlinear electronic edge states, demonstrating impact on energy transport in these edge states. Credit: *Nanoscale* (2024). DOI: 10.1039/D4NR02172J

Topological insulators raise the exciting hope of realizing lossless energy transport, which is true at ultralow temperatures. However, topological insulators fail to maintain this lossless 'magic' at room temperature.

Researchers from Monash University, part of the FLEET Center, have uncovered new insights into the efficiency of topological insulators, illuminating the significant disparity between their magic lossless energy transport at ultralow temperatures and the detrimental issues that arise at room temperature.

The [study](#), which was published in *Nanoscale*, investigates why topological insulators face serious challenges in maintaining their feature in a practical working environment, particularly by the role of electron-phonon interactions.

Topological insulators, particularly two-dimensional (2D) topological insulators, are well-known for their unique feature of conducting electricity through the boundary/edge while the bulk surface remains electrically insulating.

This unique feature allows one-way carrier transport without backscattering, with the resulting negligible scattering-induced electrical resistance giving rise to expectations of dissipationless carrier transport.

Indeed, at ultralow temperatures, these topological insulators often exhibit dissipationless carrier transport, lining up with the expectation. However, sustaining this feature faces a serious challenge when the temperatures rise towards room temperature, where phonons (quanta of lattice vibrations) come into play with carriers.

The role of electron-phonon interactions

This study delivers a thorough analysis of interplay between carrier and phonon, and energy transport in the 2D topological insulator under different temperatures.

The interplay between electron and phonon (i.e., electron-phonon interactions) plays a crucial role in the significant increase in electrical resistance observed.

Theoretical modeling revealed electron-phonon scattering to be a significant source of backscattering at the topological edge states, with the strength of interactions strongly correlated to dispersion of the electronic edge states.

The interactions increase significantly with temperature, and are much stronger at the nonlinearly dispersed edge states of native edges compared to the linearly dispersed edge states of passivated edges, causing a significant energy dissipation in the temperature range of 200–400 K.

This study therefore illuminates the divergence between the performance at ultralow temperature and at practical, operating room temperature.

"As we considered both linear and nonlinear edge dispersions in this study, our results can be applicable to a diverse range of topological insulators," said Enamul Haque, lead author of the study.

Improved fundamental understanding of the role of electron-phonon scattering at the edges of 2D topological insulators is considered vital to progressing the technology of 2D topological insulator-based future electronics. However, previous work has focused largely on surface states of 3D topological insulators and insulating surfaces of 2D topological insulators.

"Our findings could play a crucial role for advancing the applications of topological insulators in practical electronic devices," says Haque.

The understanding from this study can guide the search for new quantum materials or how to overcome the existing limitations. By overcoming these issues at room temperature, scientists can advance in realizing the full-potential applications of topological insulators in practical technologies, for example, quantum transistors and quantum devices.

"A clear understanding of electron-phonon interactions in the topological edge states can help develop strong quantum decoherence in qubits, which would potentially enhance the stability and scalability of quantum computers," said Professor Nikhil Medhekar, lead researcher and FLEET Chief investigator.

More information: Enamul Haque et al, Electron–phonon interactions at the topological edge states in single bilayer Bi(111), *Nanoscale* (2024). [DOI: 10.1039/D4NR02172J](https://doi.org/10.1039/D4NR02172J)

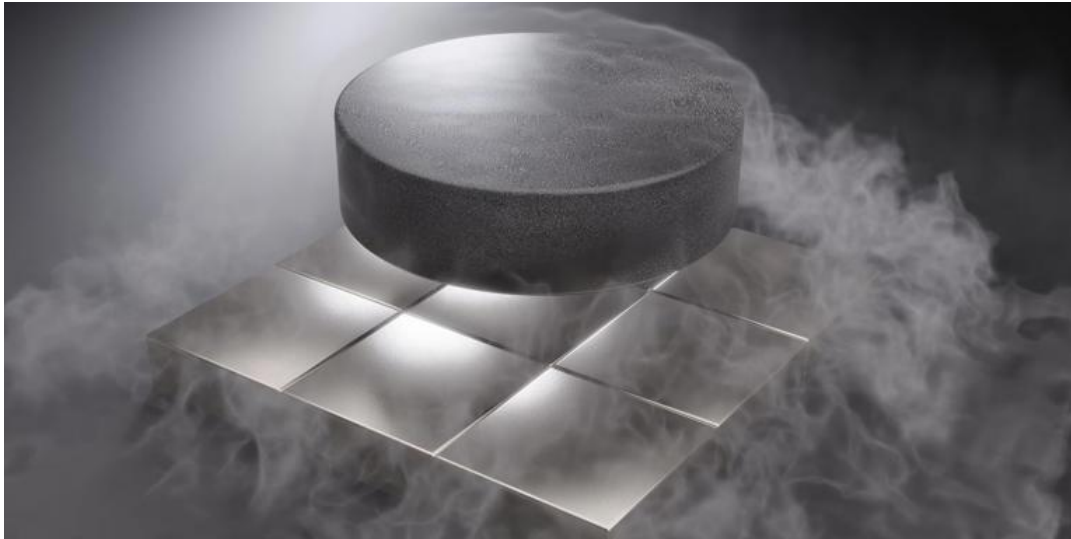

The power of magnets could be the key to going from extremely cold superconductors to ... less extremely cold superconductors. © Peter Hansen - Getty Images

- The secret to more plentiful, unconventional superconducting materials could lie in an “exotic physics” trigger called the Griffiths singularity.
- After 55 years, physicists are finally beginning to show that this landmark singularity can also describe 3D and solid materials.
- If Griffiths singularities can be studied and tailored across more materials, we may find superconductors that are within way more people’s reach, which could in turn massively change the study of quantum computing systems.

Scientists in China are on the lookout for a way to better understand [superconductors](#). And as it turns out, the secret to more plentiful unconventional superconducting materials could lie in an “exotic physics” trigger called the Griffiths singularity. The team behind this investigation recently published a [new paper](#) on the subject in the journal *National Science Review*.

The Griffiths singularity is named for physicist Robert Griffiths, who first laid out his theory over 50 years ago. In 1969, he wrote a paper detailing how a particular [magnet](#)—a ferrous or iron-containing material—showed unusual behavior above the temperature of what’s called its quantum phase transition (QPT). That’s notable, because for quantum mechanics, the phase transition occurs at absolute zero—it’s comparable to freezing, melting, and vaporizing in

classical physics. And if something was different after that point, it must have occurred during the key reaction at absolute zero.

Griffiths' core observation—that his magnet must have shown a surprising variable during transition—became known as the Griffiths singularity. "The quantum Griffiths singularity (QGS) is a phenomenon driven by quenched disorders that break conventional scaling invariance and result in a divergent dynamic critical exponent during [quantum](#) phase transitions (QPT)," the scientists explained in their new paper.

And after 55 years, physicists are finally beginning to show that his landmark singularity can also describe 3D and solid [materials](#). With that information in hand, scientists say, they can further study and improve other high-temperature unconventional superconductors with a similar makeup.

The unconventional superconductors in this new research are the iron pnictides, or ferropnictides, made of a combination of [iron](#) and arsenic (plus other elements). They're set apart from traditional superconductors in a couple of different ways, and were discovered in the early 2000s.

The most common form of superconductivity—at least, that we observe today—happens when very, very cold matter (we're talking almost [absolute zero](#)) becomes what is called a Bose-Einstein condensate (BEC)—sometimes referred to as the fifth form of matter—which was theorized about and discovered beginning over 100 years ago. But ferropnictides don't rely on being induced into a BEC state, and they can superconduct at much higher (still not high, just... less cold) temperatures.

In a typical quantum [phase](#) transition—the superconductor-insulator transition—scientists expect to find a homogeneous material that superconducts. But with a Griffiths-compatible material, the scientists wrote in the paper, "distinct superconducting islands ('rare regions') emerge." That's because the transition that produces these materials is *not* homogeneous.

These "islands" show where the Griffiths singularities have occurred while the metal material transitions from its room temperature state to a superconducting one. And in this paper, the scientists claim, they've shown for the first time that they can induce and observe these hot spots in a 3D sample of an iron pnictide superconductor. This comes after experiments showed that these hot spots were

found in [2D](#) materials, here [meaning “thin”](#) or just one molecule thick. Over time and progressive experiments, scientists have shown that they can create Griffiths singularities at more and more temperatures and in ranges of other variables.

So, what does this all mean? Well, high temperature superconductors—like the iron pnictides and others that can superconduct at even higher temperatures—have the potential to blow the barn door open on superconductor research. That’s because the materials and [equipment](#) required to cool to, say, 50 Kelvin cost *far* less than those you would need to get all the way down to approaching absolute zero.

If Griffiths singularities can be studied and tailored across more materials, we may find superconductors that are within way more people’s reach. That could, in turn, massively change the study of [quantum computing](#) systems, which rely on superconductors and must be kept at these extremely low temperatures. Instead of a low temperature material with just one superconductive hot spot, we might use a higher temperature iron pnictide with well controlled Griffiths islands.

The researchers suggest that the next step could be to extend this research into copper-containing (cuprite) superconductors, which work at even higher [temperatures](#) than the iron pnictides. We’ll just have to wait and see what comes next.

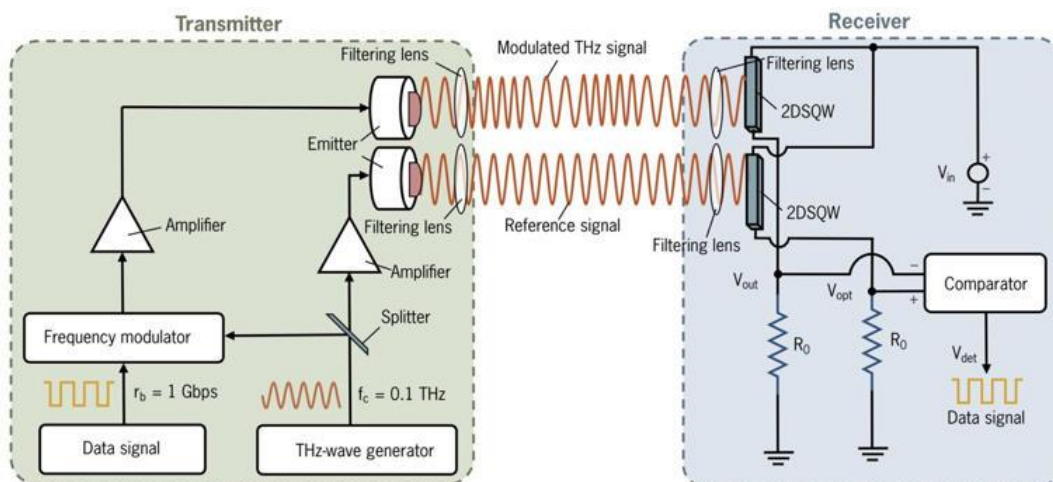

The block diagram of the Floquet-engineered dual-signaling wireless communication framework. At the transmitter end, the system generates both a modulated THz-range signal and a reference THz signal with a frequency matching that of the carrier signal. Meanwhile, the receiver is equipped with two 2DSQWs to detect both the modulated signal and the reference signal. Credit: Kosala Herath, Ampalavanapillai Nirmalathas, Sarath D. Gunapala and Malin Premaratne

As computing technology advances, we have shifted from using large, single-chip processors to systems made up of smaller, specialized chips called "chiplets." These chiplets work together to boost processing power and efficiency.

This transition is crucial because we've reached the physical limits of how many transistors can fit on a single chip. As transistors shrink, problems such as overheating and power inefficiency become more severe.^[1] Using multiple chiplets in one system can increase computing power without facing these physical constraints.

The challenge of communication between chiplets

Traditionally, communication within a chip has been managed by a system called Network-on-Chip (NoC), which acts like a data highway. This method becomes inefficient as systems get more complex, especially with multiple chiplets. Data has to travel farther across more grid points, slowing communication and increasing energy consumption.

When we scale this approach to various chiplets, we create what's known as Network-in-Package (NiP). However, the same issues—delays, energy inefficiency, and limited scalability—still exist as wired connections dominate data transfer.

To solve these problems, researchers are exploring wireless communication at the chip level. Instead of relying on wires, chiplets could communicate wirelessly using tiny antennas.

Terahertz (THz) frequencies, electromagnetic waves between infrared and microwave, offer high-speed data transfer, making them ideal for this application. However, THz signals are highly noise-sensitive, disrupting communication and making it harder to decode transmitted data.

Floquet engineering: Improving signal detection

Our research addresses this issue with Floquet engineering, a technique from quantum physics that helps control electron behavior in a material when exposed to high-frequency signals.^[2,3,4] This technique makes the system more responsive to certain frequencies, improving the detection and decoding of THz wireless signals, even in noisy conditions.

We applied this method to a two-dimensional semiconductor quantum well (2DSQW)—a very thin layer of semiconductor material that restricts electron movement to two dimensions. This setup enhances the system's ability to detect THz signals, even when noise interference is high. Our research is [published](#) in the *IEEE Journal on Selected Areas in Communications*.

Dual-signaling architecture for more accurate communication

To further improve noise handling, we developed a dual-signaling architecture, where two receivers work together to monitor signals. This setup allows the system to adjust a key parameter, called reference voltage, based on the noise levels detected. This real-time adjustment significantly improves signal decoding accuracy.

Our simulations showed that this dual-signaling system reduces error rates compared to traditional single-receiver systems, ensuring reliable communication in noisy environments—a critical requirement for chip-scale wireless communication.

By overcoming the challenges of noise and signal degradation, our dual-signaling technique marks a key advancement in developing high-speed, noise-resistant wireless communication for chiplets. This innovation brings us closer to creating more efficient, scalable, and adaptable computing systems for the technologies of tomorrow.

This story is part of [Science X Dialog](#), where researchers can report findings from their published research articles. [Visit this page](#) for information about Science X Dialog and how to participate.

More information: Kosala Herath et al, A Dual-Signaling Architecture for Enhancing Noise Resilience in Floquet Engineering-Based Chip-Scale Wireless Communication, *IEEE Journal on Selected Areas in Communications* (2024). [DOI: 10.1109/JSAC.2024.3399206](https://doi.org/10.1109/JSAC.2024.3399206)

¹ Malin Premaratne and Govind P. Agrawal, Theoretical foundations of nanoscale quantum devices, Cambridge University Press (2021). [DOI: 10.1017/9781108634472](https://doi.org/10.1017/9781108634472)

² Kosala Herath et al, Generalized model for the charge transport properties of dressed quantum Hall systems, *Physical Review B* (2022). [DOI: 10.1103/PhysRevB.105.035430](https://doi.org/10.1103/PhysRevB.105.035430)

³ Kosala Herath et al, Floquet engineering of dressed surface plasmon polariton modes in plasmonic waveguides, *Physical Review B* (2022). [DOI: 10.1103/PhysRevB.106.235422](https://doi.org/10.1103/PhysRevB.106.235422)

⁴ Kosala Herath et al, A Floquet engineering approach to optimize Schottky junction-based surface plasmonic waveguides, *Scientific Reports* (2023). [DOI: 10.1038/s41598-023-37801-x](https://doi.org/10.1038/s41598-023-37801-x)

Bios:

Kosala Herath received the B.Sc. degree (Hons.) in electronic and telecommunication engineering from the University of Moratuwa, Sri Lanka, in 2018. He is currently pursuing the Ph.D. degree with the Department of Electrical and Computer System Engineering, Monash University, Australia. From 2018 to 2020, he was with WSO2 Inc. His research interests include nanoplasmonics, non-equilibrium many-body quantum systems, chip-scale wireless communication systems, and quantum computing.

Ampalavanapillai Nirmalathas received the Ph.D. degree in electrical and electronic engineering from The University of Melbourne. He is currently the Acting Dean with the Faculty of Engineering and Information Technology, the Lead of the Wireless Innovation Laboratory (WILAB), and a Professor of electrical and electronic engineering with The University of Melbourne. His current research interests include microwave photonics, optical-wireless network integration, broadband networks, photonic reservoir and edge computing, and scalability of

telecom and internet services. Since 2021, he has been the Chair of the IEEE Photonics Society's Future Technologies Task Force. From 2020 to 2021, he was the Co-Chair of the IEEE Future Networks Initiative's Optics Working Group. He is also the Deputy Co-Chair of the National Committee on Information and Communication Sciences of the Australia Academy of Sciences.

Sarath D. Gunapala received the Ph.D. degree in physics from the University of Pittsburgh, Pittsburgh, PA, USA, in 1986. Since then, he has studied infrared properties of III–V compound semiconductor heterostructures and the development of quantum well infrared photodetectors for infrared imaging at AT&T Bell Laboratories. In 1992, he joined NASA's Jet Propulsion Laboratory, California Institute of Technology, Pasadena, CA, USA, where he is currently the Director of the Center for Infrared Photodetectors. He is also a Senior Research Scientist and a Principal Member of the Engineering Staff with the NASA Jet Propulsion Laboratory. He has authored more than 300 publications, including several book chapters on infrared imaging focal plane arrays, and holds 26 patents.

Malin Premaratne earned several degrees from the University of Melbourne, including a B.Sc. in mathematics, a B.E. in electrical and electronics engineering (with first-class honors), and a PhD in 1995, 1995, and 1998, respectively. He has been leading the research program in high-performance computing applications to complex systems simulations at the Advanced Computing and Simulation Laboratory, Monash University, Clayton, since 2004. Currently, he serves as the Vice President of the Academic Board of Monash University and is a Full Professor. In addition to his work at Monash University, Professor Premaratne is also a Visiting Researcher at several prestigious institutions, including the Jet-Propulsion Laboratory at Caltech, the University of Melbourne, the Australian National University, the University of California Los Angeles, the University of Rochester New York, and Oxford University. He has published more than 250 journal papers and two books and has served as an associate editor for several leading academic journals, including *IEEE Photonics Technology Letters*, *IEEE Photonics Journal* and *Advances in Optics and Photonics*. Professor Premaratne's contributions to the field of optics and photonics have been recognized with numerous fellowships, including the Fellow of the Optical Society of America (FOSA), the Society of Photo-Optical Instrumentation Engineers USA (FSPIE), the Institute of Physics U.K. (FInstP), the Institution of Engineering and Technology U.K. (FIET) and The Institute of Engineers Australia (FIEAust).

- [Donate](#)
- [Create account](#)
- [Log in](#)

Personal tools

-
-

Contents

hide

- [\(Top\)](#)
- [History](#)
Toggle History subsection
- [Principles](#)
Toggle Principles subsection
- [Mathematical rigor](#)
- [See also](#)
- [References](#)
- [Further reading](#)
- [External links](#)

Quantum field theory

64 languages

- [Article](#)
- [Talk](#)
- [Read](#)
- [Edit](#)
- [View history](#)

Tools

-

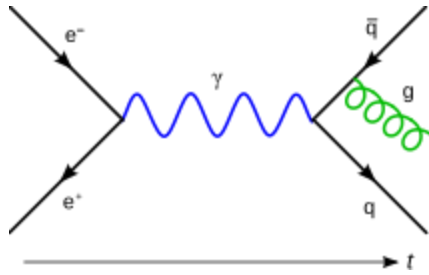

[Feynman diagram](#)

[History](#)

show

Background

show

[Symmetries](#)

show

Tools

show

Equations

show

[Standard Model](#)

show

Incomplete theories

show

Scientists

- [v](#)
- [t](#)
- [e](#)

In [theoretical physics](#), **quantum field theory (QFT)** is a theoretical framework that combines [classical field theory](#), [special relativity](#), and [quantum mechanics](#).^{[1]:xi} QFT is used in [particle physics](#) to construct [physical models](#) of [subatomic particles](#) and in [condensed matter physics](#) to construct models of [quasiparticles](#). The current [standard model of particle physics](#) is based on quantum field theory.

History

[\[edit\]](#)

Main article: [History of quantum field theory](#)

Quantum field theory emerged from the work of generations of theoretical physicists spanning much of the 20th century. Its development began in the 1920s with the description of interactions between [light](#) and [electrons](#), culminating in the first quantum field theory—[quantum electrodynamics](#). A major theoretical obstacle soon followed with the appearance and persistence of various infinities in perturbative calculations, a problem only resolved in the 1950s with the invention of the [renormalization](#) procedure. A second major barrier came with QFT's apparent inability to describe the [weak](#) and [strong interactions](#), to the point where some theorists called for the abandonment of the field theoretic approach. The development of [gauge theory](#) and the completion of the [Standard Model](#) in the 1970s led to a renaissance of quantum field theory.

Theoretical background

[\[edit\]](#)

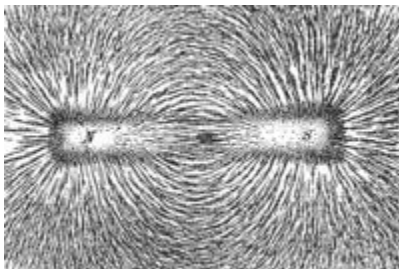

[Magnetic field lines](#) visualized using [iron filings](#). When a piece of paper is sprinkled with iron filings and placed above a bar magnet, the filings align according to the direction of the magnetic field, forming arcs allowing viewers to clearly see the poles of the magnet and to see the magnetic field generated.

Quantum field theory results from the combination of [classical field theory](#), [quantum mechanics](#), and [special relativity](#).^{[1]:xi} A brief overview of these theoretical precursors follows.

The earliest successful classical field theory is one that emerged from [Newton's law of universal gravitation](#), despite the complete absence of the concept of fields from his 1687 treatise *Philosophiæ Naturalis Principia Mathematica*. The force of gravity as described by Isaac Newton is an "[action at a distance](#)"—its effects on faraway objects are instantaneous, no matter the distance. In an exchange of letters with [Richard Bentley](#), however, Newton stated that "it is inconceivable that inanimate brute matter should, without the mediation of something else which is not material, operate upon and affect other matter without mutual contact".^{[2]:4} It was not until the 18th century that mathematical physicists discovered a convenient description of gravity based on fields—a numerical quantity (a [vector](#) in the case of [gravitational field](#)) assigned to every point in space indicating the action of gravity on any particle at that point. However, this was considered merely a mathematical trick.^{[3]:18}

Fields began to take on an existence of their own with the development of [electromagnetism](#) in the 19th century. [Michael Faraday](#) coined the English term "field" in 1845. He introduced fields as properties of space (even when it is devoid of matter) having physical effects. He argued against "action at a distance", and proposed that interactions between objects occur via space-filling "lines of force". This description of fields remains to this day.^{[2][4]:301[5]:2}

The theory of [classical electromagnetism](#) was completed in 1864 with [Maxwell's equations](#), which described the relationship between the [electric field](#), the [magnetic field](#), [electric current](#), and [electric charge](#). Maxwell's equations implied the existence of [electromagnetic waves](#), a phenomenon whereby electric and magnetic fields propagate from one spatial point to another at a finite speed, which turns out to be the [speed of light](#). Action-at-a-distance was thus conclusively refuted.^{[2]:19}

Despite the enormous success of classical electromagnetism, it was unable to account for the discrete lines in [atomic spectra](#), nor for the distribution of [blackbody radiation](#) in different wavelengths.^[6] [Max Planck](#)'s study of blackbody radiation marked the beginning of quantum mechanics. He treated atoms, which absorb and emit [electromagnetic radiation](#), as tiny [oscillators](#) with the crucial property that their energies can only take on a series of discrete, rather than continuous, values. These are known as [quantum harmonic oscillators](#). This process of restricting energies to discrete values is called quantization.^{[7]:Ch.2} Building on this idea, [Albert Einstein](#) proposed in 1905 an explanation for the [photoelectric effect](#), that light is composed of individual packets of energy called [photons](#) (the quanta of light). This implied that the electromagnetic radiation, while being waves in the classical electromagnetic field, also exists in the form of particles.^[6]

In 1913, [Niels Bohr](#) introduced the [Bohr model](#) of atomic structure, wherein [electrons](#) within atoms can only take on a series of discrete, rather than continuous, energies. This is another example of quantization. The Bohr model

successfully explained the discrete nature of atomic spectral lines. In 1924, [Louis de Broglie](#) proposed the hypothesis of [wave–particle duality](#), that microscopic particles exhibit both wave-like and particle-like properties under different circumstances.^[6] Uniting these scattered ideas, a coherent discipline, [quantum mechanics](#), was formulated between 1925 and 1926, with important contributions from [Max Planck](#), [Louis de Broglie](#), [Werner Heisenberg](#), [Max Born](#), [Erwin Schrödinger](#), [Paul Dirac](#), and [Wolfgang Pauli](#).^{[3]:22–23}

In the same year as his paper on the photoelectric effect, Einstein published his theory of [special relativity](#), built on Maxwell's electromagnetism. New rules, called [Lorentz transformations](#), were given for the way time and space coordinates of an event change under changes in the observer's velocity, and the distinction between time and space was blurred.^{[3]:19} It was proposed that all physical laws must be the same for observers at different velocities, i.e. that physical laws be invariant under Lorentz transformations.

Two difficulties remained. Observationally, the [Schrödinger equation](#) underlying quantum mechanics could explain the [stimulated emission](#) of radiation from atoms, where an electron emits a new photon under the action of an external electromagnetic field, but it was unable to explain [spontaneous emission](#), where an electron spontaneously decreases in energy and emits a photon even without the action of an external electromagnetic field. Theoretically, the Schrödinger equation could not describe photons and was inconsistent with the principles of special relativity—it treats time as an ordinary number while promoting spatial coordinates to [linear operators](#).^[6]

Quantum electrodynamics

[\[edit\]](#)

Quantum field theory naturally began with the study of electromagnetic interactions, as the electromagnetic field was the only known classical field as of the 1920s.^{[8]:1}

Through the works of Born, Heisenberg, and [Pascual Jordan](#) in 1925–1926, a quantum theory of the free electromagnetic field (one with no interactions with matter) was developed via [canonical quantization](#) by treating the electromagnetic field as a set of [quantum harmonic oscillators](#).^{[8]:1} With the exclusion of interactions, however, such a theory was yet incapable of making quantitative predictions about the real world.^{[3]:22}

In his seminal 1927 paper *The quantum theory of the emission and absorption of radiation*, Dirac coined the term [quantum electrodynamics](#) (QED), a theory that adds upon the terms describing the free electromagnetic field an additional interaction term between electric [current density](#) and the [electromagnetic vector potential](#). Using first-order [perturbation theory](#), he successfully explained the phenomenon of spontaneous emission. According to the [uncertainty principle](#) in quantum mechanics, quantum harmonic oscillators cannot remain stationary, but they have a non-zero minimum energy and must always be oscillating, even in the lowest energy state (the [ground state](#)). Therefore, even in a perfect [vacuum](#), there remains an oscillating electromagnetic field having [zero-point energy](#). It is this [quantum fluctuation](#) of electromagnetic fields in the vacuum that "stimulates" the spontaneous emission of

radiation by electrons in atoms. Dirac's theory was hugely successful in explaining both the emission and absorption of radiation by atoms; by applying second-order perturbation theory, it was able to account for the [scattering](#) of photons, [resonance fluorescence](#) and non-relativistic [Compton scattering](#). Nonetheless, the application of higher-order perturbation theory was plagued with problematic infinities in calculations.^{[6]:71}

In 1928, Dirac wrote down a [wave equation](#) that described relativistic electrons: the [Dirac equation](#). It had the following important consequences: the [spin](#) of an electron is 1/2; the electron [g-factor](#) is 2; it led to the correct Sommerfeld formula for the [fine structure](#) of the [hydrogen atom](#); and it could be used to derive the [Klein–Nishina formula](#) for relativistic Compton scattering. Although the results were fruitful, the theory also apparently implied the existence of negative energy states, which would cause atoms to be unstable, since they could always decay to lower energy states by the emission of radiation.^{[6]:71–72}

The prevailing view at the time was that the world was composed of two very different ingredients: material particles (such as electrons) and [quantum fields](#) (such as photons). Material particles were considered to be eternal, with their physical state described by the probabilities of finding each particle in any given region of space or range of velocities. On the other hand, photons were considered merely the [excited states](#) of the underlying quantized electromagnetic field, and could be freely created or destroyed. It was between 1928 and 1930 that Jordan, [Eugene Wigner](#), Heisenberg, Pauli, and [Enrico Fermi](#) discovered that material particles could also be seen as excited states of quantum fields. Just as photons are excited states of the quantized electromagnetic field, so each type of particle had its corresponding quantum field: an electron field, a proton field, etc. Given enough energy, it would now be possible to create material particles. Building on this idea, Fermi proposed in 1932 an explanation for [beta decay](#) known as [Fermi's interaction](#). [Atomic nuclei](#) do not contain electrons *per se*, but in the process of decay, an electron is created out of the surrounding electron field, analogous to the photon created from the surrounding electromagnetic field in the radiative decay of an excited atom.^{[3]:22–23}

It was realized in 1929 by Dirac and others that negative energy states implied by the Dirac equation could be removed by assuming the existence of particles with the same mass as electrons but opposite electric charge. This not only ensured the stability of atoms, but it was also the first proposal of the existence of [antimatter](#). Indeed, the evidence for [positrons](#) was discovered in 1932 by [Carl David Anderson](#) in [cosmic rays](#). With enough energy, such as by absorbing a photon, an electron-positron pair could be created, a process called [pair production](#); the reverse process, annihilation, could also occur with the emission of a photon. This showed that particle numbers need not be fixed during an interaction. Historically, however, positrons were at first thought of as "holes" in an infinite electron sea, rather than a new kind of particle, and this theory was referred to as the [Dirac hole theory](#).^{[6]:72}^{[3]:23} QFT naturally incorporated antiparticles in its formalism.^{[3]:24}

Infinities and renormalization

[\[edit\]](#)

[Robert Oppenheimer](#) showed in 1930 that higher-order perturbative calculations in QED always resulted in infinite quantities, such as the electron [self-energy](#) and the vacuum zero-point energy of the electron and photon fields,^[6] suggesting that the computational methods at the time could not properly deal with interactions involving photons with extremely high momenta.^{[3]:25} It was not until 20 years later that a systematic approach to remove such infinities was developed.

A series of papers was published between 1934 and 1938 by [Ernst Stueckelberg](#) that established a relativistically invariant formulation of QFT. In 1947, Stueckelberg also independently developed a complete renormalization procedure. Such achievements were not understood and recognized by the theoretical community.^[6]

Faced with these infinities, [John Archibald Wheeler](#) and Heisenberg proposed, in 1937 and 1943 respectively, to supplant the problematic QFT with the so-called [S-matrix theory](#). Since the specific details of microscopic interactions are inaccessible to observations, the theory should only attempt to describe the relationships between a small number of [observables](#) (e.g. the energy of an atom) in an interaction, rather than be concerned with the microscopic minutiae of the interaction. In 1945, [Richard Feynman](#) and Wheeler daringly suggested abandoning QFT altogether and proposed [action-at-a-distance](#) as the mechanism of particle interactions.^{[3]:26}

In 1947, [Willis Lamb](#) and [Robert Retherford](#) measured the minute difference in the $^2S_{1/2}$ and $^2P_{1/2}$ energy levels of the hydrogen atom, also called the [Lamb shift](#). By ignoring the contribution of photons whose energy exceeds the electron mass, [Hans Bethe](#) successfully estimated the numerical value of the Lamb shift.^{[6][3]:28} Subsequently, [Norman Myles Kroll](#), Lamb, [James Bruce French](#), and [Victor Weisskopf](#) again confirmed this value using an approach in which infinities cancelled other infinities to result in finite quantities. However, this method was clumsy and unreliable and could not be generalized to other calculations.^[6]

The breakthrough eventually came around 1950 when a more robust method for eliminating infinities was developed by [Julian Schwinger](#), [Richard Feynman](#), [Freeman Dyson](#), and [Shinichiro Tomonaga](#). The main idea is to replace the calculated values of mass and charge, infinite though they may be, by their finite measured values. This systematic computational procedure is known as [renormalization](#) and can be applied to arbitrary order in perturbation theory.^[6] As Tomonaga said in his Nobel lecture:

Since those parts of the modified mass and charge due to field reactions [become infinite], it is impossible to calculate them by the theory. However, the mass and charge observed in experiments are not the original mass and charge but the mass and charge as modified by field reactions, and they are finite. On the other hand, the mass and charge appearing in the theory are... the values modified by field reactions. Since this is so, and particularly since the theory is unable to calculate the modified mass and charge, we may adopt the procedure of substituting experimental values for them phenomenologically... This procedure is called the renormalization of mass and

charge... After long, laborious calculations, less skillful than Schwinger's, we obtained a result... which was in agreement with [the] Americans'.^[9]

By applying the renormalization procedure, calculations were finally made to explain the electron's [anomalous magnetic moment](#) (the deviation of the electron [g-factor](#) from 2) and [vacuum polarization](#). These results agreed with experimental measurements to a remarkable degree, thus marking the end of a "war against infinities".^[6]

At the same time, Feynman introduced the [path integral formulation](#) of quantum mechanics and [Feynman diagrams](#).^{[8]:2} The latter can be used to visually and intuitively organize and to help compute terms in the perturbative expansion. Each diagram can be interpreted as paths of particles in an interaction, with each vertex and line having a corresponding mathematical expression, and the product of these expressions gives the [scattering amplitude](#) of the interaction represented by the diagram.^{[1]:5}

It was with the invention of the renormalization procedure and Feynman diagrams that QFT finally arose as a complete theoretical framework.^{[8]:2}

Non-renormalizability

[\[edit\]](#)

Given the tremendous success of QED, many theorists believed, in the few years after 1949, that QFT could soon provide an understanding of all microscopic phenomena, not only the interactions between photons, electrons, and positrons. Contrary to this optimism, QFT entered yet another period of depression that lasted for almost two decades.^{[3]:30}

The first obstacle was the limited applicability of the renormalization procedure. In perturbative calculations in QED, all infinite quantities could be eliminated by redefining a small (finite) number of physical quantities (namely the mass and charge of the electron). Dyson proved in 1949 that this is only possible for a small class of theories called "renormalizable theories", of which QED is an example. However, most theories, including the [Fermi theory](#) of the [weak interaction](#), are "non-renormalizable". Any perturbative calculation in these theories beyond the first order would result in infinities that could not be removed by redefining a finite number of physical quantities.^{[3]:30}

The second major problem stemmed from the limited validity of the Feynman diagram method, which is based on a series expansion in perturbation theory. In order for the series to converge and low-order calculations to be a good approximation, the [coupling constant](#), in which the series is expanded, must be a sufficiently small number. The coupling constant in QED is the [fine-structure constant](#) $\alpha \approx 1/137$, which is small enough that only the simplest, lowest order, Feynman diagrams need to be considered in realistic calculations. In contrast, the coupling constant in the [strong interaction](#) is roughly of the order of one, making complicated, higher order, Feynman diagrams just as important as simple ones. There was thus no way of deriving reliable quantitative predictions for the strong interaction using perturbative QFT methods.^{[3]:31}

With these difficulties looming, many theorists began to turn away from QFT. Some focused on [symmetry](#) principles and [conservation laws](#), while others picked up the old S-matrix theory of Wheeler and Heisenberg. QFT was used heuristically as guiding principles, but not as a basis for quantitative calculations.^{[3]:31}

Source theory

[\[edit\]](#)

Schwinger, however, took a different route. For more than a decade he and his students had been nearly the only exponents of field theory,^{[10]:454} but in 1951^{[11][12]} he found a way around the problem of the infinities with a new method using *external sources* as currents coupled to gauge fields.^[13] Motivated by the former findings, Schwinger kept pursuing this approach in order to "quantumly" generalize the [classical process](#) of coupling external forces to the configuration space parameters known as Lagrange multipliers. He summarized his [source theory](#) in 1966^[14] then expanded the theory's applications to quantum electrodynamics in his three volume-set titled: *Particles, Sources, and Fields*.^{[15][16][17]} Developments in pion physics, in which the new viewpoint was most successfully applied, convinced him of the great advantages of mathematical simplicity and conceptual clarity that its use bestowed.^[15]

In source theory there are no divergences, and no renormalization. It may be regarded as the calculational tool of field theory, but it is more general.^[18] Using source theory, Schwinger was able to calculate the anomalous magnetic moment of the electron, which he had done in 1947, but this time with no 'distracting remarks' about infinite quantities.^{[10]:467}

Schwinger also applied source theory to his QFT theory of gravity, and was able to reproduce all four of Einstein's classic results: gravitational red shift, deflection and slowing of light by gravity, and the perihelion precession of Mercury.^[19] The neglect of source theory by the physics community was a major disappointment for Schwinger:

The lack of appreciation of these facts by others was depressing, but understandable. - J. Schwinger^[15]

See "[the shoes incident](#)" between J. Schwinger and [S. Weinberg](#).^[10]

Standard model

[\[edit\]](#)

[Elementary particles](#) of the [Standard Model](#): six types of [quarks](#), six types of [leptons](#), four types of [gauge bosons](#) that carry [fundamental interactions](#), as well as the [Higgs boson](#), which endow elementary particles with mass.

In 1954, [Yang Chen-Ning](#) and [Robert Mills](#) generalized the [local symmetry](#) of QED, leading to [non-Abelian gauge theories](#) (also known as Yang–Mills theories), which are based on more complicated local [symmetry groups](#).^{[20]:5} In QED, (electrically) charged particles interact via the exchange of photons, while in non-Abelian gauge theory, particles carrying a new type of "[charge](#)" interact via the exchange of massless [gauge bosons](#). Unlike photons, these gauge bosons themselves carry charge.^{[3]:32[21]}

[Sheldon Glashow](#) developed a non-Abelian gauge theory that unified the electromagnetic and weak interactions in 1960. In 1964, [Abdus Salam](#) and [John Clive Ward](#) arrived at the same theory through a different path. This theory, nevertheless, was non-renormalizable.^[22]

[Peter Higgs](#), [Robert Brout](#), [François Englert](#), [Gerald Guralnik](#), [Carl Hagen](#), and [Tom Kibble](#) proposed in their famous *[Physical Review Letters papers](#)* that the gauge symmetry in Yang–Mills theories could be broken by a mechanism called [spontaneous symmetry breaking](#), through which originally massless gauge bosons could acquire mass.^{[20]:5–6}

By combining the earlier theory of Glashow, Salam, and Ward with the idea of spontaneous symmetry breaking, [Steven Weinberg](#) wrote down in 1967 a theory describing [electroweak interactions](#) between all [leptons](#) and the effects of the [Higgs boson](#). His theory was at first mostly ignored,^{[22][20]:6} until it was brought back to light in 1971 by [Gerard 't Hooft](#)'s proof that non-Abelian gauge theories are renormalizable. The electroweak theory of Weinberg and Salam was extended from leptons to [quarks](#) in 1970 by Glashow, [John Iliopoulos](#), and [Luciano Maiani](#), marking its completion.^[22]

[Harald Fritzsch](#), [Murray Gell-Mann](#), and [Heinrich Leutwyler](#) discovered in 1971 that certain phenomena involving the [strong interaction](#) could also be explained by non-Abelian gauge theory. [Quantum chromodynamics](#) (QCD) was born. In 1973, [David Gross](#), [Frank Wilczek](#), and [Hugh David Politzer](#) showed that non-Abelian gauge theories are "[asymptotically free](#)", meaning that under renormalization, the coupling constant of the strong interaction decreases as the interaction energy increases. (Similar discoveries had been made numerous times previously, but they had been largely ignored.)^{[20]:11} Therefore, at least in high-energy interactions, the coupling constant in QCD becomes sufficiently small to warrant a perturbative series expansion, making quantitative predictions for the strong interaction possible.^{[3]:32}

These theoretical breakthroughs brought about a renaissance in QFT. The full theory, which includes the electroweak theory and chromodynamics, is referred to today as the [Standard Model](#) of elementary particles.^[23] The Standard Model successfully describes all [fundamental interactions](#) except [gravity](#), and its many predictions have been met with remarkable experimental confirmation in subsequent decades.^{[8]:3} The [Higgs boson](#), central to the mechanism of spontaneous symmetry breaking, was finally detected in 2012 at [CERN](#), marking the complete verification of the existence of all constituents of the Standard Model.^[24]

Other developments

[\[edit\]](#)

The 1970s saw the development of non-perturbative methods in non-Abelian gauge theories. The ['t Hooft–Polyakov monopole](#) was discovered theoretically by 't Hooft and [Alexander Polyakov](#), [flux tubes](#) by [Holger Bech Nielsen](#) and [Poul Olesen](#), and [instantons](#) by Polyakov and coauthors. These objects are inaccessible through perturbation theory.^{[8]:4}

[Supersymmetry](#) also appeared in the same period. The first supersymmetric QFT in four dimensions was built by [Yuri Golfand](#) and [Evgeny Likhtman](#) in 1970, but their result failed to garner widespread interest due to the [Iron Curtain](#). Supersymmetry only took off in the theoretical community after the work of [Julius Wess](#) and [Bruno Zumino](#) in 1973.^{[8]:7}

Among the four fundamental interactions, gravity remains the only one that lacks a consistent QFT description. Various attempts at a theory of [quantum gravity](#) led to the development of [string theory](#),^{[8]:6} itself a type of two-dimensional QFT with [conformal symmetry](#).^[25] [Joël Scherk](#) and [John Schwarz](#) first proposed in 1974 that string theory could be *the* quantum theory of gravity.^[26]

Condensed-matter-physics

[\[edit\]](#)

Although quantum field theory arose from the study of interactions between elementary particles, it has been successfully applied to other physical systems, particularly to [many-body systems](#) in [condensed matter physics](#).

Historically, the Higgs mechanism of spontaneous symmetry breaking was a result of [Yoichiro Nambu](#)'s application of [superconductor](#) theory to elementary particles, while the concept of renormalization came out of the study of second-order [phase transitions](#) in matter.^[27]

Soon after the introduction of photons, Einstein performed the quantization procedure on vibrations in a crystal, leading to the first [quasiparticle](#)—[phonons](#). Lev Landau claimed that low-energy excitations in many condensed matter systems could be described in terms of interactions between a set of quasiparticles. The Feynman diagram method of QFT was naturally well suited to the analysis of various phenomena in condensed matter systems.^[28]

Gauge theory is used to describe the quantization of [magnetic flux](#) in superconductors, the [resistivity](#) in the [quantum Hall effect](#), as well as the relation between frequency and voltage in the AC [Josephson effect](#).^[28]

Principles

[\[edit\]](#)

For simplicity, [natural units](#) are used in the following sections, in which the [reduced Planck constant](#) \hbar and the [speed of light](#) c are both set to one.

Classical fields

See also: [Classical field theory](#)

A classical [field](#) is a [function](#) of spatial and time coordinates.^[29] Examples include the [gravitational field](#) in [Newtonian gravity](#) $\mathbf{g}(\mathbf{x}, t)$ and the [electric field](#) $\mathbf{E}(\mathbf{x}, t)$ and [magnetic field](#) $\mathbf{B}(\mathbf{x}, t)$ in [classical electromagnetism](#). A classical field

can be thought of as a numerical quantity assigned to every point in space that changes in time. Hence, it has infinitely many [degrees of freedom](#).^{[29][30]}

Many phenomena exhibiting quantum mechanical properties cannot be explained by classical fields alone. Phenomena such as the [photoelectric effect](#) are best explained by discrete particles ([photons](#)), rather than a spatially continuous field. The goal of quantum field theory is to describe various quantum mechanical phenomena using a modified concept of fields.

[Canonical quantization](#) and [path integrals](#) are two common formulations of QFT.^{[31]:61} To motivate the fundamentals of QFT, an overview of classical field theory follows.

The simplest classical field is a real [scalar field](#) — a [real number](#) at every point in space that changes in time. It is denoted as $\phi(\mathbf{x}, t)$, where \mathbf{x} is the position vector, and t is the time. Suppose the [Lagrangian](#) of the field, L , is

$$L = \int d^3x \mathcal{L} = \int d^3x \left[\frac{1}{2} \dot{\phi}^2 - \frac{1}{2} (\nabla\phi)^2 - \frac{1}{2} m^2 \phi^2 \right],$$

where \mathcal{L} is the Lagrangian density, $\dot{\phi}$ is the time-derivative of the field, ∇ is the gradient operator, and m is a real parameter (the "mass" of the field). Applying the [Euler–Lagrange equation](#) on the Lagrangian:^{[1]:16}

$$\frac{\partial}{\partial t} \left[\frac{\partial \mathcal{L}}{\partial(\partial\phi/\partial t)} \right] + \sum_{i=1}^3 \frac{\partial}{\partial x^i} \left[\frac{\partial \mathcal{L}}{\partial(\partial\phi/\partial x^i)} \right] - \frac{\partial \mathcal{L}}{\partial \phi} = 0,$$

we obtain the [equations of motion](#) for the field, which describe the way it varies in time and space:

$$\left(\frac{\partial^2}{\partial t^2} - \nabla^2 + m^2 \right) \phi = 0.$$

This is known as the [Klein–Gordon equation](#).^{[1]:17}

The Klein–Gordon equation is a [wave equation](#), so its solutions can be expressed as a sum of [normal modes](#) (obtained via [Fourier transform](#)) as follows:

$$\phi(\mathbf{x}, t) = \int \frac{d^3p}{(2\pi)^3} \frac{1}{\sqrt{2\omega_{\mathbf{p}}}} \left(a_{\mathbf{p}} e^{-i\omega_{\mathbf{p}}t + i\mathbf{p}\cdot\mathbf{x}} + a_{\mathbf{p}}^* e^{i\omega_{\mathbf{p}}t - i\mathbf{p}\cdot\mathbf{x}} \right),$$

where a is a **complex number** (normalized by convention), $*$ denotes **complex conjugation**, and $\omega_{\mathbf{p}}$ is the frequency of the normal mode:

$$\omega_{\mathbf{p}} = \sqrt{|\mathbf{p}|^2 + m^2}.$$

Thus each normal mode corresponding to a single \mathbf{p} can be seen as a classical **harmonic oscillator** with frequency $\omega_{\mathbf{p}}$.^{[1]:21,26}

Canonical quantization [edit]

Main article: Canonical quantization

The quantization procedure for the above classical field to a quantum operator field is analogous to the promotion of a classical harmonic oscillator to a **quantum harmonic oscillator**.

The displacement of a classical harmonic oscillator is described by

$$x(t) = \frac{1}{\sqrt{2\omega}} a e^{-i\omega t} + \frac{1}{\sqrt{2\omega}} a^* e^{i\omega t},$$

where a is a complex number (normalized by convention), and ω is the oscillator's frequency. Note that x is the displacement of a particle in simple harmonic motion from the equilibrium position, not to be confused with the spatial label \mathbf{x} of a quantum field.

For a quantum harmonic oscillator, $x(t)$ is promoted to a **linear operator** $\hat{x}(t)$:

$$\hat{x}(t) = \frac{1}{\sqrt{2\omega}} \hat{a} e^{-i\omega t} + \frac{1}{\sqrt{2\omega}} \hat{a}^\dagger e^{i\omega t}.$$

Complex numbers a and a^* are replaced by the **annihilation operator** \hat{a} and the **creation operator** \hat{a}^\dagger , respectively, where \dagger denotes

Complex numbers a and a^* are replaced by the **annihilation operator** \hat{a} and the **creation operator** \hat{a}^\dagger , respectively, where \dagger denotes **Hermitian conjugation**. The **commutation relation** between the two is

$$[\hat{a}, \hat{a}^\dagger] = 1.$$

The **Hamiltonian** of the simple harmonic oscillator can be written as

$$\hat{H} = \hbar\omega \hat{a}^\dagger \hat{a} + \frac{1}{2} \hbar\omega.$$

The **vacuum state** $|0\rangle$, which is the lowest energy state, is defined by

$$\hat{a}|0\rangle = 0$$

and has energy $\frac{1}{2} \hbar\omega$. One can easily check that $[\hat{H}, \hat{a}^\dagger] = \hbar\omega \hat{a}^\dagger$, which implies that \hat{a}^\dagger increases the energy of the simple harmonic oscillator by $\hbar\omega$. For example, the state $\hat{a}^\dagger|0\rangle$ is an eigenstate of energy $3\hbar\omega/2$. Any energy eigenstate state of a single harmonic oscillator can be obtained from $|0\rangle$ by successively applying the creation operator \hat{a}^\dagger .^{[1]:20} and any state of the system can be expressed as a linear combination of the states

$$|n\rangle \propto (\hat{a}^\dagger)^n |0\rangle.$$

A similar procedure can be applied to the real scalar field ϕ , by promoting it to a quantum field operator $\hat{\phi}$, while the annihilation operator $\hat{a}_{\mathbf{p}}$, the creation operator $\hat{a}_{\mathbf{p}}^\dagger$ and the angular frequency $\omega_{\mathbf{p}}$ are now for a particular \mathbf{p} :

$$\hat{\phi}(\mathbf{x}, t) = \int \frac{d^3 p}{(2\pi)^3} \frac{1}{\sqrt{2\omega_{\mathbf{p}}}} \left(\hat{a}_{\mathbf{p}} e^{-i\omega_{\mathbf{p}} t + i\mathbf{p}\cdot\mathbf{x}} + \hat{a}_{\mathbf{p}}^\dagger e^{i\omega_{\mathbf{p}} t - i\mathbf{p}\cdot\mathbf{x}} \right).$$

Their commutation relations are:^{[1]:21}

$$[\hat{a}_{\mathbf{p}}, \hat{a}_{\mathbf{q}}^\dagger] = (2\pi)^3 \delta(\mathbf{p} - \mathbf{q}), \quad [\hat{a}_{\mathbf{p}}, \hat{a}_{\mathbf{q}}] = [\hat{a}_{\mathbf{p}}^\dagger, \hat{a}_{\mathbf{q}}^\dagger] = 0,$$

where δ is the [Dirac delta function](#). The vacuum state $|0\rangle$ is defined by

$$\hat{a}_{\mathbf{p}}|0\rangle = 0, \quad \text{for all } \mathbf{p}.$$

Any quantum state of the field can be obtained from $|0\rangle$ by successively applying creation operators $\hat{a}_{\mathbf{p}}^\dagger$ (or by a linear combination of such states), e.g. ^{[1]:22}

$$\left(\hat{a}_{\mathbf{p}_3}^\dagger\right)^3 \hat{a}_{\mathbf{p}_2}^\dagger \left(\hat{a}_{\mathbf{p}_1}^\dagger\right)^2 |0\rangle.$$

While the state space of a single quantum harmonic oscillator contains all the discrete energy states of one oscillating particle, the state space of a quantum field contains the discrete energy levels of an arbitrary number of particles. The latter space is known as a [Fock space](#), which can account for the fact that particle numbers are not fixed in relativistic quantum systems.^[32] The process of quantizing an arbitrary number of particles instead of a single particle is often also called [second quantization](#).^{[1]:19}

The foregoing procedure is a direct application of non-relativistic quantum mechanics and can be used to quantize (complex) scalar fields, [Dirac fields](#),^{[1]:52} [vector fields](#) (e.g. the electromagnetic field), and even [strings](#).^[33] However, creation and annihilation operators are only well defined in the simplest theories that contain no interactions (so-called free theory). In the case of the real scalar field, the existence of these operators was a consequence of the decomposition of solutions of the classical equations of motion into a sum of normal modes. To perform calculations on any realistic interacting theory, [perturbation theory](#) would be necessary.

The Lagrangian of any quantum field in nature would contain interaction terms in addition to the free theory terms. For example, a [quartic interaction](#) term could be introduced to the Lagrangian of the real scalar field:^{[1]:77}

$$\mathcal{L} = \frac{1}{2}(\partial_\mu \phi)(\partial^\mu \phi) - \frac{1}{2}m^2 \phi^2 - \frac{\lambda}{4!} \phi^4,$$

where μ is a spacetime index, $\partial_0 = \partial/\partial t$, $\partial_1 = \partial/\partial x^1$, etc. The summation over the index μ has been omitted following the [Einstein notation](#). If the parameter λ is sufficiently small, then the interacting theory described by the above Lagrangian can be considered as a small perturbation from the free theory.

Path integrals [edit]

Main article: [Path integral formulation](#)

The [path integral formulation](#) of QFT is concerned with the direct computation of the [scattering amplitude](#) of a certain interaction process, rather than the establishment of operators and state spaces. To calculate the [probability amplitude](#) for a system to evolve from some initial state $|\phi_I\rangle$ at time $t = 0$ to some final state $|\phi_F\rangle$ at $t = T$, the total time T is divided into N small intervals. The overall amplitude is the product of the amplitude of evolution within each interval, integrated over all intermediate states. Let H be the [Hamiltonian](#) (i.e. [generator of time evolution](#)), then^{[31]:10}

$$\langle \phi_F | e^{-iHT} | \phi_I \rangle = \int d\phi_1 \int d\phi_2 \cdots \int d\phi_{N-1} \langle \phi_F | e^{-iHT/N} | \phi_{N-1} \rangle \cdots \langle \phi_2 | e^{-iHT/N} | \phi_1 \rangle \langle \phi_1 | e^{-iHT/N} | \phi_I \rangle.$$

Taking the limit $N \rightarrow \infty$, the above product of integrals becomes the Feynman path integral:^{[1]:282[31]:12}

$$\langle \phi_F | e^{-iHT} | \phi_I \rangle = \int \mathcal{D}\phi(t) \exp\left\{i \int_0^T dt L\right\},$$

where L is the Lagrangian involving ϕ and its derivatives with respect to spatial and time coordinates, obtained from the Hamiltonian H via [Legendre transformation](#). The initial and final conditions of the path integral are respectively

$$\phi(0) = \phi_I, \quad \phi(T) = \phi_F.$$

In other words, the overall amplitude is the sum over the amplitude of every possible path between the initial and final states, where the amplitude of a path is given by the exponential in the integrand.

Two-point correlation function [edit]

Main article: *Correlation function (quantum field theory)*

In calculations, one often encounters expression like

$$\langle 0|T\{\phi(x)\phi(y)\}|0\rangle \quad \text{or} \quad \langle \Omega|T\{\phi(x)\phi(y)\}|\Omega\rangle$$

in the free or interacting theory, respectively. Here, x and y are position **four-vectors**, T is the **time ordering** operator that shuffles its operands so the time-components x^0 and y^0 increase from right to left, and $|0\rangle$ is the ground state (vacuum state) of the interacting theory, different from the free ground state $|0\rangle$. This expression represents the probability amplitude for the field to propagate from y to x , and goes by multiple names, like the two-point **propagator**, two-point **correlation function**, two-point **Green's function** or two-point function for short.^{[1]:82}

The free two-point function, also known as the **Feynman propagator**, can be found for the real scalar field by either canonical quantization or path integrals to be^{[1]:31,288[31]:23}

$$\langle 0|T\{\phi(x)\phi(y)\}|0\rangle \equiv D_F(x-y) = \lim_{\epsilon \rightarrow 0} \int \frac{d^4p}{(2\pi)^4} \frac{i}{p_\mu p^\mu - m^2 + i\epsilon} e^{-ip_\mu(x^\mu - y^\mu)}.$$

In an interacting theory, where the Lagrangian or Hamiltonian contains terms $L_I(t)$ or $H_I(t)$ that describe interactions, the two-point function is more difficult to define. However, through both the canonical quantization formulation and the path integral formulation, it is possible to express it through an infinite perturbation series of the *free* two-point function.

In canonical quantization, the two-point correlation function can be written as:^{[1]:87}

$$\langle \Omega|T\{\phi(x)\phi(y)\}|\Omega\rangle = \lim_{T \rightarrow \infty(1-i\epsilon)} \frac{\langle 0|T\{\phi_I(x)\phi_I(y) \exp[-i \int_{-T}^T dt H_I(t)]\}|0\rangle}{\langle 0|T\{\exp[-i \int_{-T}^T dt H_I(t)]\}|0\rangle},$$

where ϵ is an **infinitesimal** number and ϕ_I is the field operator under the free theory. Here, the **exponential** should be understood as its **power series** expansion. For example, in ϕ^4 -theory, the interacting term of the Hamiltonian is $H_I(t) = \int d^3x \frac{\lambda}{4!} \phi_I(x)^4$,^{[1]:84} and the expansion of the two-point correlator in terms of λ becomes

$$\langle \Omega|T\{\phi(x)\phi(y)\}|\Omega\rangle = \frac{\sum_{n=0}^{\infty} \frac{(-i\lambda)^n}{(4!)^n n!} \int d^4z_1 \cdots \int d^4z_n \langle 0|T\{\phi_I(x)\phi_I(y)\phi_I(z_1)^4 \cdots \phi_I(z_n)^4\}|0\rangle}{\sum_{n=0}^{\infty} \frac{(-i\lambda)^n}{(4!)^n n!} \int d^4z_1 \cdots \int d^4z_n \langle 0|T\{\phi_I(z_1)^4 \cdots \phi_I(z_n)^4\}|0\rangle}.$$

This perturbation expansion expresses the interacting two-point function in terms of quantities $\langle 0|\cdots|0\rangle$ that are evaluated in the *free* theory.

In the path integral formulation, the two-point correlation function can be written^{[1]:284}

$$\langle \Omega|T\{\phi(x)\phi(y)\}|\Omega\rangle = \lim_{T \rightarrow \infty(1-i\epsilon)} \frac{\int \mathcal{D}\phi \phi(x)\phi(y) \exp\left[i \int_{-T}^T d^4z \mathcal{L}\right]}{\int \mathcal{D}\phi \exp\left[i \int_{-T}^T d^4z \mathcal{L}\right]},$$

where \mathcal{L} is the Lagrangian density. As in the previous paragraph, the exponential can be expanded as a series in λ , reducing the interacting two-point function to quantities in the free theory.

Wick's theorem further reduce any n -point correlation function in the free theory to a sum of products of two-point correlation functions. For example,

$$\begin{aligned} \langle 0|T\{\phi(x_1)\phi(x_2)\phi(x_3)\phi(x_4)\}|0\rangle &= \langle 0|T\{\phi(x_1)\phi(x_2)\}|0\rangle \langle 0|T\{\phi(x_3)\phi(x_4)\}|0\rangle \\ &+ \langle 0|T\{\phi(x_1)\phi(x_3)\}|0\rangle \langle 0|T\{\phi(x_2)\phi(x_4)\}|0\rangle \end{aligned}$$

Since interacting correlation functions can be expressed in terms of free correlation functions, only the latter need to be evaluated in order to calculate all physical quantities in the (perturbative) interacting theory.^{[1]:90} This makes the Feynman propagator one of the most important quantities in quantum field theory.

Feynman diagram [edit]

Main article: Feynman diagram

Correlation functions in the interacting theory can be written as a perturbation series. Each term in the series is a product of Feynman propagators in the free theory and can be represented visually by a **Feynman diagram**. For example, the λ^1 term in the two-point correlation function in the ϕ^4 theory is

$$\frac{-i\lambda}{4!} \int d^4z \langle 0|T\{\phi(x)\phi(y)\phi(z)\phi(z)\phi(z)\phi(z)\}|0\rangle.$$

After applying Wick's theorem, one of the terms is

$$12 \cdot \frac{-i\lambda}{4!} \int d^4z D_F(x-z)D_F(y-z)D_F(z-z).$$

This term can instead be obtained from the Feynman diagram



The diagram consists of

- *external vertices* connected with one edge and represented by dots (here labeled x and y).
- *internal vertices* connected with four edges and represented by dots (here labeled z).
- *edges* connecting the vertices and represented by lines.

Every vertex corresponds to a single ϕ field factor at the corresponding point in spacetime, while the edges correspond to the propagators between the spacetime points. The term in the perturbation series corresponding to the diagram is obtained by writing down the expression that follows from the so-called Feynman rules:

1. For every internal vertex z_i , write down a factor $-i\lambda \int d^4z_i$.
2. For every edge that connects two vertices z_i and z_j , write down a factor $D_F(z_i - z_j)$.
3. Divide by the symmetry factor of the diagram.

With the symmetry factor 2, following these rules yields exactly the expression above. By Fourier transforming the propagator, the Feynman rules can be reformulated from position space into momentum space.^{[1]:91–94}

In order to compute the n -point correlation function to the k -th order, list all valid Feynman diagrams with n external points and k or fewer vertices, and then use Feynman rules to obtain the expression for each term. To be precise,

$$\langle \Omega|T\{\phi(x_1) \cdots \phi(x_n)\}|\Omega\rangle$$

is equal to the sum of (expressions corresponding to) all connected diagrams with n external points. (Connected diagrams are those in which every vertex is connected to an external point through lines. Components that are totally disconnected from external lines are sometimes called "vacuum bubbles".) In the ϕ^4 interaction theory discussed above, every vertex must have four legs.^{[1]:98}

In realistic applications, the scattering amplitude of a certain interaction or the **decay rate** of a particle can be computed from the **S-matrix**, which itself can be found using the Feynman diagram method.^{[1]: 102–115}

Feynman diagrams devoid of "loops" are called tree-level diagrams, which describe the lowest-order interaction processes; those containing n loops are referred to as n -loop diagrams, which describe higher-order contributions, or radiative corrections, to the interaction.^{[31]: 44} Lines whose end points are vertices can be thought of as the propagation of **virtual particles**.^{[1]: 31}

Renormalization [edit]

Main article: Renormalization

Feynman rules can be used to directly evaluate tree-level diagrams. However, naïve computation of loop diagrams such as the one shown above will result in divergent momentum integrals, which seems to imply that almost all terms in the perturbative expansion are infinite. The **renormalisation** procedure is a systematic process for removing such infinities.

Parameters appearing in the Lagrangian, such as the mass m and the coupling constant λ , have no physical meaning — m , λ , and the field strength ϕ are not experimentally measurable quantities and are referred to here as the bare mass, bare coupling constant, and bare field, respectively. The physical mass and coupling constant are measured in some interaction process and are generally different from the bare quantities. While computing physical quantities from this interaction process, one may limit the domain of divergent momentum integrals to be below some momentum cut-off Λ , obtain expressions for the physical quantities, and then take the limit $\Lambda \rightarrow \infty$. This is an example of **regularization**, a class of methods to treat divergences in QFT, with Λ being the regulator.

The approach illustrated above is called bare perturbation theory, as calculations involve only the bare quantities such as mass and coupling constant. A different approach, called renormalized perturbation theory, is to use physically meaningful quantities from the very beginning. In the case of ϕ^4 theory, the field strength is first redefined:

$$\phi = Z^{1/2} \phi_r,$$

where ϕ is the bare field, ϕ_r is the renormalized field, and Z is a constant to be determined. The Lagrangian density becomes:

$$\mathcal{L} = \frac{1}{2}(\partial_\mu \phi_r)(\partial^\mu \phi_r) - \frac{1}{2}m_r^2 \phi_r^2 - \frac{\lambda_r}{4!} \phi_r^4 + \frac{1}{2} \delta_Z (\partial_\mu \phi_r)(\partial^\mu \phi_r) - \frac{1}{2} \delta_m \phi_r^2 - \frac{\delta_\lambda}{4!} \phi_r^4,$$

where m_r and λ_r are the experimentally measurable, renormalized, mass and coupling constant, respectively, and

$$\delta_Z = Z - 1, \quad \delta_m = m^2 Z - m_r^2, \quad \delta_\lambda = \lambda Z^2 - \lambda_r$$

are constants to be determined. The first three terms are the ϕ^4 Lagrangian density written in terms of the renormalized quantities, while the latter three terms are referred to as "counterterms". As the Lagrangian now contains more terms, so the Feynman diagrams should include additional elements, each with their own Feynman rules. The procedure is outlined as follows. First select a regularization scheme (such as the cut-off regularization introduced above or **dimensional regularization**); call the regulator Λ . Compute Feynman diagrams, in which divergent terms will depend on Λ . Then, define δ_Z , δ_m , and δ_λ such that Feynman diagrams for the counterterms will exactly cancel the divergent terms in the normal Feynman diagrams when the limit $\Lambda \rightarrow \infty$ is taken. In this way, meaningful finite quantities are obtained.^{[1]: 323–326}

It is only possible to eliminate all infinities to obtain a finite result in renormalizable theories, whereas in non-renormalizable theories infinities cannot be removed by the redefinition of a small number of parameters. The **Standard Model** of elementary particles is a renormalizable QFT,^{[1]: 719–727} while **quantum gravity** is non-renormalizable.^{[1]: 798[31]: 421}

Renormalization group [edit]

Main article: Renormalization group

The **renormalization group**, developed by **Kenneth Wilson**, is a mathematical apparatus used to study the changes in physical parameters (coefficients in the Lagrangian) as the system is viewed at different scales.^{[1]:393} The way in which each parameter changes with scale is described by its **β function**.^{[1]:417} Correlation functions, which underlie quantitative physical predictions, change with scale according to the **Callan–Symanzik equation**.^{[1]:410–411}

As an example, the coupling constant in QED, namely the **elementary charge** e , has the following **β function**:

$$\beta(e) \equiv \frac{1}{\Lambda} \frac{de}{d\Lambda} = \frac{e^3}{12\pi^2} + O(e^5),$$

where Λ is the energy scale under which the measurement of e is performed. This **differential equation** implies that the observed elementary charge increases as the scale increases.^[34] The renormalized coupling constant, which changes with the energy scale, is also called the running coupling constant.^{[1]:420}

The coupling constant g in **quantum chromodynamics**, a non-Abelian gauge theory based on the symmetry group **SU(3)**, has the following **β function**:

$$\beta(g) \equiv \frac{1}{\Lambda} \frac{dg}{d\Lambda} = \frac{g^3}{16\pi^2} \left(-11 + \frac{2}{3} N_f \right) + O(g^5),$$

where N_f is the number of **quark flavours**. In the case where $N_f \leq 16$ (the Standard Model has $N_f = 6$), the coupling constant g decreases as the energy scale increases. Hence, while the strong interaction is strong at low energies, it becomes very weak in high-energy interactions, a phenomenon known as **asymptotic freedom**.^{[1]:531}

Conformal field theories (CFTs) are special QFTs that admit **conformal symmetry**. They are insensitive to changes in the scale, as all their coupling constants have vanishing **β function**. (The converse is not true, however — the vanishing of all **β functions** does not imply conformal symmetry of the theory.)^[35] Examples include **string theory**^[25] and **$N = 4$ supersymmetric Yang–Mills theory**.^[36]

According to Wilson's picture, every QFT is fundamentally accompanied by its energy cut-off Λ , *i.e.* that the theory is no longer valid at energies higher than Λ , and all degrees of freedom above the scale Λ are to be omitted. For example, the cut-off could be the inverse of the atomic spacing in a condensed matter system, and in elementary particle physics it could be associated with the fundamental "graininess" of spacetime caused by quantum fluctuations in gravity. The cut-off scale of theories of particle interactions lies far beyond current experiments. Even if the theory were very complicated at that scale, as long as its couplings are sufficiently weak, it must be described at low energies by a renormalizable **effective field theory**.^{[1]:402–403} The difference between renormalizable and non-renormalizable theories is that the former are insensitive to details at high energies, whereas the latter do depend on them.^{[8]:2} According to this view, non-renormalizable theories are to be seen as low-energy effective theories of a more fundamental theory. The failure to remove the cut-off Λ from calculations in such a theory merely indicates that new physical phenomena appear at scales above Λ , where a new theory is necessary.^{[31]:156}

Other theories [edit]

The quantization and renormalization procedures outlined in the preceding sections are performed for the free theory and **ϕ^4 theory** of the real scalar field. A similar process can be done for other types of fields, including the **complex scalar field**, the **vector field**, and the **Dirac field**, as well as other types of interaction terms, including the electromagnetic interaction and the **Yukawa interaction**.

As an example, **quantum electrodynamics** contains a Dirac field ψ representing the **electron** field and a vector field A^μ representing the electromagnetic field (**photon** field). (Despite its name, the quantum electromagnetic "field" actually corresponds to the classical **electromagnetic four-potential**, rather than the classical electric and magnetic fields.) The full QED Lagrangian density is:

$$\mathcal{L} = \bar{\psi} (i\gamma^\mu \partial_\mu - m) \psi - \frac{1}{4} F_{\mu\nu} F^{\mu\nu} - e\bar{\psi}\gamma^\mu \psi A_\mu,$$

where γ^μ are **Dirac matrices**, $\bar{\psi} = \psi^\dagger \gamma^0$, and $F_{\mu\nu} = \partial_\mu A_\nu - \partial_\nu A_\mu$ is the **electromagnetic field strength**. The parameters in this theory are the (bare) electron mass m and the (bare) **elementary charge** e . The first and second terms in the Lagrangian density correspond to the free Dirac field and free vector fields, respectively. The last term describes the interaction between the electron and photon fields, which is treated as a perturbation from the free theories.^{[1]:78}

Shown above is an example of a tree-level Feynman diagram in QED. It describes an electron and a positron annihilating, creating an **off-shell** photon, and then decaying into a new pair of electron and positron. Time runs from left to right. Arrows pointing forward in time represent the propagation of electrons, while those pointing backward in time represent the propagation of positrons. A wavy line represents the propagation of a photon. Each vertex in QED Feynman diagrams must have an incoming and an outgoing fermion (positron/electron) leg as well as a photon leg.

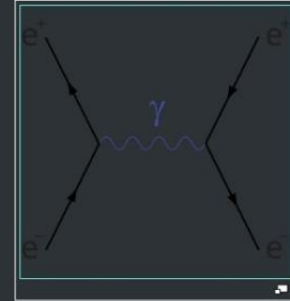

Gauge symmetry [edit]

Main article: Gauge theory

If the following transformation to the fields is performed at every spacetime point x (a local transformation), then the QED Lagrangian remains unchanged, or invariant:

$$\psi(x) \rightarrow e^{i\alpha(x)} \psi(x), \quad A_\mu(x) \rightarrow A_\mu(x) + ie^{-1} e^{-i\alpha(x)} \partial_\mu e^{i\alpha(x)},$$

where $\alpha(x)$ is any function of spacetime coordinates. If a theory's Lagrangian (or more precisely the **action**) is invariant under a certain local transformation, then the transformation is referred to as a **gauge symmetry** of the theory.^{[1]:482–483} Gauge symmetries form a **group** at every spacetime point. In the case of QED, the successive application of two different local symmetry transformations $e^{i\alpha(x)}$ and $e^{i\alpha'(x)}$ is yet another symmetry transformation $e^{i(\alpha(x)+\alpha'(x))}$. For any $\alpha(x)$, $e^{i\alpha(x)}$ is an element of the **U(1)** group, thus QED is said to have U(1) gauge symmetry.^{[1]:496} The photon field A_μ may be referred to as the U(1) **gauge boson**.

U(1) is an **Abelian group**, meaning that the result is the same regardless of the order in which its elements are applied. QFTs can also be built on **non-Abelian groups**, giving rise to **non-Abelian gauge theories** (also known as Yang–Mills theories).^{[1]:489} **Quantum chromodynamics**, which describes the strong interaction, is a non-Abelian gauge theory with an **SU(3)** gauge symmetry. It contains three Dirac fields ψ^i , $i = 1, 2, 3$ representing **quark** fields as well as eight vector fields $A^{a,\mu}$, $a = 1, \dots, 8$ representing **gluon** fields, which are the SU(3) gauge bosons.^{[1]:547} The QCD Lagrangian density is:^{[1]:490–491}

$$\mathcal{L} = i\bar{\psi}^i \gamma^\mu (D_\mu)^{ij} \psi^j - \frac{1}{4} F_{\mu\nu}^a F^{a,\mu\nu} - m\bar{\psi}^i \psi^i,$$

where D_μ is the gauge **covariant derivative**:

$$D_\mu = \partial_\mu - igA_\mu^a t^a,$$

where g is the coupling constant, t^a are the eight **generators** of SU(3) in the **fundamental representation** (3×3 matrices),

$$F_{\mu\nu}^a = \partial_\mu A_\nu^a - \partial_\nu A_\mu^a + gf^{abc} A_\mu^b A_\nu^c,$$

and f^{abc} are the **structure constants** of SU(3). Repeated indices i, j, a are implicitly summed over following Einstein notation. This Lagrangian is invariant under the transformation:

$$\psi^i(x) \rightarrow U^{ij}(x) \psi^j(x), \quad A_\mu^a(x) t^a \rightarrow U(x) [A_\mu^a(x) t^a + ig^{-1} \partial_\mu] U^\dagger(x),$$

where $U(x)$ is an element of SU(3) at every spacetime point x :

$$U(x) = e^{i\alpha(x)^a t^a}.$$

The preceding discussion of symmetries is on the level of the Lagrangian. In other words, these are "classical" symmetries. After quantization, some theories will no longer exhibit their classical symmetries, a phenomenon called **anomaly**. For instance, in the path integral formulation, despite the invariance of the Lagrangian density $\mathcal{L}[\phi, \partial_\mu \phi]$ under a certain local transformation of the fields, the **measure** $\int \mathcal{D}\phi$ of the path integral may change.^{[31]:243} For a theory describing nature to be consistent, it must not contain any anomaly in its gauge symmetry. The Standard Model of elementary particles is a gauge theory based on the group $SU(3) \times SU(2) \times U(1)$, in which all anomalies exactly cancel.^{[1]:705–707}

The theoretical foundation of **general relativity**, the **equivalence principle**, can also be understood as a form of gauge symmetry, making general relativity a gauge theory based on the **Lorentz group**.^[37]

Noether's theorem states that every continuous symmetry, *i.e.* the parameter in the symmetry transformation being continuous rather than discrete, leads to a corresponding **conservation law**.^{[1]:17–18[31]:73} For example, the $U(1)$ symmetry of QED implies **charge conservation**.^[38]

Gauge-transformations do not relate distinct quantum states. Rather, it relates two equivalent mathematical descriptions of the same quantum state. As an example, the photon field A^μ , being a **four-vector**, has four apparent degrees of freedom, but the actual state of a photon is described by its two degrees of freedom corresponding to the **polarization**. The remaining two degrees of freedom are said to be "redundant" — apparently different ways of writing A^μ can be related to each other by a gauge transformation and in fact describe the same state of the photon field. In this sense, gauge invariance is not a "real" symmetry, but a reflection of the "redundancy" of the chosen mathematical description.^{[31]:168}

To account for the gauge redundancy in the path integral formulation, one must perform the so-called **Faddeev–Popov gauge fixing** procedure. In non-Abelian gauge theories, such a procedure introduces new fields called "ghosts". Particles corresponding to the ghost fields are called ghost particles, which cannot be detected externally.^{[1]:512–515} A more rigorous generalization of the Faddeev–Popov procedure is given by **BRST quantization**.^{[1]:517}

Spontaneous symmetry-breaking [edit]

Main article: Spontaneous symmetry breaking

Spontaneous symmetry breaking is a mechanism whereby the symmetry of the Lagrangian is violated by the system described by it.^{[1]:347}

To illustrate the mechanism, consider a linear **sigma model** containing N real scalar fields, described by the Lagrangian density:

$$\mathcal{L} = \frac{1}{2} (\partial_\mu \phi^i) (\partial^\mu \phi^i) + \frac{1}{2} \mu^2 \phi^i \phi^i - \frac{\lambda}{4} (\phi^i \phi^i)^2,$$

where μ and λ are real parameters. The theory admits an $O(N)$ global symmetry:

$$\phi^i \rightarrow R^{ij} \phi^j, \quad R \in O(N).$$

The lowest energy state (ground state or vacuum state) of the classical theory is any uniform field ϕ_0 satisfying

$$\phi_0^i \phi_0^i = \frac{\mu^2}{\lambda}.$$

Without loss of generality, let the ground state be in the N -th direction:

$$\phi_0^i = \left(0, \dots, 0, \frac{\mu}{\sqrt{\lambda}} \right).$$

The original N fields can be rewritten as:

$$\phi^i(x) = \left(\pi^1(x), \dots, \pi^{N-1}(x), \frac{\mu}{\sqrt{\lambda}} + \sigma(x) \right),$$

and the original Lagrangian density as:

$$\mathcal{L} = \frac{1}{2} (\partial_\mu \pi^k) (\partial^\mu \pi^k) + \frac{1}{2} (\partial_\mu \sigma) (\partial^\mu \sigma) - \frac{1}{2} (2\mu^2) \sigma^2 - \sqrt{\lambda} \mu \sigma^3 - \sqrt{\lambda} \mu \pi^k \pi^k \sigma - \frac{\lambda}{2} \pi^k \pi^k \sigma^2 - \frac{\lambda}{4} (\pi^k \pi^k)^2,$$

where $k = 1, \dots, N - 1$. The original $O(N)$ global symmetry is no longer manifest, leaving only the **subgroup** $O(N - 1)$. The larger symmetry before spontaneous symmetry breaking is said to be "hidden" or spontaneously broken.^{[1]:349–350}

Goldstone's theorem states that under spontaneous symmetry breaking, every broken continuous global symmetry leads to a massless field called the Goldstone boson. In the above example, $O(N)$ has $N(N - 1)/2$ continuous symmetries (the dimension of its **Lie algebra**), while $O(N - 1)$ has $(N - 1)(N - 2)/2$. The number of broken symmetries is their difference, $N - 1$, which corresponds to the $N - 1$ massless fields π^k .^{[1]:351}

On the other hand, when a gauge (as opposed to global) symmetry is spontaneously broken, the resulting Goldstone boson is "eaten" by the corresponding gauge boson by becoming an additional degree of freedom for the gauge boson. The Goldstone boson equivalence theorem states that at high energy, the amplitude for emission or absorption of a longitudinally polarized massive gauge boson becomes equal to the amplitude for emission or absorption of the Goldstone boson that was eaten by the gauge boson.^{[1]:743–744}

In the QFT of **ferromagnetism**, spontaneous symmetry breaking can explain the alignment of **magnetic dipoles** at low temperatures.^{[31]:199} In the Standard Model of elementary particles, the **W and Z bosons**, which would otherwise be massless as a result of gauge symmetry, acquire mass through spontaneous symmetry breaking of the **Higgs boson**, a process called the **Higgs mechanism**.^{[1]:690}

Supersymmetry [[edit](#)]

Main article: [Supersymmetry](#)

All experimentally known symmetries in nature relate **bosons** to bosons and **fermions** to fermions. Theorists have hypothesized the existence of a type of symmetry, called **supersymmetry**, that relates bosons and fermions.^{[1]:795[31]:443}

The Standard Model obeys **Poincaré symmetry**, whose generators are the spacetime **translations** P^μ and the **Lorentz transformations** $J_{\mu\nu}$.^{[39]:58–60} In addition to these generators, supersymmetry in (3+1)-dimensions includes additional generators Q_α , called **supercharges**, which themselves transform as **Weyl fermions**.^{[1]:795[31]:444} The symmetry group generated by all these generators is known as the **super-Poincaré group**. In general there can be more than one set of supersymmetry generators, Q_α^I , $I = 1, \dots, N$, which generate the corresponding $N = 1$ supersymmetry, $N = 2$ supersymmetry, and so on.^{[1]:795[31]:450} Supersymmetry can also be constructed in other dimensions,^[40] most notably in (1+1) dimensions for its application in **superstring theory**.^[41]

The Lagrangian of a supersymmetric theory must be invariant under the action of the super-Poincaré group.^{[31]:448} Examples of such theories include: **Minimal Supersymmetric Standard Model** (MSSM), **$N = 4$ supersymmetric Yang–Mills theory**,^{[31]:450} and superstring theory. In a supersymmetric theory, every fermion has a bosonic **superpartner** and vice versa.^{[31]:444}

If supersymmetry is promoted to a local symmetry, then the resultant gauge theory is an extension of general relativity called **supergravity**.^[42]

Supersymmetry is a potential solution to many current problems in physics. For example, the **hierarchy problem** of the Standard Model—why the mass of the Higgs boson is not radiatively corrected (under renormalization) to a very high scale such as the **grand unified scale** or the **Planck scale**—can be resolved by relating the **Higgs field** and its super-partner, the **Higgsino**. Radiative corrections due to Higgs boson loops in Feynman diagrams are cancelled by corresponding Higgsino loops. Supersymmetry also offers answers to the grand unification of all gauge coupling constants in the Standard Model as well as the nature of **dark matter**.^{[1]:796–797[43]}

Nevertheless, experiments have yet to provide evidence for the existence of supersymmetric particles. If supersymmetry were a true symmetry of nature, then it must be a broken symmetry, and the energy of symmetry breaking must be higher than those achievable by present-day experiments.^{[1]:797[31]:443}

Other spacetimes [edit]

The ϕ^4 theory, QED, QCD, as well as the whole Standard Model all assume a (3+1)-dimensional [Minkowski space](#) (3 spatial and 1 time dimensions) as the background on which the quantum fields are defined. However, QFT *a priori* imposes no restriction on the number of dimensions nor the geometry of spacetime.

In [condensed matter physics](#), QFT is used to describe (2+1)-dimensional [electron gases](#).^[44] In [high-energy physics](#), [string theory](#) is a type of (1+1)-dimensional QFT,^{[31]:452[25]} while [Kaluza–Klein theory](#) uses gravity in [extra dimensions](#) to produce gauge theories in lower dimensions.^{[31]:428–429}

In Minkowski space, the flat [metric](#) $\eta_{\mu\nu}$ is used to [raise and lower](#) spacetime indices in the Lagrangian, e.g.

$$A_\mu A^\mu = \eta_{\mu\nu} A^\mu A^\nu, \quad \partial_\mu \phi \partial^\mu \phi = \eta^{\mu\nu} \partial_\mu \phi \partial_\nu \phi,$$

where $\eta^{\mu\nu}$ is the inverse of $\eta_{\mu\nu}$ satisfying $\eta^{\mu\rho} \eta_{\rho\nu} = \delta^\mu_\nu$. For [QFTs in curved spacetime](#) on the other hand, a general metric (such as the [Schwarzschild metric](#) describing a [black hole](#)) is used:

$$A_\mu A^\mu = g_{\mu\nu} A^\mu A^\nu, \quad \partial_\mu \phi \partial^\mu \phi = g^{\mu\nu} \partial_\mu \phi \partial_\nu \phi,$$

where $g^{\mu\nu}$ is the inverse of $g_{\mu\nu}$. For a real scalar field, the Lagrangian density in a general spacetime background is

$$\mathcal{L} = \sqrt{|g|} \left(\frac{1}{2} g^{\mu\nu} \nabla_\mu \phi \nabla_\nu \phi - \frac{1}{2} m^2 \phi^2 \right),$$

where $g = \det(g_{\mu\nu})$, and ∇_μ denotes the [covariant derivative](#).^[45] The Lagrangian of a QFT, hence its calculational results and physical predictions, depends on the geometry of the spacetime background.

Topological quantum field theory

[\[edit\]](#)

Main article: [Topological quantum field theory](#)

The correlation functions and physical predictions of a QFT depend on the spacetime metric $g_{\mu\nu}$. For a special class of QFTs called [topological quantum field theories](#) (TQFTs), all correlation functions are independent of continuous changes in the spacetime metric.^{[46]:36} QFTs in curved spacetime generally change according to the *geometry* (local structure) of the spacetime background, while TQFTs are invariant under spacetime [diffeomorphisms](#) but are sensitive to the *topology* (global structure) of spacetime. This means that all calculational results of TQFTs are [topological invariants](#) of the underlying spacetime. [Chern–Simons theory](#) is an example of TQFT and has been used to construct models of quantum gravity.^[47] Applications of TQFT include the [fractional quantum Hall effect](#) and [topological quantum computers](#).^{[48]:1–5} The world line trajectory of fractionalized particles (known as [anyons](#)) can form a link configuration in the spacetime,^[49] which relates the braiding statistics of anyons in physics to the link invariants in mathematics. Topological quantum field theories (TQFTs) applicable to the frontier research of topological quantum matters include Chern-Simons-Witten gauge theories in 2+1 spacetime dimensions, other new exotic TQFTs in 3+1 spacetime dimensions and beyond.^[50]

Perturbative and non-perturbative methods

[\[edit\]](#)

Using [perturbation theory](#), the total effect of a small interaction term can be approximated order by order by a series expansion in the number of [virtual particles](#) participating in the interaction. Every term in the expansion may be understood as one possible way for (physical) particles to interact with each other via virtual particles, expressed visually using a [Feynman diagram](#). The [electromagnetic force](#) between two electrons in QED is represented (to first order in perturbation theory) by the propagation of a virtual photon. In a similar manner, the [W and Z bosons](#) carry the weak interaction, while [gluons](#) carry the strong interaction. The interpretation of an interaction as a sum of intermediate states involving the exchange of various virtual particles only makes sense in the framework of perturbation theory. In contrast, non-perturbative methods in QFT treat the interacting Lagrangian as a whole without any series expansion. Instead of particles that carry interactions, these methods have spawned such concepts as ['t Hooft–Polyakov monopole](#), [domain wall](#), [flux tube](#), and [instanton](#).^[8] Examples of QFTs that are completely solvable non-perturbatively include [minimal models](#) of [conformal field theory](#)^[51] and the [Thirring model](#).^[52]

Mathematical rigor

[\[edit\]](#)

In spite of its overwhelming success in particle physics and condensed matter physics, QFT itself lacks a formal mathematical foundation. For example, according to [Haag's theorem](#), there does not exist a well-defined [interaction picture](#) for QFT, which implies that [perturbation theory](#) of QFT, which underlies the entire [Feynman diagram](#) method, is fundamentally ill-defined.^[53]

However, *perturbative* quantum field theory, which only requires that quantities be computable as a formal power series without any convergence requirements, can be given a rigorous mathematical treatment. In particular, [Kevin Costello's](#) monograph *Renormalization and Effective Field Theory*^[54] provides a rigorous formulation of perturbative renormalization that combines both the effective-field theory approaches of [Kadanoff](#), [Wilson](#), and [Polchinski](#), together with the [Batalin-Vilkovisky](#) approach to quantizing gauge theories. Furthermore, perturbative path-integral methods, typically understood as formal computational methods inspired from finite-dimensional integration theory,^[55] can be given a sound mathematical interpretation from their finite-dimensional analogues.^[56]

Since the 1950s,^[57] theoretical physicists and mathematicians have attempted to organize all QFTs into a set of [axioms](#), in order to establish the existence of concrete models of relativistic QFT in a mathematically rigorous way and to study their properties. This line of study is called [constructive quantum field theory](#), a subfield of [mathematical physics](#),^{[58]:2} which has led to such results as [CPT theorem](#), [spin–statistics theorem](#), and [Goldstone's theorem](#),^[57] and also to mathematically rigorous constructions of many interacting QFTs in two and three spacetime dimensions, e.g.

two-dimensional scalar field theories with arbitrary polynomial interactions,^[59] the three-dimensional scalar field theories with a quartic interaction, etc.^[60]

Compared to ordinary QFT, [topological quantum field theory](#) and [conformal field theory](#) are better supported mathematically — both can be classified in the framework of [representations](#) of [cobordisms](#).^[61]

[Algebraic quantum field theory](#) is another approach to the axiomatization of QFT, in which the fundamental objects are local operators and the algebraic relations between them. Axiomatic systems following this approach include [Wightman axioms](#) and [Haag–Kastler axioms](#).^{[58]:2–3} One way to construct theories satisfying Wightman axioms is to use [Osterwalder–Schrader axioms](#), which give the necessary and sufficient conditions for a real time theory to be obtained from an [imaginary time](#) theory by [analytic continuation](#) ([Wick rotation](#)).^{[58]:10}

[Yang–Mills existence and mass gap](#), one of the [Millennium Prize Problems](#), concerns the well-defined existence of [Yang–Mills theories](#) as set out by the above axioms. The full problem statement is as follows.^[62]

Prove that for any [compact simple gauge group](#) G , a non-trivial quantum Yang–Mills

theory exists on \mathbb{R}^4 and has a [mass gap](#) $\Delta > 0$. Existence includes establishing axiomatic properties at least as strong as those cited in [Streater & Wightman \(1964\)](#), [Osterwalder & Schrader \(1973\)](#) and [Osterwalder & Schrader \(1975\)](#).

See also

[\[edit\]](#)

•  [Mathematics portal](#)

•  [Physics portal](#)

- [Abraham–Lorentz force](#)
- [AdS/CFT correspondence](#)
- [Axiomatic quantum field theory](#)
- [Introduction to quantum mechanics](#)
- [Common integrals in quantum field theory](#)
- [Conformal field theory](#)
- [Constructive quantum field theory](#)
- [Dirac's equation](#)
- [Form factor \(quantum field theory\)](#)
- [Feynman diagram](#)
- [Green–Kubo relations](#)
- [Green's function \(many-body theory\)](#)
- [Group field theory](#)

- [Lattice field theory](#)
- [List of quantum field theories](#)
- [Local quantum field theory](#)
- [Noncommutative quantum field theory](#)
- [Quantization of a field](#)
- [Quantum electrodynamics](#)
- [Quantum field theory in curved spacetime](#)
- [Quantum chromodynamics](#)
- [Quantum flavordynamics](#)
- [Quantum hadrodynamics](#)
- [Quantum hydrodynamics](#)
- [Quantum triviality](#)
- [Relation between Schrödinger's equation and the path integral formulation of quantum mechanics](#)
- [Relationship between string theory and quantum field theory](#)
- [Schwinger–Dyson equation](#)
- [Static forces and virtual-particle exchange](#)
- [Symmetry in quantum mechanics](#)
- [Topological quantum field theory](#)
- [Ward–Takahashi identity](#)
- [Wheeler–Feynman absorber theory](#)
- [Wigner's classification](#)
- [Wigner's theorem](#)