

| REVISIONS | | | | |
|-----------|------|-------------|------|----------|
| ZONE | REV. | DESCRIPTION | DATE | APPROVED |
| | | | | |

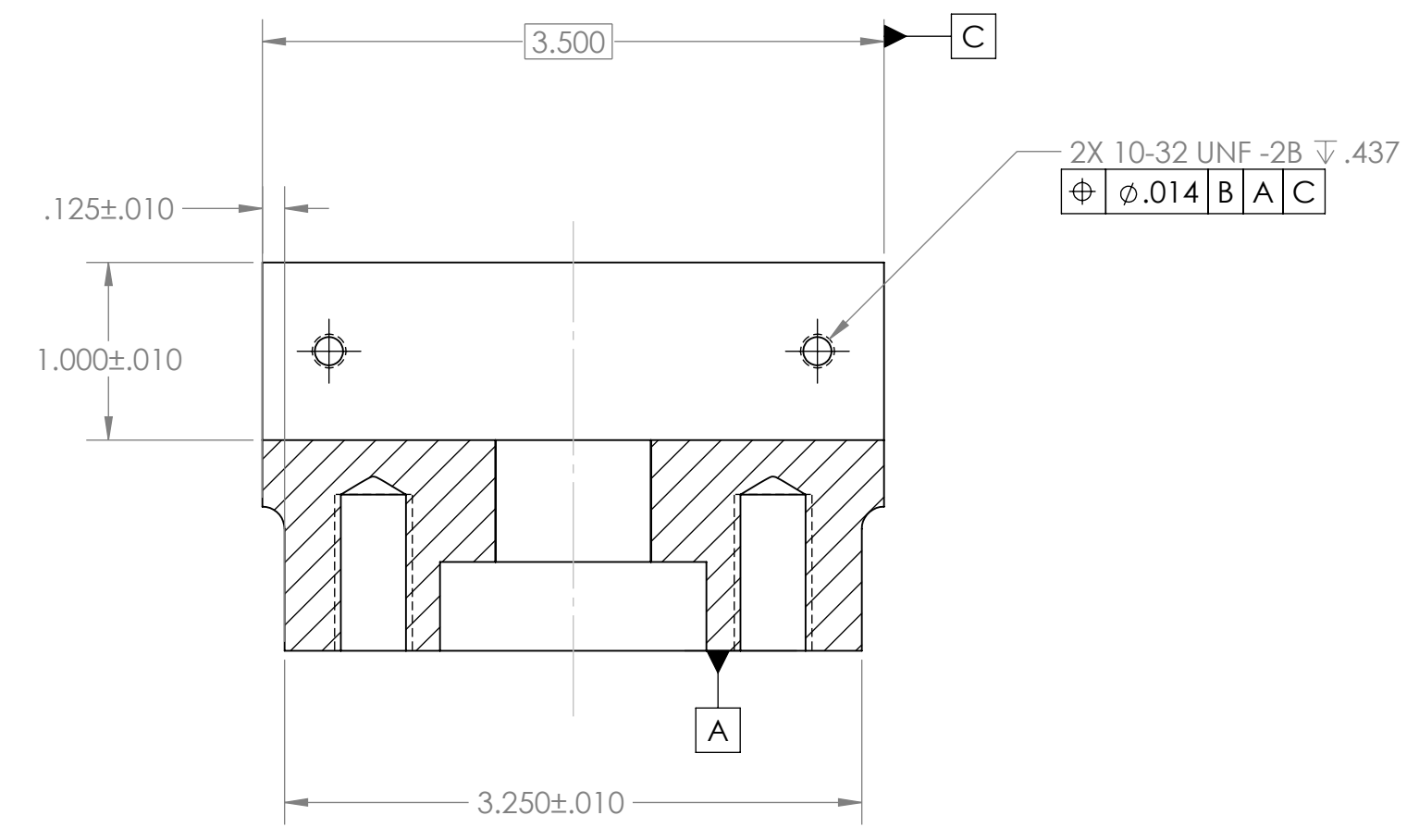

SECTION G-G

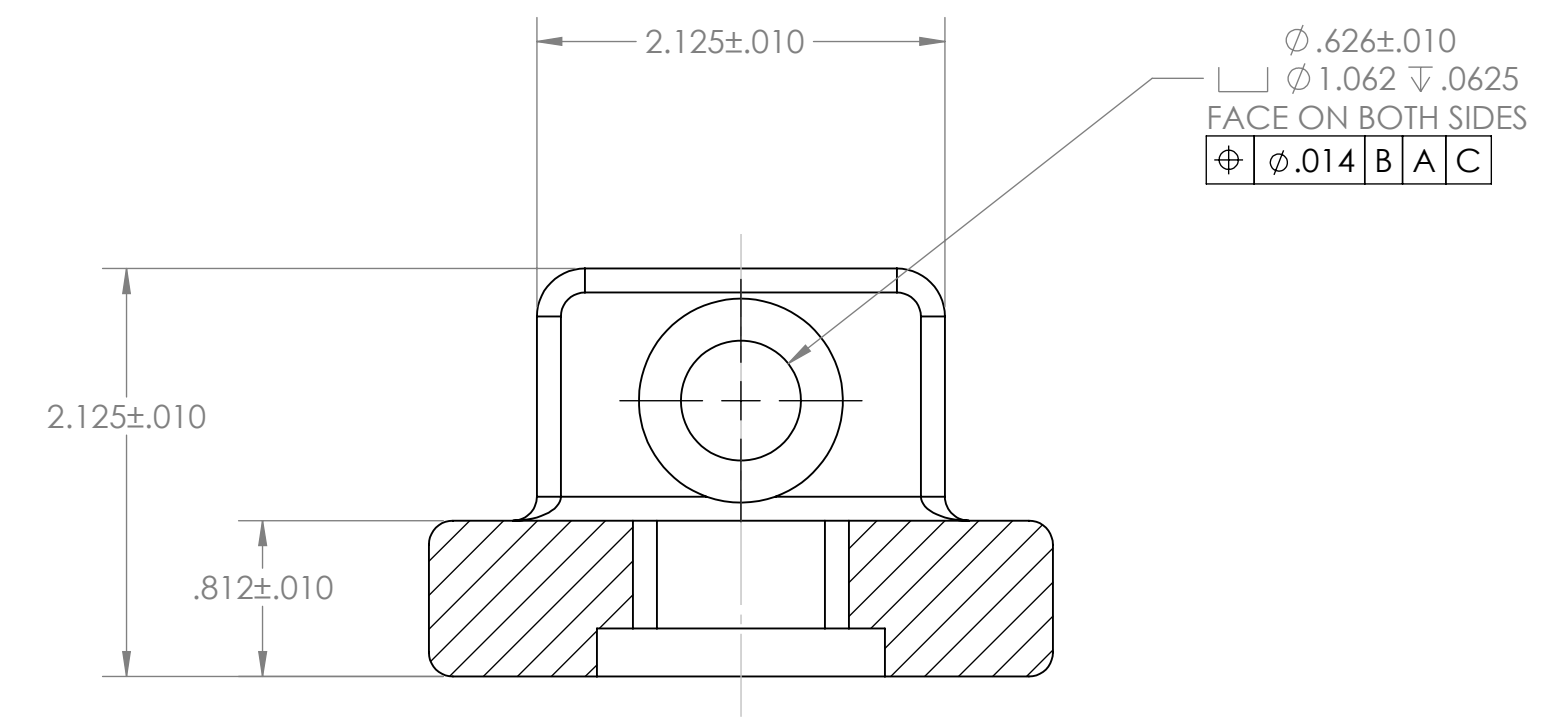
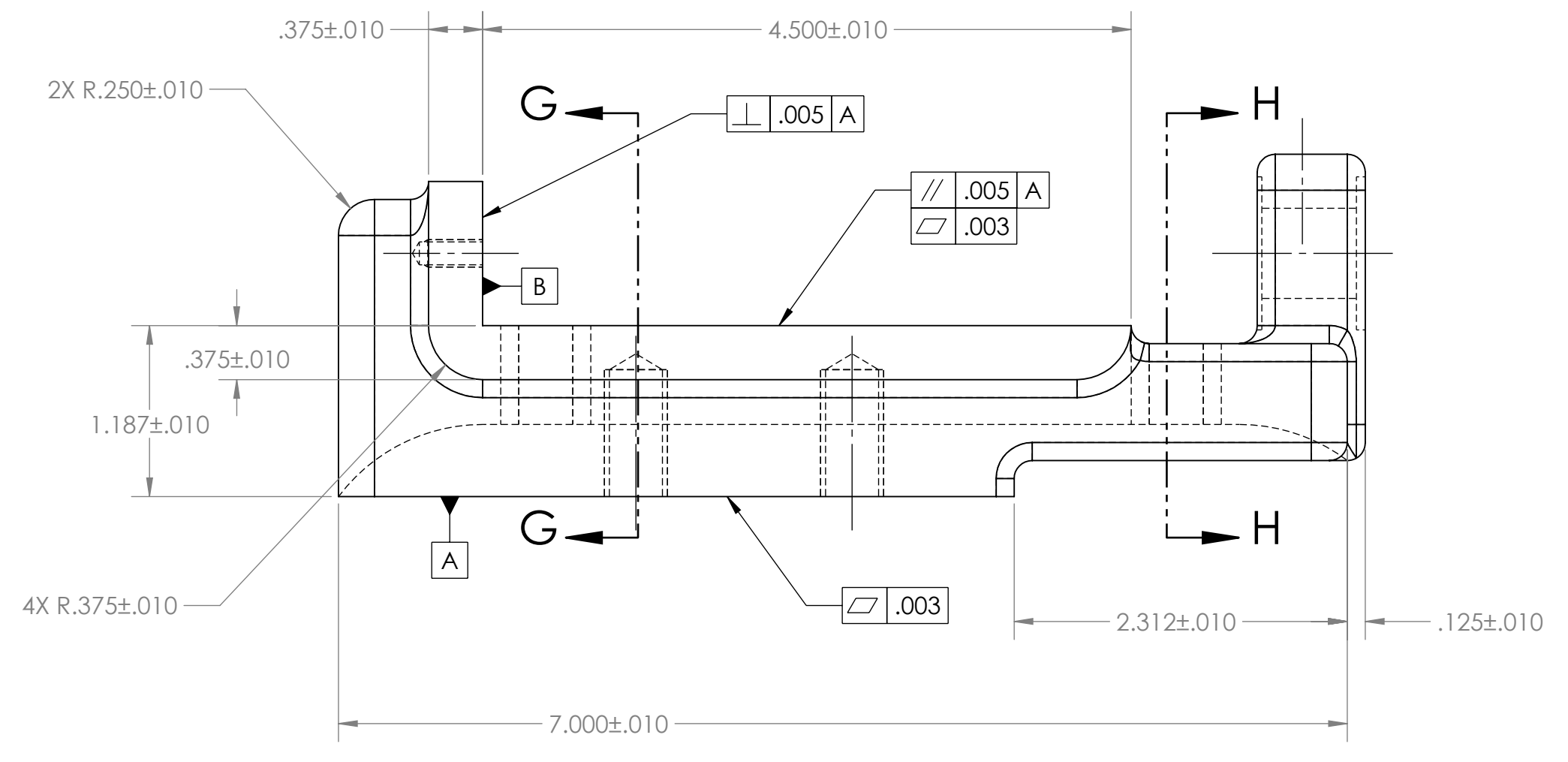

SECTION H-H

NOTES: UNLESS OTHERWISE SPECIFIED:

1. INTERPRET DRAWING IN ACCORANCE WITH INDUSTRY STANDARDS PRESCRIBED BY ASME Y.14.5-2018 AND MILL-T-31000.
2. MATERIAL: CAST CARBON STEEL
3. ALL FILLETS AND ROUNDS R.125.
4. REMOVE ALL BURRS AND SHARP EDGES.

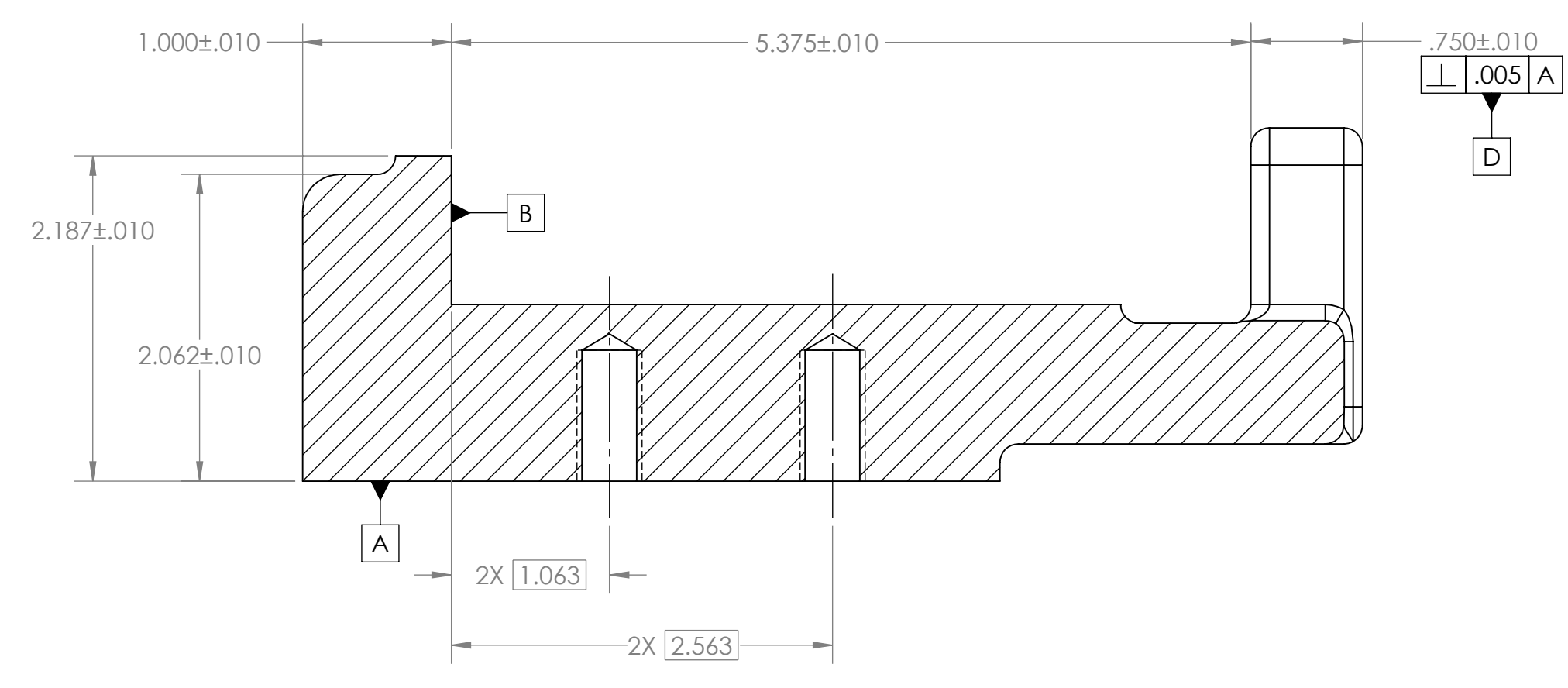

SECTION F-F

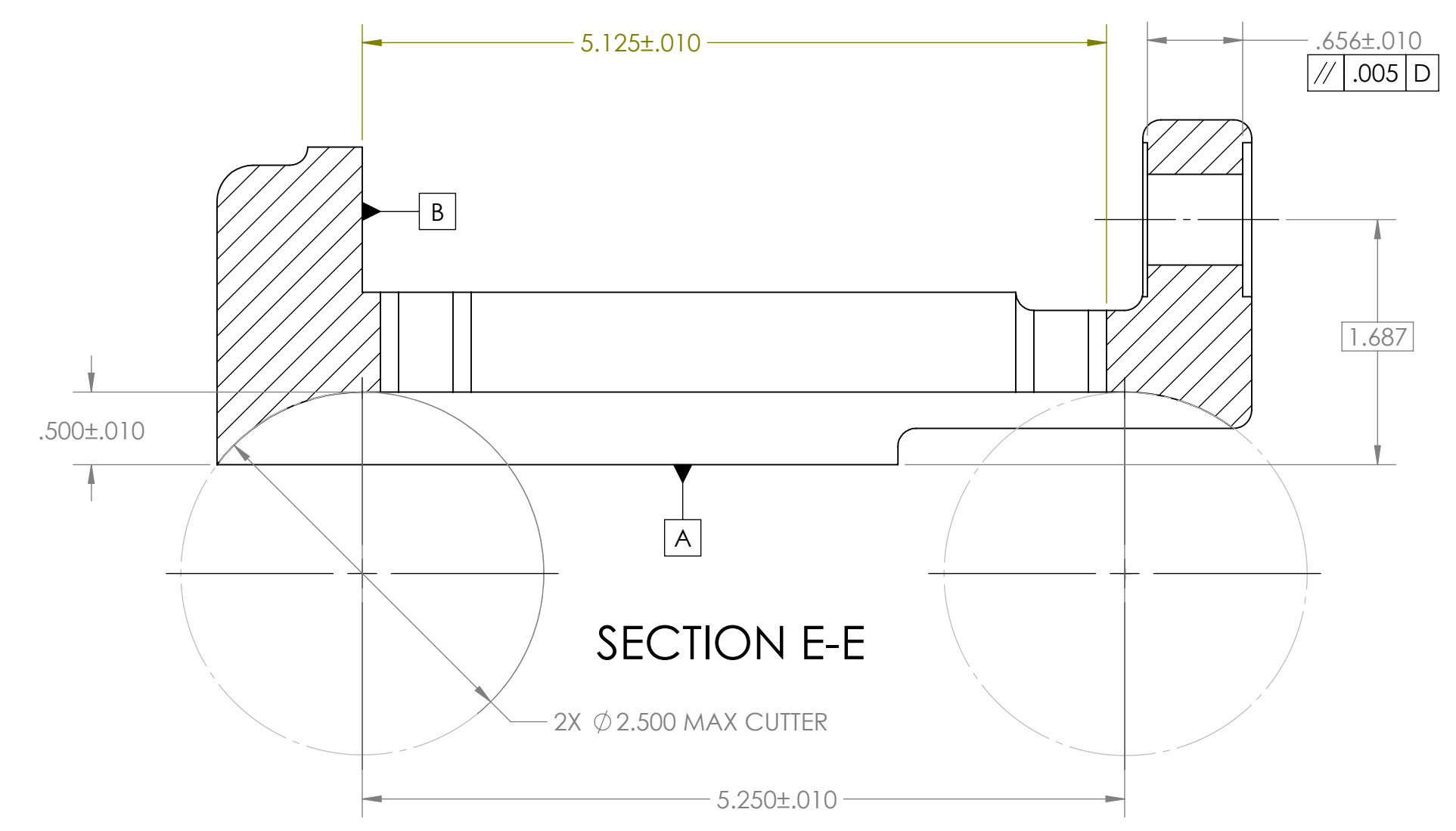

SECTION E-E

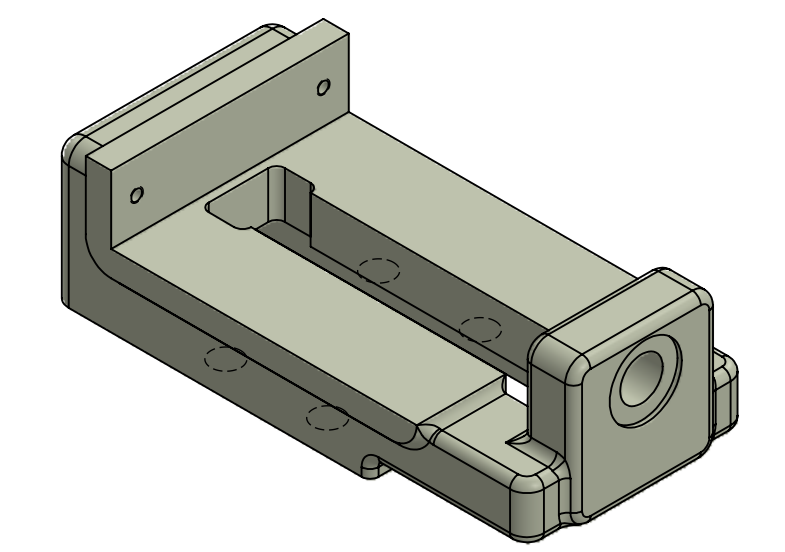
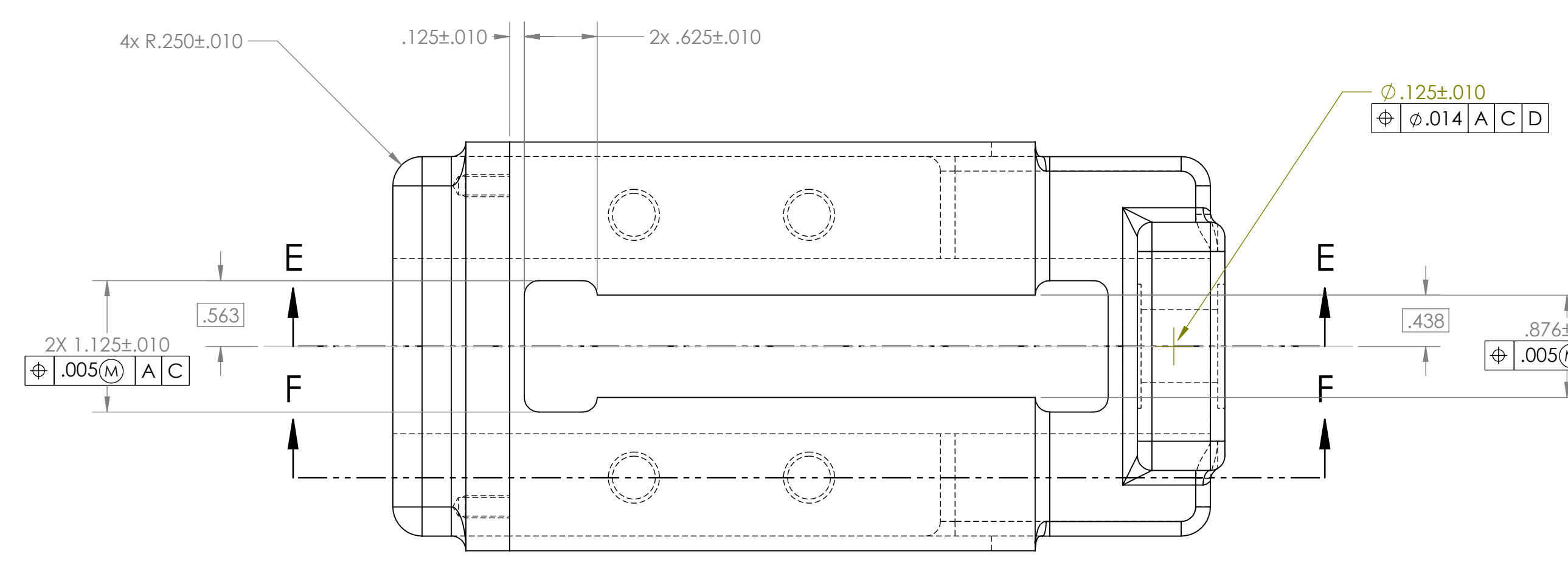
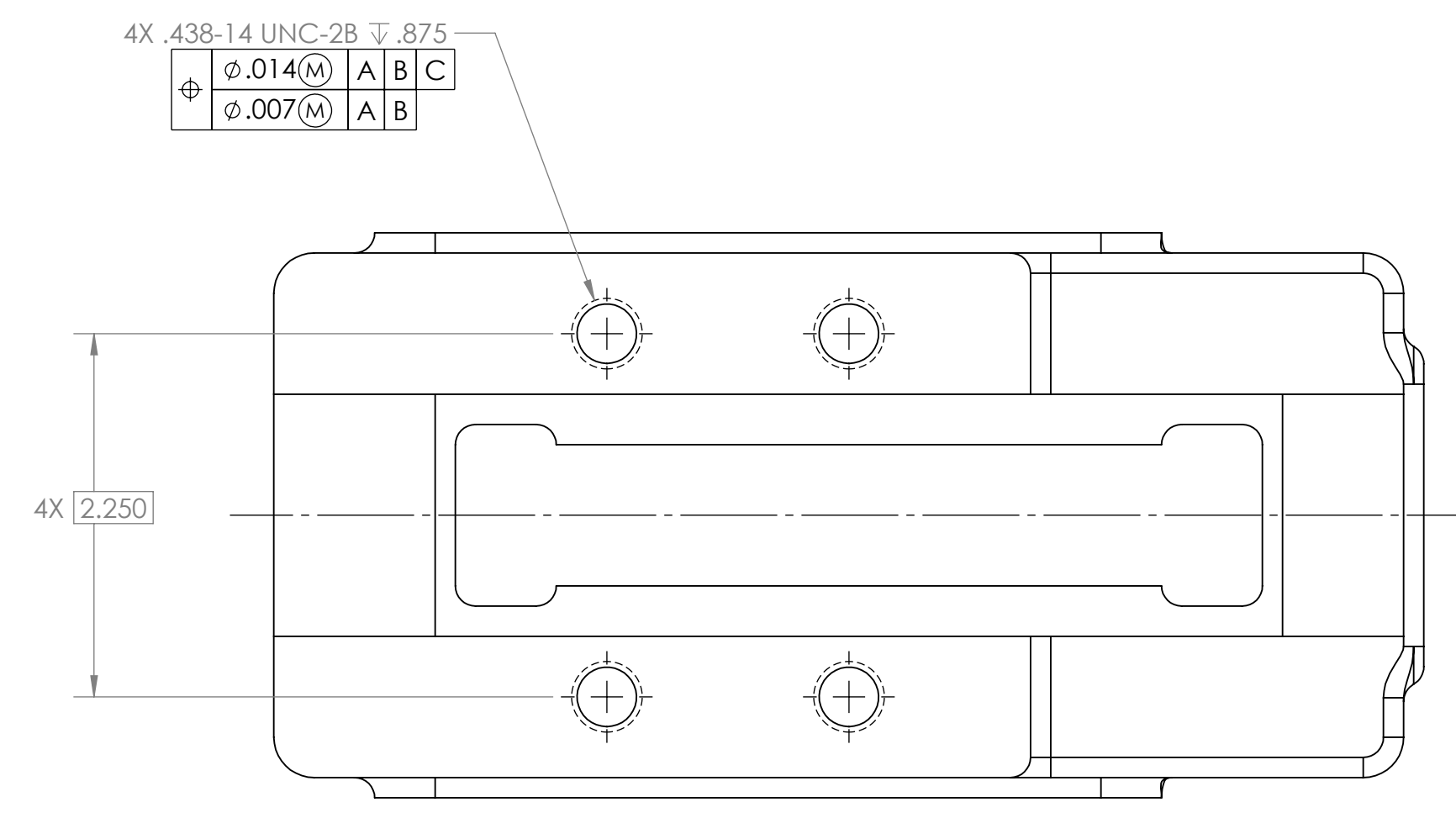

PROPRIETARY AND CONFIDENTIAL
THE INFORMATION CONTAINED IN THIS DRAWING IS THE SOLE PROPERTY OF LWTECH. ANY REPRODUCTION IN PART OR AS A WHOLE WITHOUT THE WRITTEN PERMISSION OF LWTECH IS PROHIBITED.

| UNLESS OTHERWISE SPECIFIED: | | NAME | DATE |
|---|----------------------|-----------|----------|
| DIMENSIONS ARE IN INCHES | DRAWN | VILARANCA | 10/26/23 |
| TOLERANCES: | CHECKED | | |
| FRACTIONAL: 1/16 | ENG APPR. | | |
| ANGULAR: MACH±1° | MEG APPR. | | |
| TWO PLACE DECIMAL ±.02 | Q.A. | | |
| THREE PLACE DECIMAL ±.010 | COMMENTS: | | |
| HEREBY GEOMETRIC TOLERANCES PER: ASME Y14.5-2018 AND MILL-T-31000 | | | |
| MATERIAL: | | | |
| FINISH: | | | |
| APPLICATION | DO NOT SCALE DRAWING | | |

| | | | |
|---------------|-----------|--------------|--|
| LWTECH | | TITLE: | |
| BASE, VISE | | REV | |
| SIZE DWG. NO. | D 14-52-1 | - | |
| SCALE: 1:1 | WEIGHT: | SHEET 1 OF 1 | |