

REVISIONS				
ZONE	REV.	DESCRIPTION	DATE	APPROVED

**NOTES: UNLESS OTHERWISE SPECIFIED:**

1. INTERPRET DRAWING IN ACCORDANCE WITH INDUSTRY STANDARDS PRESCRIBED BY ASME Y.14.5-2018 AND MILL-T-31000.
2. MATERIAL: CAST CARBON STEEL
3. ALL FILLETS AND ROUNDS R.050.
4. REMOVE ALL BURRS AND SHARP EDGES.

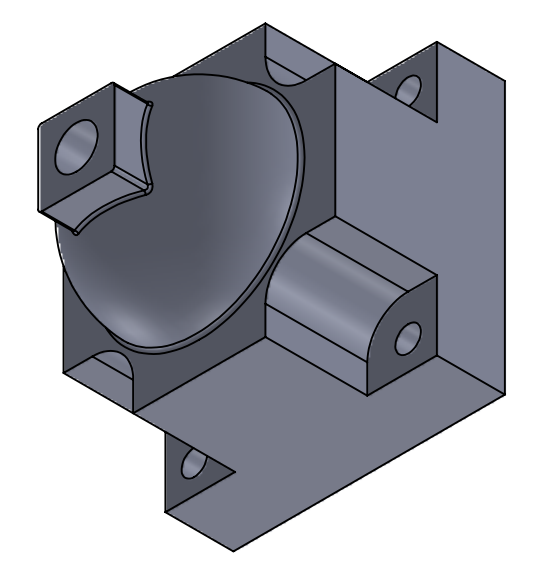
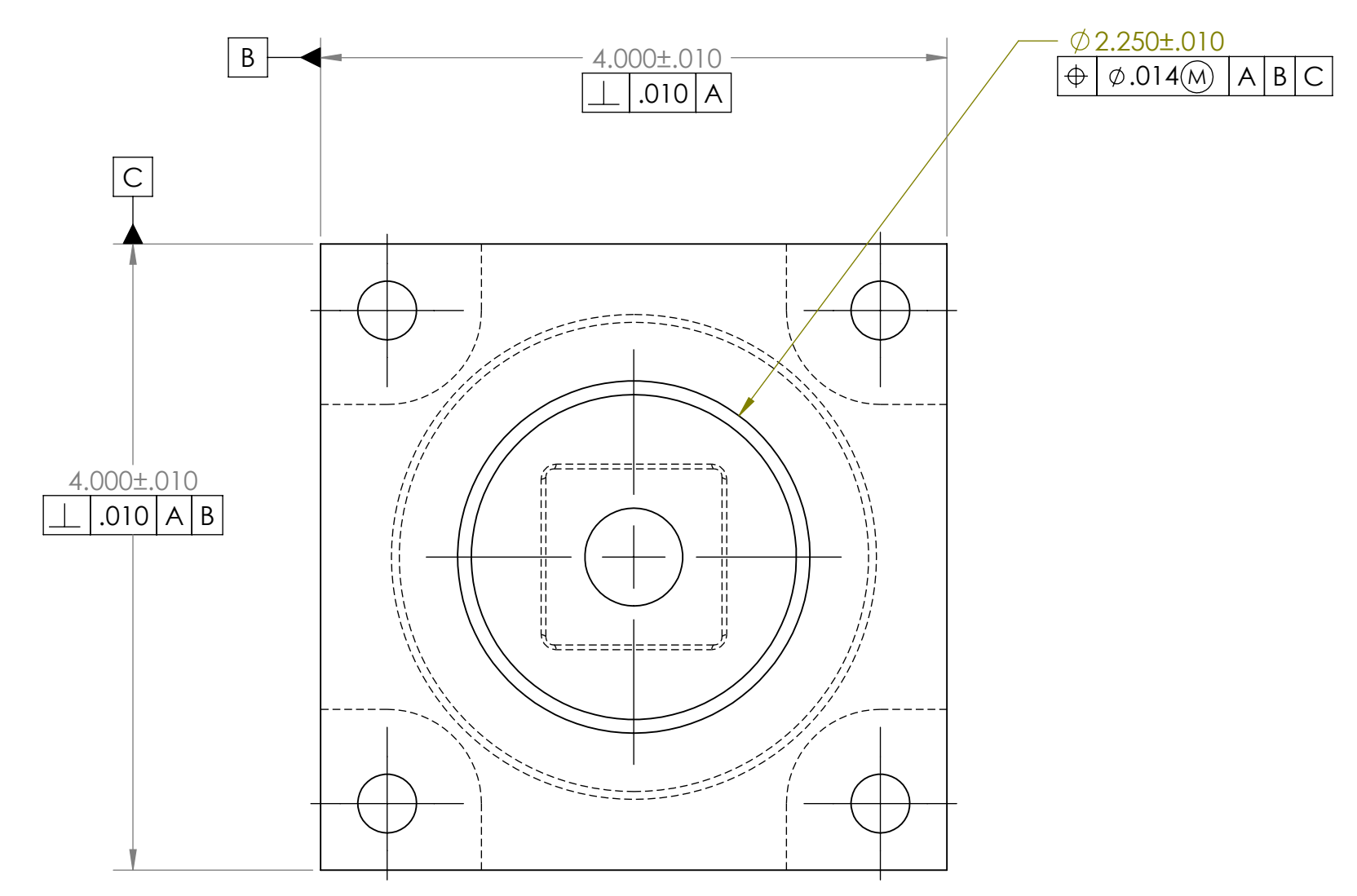
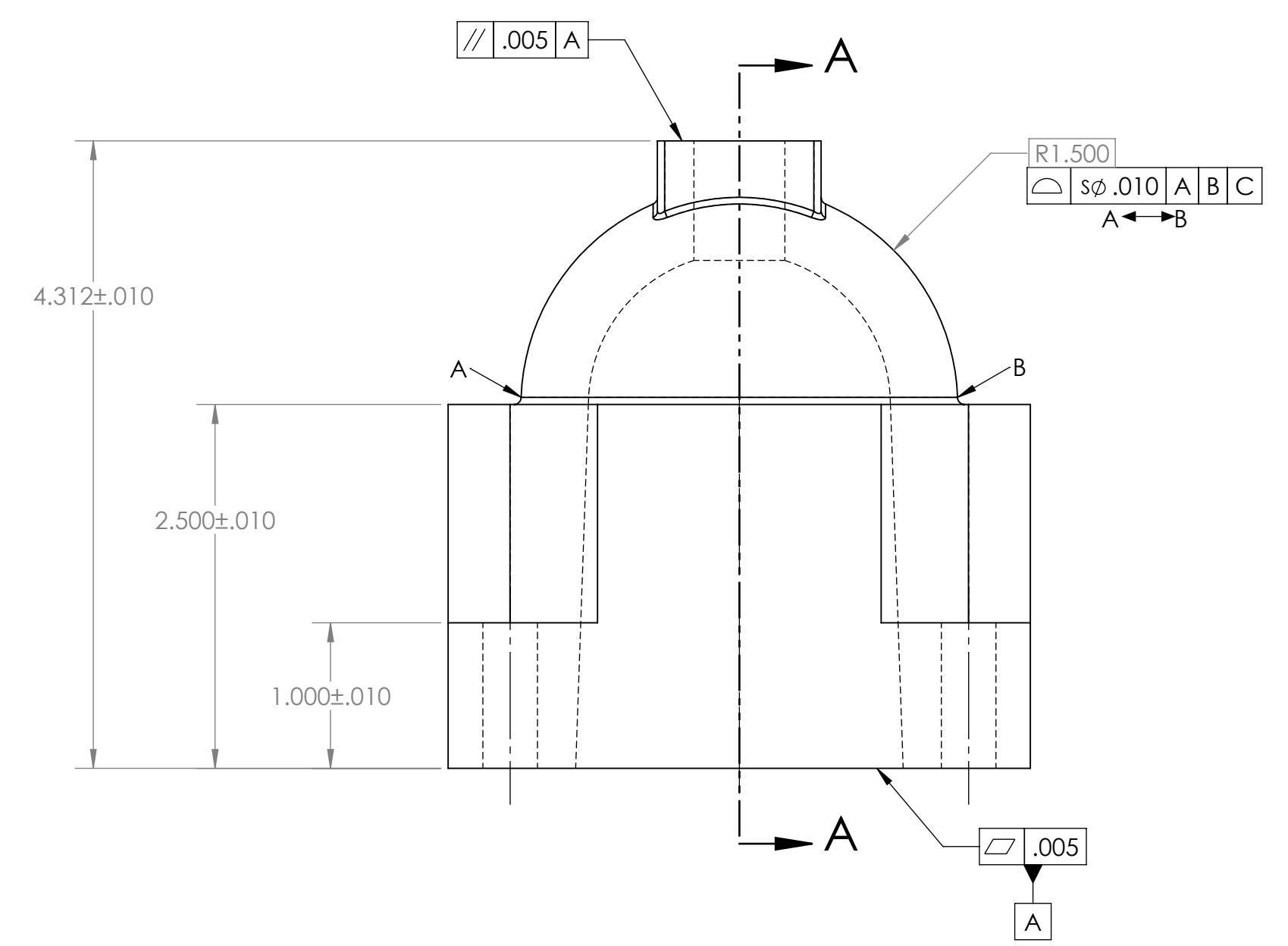
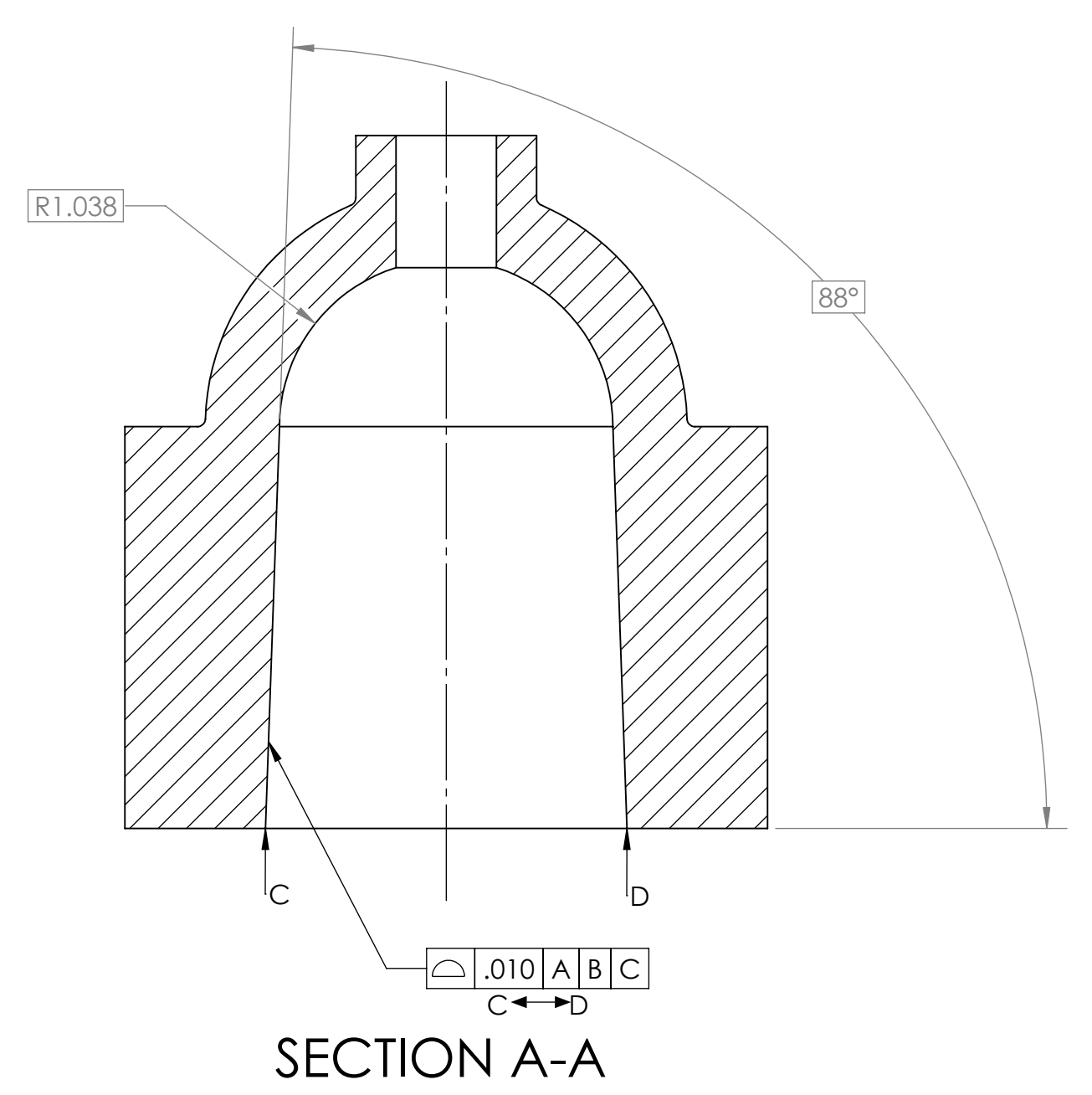
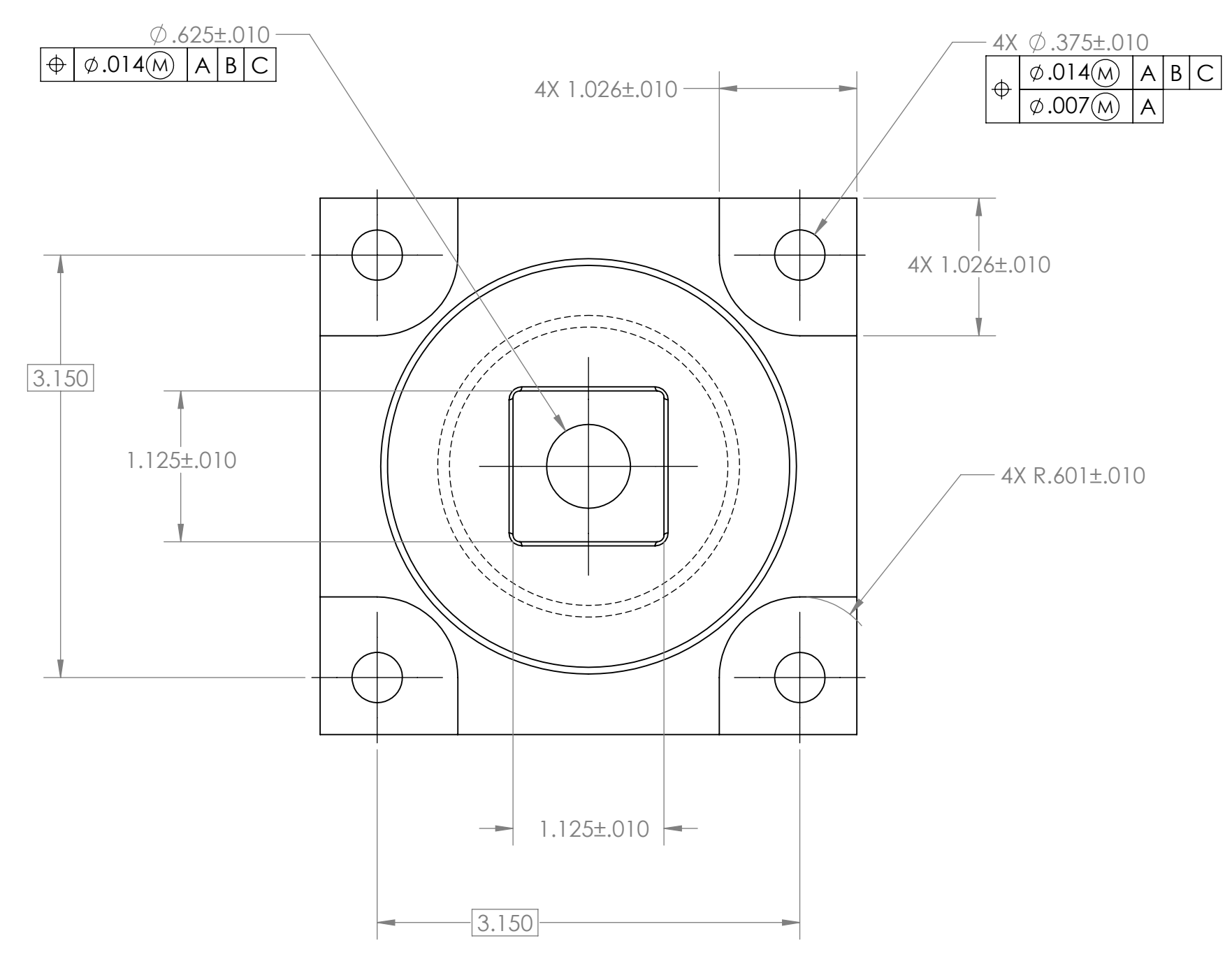

PROPRIETARY AND CONFIDENTIAL  
 THE INFORMATION CONTAINED IN THIS DRAWING IS THE SOLE PROPERTY OF  
 LWTECH. ANY REPRODUCTION OR  
 TRANSMISSION IN ANY FORM OR BY ANY  
 MEANS WITHOUT THE WRITTEN PERMISSION OF  
 LWTECH IS PROHIBITED.

UNLESS OTHERWISE SPECIFIED:	NAME	DATE	LWTECH	
DIMENSIONS ARE IN INCHES	DRAWN	MAV	11/01/23	TITLE:
TOLERANCES:	CHECKED			MV-CAST PART
FRACTIONAL: 1/64	ENG APPR.			
ANGULAR: MACH ± 1° BEND ± 1°	MFG APPR.			
TWO PLACE DECIMAL ±.010				
THREE PLACE DECIMAL ±.005				
INTERPRET GEOMETRIC TOLERANCING PER:	Q.A.			
MATERIAL:	COMMENTS:			
CAST STAINLESS STEEL				
FINISH:				
APPLICATION	DO NOT SCALE DRAWING			

SIZE	DWG. NO.	REV
D	CAST PART 1	-
SCALE: 1:1	WEIGHT:	SHEET 1 OF 1