

CAD MAINTAINED.
CHANGES SHALL BE
INCORPORATED BY
THE DESIGN
ACTIVITY.

REVISIONS				
ZONE	REV.	DESCRIPTION	DATE	APPROVED

- NOTES: UNLESS OTHERWISE SPECIFIED:**
1. INTERPRET DRAWING IN ACCORDANCE WITH INDUSTRY STANDARDS PERSCRIBED BY ASME Y.14.5-2018 AND MILL-T-31000.
 2. MATERIAL: SAE 1060 ALLOY.
 3. ALL FILLETS AND ROUNDS R.100.
 4. REMOVE ALL BURRS AND SHARP EDGES.
 5. DO NOT SCALE DRAWING.
 6. SURFACE FINISH 120

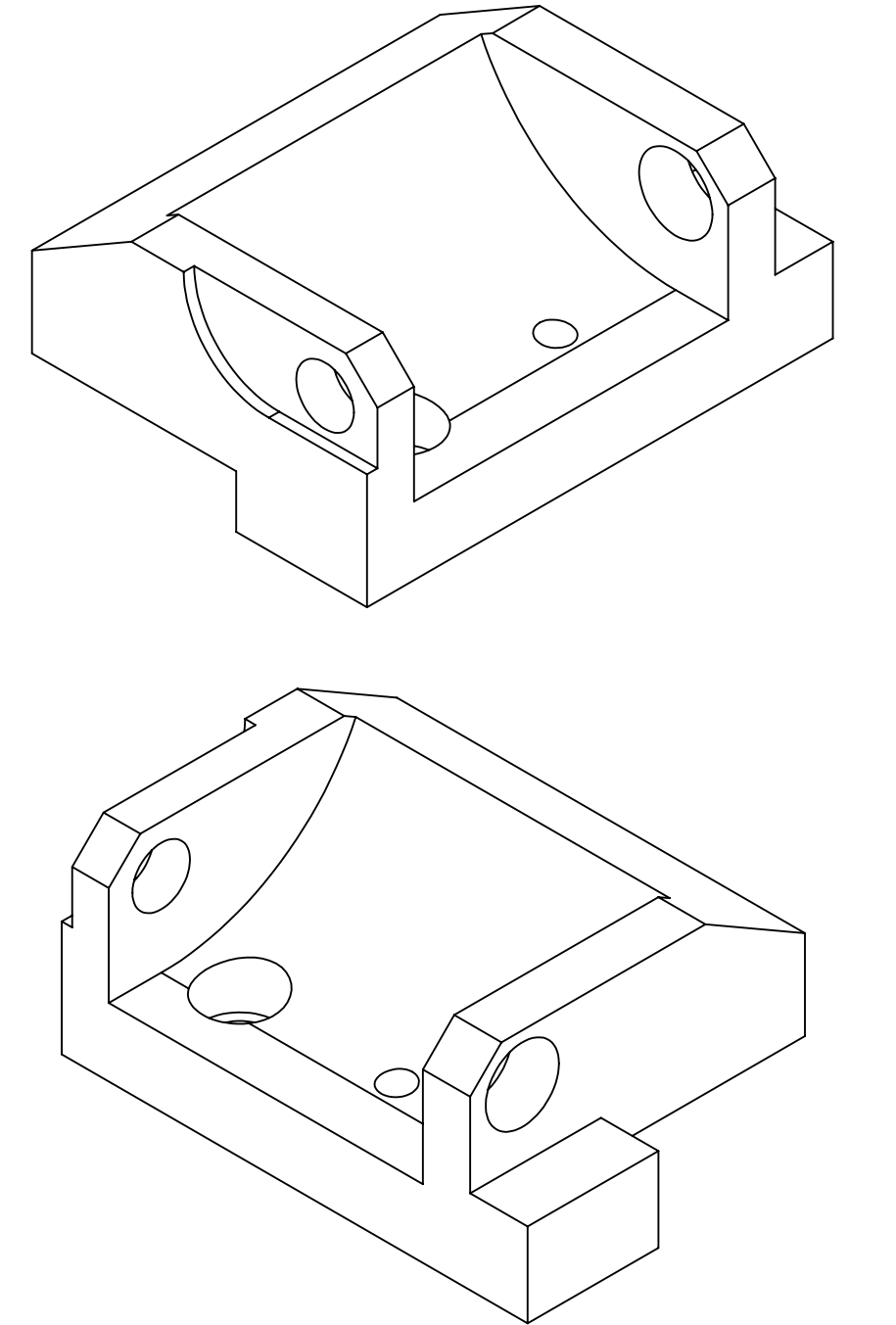
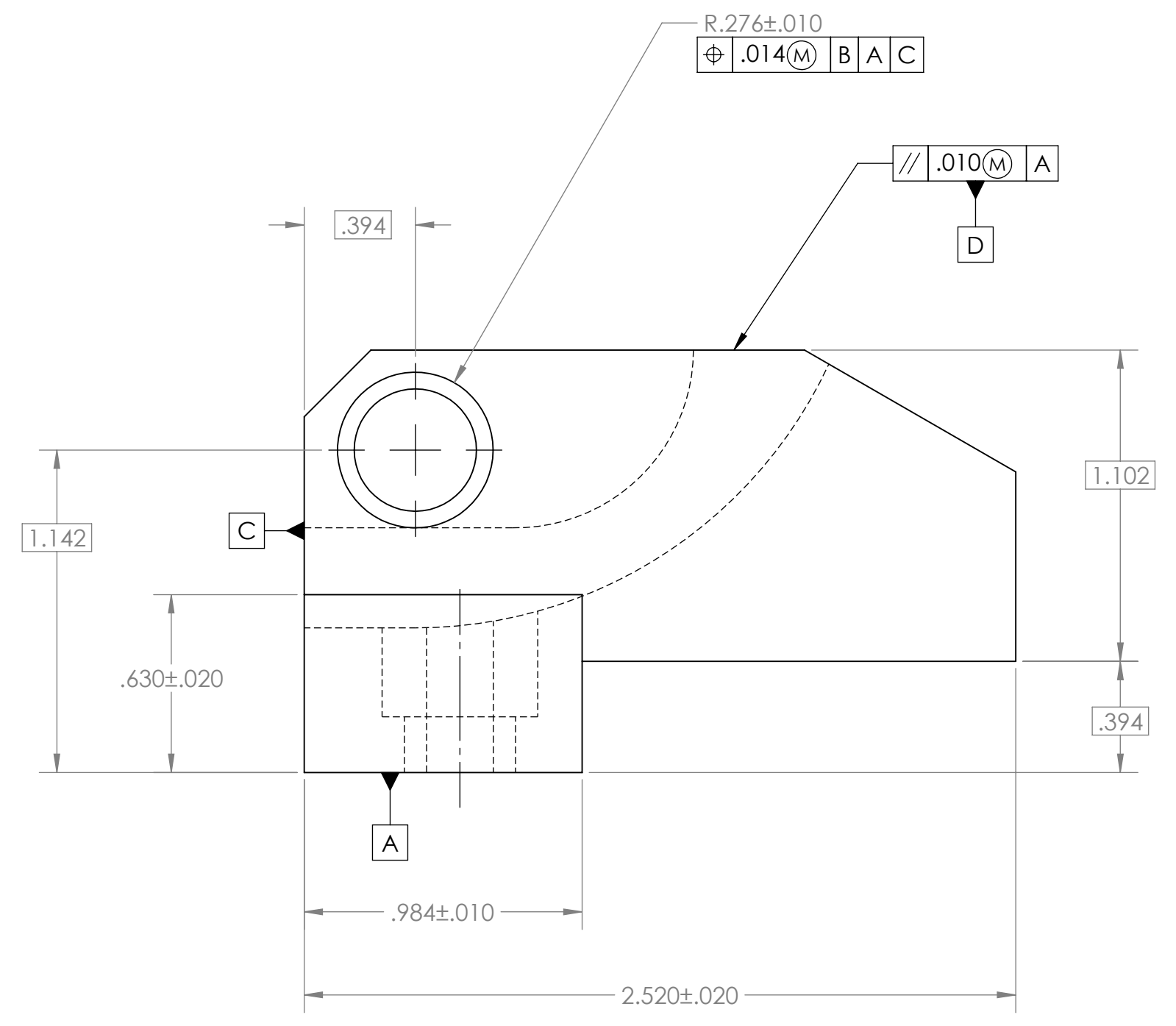
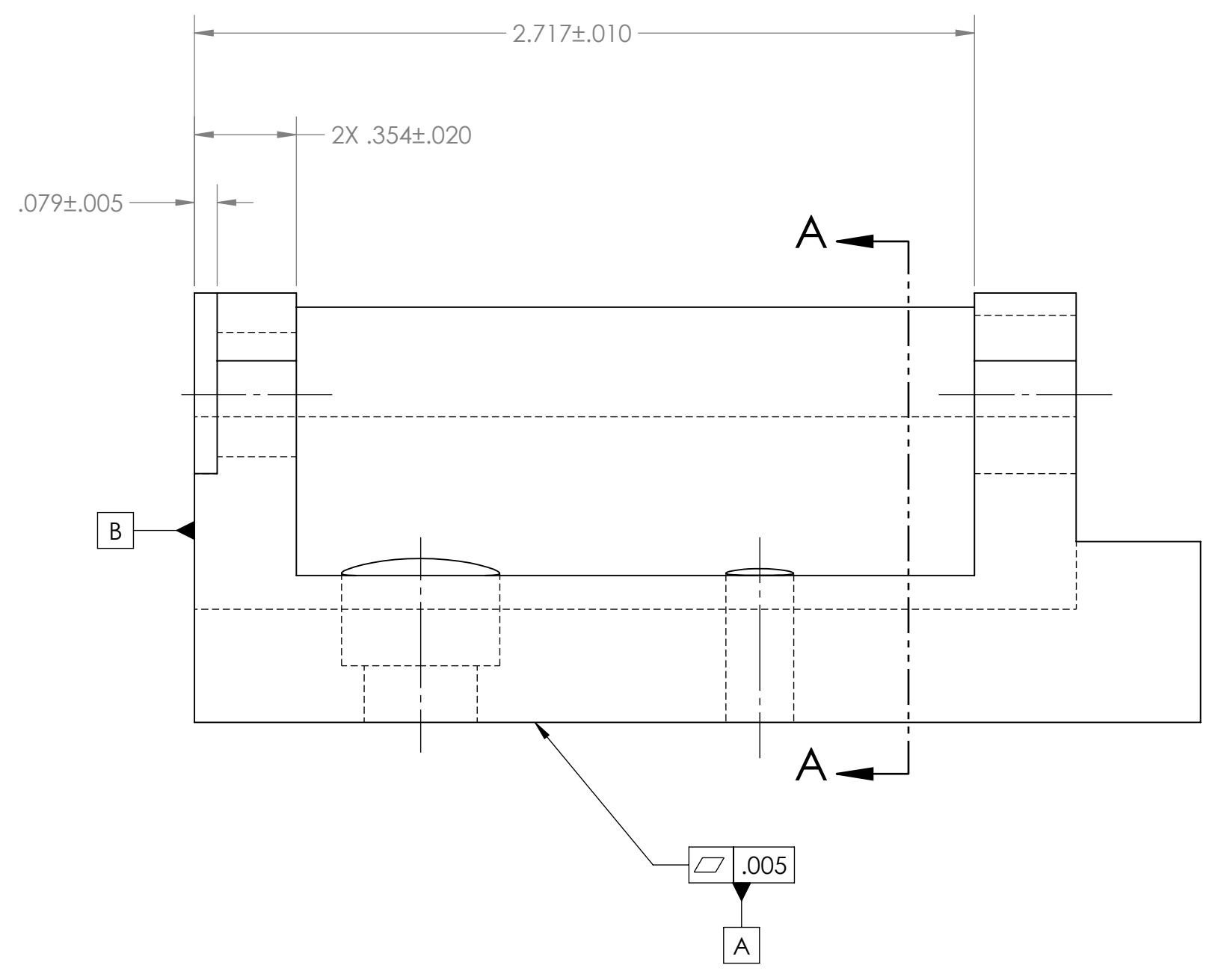
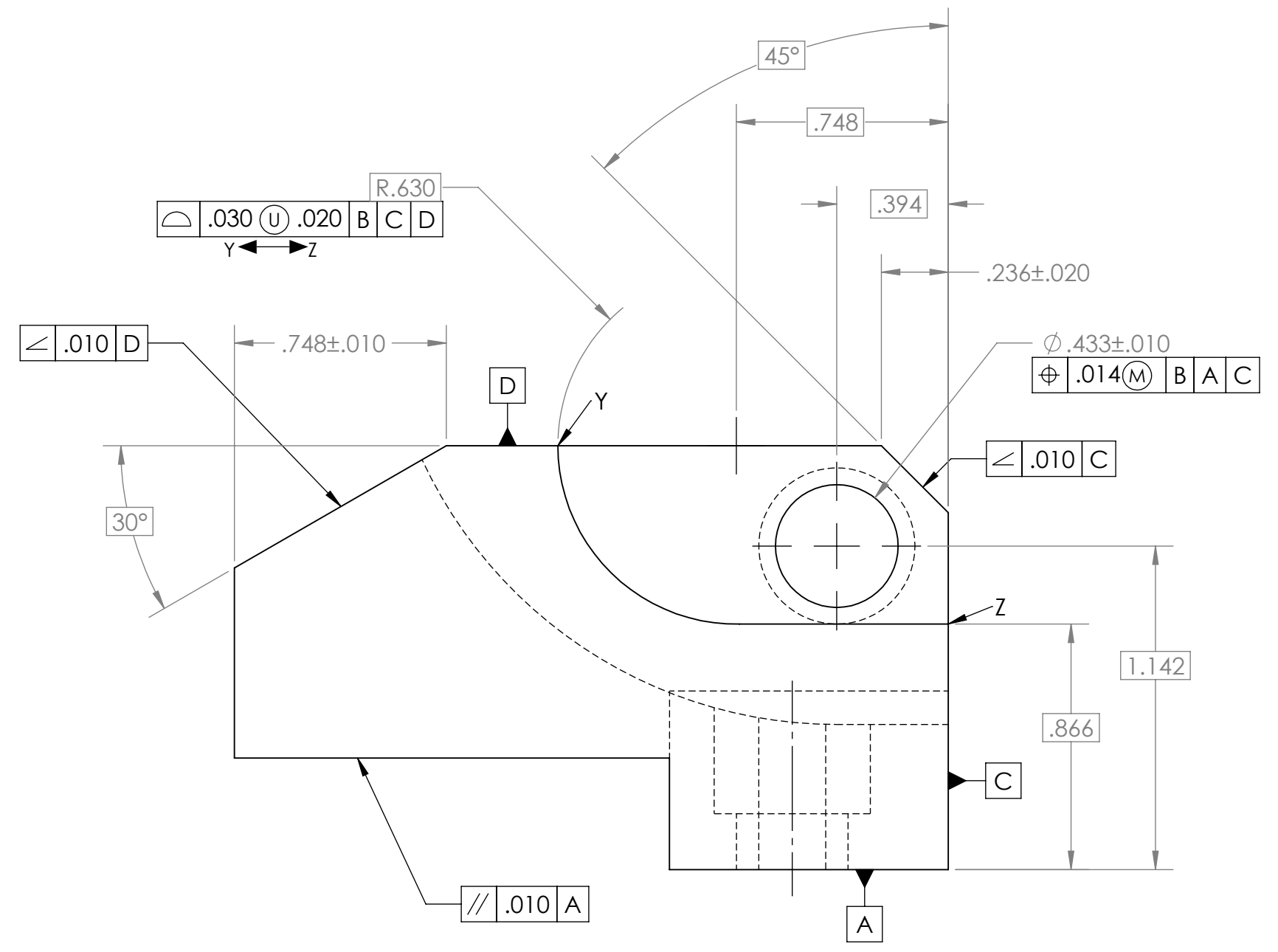
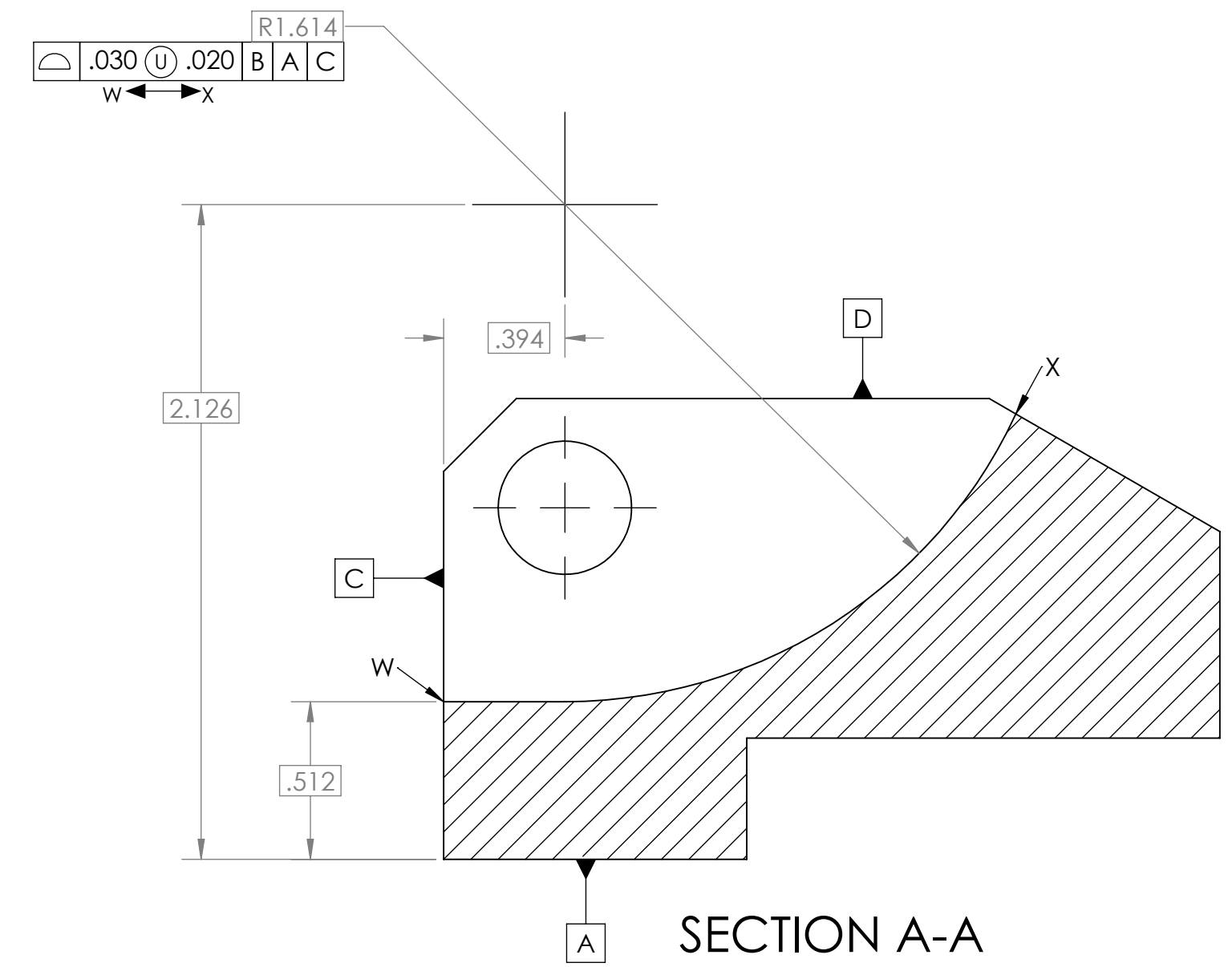
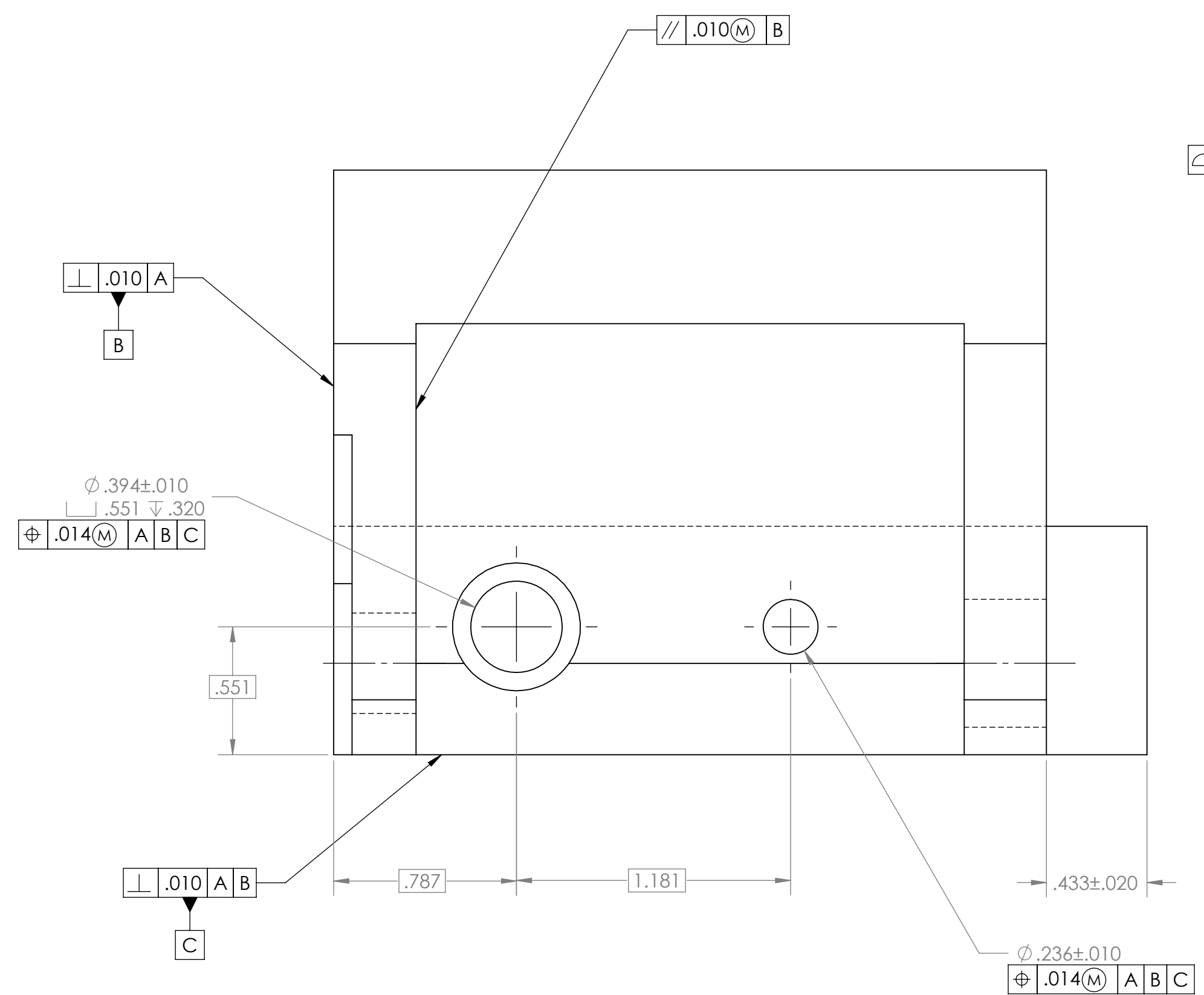

PROPRIETARY AND CONFIDENTIAL
THE INFORMATION CONTAINED IN THIS
DRAWING IS THE SOLE PROPERTY OF
LWTECH. ANY REPRODUCTION OR
DISSEMINATION OF THIS DRAWING
WITHOUT THE WRITTEN PERMISSION OF
LWTECH IS PROHIBITED.

UNLESS OTHERWISE SPECIFIED: DIMENSIONS ARE IN INCHES TOLERANCES: FRACTIONAL: 1/32 ANGULAR: MACH ± .25° BEND ± 5° TWO PLACE DECIMAL ± .02 THREE PLACE DECIMAL ± .010	DRAWN MV	DATE 02/22/24	LWTECH TITLE: 21.8 - TAKE #1
INTERPRET GEOMETRIC TOLERANCING PER: ASME Y.14.5-2018 AND MILL-T-31000	CHECKED ENG APPR.		
MATERIAL: SAE 1060 ALLOY	Q.A. COMMENTS:		SIZE DWG. NO. D EXERCISE 21.8
FINISH: DO NOT SCALE DRAWING			REV - SCALE: 2:1 WEIGHT: SHEET 1 OF 1