

REVISIONS				
ZONE	REV.	DESCRIPTION	DATE	APPROVED

CAD MAINTAINED.
CHANGES SHALL BE
INCORPORATED BY
THE DESIGN
ACTIVITY.

NOTES: UNLESS OTHERWISE SPECIFIED:

1. INTERPRET DRAWING IN ACCORANCE WITH INDUSTRY STANDARDS PRESCRIBED BY ASME Y.14.5-2018 AND MILL-T-31000.
2. MATERIAL: 1060 ALLOY.
3. ALL FILLETS AND ROUNDS R.125.
4. REMOVE ALL BURRS AND SHARP EDGES.
5. SURFACE FINISH 120/

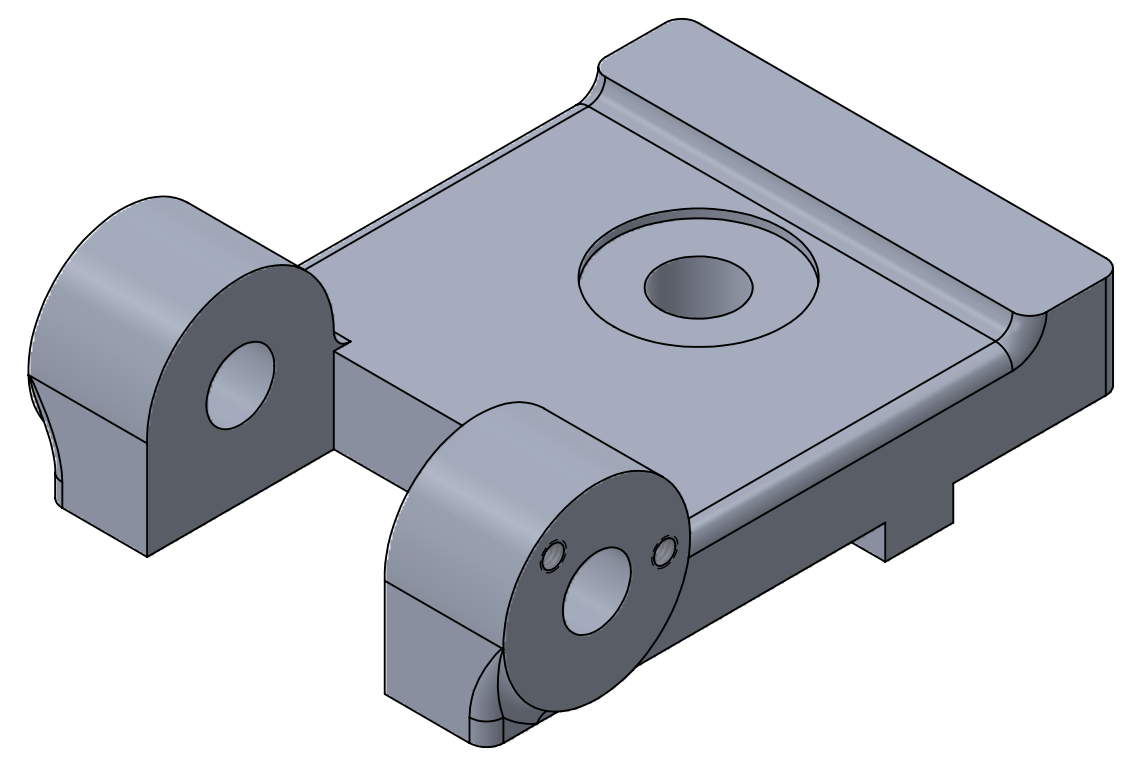
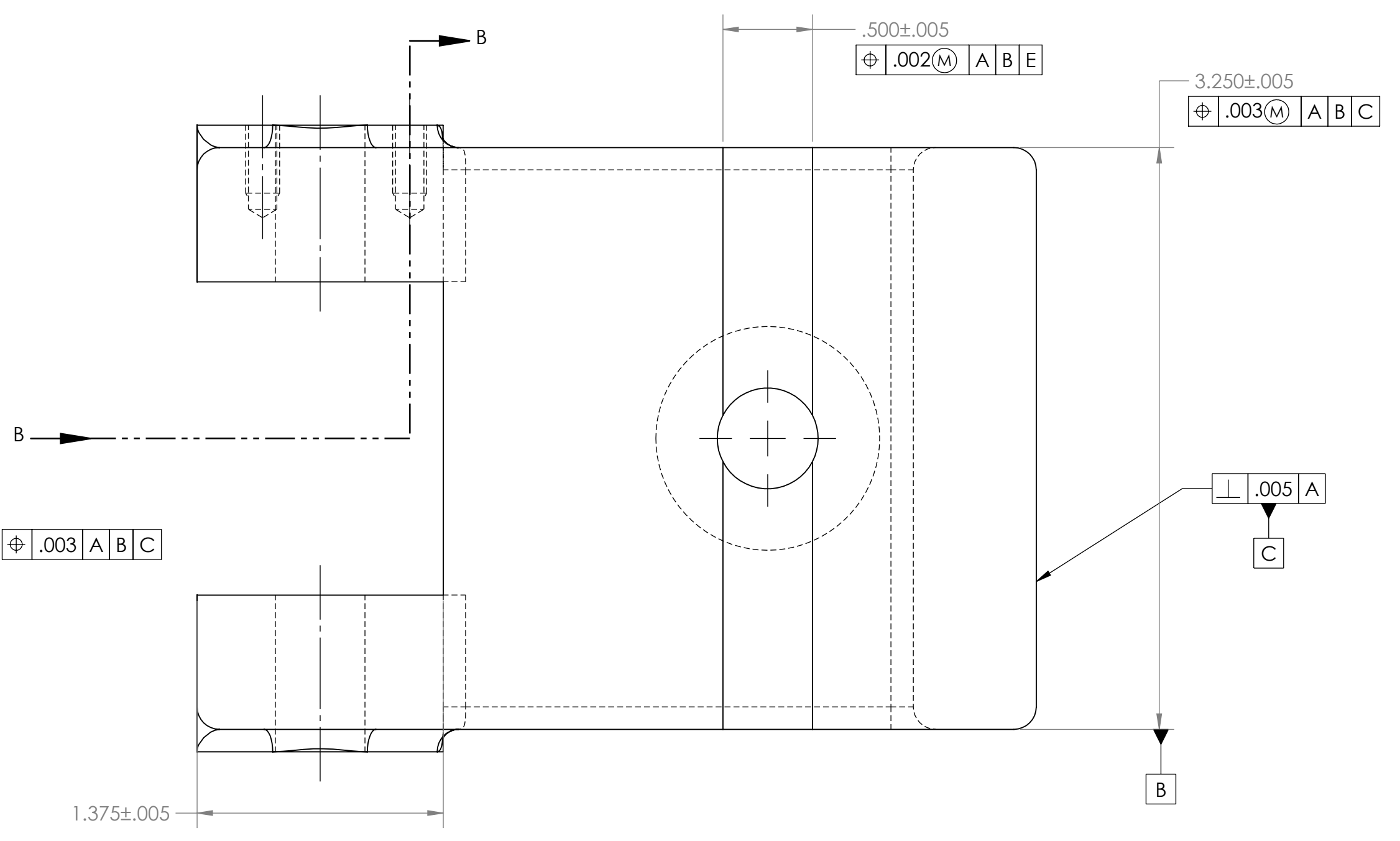
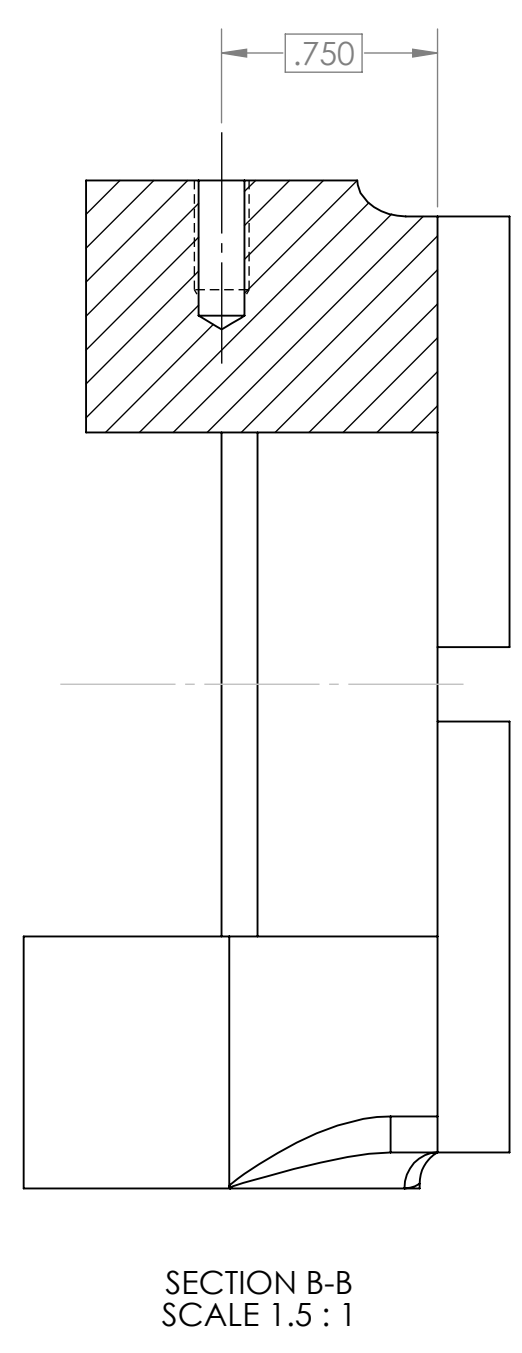
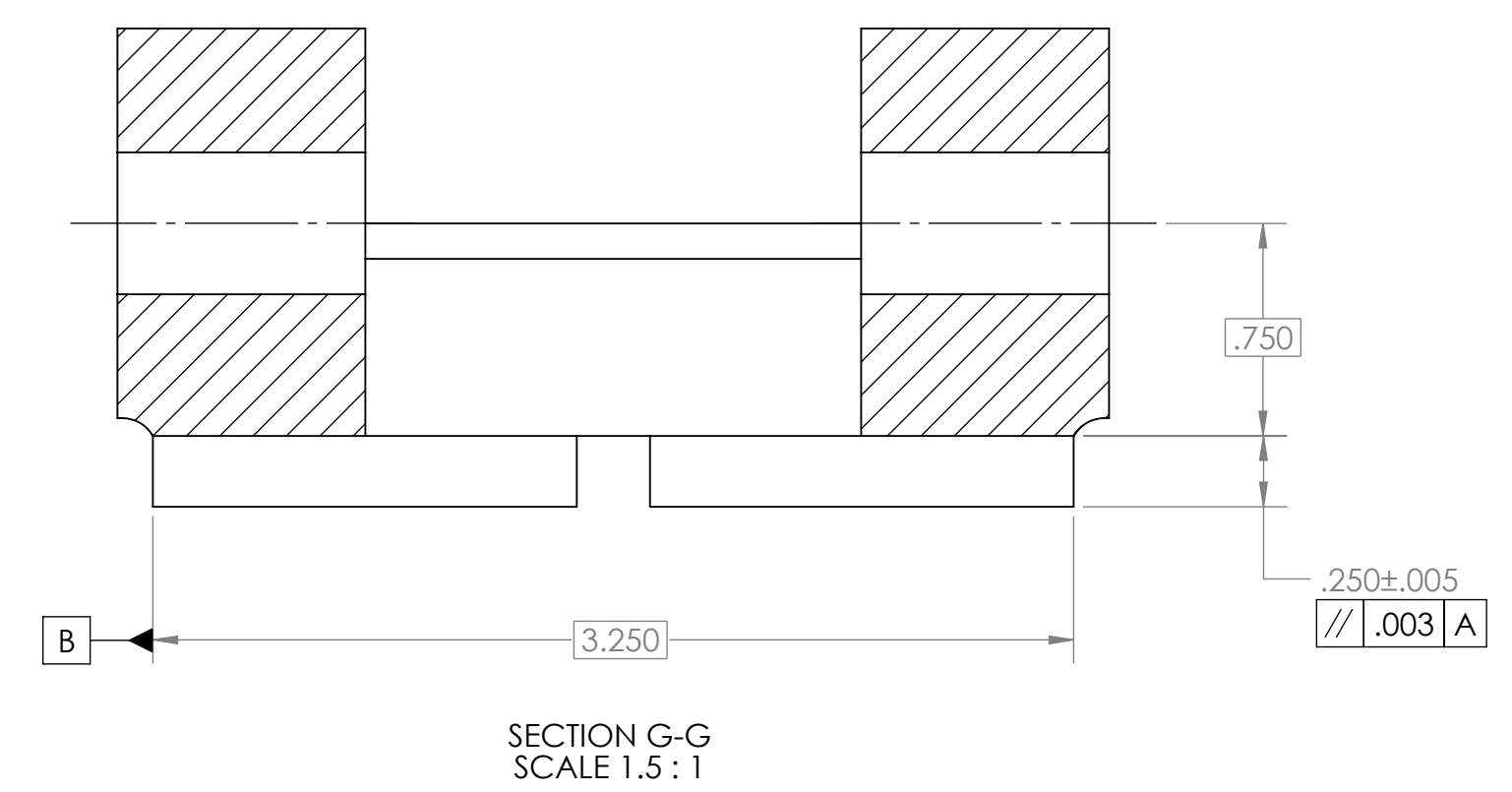
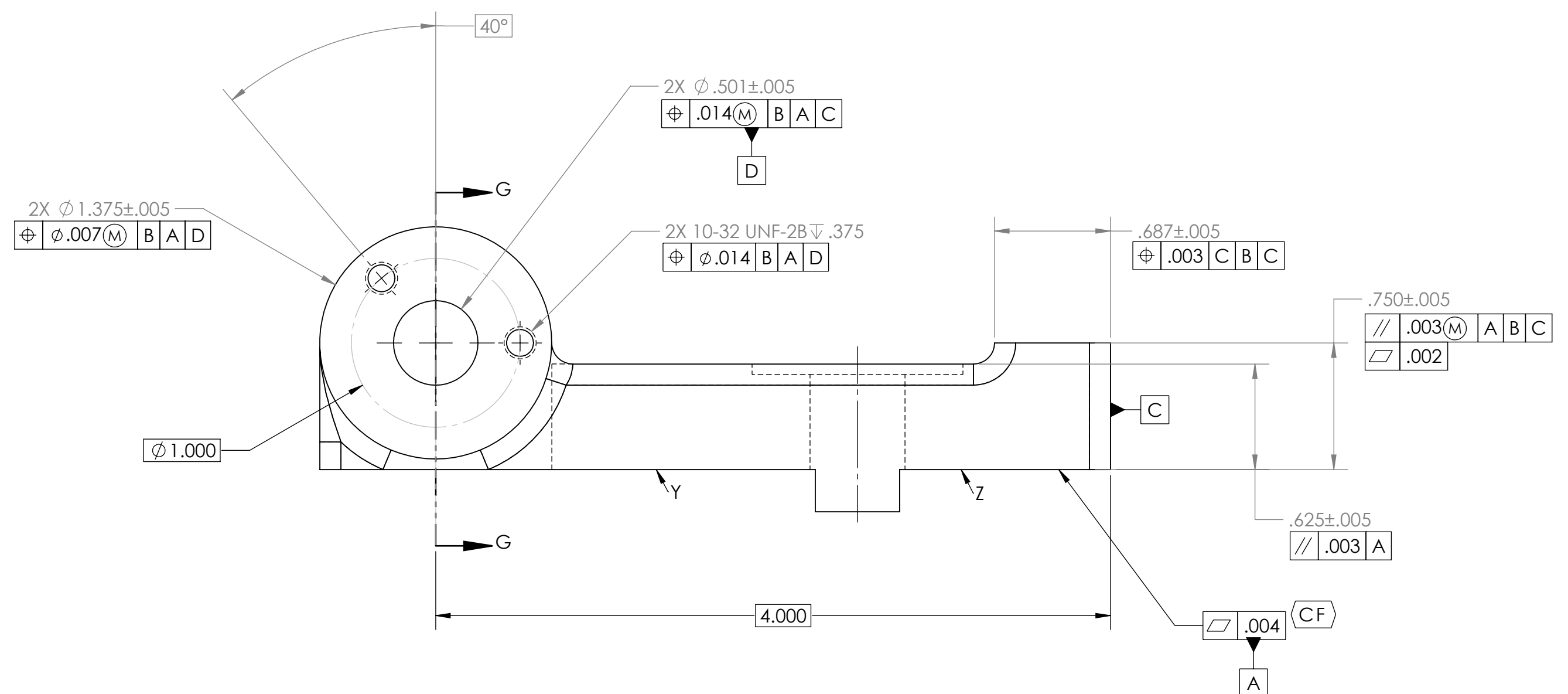
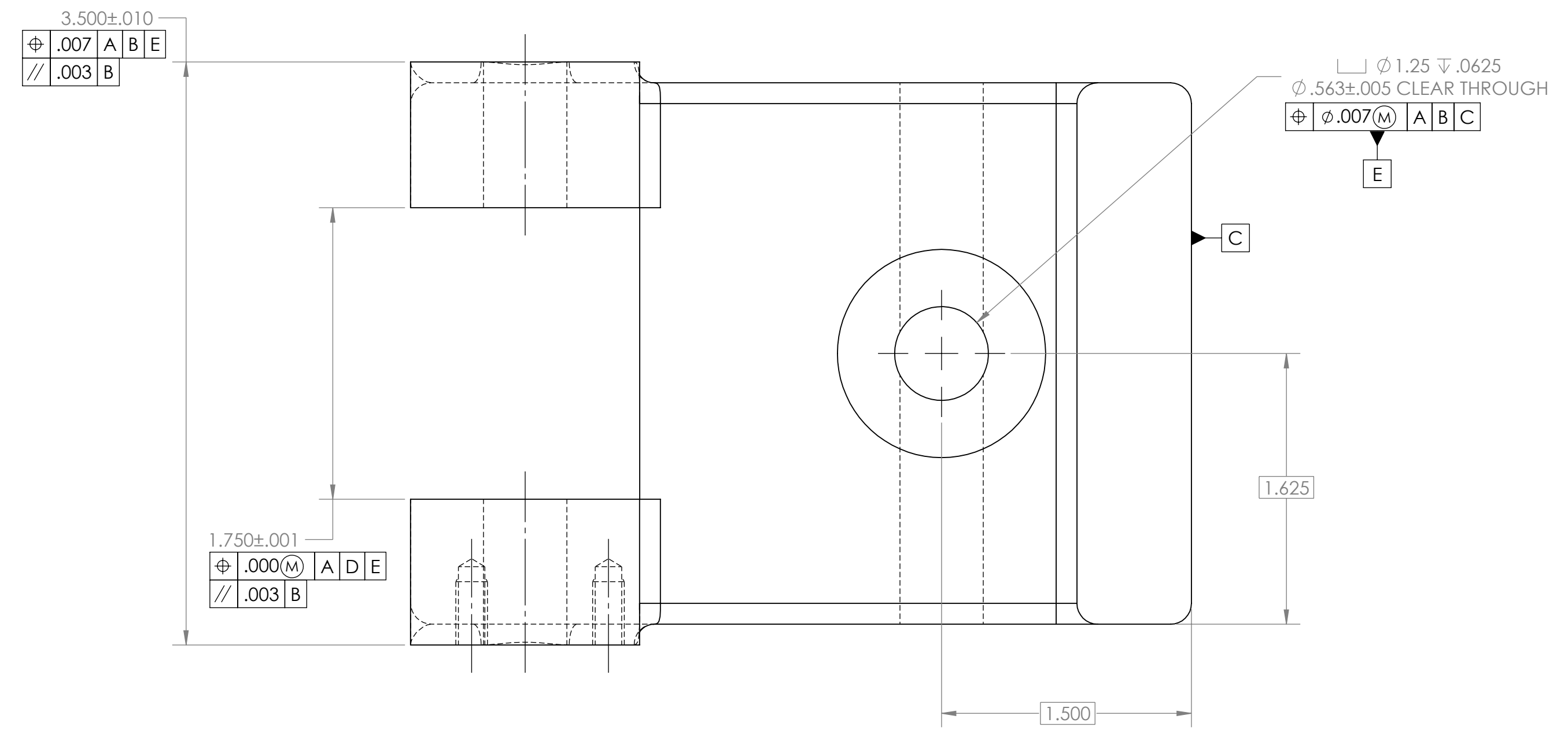

PROPRIETARY AND CONFIDENTIAL
THE INFORMATION CONTAINED IN THIS
DRAWING IS THE SOLE PROPERTY OF
«INSERT COMPANY NAME HERE». ANY
REPRODUCTION IN PART OR AS A WHOLE
WITHOUT THE WRITTEN PERMISSION OF
«INSERT COMPANY NAME HERE» IS
PROHIBITED.

UNLESS OTHERWISE SPECIFIED:		NAME	DATE
DIMENSIONS ARE IN INCHES	DRAWN	MV	10/14/23
TOLERANCES:	CHECKED		
FRACTIONAL: 1/64	ENG APPR.		
ANGULAR: MACH ± 1 DEG	MFG APPR.		
TWO PLACE DECIMAL ± .01			
THREE PLACE DECIMAL ± .005			
INTERPRET GEOMETRIC TOLERANCING PER:	Q.A.		
MATERIAL:	COMMENTS:		
1060 ALLOY			
FINISH:			
DO NOT SCALE DRAWING			

TITLE: **BASE, HINGE**

SIZE DWG. NO. REV
D MV-14-52-5 -

SCALE: 1.5:1 WEIGHT: .96 LBS SHEET 1 OF 1