

Autodesk AutoCAD 2020

Revisions				
Zone	Rev	Description	Date	Approved

NOTES: UNLESS OTHERWISE SPECIFIED

- INTERPRET DRAWING IN ACCORDANCE WITH INDUSTRY STANDARDS PRESCRIBED BY ANSI Y14.5 AND MIL-T-31000.
- MATERIAL: 5052-H34, ALUMINUM ALLOY
- FINISH: CHEM FILM PER MIL-T-5541.
- REMOVE ALL BURRS AND SHARP EDGES.
- FILLETS AND ROUNDS, R.500
- RUBBERSTAMP PART NUMBER (.12 MAX. HEIGHT) USING STANDARD GOTHIC LETTERS AND NUMBERS WITH PERMANENT MARKING INK. LOCATION OPTIONAL OR LOCATED AS SHOWN
- SURFACE ROUGHNESS 125
- DO NOT SCALE DRAWING

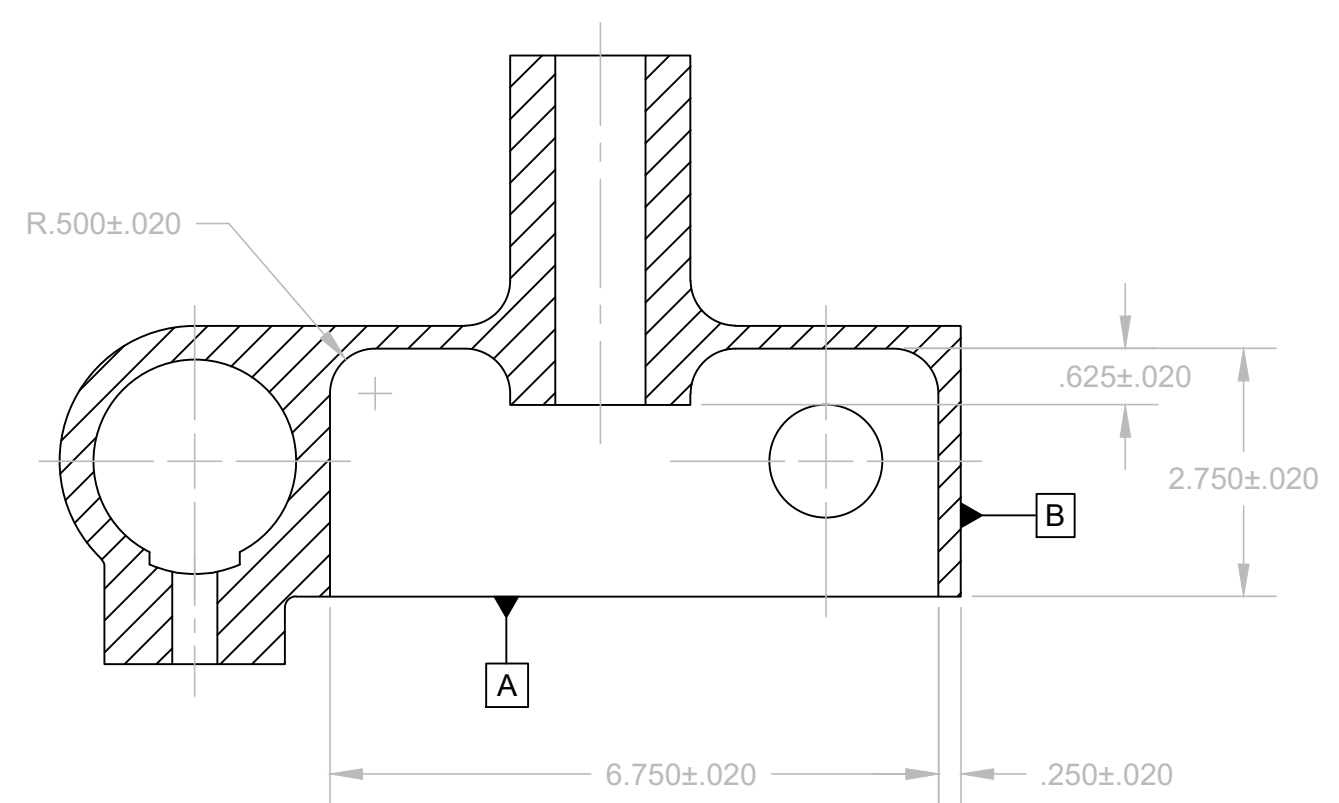

SECTION A-A SCALE 1:2

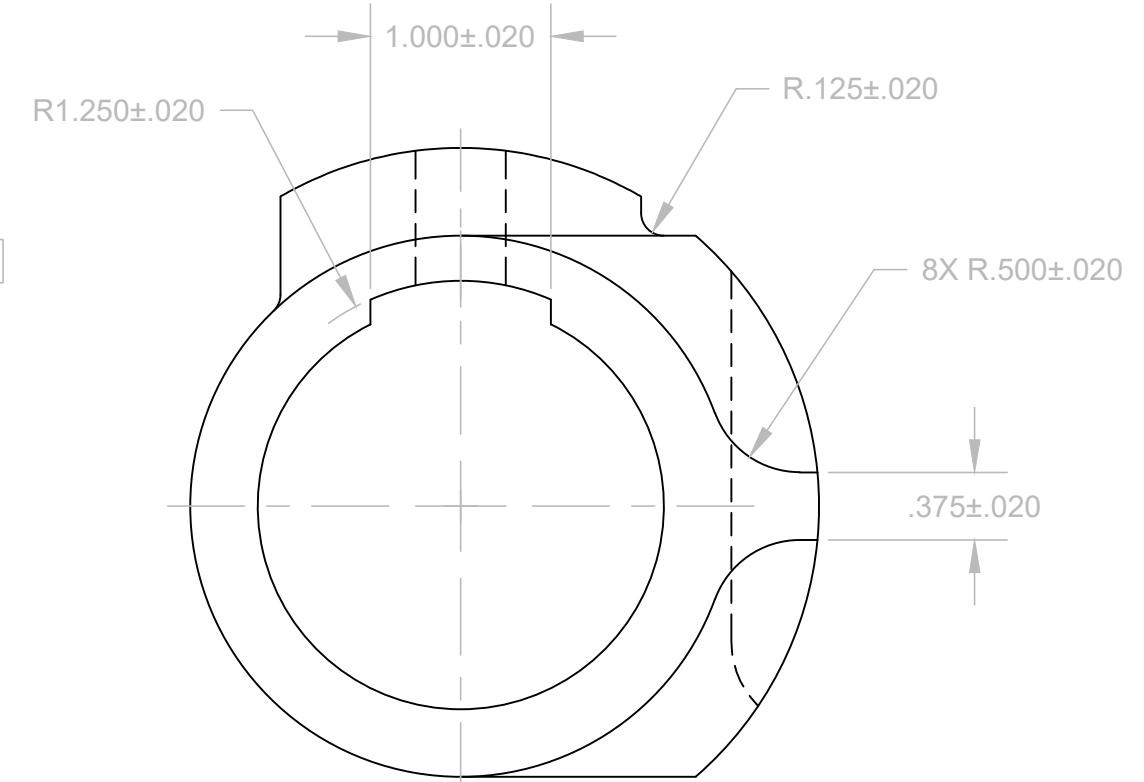
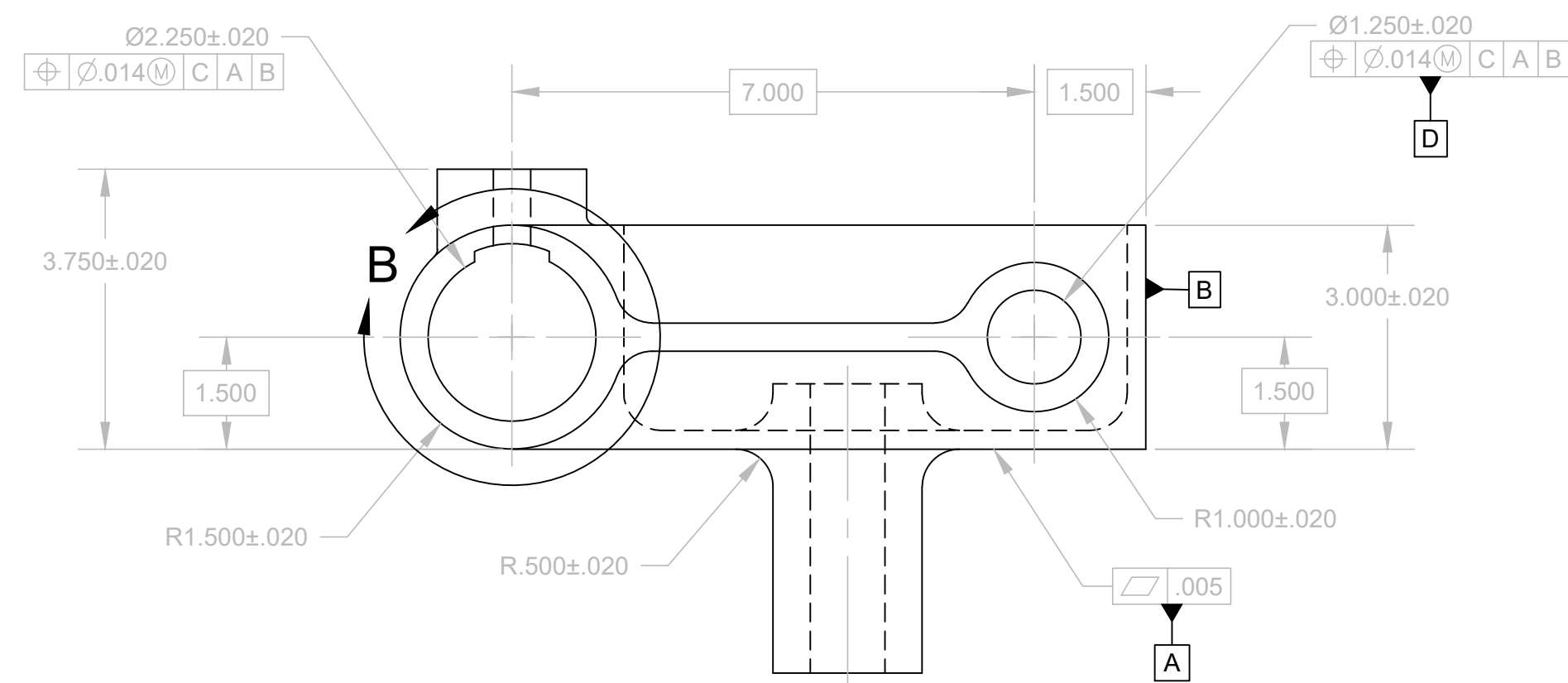
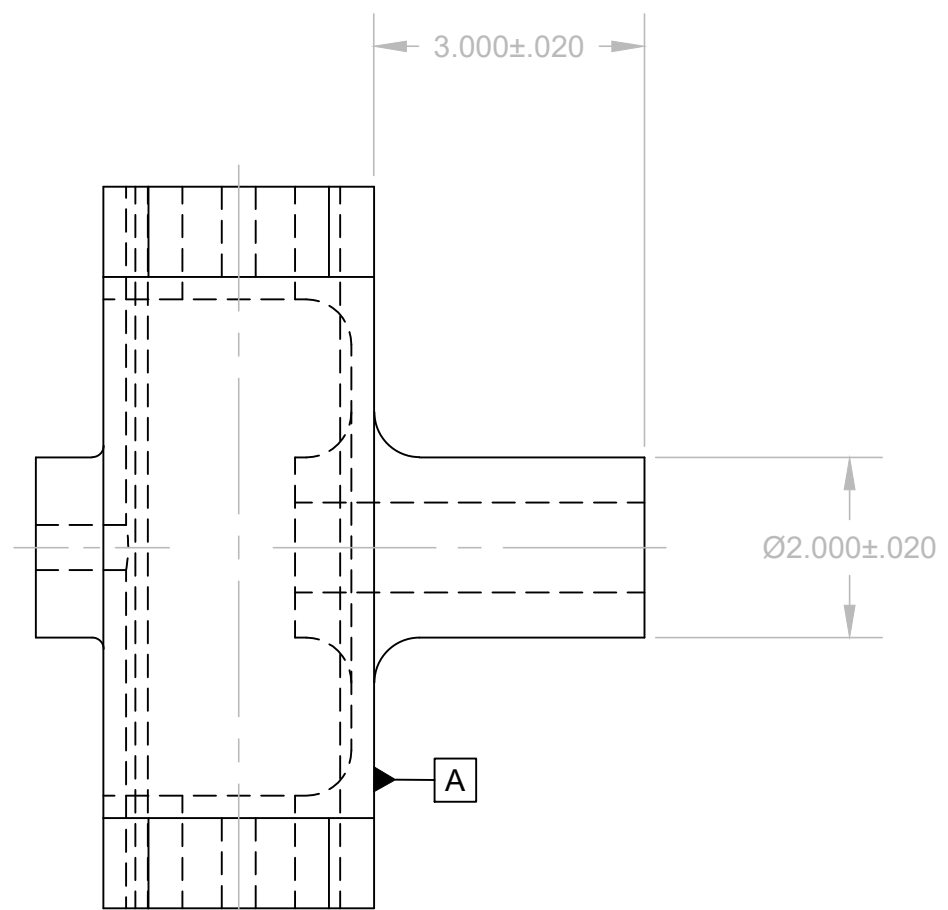
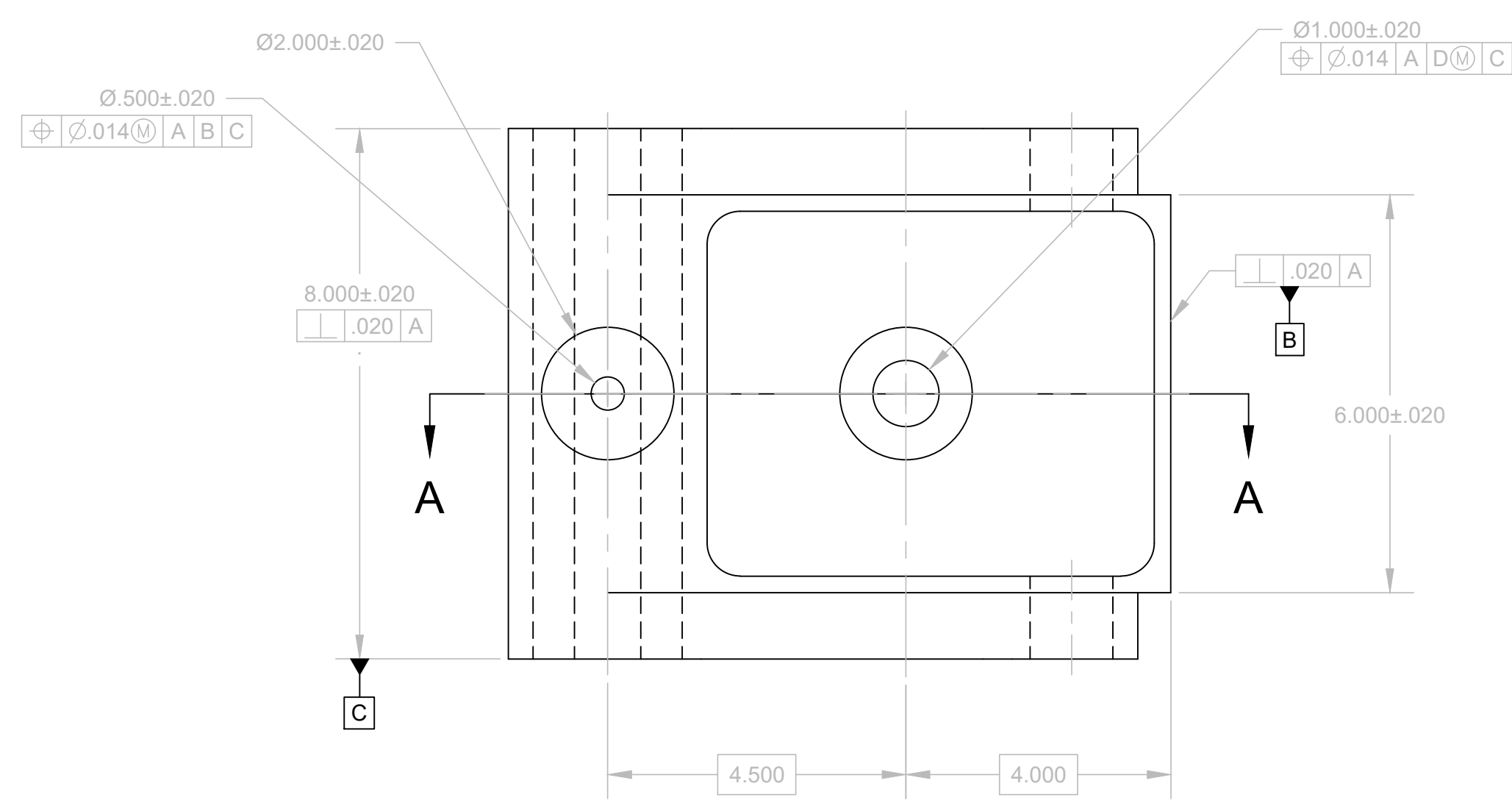

DETAIL B SCALE 1:1

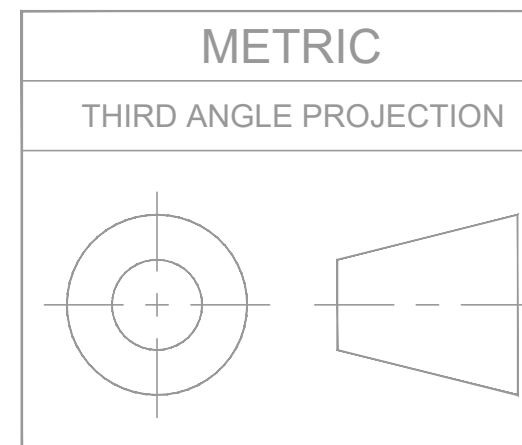
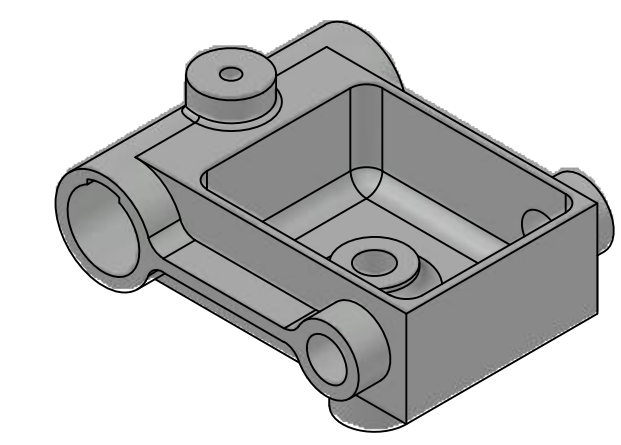

Qty	Req'd	Part or Identifying No.	Nomenclature or Description	Material Specification	Zone	Item Number

Contract Number: ENGT 271		LAKE WASHINGTON INSTITUTE OF TECHNOLOGY 11605 132nd AVE NE - Kirkland, Washington 98304 lwtech.edu			
Approval	Date	<h1>GEAR BOX</h1>			
Drawn By: M. VILLABLANCA	04/03/2024				
Checked By:					
Approved By: A. SHORT	04/03/2024	Size: D	Cage Code:	Drawing Number: 1-1	Revision: -
Plot Date: April 5, 2024	Scale: 1:1	AutoCAD 2020		Sheet Number: 123	