

VALMATIC®

Engineering Catalog

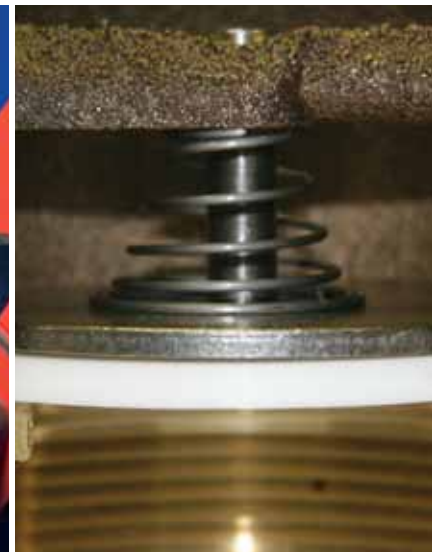

*Quality Valves
For Municipal
and Industrial
Applications*

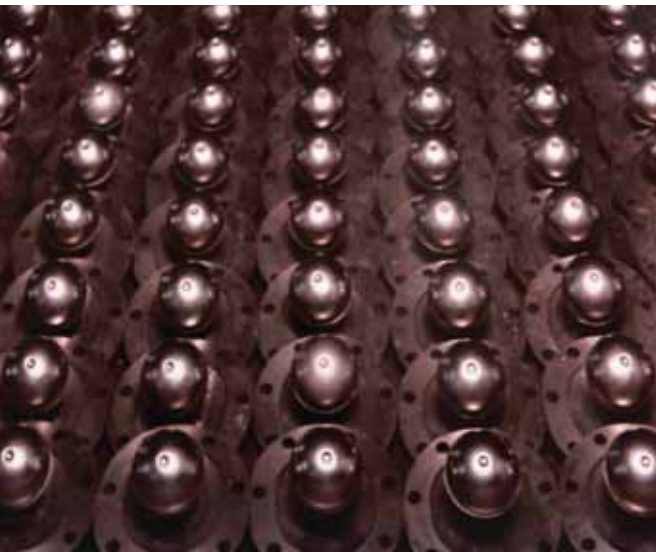

Your Valve Experts™

www.valmatic.com



Air Valves

Check Valves

Shut-Off Valves

Products.....	Pages
Section 1: Val-Matic Valve Capabilities	
Our Mission.....	3
Innovation and Technology	4-5
Section 2: Air Valves	
Air Release, Air/Vacuum and Combination.....	7-25
VaultSafe® Products	26-29
Section 3: Check Valves	
Swing-Flex® Check Valves	31-37
Surgebuster® Check Valves.....	39-45
Surgebuster® NXT Check Valves	47-49
Silent Check Valves	51-57
Swing Check Valves.....	59-69
Tilted Disc® Check Valves	71-85
Dual Disc® Check Valves	87-93
Sure Seal Foot Valves	95-97
Section 4: Shut-Off Valves	
American-BFV® Butterfly Valves	99-109
American-BFV® Butterfly Valves - High Performance..	111-115
Cam-Centric® Plug Valves - Std. Port.....	117-127
Cam-Centric® Plug Valves - 100% Port	129-139
Ener•G® Ball Valves	141-151
QuadroSphere® Ball Valves	153-171

Our Mission & Core Values

The mission of Val-Matic is to be recognized as the leader in our industry by profitably providing products and services that always meet or exceed the needs of our customers as they relate to quality, cost, performance, dependability, operational features and delivery considerations.

Val-Matic's Core Values

- Leadership
- Quality Products
- Continuous Improvement
- Loyalty



Elmhurst, IL Facility



Addison, IL Facility

History of Growth

From humble beginnings in 1966 with a silent check valve product line, Val-Matic Valve & Mfg. Corporation has grown to become a leading manufacturer of fourteen valve product lines for the water and wastewater, industrial, commercial building construction, and plumbing industries. Customers and users include sales representatives, OEM's, distributors, general contractors, municipalities, private water companies, and a variety of industrial users. Val-Matic operates two manufacturing facilities in Illinois, has strong working relationships with several independent factories, and deploys sales and marketing resources across the globe.

Val-Matic's success has been driven by manufacturing and product innovations to enhance reliability and quality; specific product features to meet the demands of diverse industries; and the development of a broad array of air valves (air vent valves), check valves, and quarter-turn valves. Backed by decades of product and application experience, Val-Matic continues to provide new developments in valve technology to serve industry through research and development. In 2014, Val-Matic completed a new 7,000 sq. ft. research and development facility in its manufacturing facility located in Addison, Illinois.



Materials Lab

The R&D facility includes a Materials Lab with state of the art equipment for testing elastomers and metals to determine their mechanical properties when exposed to corrosive environments and elevated temperatures.

A Flow Lab equipped with a battery of water pumps is used to perform dynamic valve tests and water flow tests in a wide range of pressures and velocities to determine flow and torque characteristics of various valves. Valve test data is recorded and analyzed using a computer based data acquisition system. In addition, a 5,000 gallon air tank allows full scale air flow testing of large air valves.



Flow Lab

The facility includes working models of pump control systems for use in technical hands-on training of industry professionals. Val-Matic is committed to developing superior quality products based on these expanded research and development resources.

Respected worldwide for quality products, Val-Matic utilizes the latest design and manufacturing technology coupled with close attention to industry requirements. The application of the latest product innovations while maintaining the highest quality products requires the seamless incorporation of advanced technologies in every step of design and manufacturing.



Coordinate Measuring Machine provide 3D data



Computer-Controlled Robotic Welding Station

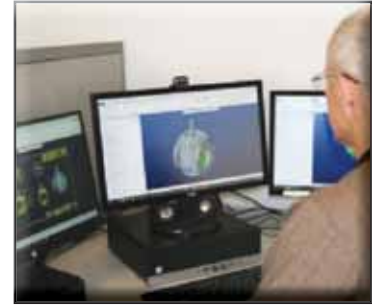

Computer Analysis using FEA and CFD Tehnology

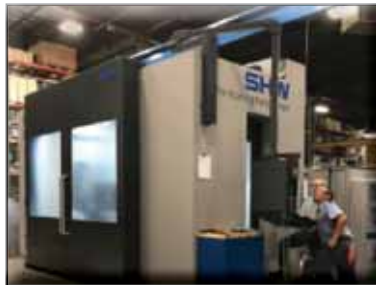

Multi-Axis Machine Cells with Automatic Tool Calibration



Dual Hydraulic Test Stand



3-D Printer provides scaled prototypes and models



X-Ray Fluorescence Scanner provides Positive Material Identification (PMI)



Automated Electrostatic Fusion Bonded Epoxy Process

Commitment to Quality

Val-Matic is an ISO 9001 certified company with products certified to applicable regulations and standards including NSF/ANSI 61 for drinking water and 372 Lead-Free; UL and FM for fire protection applications; and ASME, NACE, MSS, and API for other industries.

An experienced engineering staff takes a leading role in standard development organizations to keep published product standards current with industry innovations and user needs. Val-Matic engineers are leaders in the development of valve application software to assist users in selecting the right equipment for their fluid system.

Val-Matic's quality of design and meticulous workmanship have set the standard by which all others are measured. Val-Matic is totally committed to providing the highest quality products and services to its customers.



Air Valves are hand assembled and tested per AWWA Standards.



VAL-MATIC®



Air Valves & VaultSafe® Family of Products



Meets AWWA C512 & C514
NSF/ANSI 61 & 372 Certified

Experience

Val-Matic offers over 50 years of experience in providing a full line of air valves up to 20 inch and vacuum breakers up to 42 inch in size. The Val-Matic Air Release, Air/Vacuum and Combination Air Valves are manufactured in accordance to the rigorous industry requirements given in American Waterworks Association (AWWA) Standard C512. The standard was developed and based on decades of successful applications of air valves in our industry. Val-Matic's AWWA Air Valves feature 316 stainless steel trim, full size ports, ANSI threaded or flanged connections and stringent testing. From the float material to the shape of the body, Val-Matic Air Valves are designed for optimum performance. Val-Matic manufactures air valves in a wide range of materials and pressure ratings with many accessories including Regulated-Exhaust Devices, Dual Port Throttling Devices, Isolation Valves, Screened Hoods and Backwash Accessories. Val-Matic also provides web-based software to locate, select and size air valves for pipelines and force mains.

Type 316 Stainless Steel Trim

Type 316 stainless steel is the standard for all internal components in Val-Matic Air Valves. Type 316 stainless steel provides the greatest protection from aggressive waters and hydrogen sulfide exposure in wastewater applications.

Unconditionally Guaranteed Floats

Floats are unconditionally guaranteed for the life of the valve from corrosion, collapse or leakage. Val-Matic has such confidence in the design and manufacturing of our floats that we are able to provide this unconditional guarantee.

Guided Floats

Providing a quality float is not enough to ensure a reliable seal every time. When entering the seat, a damaged or off-center float will prevent a valve from sealing tight. The high air and water velocities in air valves can cause unguided floats to violently strike the sides of the valve body. Val-Matic air/vacuum floats are guided with hexagonal stems in round bushings to prevent the build-up of debris or scale. Guiding assures

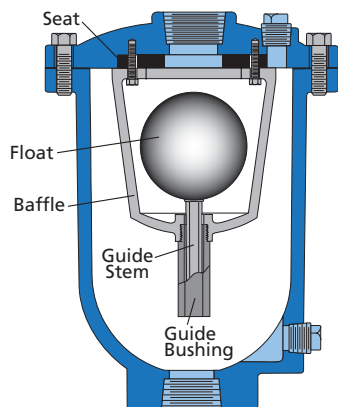

that the float approaches the center of the seat every time to provide a positive drop tight seal.

Resilient Seats

All Val-Matic valves incorporate a resilient seat or orifice button which mates with a 316 stainless steel float or seat for positive drip tight seating. Val-Matic elastomers are specially formulated for water and wastewater service and have been NSF 61 certified. Air Release Valves have a synthetic sealing button mounted to the float linkage mechanism. On Air/Vacuum and Combination Air Valves, the stainless steel float closes against the resilient seat mechanically retained in a cover register. The seats contain raised sealing beads that provide positive shutoff from the lowest system pressure to the valve's rated working pressure.

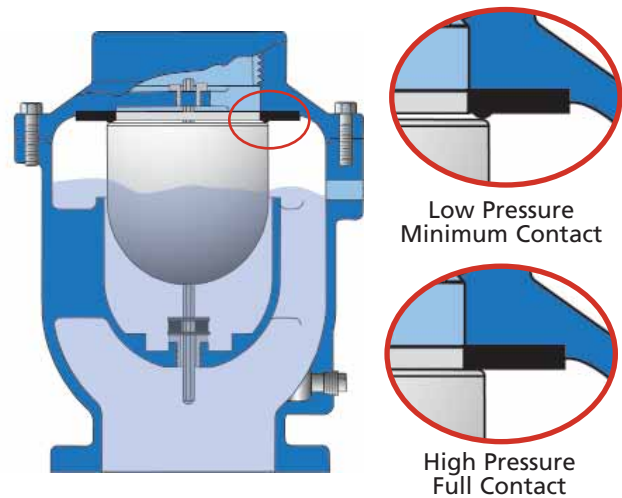

Pressure Sensitive Seating with Raised Sealing Beads

Full Size Flow Area

Val-Matic Air/Vacuum and Combination Air Valves are equipped with full and equal size inlets and outlets in accordance with AWWA C512. Some air valve manufacturers use common covers for different size air valves resulting in undersized outlets and reduced flow. Standard industry calculations assume a full port size so the air valve should provide the same. You can be assured that the inlets and outlets of Val-Matic's Air Valves are equal to or larger than the area of the nominal valve size. Finally, all Combination Air Valves with float guides in the outlet have expanded flow areas around the guide spokes to provide full flow area through the valve.

Certifications

Val-Matic Air Valves for water service are NSF 61 and 372 certified and marked for use in drinking water applications. All Air Valves meet AWWA C512 requirements.

Stainless Steel Body

Seamless stainless steel bodies are lightweight and available for extreme service such as hydrogen sulfide, industrial chemicals or corrosive environments. ASTM A351, Grade CF8M stainless steel bodies provide superior corrosion resistance in full compliance with AWWA C512.

Non-Stick Coatings

Special interior coatings are available to minimize the buildup of sewage on the inside of the valve. Val-Matic's Fusion Bonded Epoxy is a baked-on, glass-like coating that reduces maintenance and prevents corrosion of the valve. Non-stick coatings are important when force mains contain grease that tends to collect in valves and pipes.

Non-Clog Design for Reduced Maintenance

Val-Matic Wastewater Air Valves are specially designed for grit and sewage service without the need for backwashing when combined with non-stick coatings. The bodies are extended in length to prevent solid material from reaching the operating mechanism. The bottom of the body is sloped toward the outlet to prevent clogging. Val-Matic provides a minimum 2 inch inlet size and a 2 inch cleanout connection on all wastewater valves to facilitate the passage of solids.

Wastewater Floats

As with all Val-Matic Air Valves, the float and operating mechanism are 316 stainless steel for long life in the harshest wastewater applications. Additionally, the floats are equipped with a concave or skirted shaped bottom to accelerate the closure of the float to reduce leakage and clogging of the valve.

Severe Service Backwashing

When systems are heavy in grease and solids, backwashing of Wastewater Air Valves may become a necessary maintenance process. The key is to reduce the frequency of backwashing by designing the valve to handle conditions such as wastewater containing solids and grease. As indicated in the above features, Val-Matic has done that with the extended and bell shaped body, the sensitivity float and the availability of non-stick Fusion Bonded Epoxy. Periodic maintenance may still be required on severe applications, therefore, all Wastewater Air Valves can be furnished with an accessory kit which includes a shutoff valve to isolate the air valves from the line, flush and drain valves, and a hose for connecting to a clean water supply.

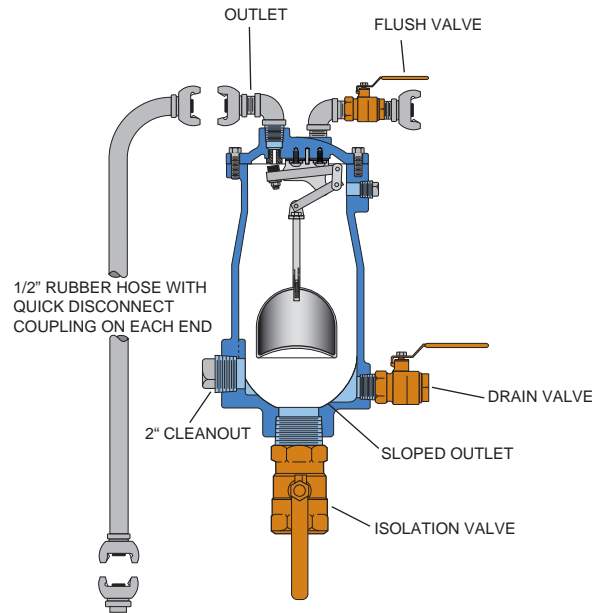

Air Valve with Severe Service Backwash Accessories

Backwashing is as simple as: 1) closing the isolation valve, 2) opening the drain valve, and 3) sending clean water through the flush valve and outlet for five minutes.

For those installations where backwashing on site is not practical or desirable, a valve rotation program can be established. The valve to be serviced is exchanged with a spare valve and taken back to the shop for cleaning. It is then ready to replace the next valve scheduled for maintenance. The valve rotation program also provides the benefit of a backup valve in the unlikely event one should ever fail.

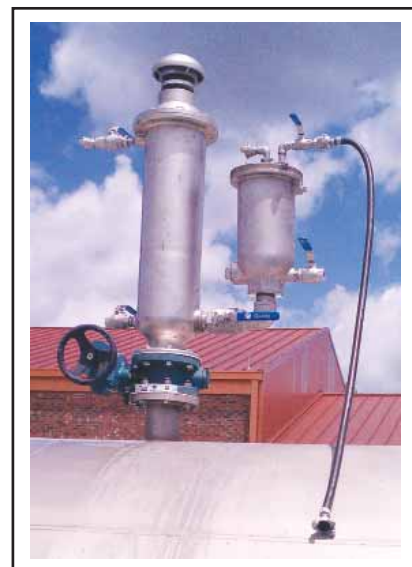

Stainless Steel Dual Body Wastewater Combination Air Valve

Air Release Valves



Operational Highlights:

- Maintains system flow efficiency
- Releases unwanted air pockets during system operation
- Protects system against air related surges
- Fully complies with AWWA C512

Product Features:

- Unconditionally guaranteed stainless steel floats
- Stainless steel 316 internal trim
- Resilient seating for positive shutoff
- Performance proven for over 50 years
- Non-clog design minimizes need for backwashing

Optional Accessories:

- Vacuum check (prevents inflow of air)
- Outlet hood with screen (prevents debris from entering valves)
- Ball and plug isolation valves (allows valve maintenance)
- Inflow Preventer on outlet (stops flood water and resulting contamination from entering pipeline)
- Backwash kit (for severe wastewater applications)

MATERIALS OF CONSTRUCTION		
COMPONENT	STANDARD	OPTIONAL
Body and Cover	Cast Iron ASTM A126 Class B Ductile Iron ASTM A536 Grade 65-45-12	Carbon Steel ASTM A216 Grade WCB Stainless Steel ASTM A351 Grade CF8M
Float and Trim	Type 316 Stainless Steel	-----
Seal	Buna-N	EPDM or Viton
Coating	Universal Acrylic Primer (external)	Non-Stick Fusion Bonded Epoxy (internal & external)

VENTING CAPACITY OF AIR RELEASE VALVE ORIFICES

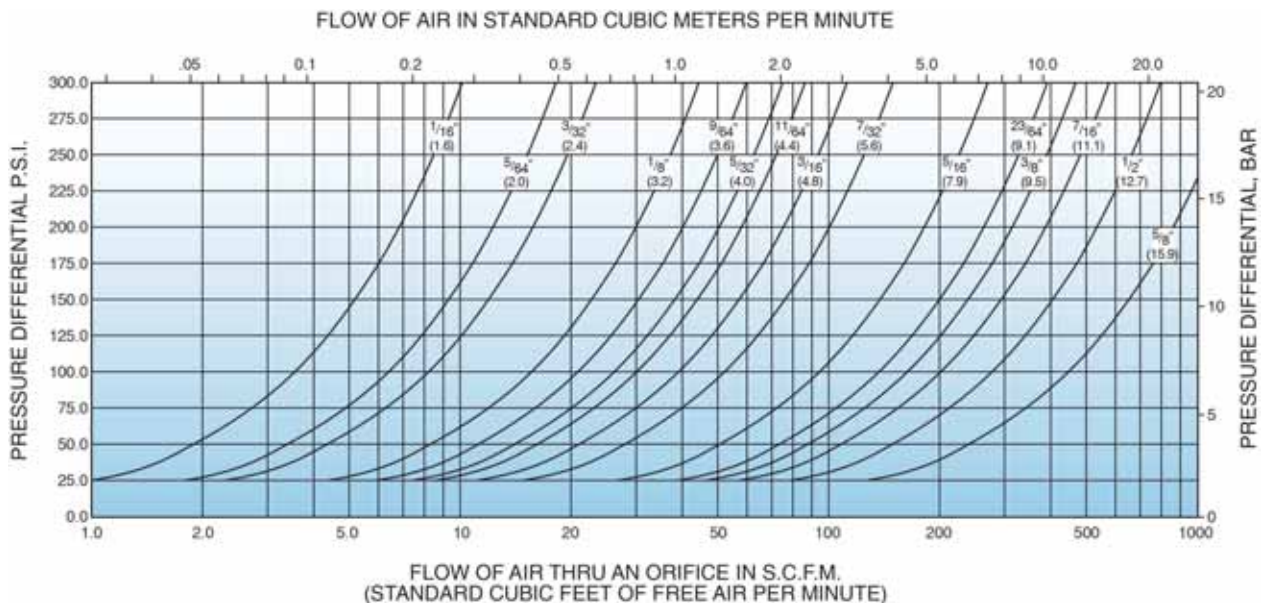

WATER AIR RELEASE VALVES						
Inlet Size	Outlet Size	Model Number*	CWP PSI	Orifice Size	Dimensions (Inches)	
					A	B
1/2" NPT	1/2" NPT	15A†	175	1/16"	4.75	5.25
3/4" NPT	1/2" NPT	15A.2†	175	1/16"	4.75	5.25
1" NPT	1/2" NPT	15A.3†	175	1/16"	4.75	5.25
1" NPT	1/2" NPT	22.3†	175	3/32"	5.13	6.31
1/2" - 3/4" NPT	1/2" NPT	22.4†	175	3/32"	5.13	6.31
1/2" NPT	1/2" NPT	22.7†	300	1/16"	5.13	6.31
3/4" - 1" NPT	1/2" NPT	22.9	300	1/16"	5.13	6.31
3/4" - 1" NPT	1/2" NPT	25.5	150	1/8"	6.13	7.00
3/4" - 1" NPT	1/2" NPT	25.6	300	3/32"	6.13	7.00
1" NPT	1/2" NPT	38	150	3/16"	7.00	10.00
2" NPT	1/2" NPT	38.2	150	3/16"	7.00	10.00
1" NPT	1/2" NPT	38HP	500	1/8"	7.00	10.00
2" NPT	1/2" NPT	38HP.2	500	1/8"	7.00	10.00
1" NPT	1/2" NPT	38.5	300	5/32"	7.00	10.00
2" NPT	1/2" NPT	38.6	300	5/32"	7.00	10.00
2" NPT	1" NPT	45	150	23/64"	9.50	12.25
3" NPT	1" NPT	45.2	150	23/64"	9.50	12.25
2" NPT	1" NPT	45HP	400	3/16"	9.50	12.25
3" NPT	1" NPT	45HP.2	400	23/64"	9.50	12.25
2" NPT	1" NPT	45.5	300	7/32"	9.50	12.25
3" NPT	1" NPT	45.6	300	7/32"	9.50	12.25
2" NPT	1" NPT	50	500	7/32"	10.88	13.06
2" NPT	1" NPT	50HP	1000	1/8"	10.88	13.06
6" 125lb Flg	1" NPT	61	150	1"	19.63	22.06

*NSF 61 & 372 Certified †UL Listed/FM Approved

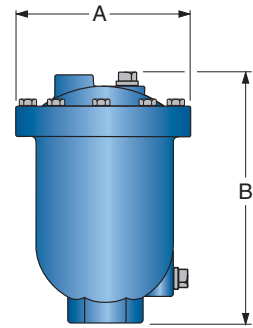

15A - 50HP
Air Release Valve

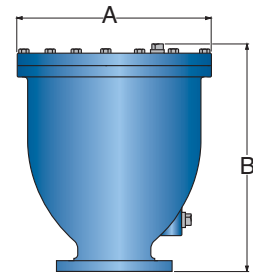

61
Air Release Valve

WASTEWATER AIR RELEASE VALVES						
Inlet Size	Outlet Size	Model Number	CWP PSI	Orifice Size	Dimensions (Inches)	
					A	B
2" NPT	1/2" NPT	48A	150	3/16"	7.00	15.31
3" NPT	1/2" NPT	48A.2	150	3/16"	7.00	15.31
2" NPT	1/2" NPT	48A.4	75	5/16"	7.00	15.31
3" NPT	1/2" NPT	48A.5	75	5/16"	7.00	15.31
4" NPT	1/2" NPT	48A.6	75	5/16"	7.00	15.31
2" NPT	1" NPT	49A	150	7/16"	9.50	17.56
3" NPT	1" NPT	49A.2	150	7/16"	9.50	17.56
2" NPT	1" NPT	49A.4	75	1/2"	9.50	17.56
3" NPT	1" NPT	49A.5	75	1/2"	9.50	17.56
4" NPT	1" NPT	49A.6	75	1/2"	9.50	17.56

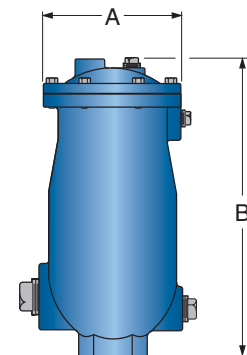

48A - 49A.6
Wastewater Air Release Valves



Clean Water



Wastewater

Operational Highlights:

- Exhausts large quantities of air at system start-up
- Provides pipeline vacuum protection
- Responds to loss of pressure during power failures, line breaks and intentional drainage
- Fully complies with AWWA C512

Product Features:

- Unconditionally guaranteed stainless steel floats
- Stainless steel 316 internal trim
- Exclusive high/low pressure resilient seating
- Full pipe size inlets and outlets provide maximum protection
- Non-clog design minimizes need for backwashing

Optional Accessories:

- Outlet hood with screen (prevents debris from entering valves)
- Flanged outlets on sizes 8 inch & smaller
- Ball and plug isolation valves (allows valve maintenance)
- Inflow Preventer on outlet (stops flood water and resulting contamination from entering pipeline)
- Backwash kit (for severe wastewater applications)

MATERIALS OF CONSTRUCTION		
COMPONENT	STANDARD	OPTIONAL
Body, Cover and Baffle	Cast Iron ASTM A126 Class B Class 125 and 250 Ductile Iron ASTM A536 Grade 65-45-12	Carbon Steel ASTM A216 Grade WCB Stainless Steel ASTM A351 Grade CF8M
Trim	Type 316 Stainless Steel	-----
Seal	Buna-N	EPDM or Viton
Coating	Universal Acrylic Primer (external)	Non-Stick Fusion Bonded Epoxy (internal & external)

VENTING CAPACITY OF AIR/VACUUM VALVE ORIFICES

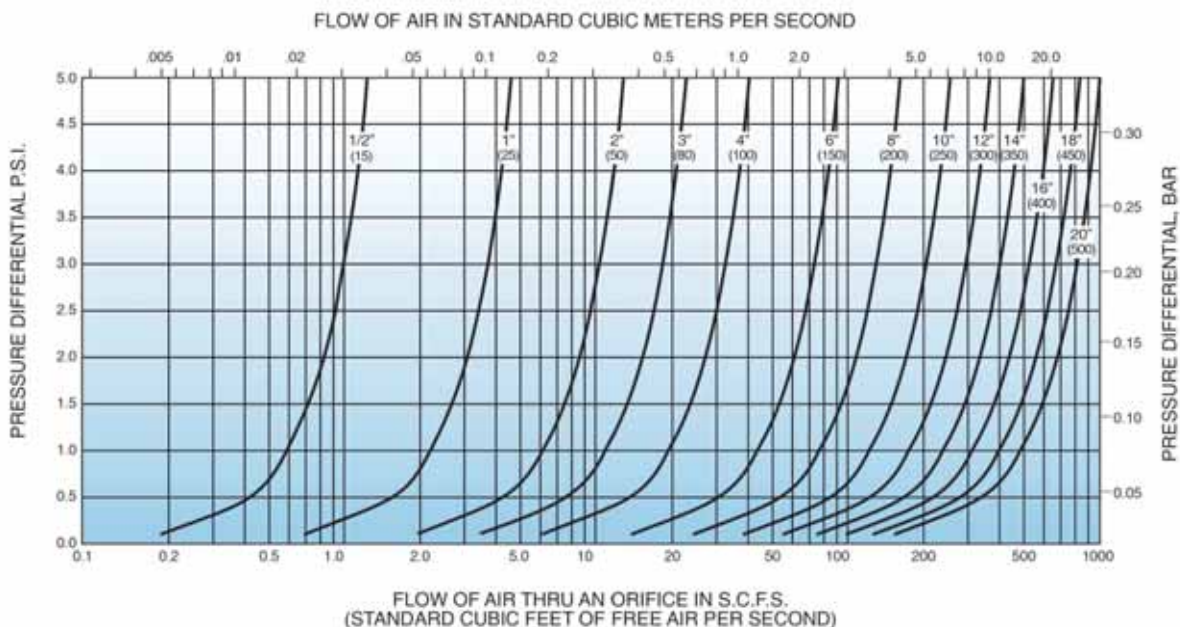

WATER AIR/VACUUM VALVES					
Inlet Size	Outlet Size	Model Number*	CWP PSI	Dimensions (Inches)	
				A	B
1/2" NPT	1/2" NPT	100S	300	6.13	7.00
1" NPT	1" NPT	101S	300	7.00	9.68
2" NPT	2" NPT	102S	300	9.50	12.00
3" NPT	3" NPT	103S	300	9.50	12.00
4" Flg	4" NPT	104S 154S	125lb - 150 250lb - 300	11.50	16.38
6" Flg	6" NPT	106S 156S	125lb - 150 250lb - 300	14.00	18.63
8" Flg	8" NPT	108S 158S	125lb - 150 250lb - 300	17.25	21.63
10" Flg	10" Flg	110F 160F	125lb - 150 250lb - 300	20.25	24.50
12" Flg	12" Flg	112F 162F	125lb - 150 250lb - 300	24.00	30.00
14" Flg	14" Flg	114F 164F	125lb - 150 250lb - 300	27.00	29.50
16" Flg	16" Flg	116F 166F	125lb - 150 250lb - 300	30.50	35.19
20" Flg	20" Flg	120F 170F	125lb - 150 250lb - 300	38.25	42.06

*NSF 61 & 372 Certified

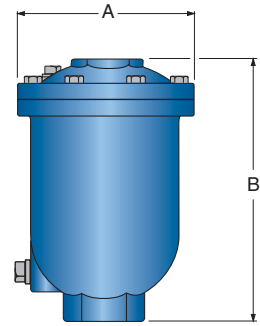

100S - 103S
Air/Vacuum Valves

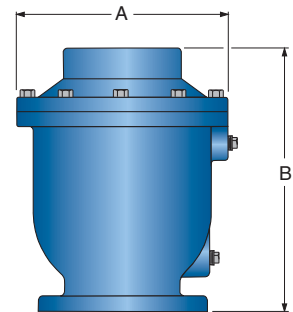

104S - 170F
Air/Vacuum Valves

WASTEWATER AIR/VACUUM VALVES					
Inlet Size	Outlet Size	Model Number	CWP PSI	Dimensions (Inches)	
				A	B
2" NPT	1" NPT	301A	150	7.00	15.06
2" NPT	2" NPT	302A	150	9.50	17.44
3" NPT	3" NPT	303A	150	9.50	17.44
4" Flg	4" NPT	304	150	11.50	36.63
6" Flg	6" NPT	306	150	14.00	36.38
8" Flg	8" NPT	308	150	17.25	40.13

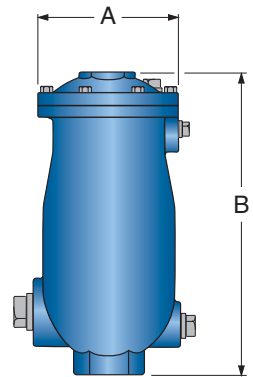

301A - 308
Wastewater Air/Vacuum Valves

Combination Air Valves



Clean Water



Wastewater

Operational Highlights:

- Provides the functions of both Air Release and Air/Vacuum Valves
- Exhausts large quantities of air at system start-up
- Releases air pockets during system operation
- Provides pipeline vacuum protection
- Fully complies with AWWA C512

Product Features:

- Single body incorporates both features within one valve
 - More compact and economical
- Dual body consists of two independent valves
 - Allows individual maintenance while still protecting the pipeline
 - Wider range of sizing options
- Inlets and outlets are equal to full nominal size
- Unconditionally guaranteed stainless steel floats
- Stainless steel 316 internal trim
- Non-clog design minimizes need for backwashing
- Exclusive high/low pressure resilient seating

Optional Accessories:

- Outlet hood with screen (prevents debris from entering valves)
- Ball, plug and butterfly isolation valves (allows valve maintenance)
- Inflow Preventer on outlet (stops flood water and resulting contamination from entering pipeline)
- Backwash kit (for severe wastewater applications)

MATERIALS OF CONSTRUCTION		
COMPONENT	STANDARD	OPTIONAL
Body, Cover and Baffle	Cast Iron ASTM A126 Class B Class 125 and 250	Ductile Iron ASTM A536 Grade 65-45-12 Stainless Steel ASTM A351 Grade CF8M
Trim	Type 316 Stainless Steel	-----
Seal	Buna-N	EPDM or Viton
Coating	Universal Acrylic Primer (external)	Non-Stick Fusion Bonded Epoxy (internal & external)

VENTING CAPACITY OF COMBINATION AIR VALVE ORIFICES

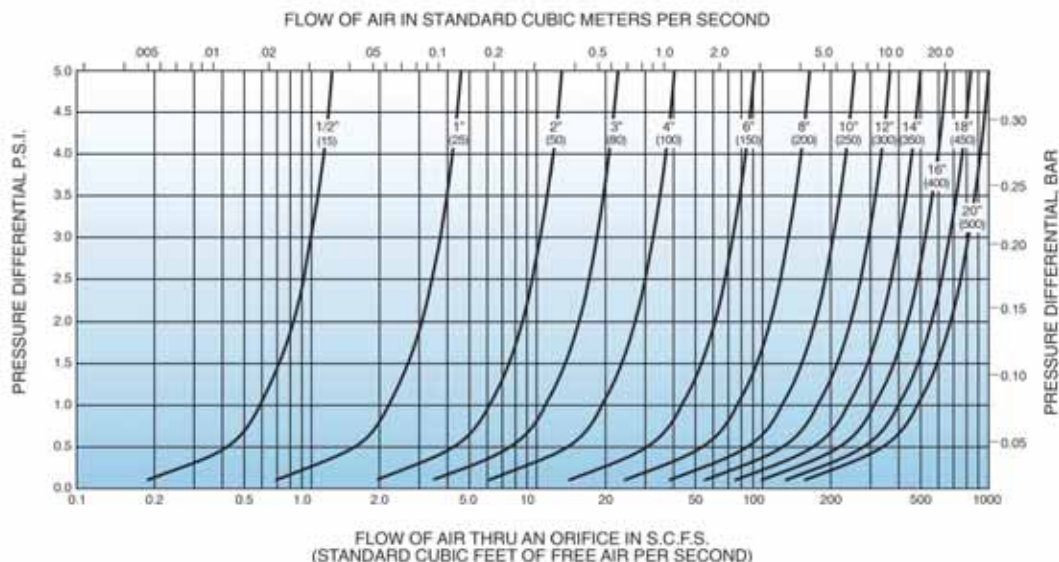

WATER COMBINATION AIR VALVES (SINGLE BODY)						
Inlet Size	Outlet Size	Model Number*	CWP PSI	Orifice Size	Dimensions (Inches)	
					A	B
1" NPT	1" NPT	201C.2	300	5/64"	11.38	10.50
2" NPT	2" NPT	202C.2	300	3/32"	14.00	13.00
3" NPT	3" NPT	203C.2	300	3/32"	16.00	15.00
3" 125lb Flg	3" NPT	203C.14	150	3/32"	16.00	16.75
3" 250lb Flg	3" NPT	203C.15	300	3/32"	16.00	17.25
4" 125lb Flg	4" NPT	204C.14	150	3/32"	18.50	19.00
4" 250lb Flg	4" NPT	204C.15	300	3/32"	18.50	20.25
6" 125lb Flg	6" NPT	206C	150	3/8"	21.00	18.75
6" 250lb Flg	6" NPT	256C	300	7/32"	21.00	18.75
8" 125lb Flg	8" NPT	208C	150	3/8"	25.00	21.50
8" 250lb Flg	8" NPT	258C	300	7/32"	25.00	21.50

*NSF 61 & 372 Certified

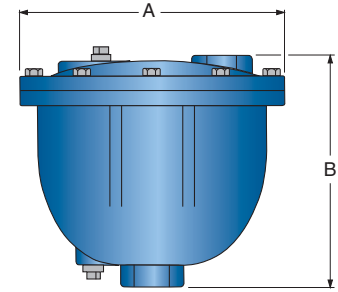

201C.2 - 204C.15
Single Body Combination Air Valves

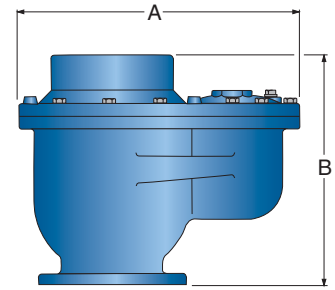

206C - 258C
Single Body Combination Air Valves

WASTEWATER COMBINATION AIR VALVES (SINGLE BODY)						
Inlet Size	Outlet Size	Model Number	CWP PSI	Orifice Size	Dimensions (Inches)	
					A	B
2" NPT	1" NPT	801A	150	1/8"	7.00	14.94
2" NPT	2" NPT	802A	150	9/64"	9.50	18.06
3" NPT	3" NPT	803A	150	11/64"	11.00	19.20
4" NPT	4" NPT	804	150	11/64"	11.00	23.50

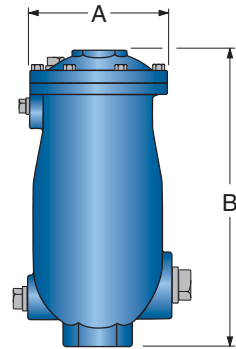

801A - 804
Wastewater Single Body Combination Air Valves



Single Body
Combination Air Valve



Single Body
Combination Air Valve with
FloodSafe® Inflow Preventer

Combination Air Valves

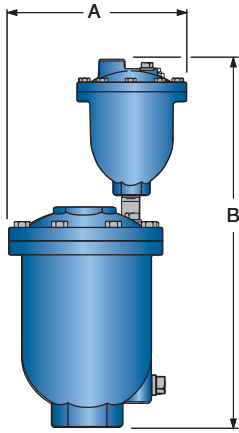

WATER COMBINATION AIR VALVES (DUAL BODY)						
Inlet Size	Outlet Size	Model Number*	CWP PSI	Orifice Size	Dimensions (Inches)	
					A	B
1" NPT	1" NPT	101S/22.7	300	1/16"	7.81	15.75
2" NPT	2" NPT	102S/22.7	300	1/16"	10.25	18.00
3" NPT	3" NPT	103S/22.7	300	1/16"	10.25	18.00

*NSF 61 & 372 Certified

101S/22.7 - 103S/22.7
Dual Body Combination
Air Valves

WATER COMBINATION AIR VALVES (DUAL BODY)						
Inlet Size	Outlet Size Air/Vacuum	Model Number*	CWP PSI	Orifice Size Air Release	Dimensions (Inches)	
					A	B
4" Flg	4" NPT	104S/38 154S/38.5	125lb - 150 250lb - 300	3/16" 5/32"	19.50	21.50
6" Flg	6" NPT	106S/38 156S/38.5	125lb - 150 250lb - 300	3/16" 5/32"	22.00	23.25
8" Flg	8" NPT	108S/38 158S/38.5	125lb - 150 250lb - 300	3/16" 5/32"	25.25	25.25
8" Flg	8" NPT	108S/45 158S/45.5	125lb - 150 250lb - 300	23/64" 7/32"	29.19	28.69
10" Flg	10" Flg	110F/38 160F/38.5	125lb - 150 250lb - 300	3/16" 5/32"	28.19	27.19
10" Flg	10" Flg	110F/45 160F/45.5	125lb - 150 250lb - 300	23/64" 7/32"	32.19	30.44
12" Flg	12" Flg	112F/38 162F/38.5	125lb - 150 250lb - 300	3/16" 5/32"	31.91	30.44
12" Flg	12" Flg	112F/45 162F/45.5	125lb - 150 250lb - 300	23/64" 7/32"	35.94	33.69
14" Flg	14" Flg	114F/38 164F/38.5	125lb - 150 250lb - 300	3/16" 5/32"	34.91	30.37
14" Flg	14" Flg	114F/45 164F/45.5	125lb - 150 250lb - 300	23/64" 7/32"	38.94	33.63
16" Flg	16" Flg	116F/38 166F/38.5	125lb - 150 250lb - 300	3/16" 5/32"	38.41	32.69
16" Flg	16" Flg	116F/45 166F/45.5	125lb - 150 250lb - 300	23/64" 7/32"	42.44	35.94

*NSF 61 & 372 Certified

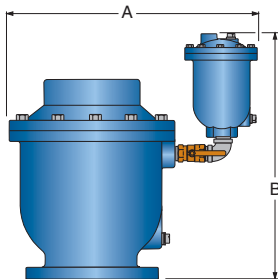

104S/38 - 166F/45.5
Dual Body Combination
Air Valves

WASTEWATER COMBINATION AIR VALVES (DUAL BODY)						
Inlet Size	Outlet Size	Model Number	CWP PSI	Orifice Size	Dimensions (Inches)	
					A	B
2" NPT	1" NPT	48A/301A	150	3/16"	25.80	20.20
2" NPT	1" NPT	49A/301A	150	7/16"	27.00	22.50
2" NPT	2" NPT	48A/302A	150	3/16"	27.00	20.20
2" NPT	2" NPT	49A/302A	150	7/16"	28.30	22.50
3" NPT	3" NPT	48A/303A	150	3/16"	34.00	21.00
3" NPT	3" NPT	49A/303A	150	7/16"	35.20	22.50

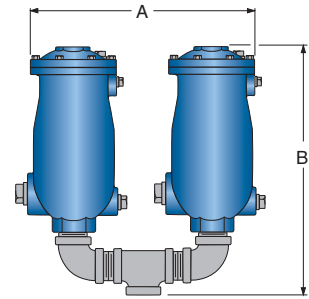

**48A/301A - 49A/303A
Dual Body Wastewater
Combination Air Valves**

WASTEWATER COMBINATION AIR VALVES (DUAL BODY)						
Inlet Size	Outlet Size	Model Number	CWP PSI	Orifice Size	Dimensions (Inches)	
					A	B
4" Flg	4" NPT	48A/304	150	3/16"	24.90	36.63
4" Flg	4" NPT	49A/304	150	7/16"	24.30	36.60
6" Flg	6" NPT	48A/306	150	3/16"	25.60	36.38
6" Flg	6" NPT	49A/306	150	7/16"	26.80	36.40
8" Flg	8" NPT	48A/308	150	3/16"	28.60	40.13
8" Flg	8" NPT	49A/308	150	7/16"	29.90	40.10

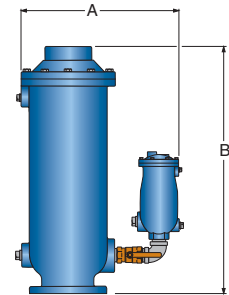

**48A/304 - 49A/308
Dual Body Wastewater
Combination Air Valves**



**Single Body Wastewater
Combination Air Valve**



**Dual Body Combination
Air Valve**

Surge-Suppression Air Valves

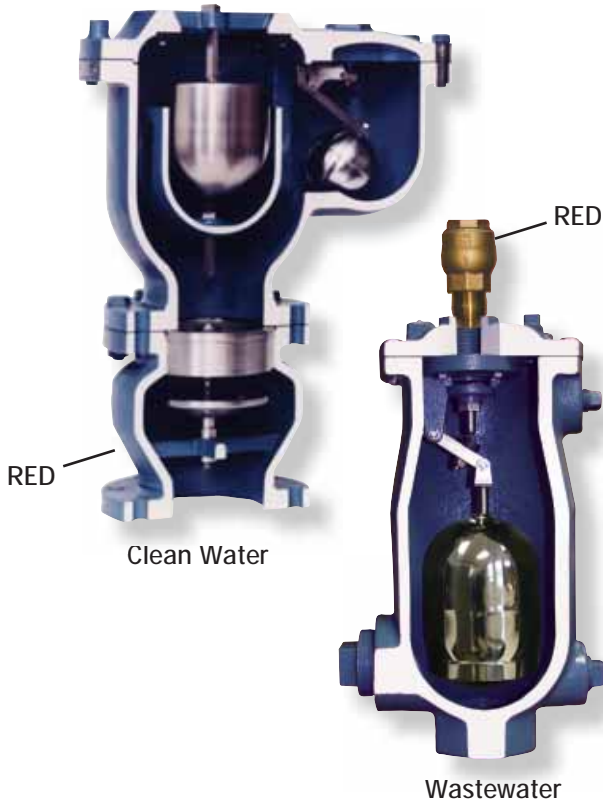

Operational Highlights:

- Provides full vacuum protection for the pipeline
- Provides slow closure suppressing surge in the pipeline
- Minimizes water blow-by during Air Valve closure
- Allows the use of smaller valve size by utilizing a maximum sizing differential pressure of 5 psig
- Releases entrained air while pipeline is operating to maintain pumping efficiency
- Includes Regulated Exhaust Device (RED)
- Fully complies with AWWA C512 and NSF 61

Surge-Suppression Air Valve Features:

- Restrictor disc provides regulated exhaust to limit secondary surges during column separation
- Ability to adjust air exhaust for greater surge suppression
- Provides full vacuum flow port

Optional Accessories:

- Outlet hood with screen (prevents debris from entering valves)
- Ball and butterfly isolation valves (allows valve maintenance)
- Inflow Preventer on outlet (stops flood water and resulting contamination from entering pipeline)
- Backwash kit (for severe wastewater applications)

MATERIALS OF CONSTRUCTION		
COMPONENT	STANDARD	OPTIONAL
Body	Cast Iron ASTM A126 Class B	Ductile Iron ASTM A536 Grade 65-45-12
Trim	Type 316 Stainless Steel (Air Valve) Lead Free Bronze ASTM B584 C87600 (RED)	Stainless Steel ASTM A351 Grade CF8M (RED)
Coating	Universal Acrylic Primer (external)	Non-Stick Fusion Bonded Epoxy (internal & external)

VENTING CAPACITY OF SURGE-SUPPRESSION AIR VALVE ORIFICES

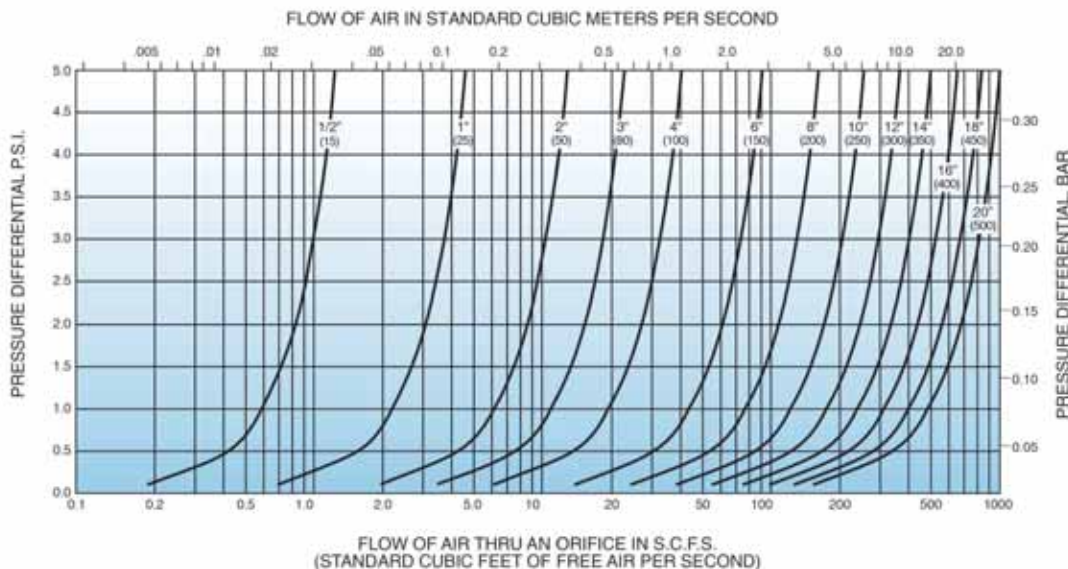

Surge-Suppression Air Valves

WATER SURGE-SUPPRESSION AIR VALVES (SINGLE BODY)						
Inlet Size	Outlet Size	Model Number*	CWP PSI	Orifice Size	Dimensions (Inches)	
					A	B
1" NPT	1" NPT	201CSS.1	250	5/64"	11.40	13.60
2" NPT	2" NPT	202CSS.1	250	3/32"	14.00	17.30
3" 125lb Flg	3" NPT	203CSSA.1	150	3/32"	16.00	22.75
3" 250lb Flg	3" NPT	253CSSA.1	300	3/32"	16.00	22.75
4" 125lb Flg	4" NPT	204CSSA.1	150	3/32"	18.50	27.00
4" 250lb Flg	4" NPT	254CSSA.1	300	3/32"	18.50	27.00
6" 125lb Flg	6" NPT	206CSSA.1	150	3/8"	21.00	30.00
6" 250lb Flg	6" NPT	256CSSA.1	300	7/32"	21.00	30.00
8" 125lb Flg	8" NPT	208CSSA.1	150	3/8"	25.00	36.00
8" 250lb Flg	8" NPT	258CSSA.1	300	7/32"	25.00	36.00

*NSF 61 & 372 Certified

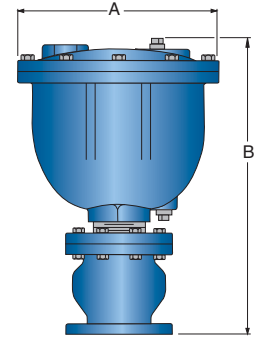

201CSS.1 - 258CSSA.1
Surge-Suppression Single Body
Air Valves

WATER SURGE-SUPPRESSION AIR VALVES (DUAL BODY)						
Inlet Size	Outlet** Size	Model Number*	CWP PSI	Orifice Size	Dimensions (Inches)	
					A	B
4" 125lb Flg	4" NPT	104SSA/38	150	3/16"	21.00	29.00
4" 250lb Flg	4" NPT	154SSA/38.5	300	5/32"	21.00	29.00
6" 125lb Flg	6" NPT	106SSA/38	150	3/16"	24.00	33.00
6" 250lb Flg	6" NPT	156SSA/38.5	300	5/32"	24.00	33.00
8" 125lb Flg	8" NPT	108SSA/38	150	3/16"	27.00	39.00
8" 250lb Flg	8" NPT	158SSA/38.5	300	5/32"	27.00	39.00
10" 125lb Flg	10" Flg	110FSSA/45	150	23/64"	32.10	46.20
10" 250lb Flg	10" Flg	160FSSA/45.5	300	7/32"	32.10	46.20
12" 125lb Flg	12" Flg	112FSSA/45	150	23/64"	36.10	48.20
12" 250lb Flg	12" Flg	162FSSA/45.5	300	7/32"	36.10	48.20

*NSF 61 & 372 Certified

**All outlet flanges are class 125 lb.

Note: For sizes 14" - 20" Consult Factory

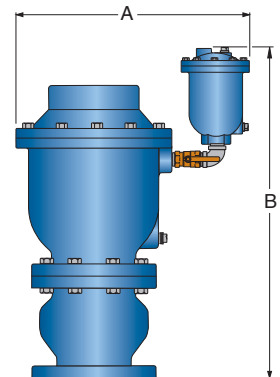

104SSA/38 - 162FSSA/45.5
Surge-Suppression Dual Body
Air Valves

WASTEWATER SURGE-SUPPRESSION AIR VALVES (SINGLE BODY)						
Inlet Size	Outlet Size	Model Number	CWP PSI	Orifice Size	Dimensions (Inches)	
					A	B
2" NPT	1" NPT	801SS	150	1/8"	7.00	18.00
2" NPT	2" NPT	802SS	150	9/64"	9.50	22.40
3" NPT	3" NPT	803SSA	150	11/64"	11.00	27.20
4" NPT	4" NPT	804SSA	150	11/64"	11.00	33.20

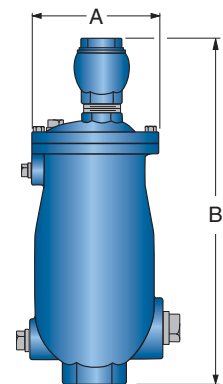

801SS - 804SSA
Surge-Suppression Single Body
Wastewater Air Valves

Air/Vacuum Valves for Vertical Pumps

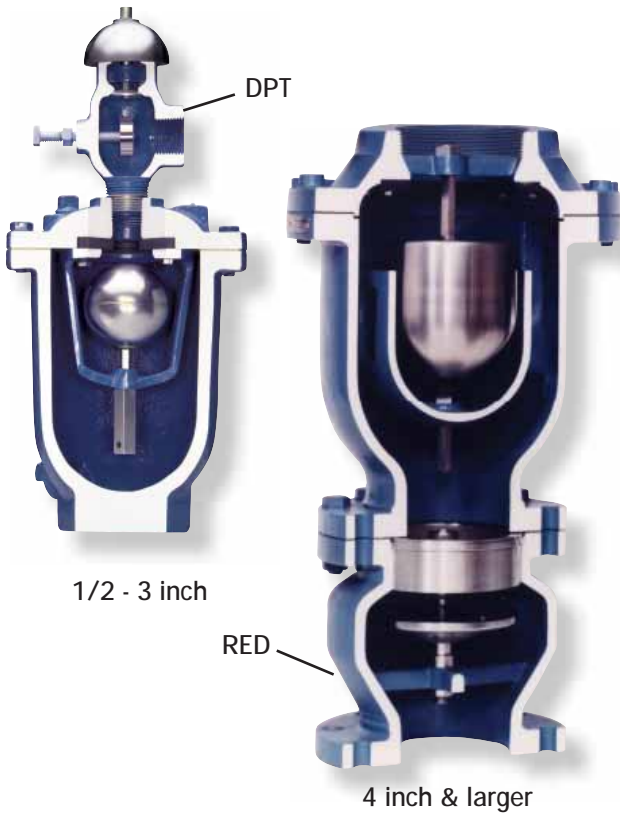

Operational Highlights:

- Regulates the exhaust of air on pump start-up
- Admits air to protect pump and mechanical seals
- Protects against air-related surges on pump start-up
- Fully complies with AWWA C512

Product Features:

- Unconditionally guaranteed 316 stainless steel floats
- Inlets and outlets are equal to full nominal pipe area
- 1/2" - 3" equipped with Dual Port Throttling Device
- 4" and larger equipped with Regulated-Exhaust Device mounted on the inlet

Dual Port Throttling Device (DPT):

- Adjustable discharge outlet provides regulated air exhaust
- Allows air to enter the system on pump shut down through an unrestricted independent vacuum port

Regulated-Exhaust Device (RED):

- Restrictor disc provides regulated exhaust to limit pump column surges
- Ability to adjust air exhaust for greater surge suppression
- Provides full vacuum flow port

MATERIALS OF CONSTRUCTION		
COMPONENT	STANDARD	OPTIONAL
Body and Cover	Cast Iron ASTM A126 Class B Class 125 and 250	Ductile Iron ASTM A536 Grade 65-45-12 Stainless Steel ASTM A351 Grade CF8M
Trim	Type 316 Stainless Steel (Air Valve) Lead Free Bronze ASTM B584 C87600 (RED)	-----
Coating	Universal Acrylic Primer (external)	Non-Stick Fusion Bonded Epoxy (internal & external)

AIR/VACUUM VALVE FOR VERTICAL PUMP SERVICE SIZING			
Valve Size	No Head Pump Capacity, GPM	Model Number	
		150 PSI Model	300 PSI Model
1/2"	0 - 350	100ST	
1"	351 - 1,350	101ST	
2"	1,351 - 4,000	102ST	
3"	4,001 - 7,000	103ST	
4"	7,001 - 11,000	104SSA.1	154SSA.1
6"	11,001 - 24,000	106SSA.1	156SSA.1
8"	24,001 - 50,000	108SSA.1	158SSA.1
10"	50,001 - 70,000	110FSSA.1	160FSSA.1
12"	70,001 - 110,000	112FSSA.1	162FSSA.1

AIR/VACUUM VALVE FOR VERTICAL PUMPS WITH DUAL PORT THROTTLING DEVICE					
Inlet Size	Outlet Size	Model Number	CWP PSI	Dimensions (Inches)	
				A	B
1/2" NPT	1/2" NPT	100ST	300	6.13	11.75
1" NPT	1" NPT	101ST*	300	7.00	14.75
2" NPT	2" NPT	102ST*	300	9.50	20.13
3" NPT	3" NPT	103ST*	300	9.50	22.13

*UL Listed for fire pump service

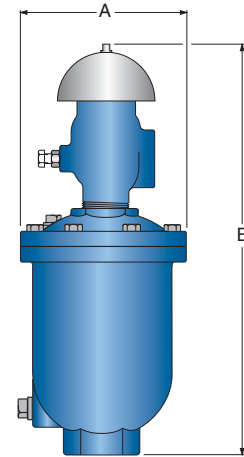

100ST - 103ST
Air Valves with
Dual Port Throttling Device

AIR/VACUUM VALVE FOR VERTICAL PUMPS WITH REGULATED-EXHAUST DEVICE					
Inlet Size	Outlet Size	Model Number	CWP PSI	Dimensions (Inches)	
				A	B
4" 125lb Flg	4" NPT	104SSA.1	150	11.50	23.63
4" 250lb Flg	4" NPT	154SSA.1	300	11.50	23.63
6" 125lb Flg	6" NPT	106SSA.1	150	14.00	28.50
6" 250lb Flg	6" NPT	156SSA.1	300	14.00	28.50
8" 125lb Flg	8" NPT	108SSA.1	150	17.25	34.63
8" 250lb Flg	8" NPT	158SSA.1	300	17.25	34.63
10" 125lb Flg	10" 125lb Flg	110FSSA.1	150	20.30	40.10
10" 250lb Flg	10" 125lb Flg	160FSSA.1	300	20.30	40.10
12" 125lb Flg	12" 125lb Flg	112FSSA.1	150	24.00	45.10
12" 250lb Flg	12" 125lb Flg	162FSSA.1	300	24.00	45.10

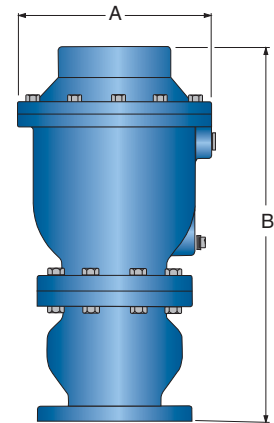

104SSA.1 - 162FSSA.1
Air Valves with
Regulated-Exhaust Device



Air/Vacuum Valve with Dual Port Throttling Device



Air/Vacuum Valve with Dual Port Throttling Device for Vertical Turbine Pumps

Vacuum Breaker Valves



Vacuum Breaker with Optional Hood and Air Release Valve

Operational Highlights:

- Provides vacuum protection for pipelines and tanks
- Cushions surges related to column separation
- Opens in response to a 0.25 psi vacuum

Product Features:

- Resilient seals provide drop tight seating
- Full flow areas provide maximum vacuum protection

Optional Accessories:

- Hood with screen (prevents debris from entering valves)
- Air Release Valve (slowly releases air to prevent violent rejoining of water columns)
- Inflow Preventer on outlet (stops flood water and resulting contamination from entering pipeline)

MATERIALS OF CONSTRUCTION		
COMPONENT	STANDARD	OPTIONAL
Body and Cover	Cast Iron ASTM A126 Class B Class 125 and 250	Ductile Iron ASTM A536 Grade 65-45-12
Trim	Lead Free Bronze, ASTM B584, C87600	Stainless Steel ASTM A351 Grade CF8M
Coating	Universal Acrylic Primer (external)	Non-Stick Fusion Bonded Epoxy (internal & external)

VENTING CAPACITY OF VACUUM BREAKER ORIFICES

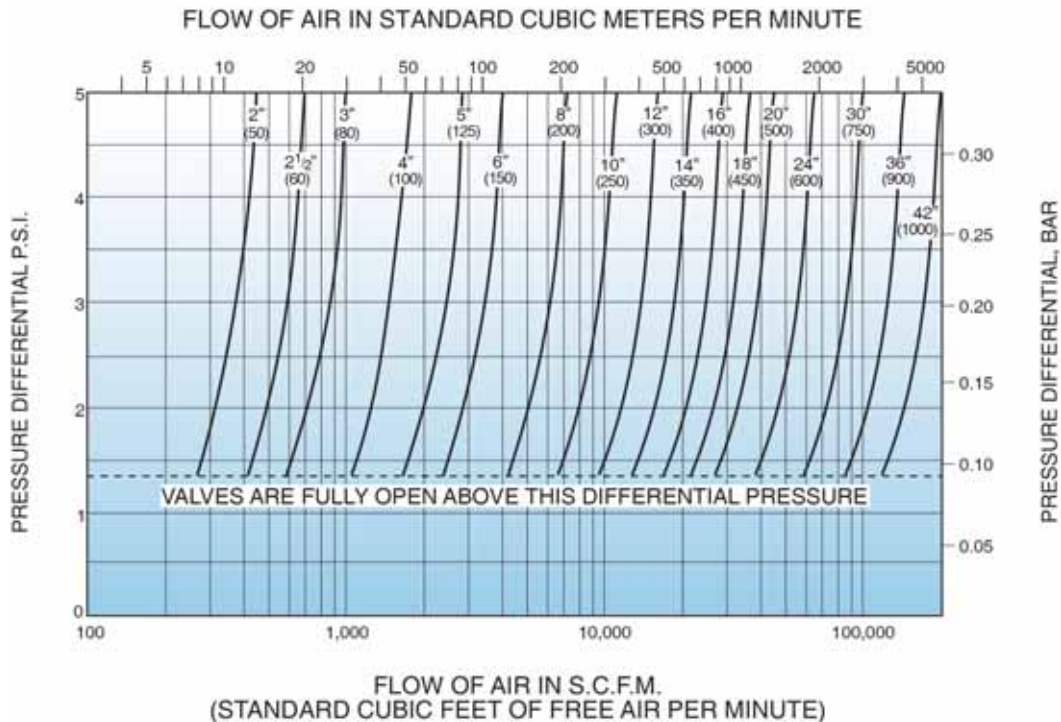

Vacuum Breaker Valves

THREADED VACUUM BREAKER AIR VALVE					
Inlet	Outlet	Model Number*	CWP	Dimensions (Inches)	
				A	B
1/2" NPT	1/2" NPT	100VB	300	6.13	7.00
1" NPT	1" NPT	101VB	300	7.00	9.50
2" NPT	2" NPT	102VB	300	9.50	12.00
3" NPT	3" NPT	103VB	300	9.50	12.50

*NSF 61 & 372 Certified

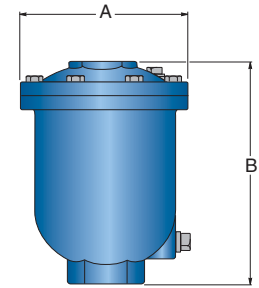

100VB-103VB
Vacuum Breaker Valves

FLANGED VACUUM BREAKER AIR VALVE						
Inlet Size*	Model Number*		Model Number*		Dimensions (Inches)	
	125lb Class (CWP)		250lb Class (CWP)		A	B
2	1802AVB.1	200	1852AVB.1	400	7.00/7.50	5.50
2.5	1825AVB.1	200	1875AVB.1	400	7.00/7.50	5.50
3	1803AVB.1	200	1853AVB.1	400	7.50/8.25	6.00
4	1804AVB.1	200	1854AVB.1	400	9.00/10.00	7.25
5	1805AVB.1	200	1855AVB.1	400	10.00/11.00	8.50
6	1806AVB.1	200	1856AVB.1	400	11.00/12.50	9.75
8	1808AVB.1	200	1858AVB.1	400	13.50/15.00	12.50
10	1810AVB.1	200	1860AVB.1	400	16.00/17.50	15.50
12	1812AVB.1	200	1862AVB.1	400	19.00/20.50	14.30

*NSF 61 & 372 Certified

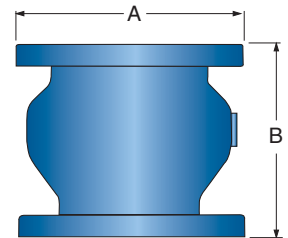

1802AVB.1-1862AVB.1
Vacuum Breaker Valves

FLANGED VACUUM BREAKER WITH AIR RELEASE VALVE						
Inlet Size*	Model Number*		Model Number*		Dimensions (Inches)	
	125lb Class (CWP)		250lb Class (CWP)		A	B
3	1803AVB/38	150	1853VB/38.5	300	11.00	6.00
4	1804AVB/38	150	1854VB/38.5	300	11.50	7.25
5	1805AVB/38	150	1855VB/38.5	300	12.60	8.50
6	1806AVB/38	150	1856VB/38.5	300	13.30	9.75
8	1808AVB/38	150	1858VB/38.5	300	14.70	12.50
10	1810AVB/38	150	1860VB/38.5	300	16.30	15.50
12	1812AVB/38	150	1862VB/38.5	300	18.00	14.30

*NSF 61 & 372 Certified

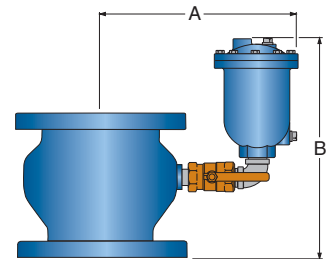

1803AVB/38 - 1862AVB/38.5
Vacuum Breaker Valves

FLANGED VACUUM BREAKER WITH AIR RELEASE VALVE FOR WASTEWATER SERVICE							
Inlet Size*	Model Number	Model Number with Air Release Valve		Dimensions (Inches)			
		125lb Class (CWP)		A	B	C	D
3	1803VBS	1803VBS/48A	200	27.10	26.10	7.50	9.80
4	1804VBS	1804VBS/48A	200	20.10	21.80	9.00	10.50
6	1806VBS	1806VBS/48A	200	22.90	23.60	11.00	13.80
8	1808VBS	1808VBS/48A	200	25.55	25.20	13.50	17.60
10	1810VBS	1810VBS/48A	200	28.30	27.00	16.00	20.90
12	1812VBS	1812VBS/48A	200	31.50	25.30	19.00	20.10

*For sizes 14" - 42" consult factory

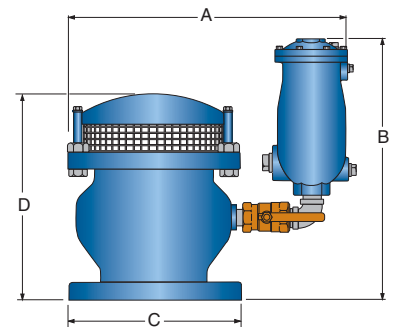

1803VBS - 1812VBS/48A
Vacuum Breaker Valves

Vacuum Priming Valves

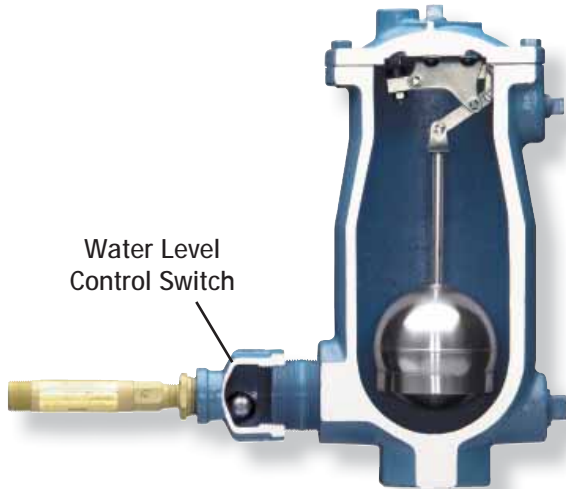

Operational Highlights:

- Allows the extraction of air from the pump housing and suction piping
- Float rises and closes the priming valve to prevent fluid from flowing into the vacuum priming system
- Continues to release air while the pump is running

Product Features:

- Specifically designed to prevent fluid leakage
- Flow sensitive float
- Stainless steel 316 internal trim and float

Optional Accessories:

- Water Level Control Switch (Mercury-Free)

MATERIALS OF CONSTRUCTION		
COMPONENT	STANDARD	OPTIONAL
Body and Cover	Cast Iron ASTM A126, Class B	Ductile Iron ASTM A536 Grade 65-45-12 Stainless Steel ASTM A351 Grade CF8M
Trim	Stainless Steel, Type 316	-----
Coating	Universal Acrylic Primer (external)	Non-Stick Fusion Bonded Epoxy (internal & external)

VACUUM PRIMING VALVES						
Inlet Size	Outlet Size	Model No.	CWP PSI	Orifice Size	Dimensions (Inches)	
					A	B
2" NPT	1/2" NPT	38P	150	3/16"	7.00	15.31
2" NPT	1/2" NPT	38P.2	75	5/16"	7.00	15.31
2" NPT	1" NPT	45P	150	23/64"	9.50	17.56
2" NPT	1" NPT	45P.3	75	1/2"	9.50	17.56

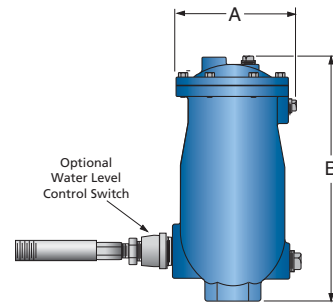

38P - 45P.3
Vacuum Priming Valve with Optional Water Level Control Switch

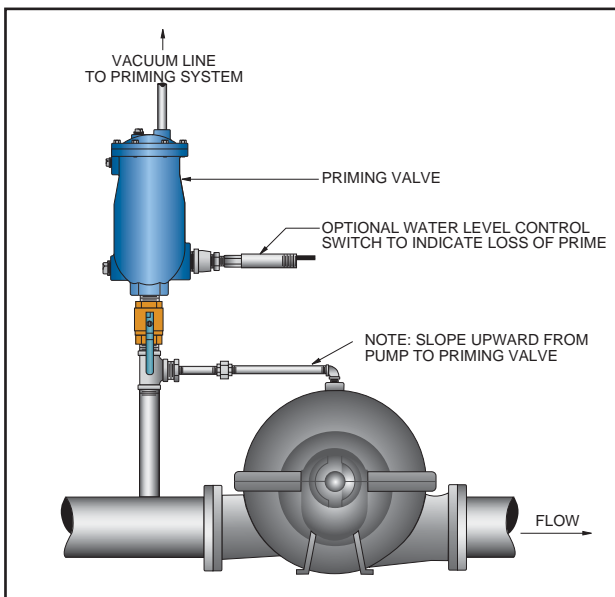

Recommended Piping Arrangement



Vacuum Priming Valve

The Val-Matic Air Valve Sizing program is an easy to use, indispensable web based program that allows engineers to more effectively and efficiently design their water and wastewater piping systems.

- 1 The pipeline profile data is entered into the program which evaluates system data and develops sizing criteria such as slope for each pipeline segment and flow rate due to slope.
- 2 It will recommend valve locations, sizes and models and print a valve schedule.
- 3 It will also prepare a pipeline profile for the user. Finally, the program will save your data for future reference.

1

Pipeline Air Valve Sizing

Name:

Owner:

Engineer:

Max Flow Rate:

Fill Rate:

Valve Selection Criteria:

Type of Media:

Pipe Material:

Pipe Inner Diameter:

Pipe Line Profiles

Feet

#	Station	Elevation	
1	<input type="text" value="0"/>	<input type="text" value="0"/>	<input type="text" value="v"/>
2	<input type="text" value="3200"/>	<input type="text" value="10"/>	<input type="text" value="v"/>
3	<input type="text" value="8400"/>	<input type="text" value="10"/>	<input type="text" value="v"/>
4	<input type="text" value="9200"/>	<input type="text" value="20"/>	<input type="text" value="v"/>
5	<input type="text" value="11200"/>	<input type="text" value="16"/>	<input type="text" value="v"/>

2

Station (ft)	Elevation (ft)	Description	Value Recommendations (Size/Model)	Flow Rate CFS	Slope
0	0	Beginning of Pipeline	No valve necessary	0.000	0.000
1600	5	Long Ascent	6 IN #106SS Air/Vac Reg-Ex	38.680	0.003
3200	10	High Point	8 IN #108SS/38 Surge-Suppression	77.360	0.003
4933	10	Horizontal Run	2 IN #38.2 Air Release	0.000	0.000
6666	10	Horizontal Run	4 IN #104SS/22.9 Surge-Suppression	0.000	0.000
8400	10	Low Point	No valve necessary	0.000	0.000
9200	20	High Point	10 IN #110FSS/45 Surge-Suppression	134.662	0.013

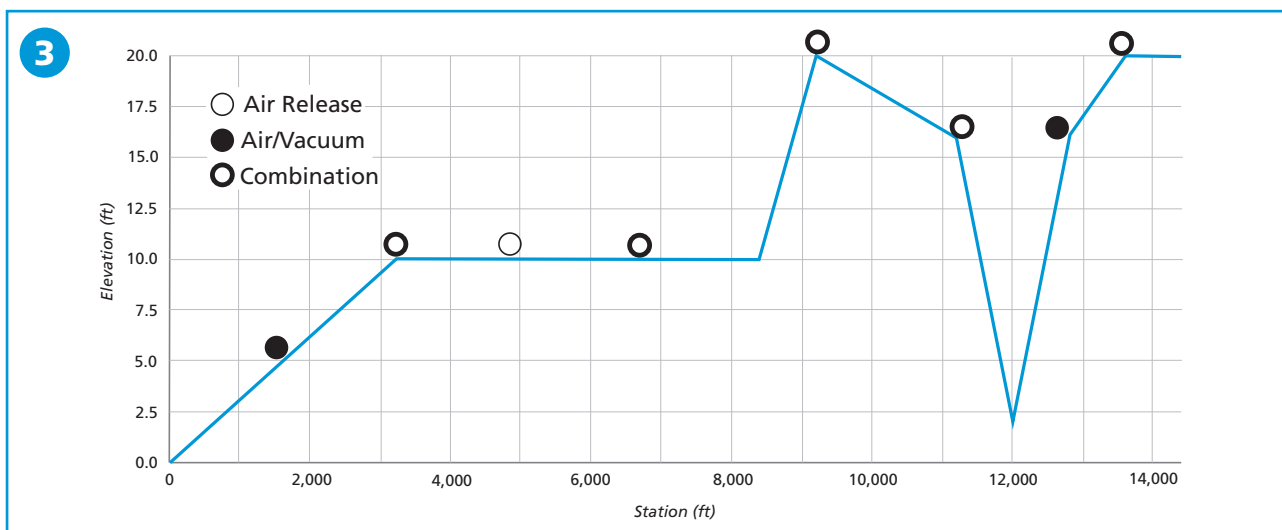

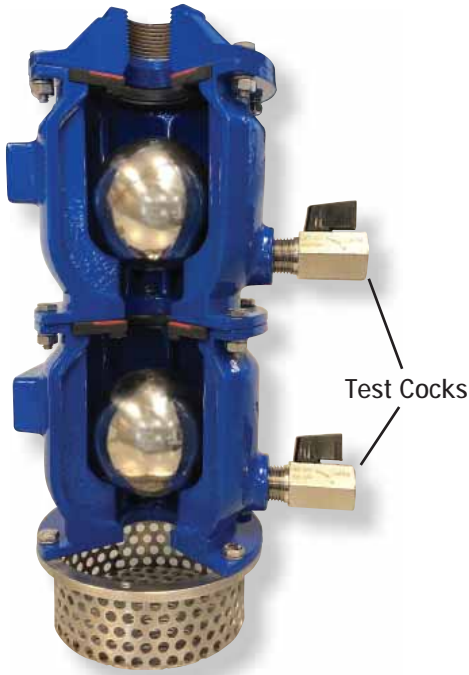

Operational Highlights:

- Piped to an outlet for an air valve
- Protects potable water systems from flooding and malicious contamination
- Field testing capability
- Low pressure shut off
- Dual float checks for added protection
- Fully complies with AWWA C514 and the Ten State Standards for Water Works

Product Features:

- Cross contamination control
- Adaptable to existing air valve installations
- Dual chamber design with upper chamber as a back up
- Dual float checks designed to assure rapid closure upon the entry of fluid into the chamber.
- Patented resilient seats are specially designed and formulated to assure drop tight closure at low pressures.
- Test ports allow for independent testing of both chambers
- Basket screen prevents debris from entering
- Port sized cover to allow for full venting capacity of air valve or vent

Optional Accessories:

- Field test kit
- Wall bracket

MATERIALS OF CONSTRUCTION	
COMPONENT	STANDARD
Upper & Lower Chambers, Cover	Ductile Iron, ASTM A536 Grade 65-45-12
Upper & Lower Check Floats	Stainless Steel, Type 316
Check Seat	Resilient
Basket Screen	Stainless Steel, Type 304
Coatings	Fusion Bonded Epoxy (internal/External)



FloodSafe® Inflow Preventer



FloodSafe® Inflow Preventer with a Combination Air Valve

FLOODSAFE® INFLOW PREVENTER					
Valve Size	Model Number**	Connection Size	PSI	Dimensions (Inches)	
				A	B
1"*	1301	1" NPT	25	6.38	13.13
2"*	1302	2" NPT	25	7.25	16.63
3"	1303	3" NPT	25	9.00	19.88
4"	1304	4" NPT	25	9.25	23.00
6"	1306	6" FLG	25	12.75	30.75
8"	1308	8" FLG	25	14.62	36.88
12"	1312	12" FLG	25	20.25	53.50
16"	1316	16" FLG	25	24.88	68.13

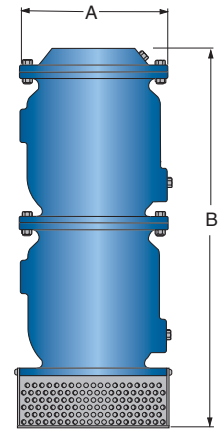

1301-1316
FloodSafe®

* ASSE 1063 Certified
**NSF 372 Certified

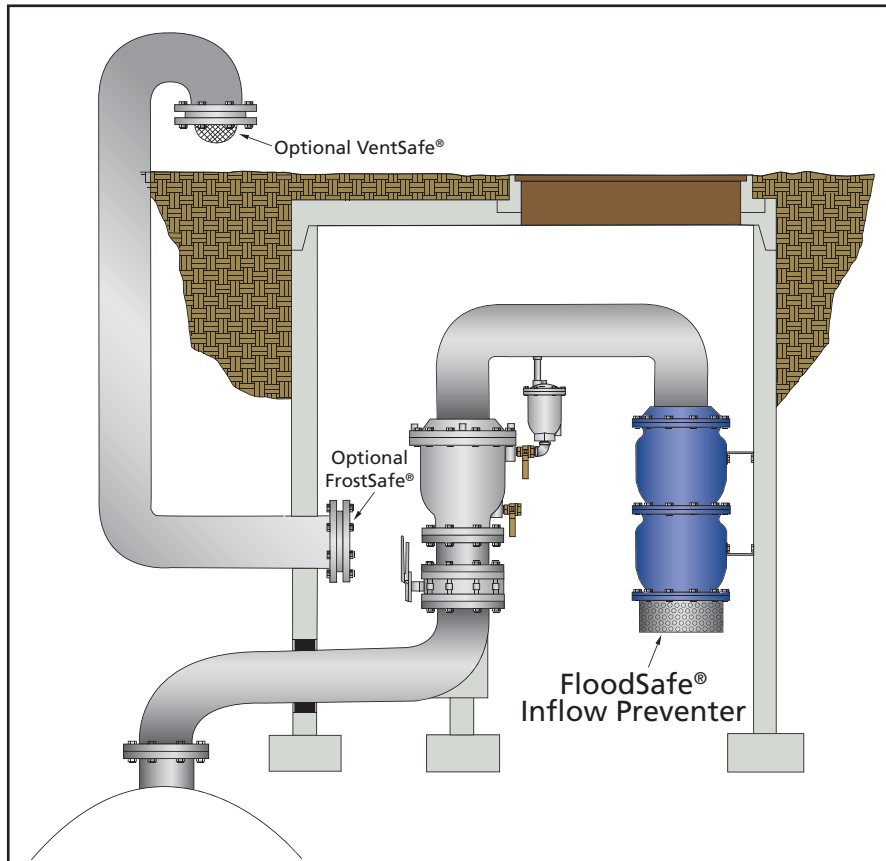

Typical Vault Installation with FloodSafe® Inflow Preventer

The FloodSafe® is piped to the outlet of an air release valve, air/vacuum valve, or combination air valve or vent. As water in a flooded area or vault rises, the float check in the lower chamber rises preventing contaminated water from continuing past the chamber. The redundant upper chamber provides a backup in much the same way a backflow preventer works. If contaminated water continues past the seat of the lower chamber the float check in the upper chamber rises preventing fluid from reaching the air valve outlet. Under normal operating conditions the FloodSafe® provides full venting capacity of the air valve or vent.



Operational Highlights:

- Wafer style bidirectional hingeless damper
- Installed in vent piping
- Protects air valve from freezing
- Minimizes the flow of cold air into vaults through vent pipes
- Provides 100% flow area
- 100% corrosion resistant construction
- Allows Air Valves to function at full rated capacity

Product Features:

- High density polyethylene body
- Damper seal
- Adaptable to existing vent pipes
- Wafer design minimizes space requirements

MATERIALS OF CONSTRUCTION	
COMPONENT	STANDARD
Body	High Density Polyethylene (HDPE)
Rubber Membrane	Nylon Reinforced High Grade Neoprene
Damper Seal	PETG
Body Bolt	Stainless Steel, Type 316

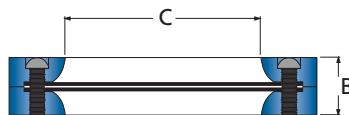
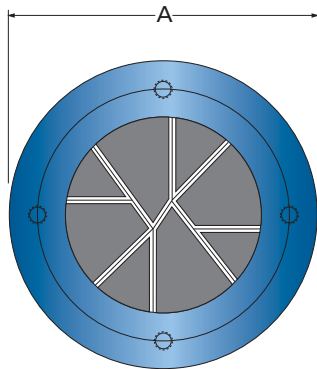

FROSTSAFE® TWO-WAY DAMPER				
Size	Model Number*	Dimensions (Inches)		
		A	B	C
4	1504	6.75	0.75	4.00
6	1506	8.88	1.00	6.00
8	1508	10.88	1.25	8.00
12	1512	16.00	2.00	12.00

*NSF 372 Certified



FrostSafe® Two-Way Damper



Operational Highlights:

- Installed in vault or reservoir vent pipes
- Helps prevent bugs, birds and small animals from nesting in vent pipes
- Helps prevent malicious introduction of liquids and other matter
- Provides 100% flow area
- 100% corrosion resistant construction

Product Features:

- Flow area equal to 100% of pipe area
- Adapts to existing vent pipes
- Wafer design minimizes space requirements
- 24 mesh screen complies with US EPA and Ten State Standard requirements for tank vent lines

MATERIALS OF CONSTRUCTION	
COMPONENT	STANDARD
Body	45 Shore D PVC
Screen, 24 Mesh	Stainless Steel, Type 304
Cage, 2 Mesh	Stainless Steel, Type 304

VENTSAFE® SECURITY CAGE					
Size	Model Number*	Dimensions (Inches)			
		A	B	C	D
4	1604	6.75	0.375	3.76	2.37
6	1606	8.63	0.375	5.75	3.37
8	1608	10.88	0.375	7.77	4.37
12	1612	16.00	0.375	11.75	6.00

*NSF 372 Certified

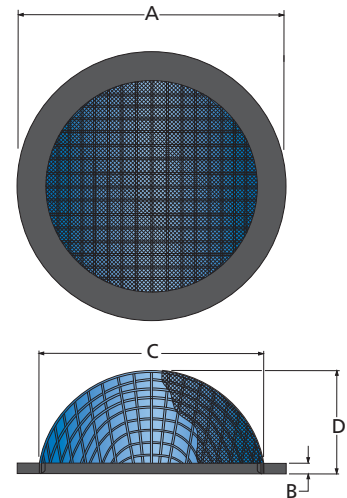

VentSafe® Security Cage



VentSafe® Security Cage
Installed on Vent Pipe



Val-Matic has developed the most comprehensive line of water and wastewater air valves available today.



VAL-MATIC®



Swing-Flex®
Check Valves



Designed and Manufactured
to AWWA C508
NSF/ANSI 61 & 372 Certified

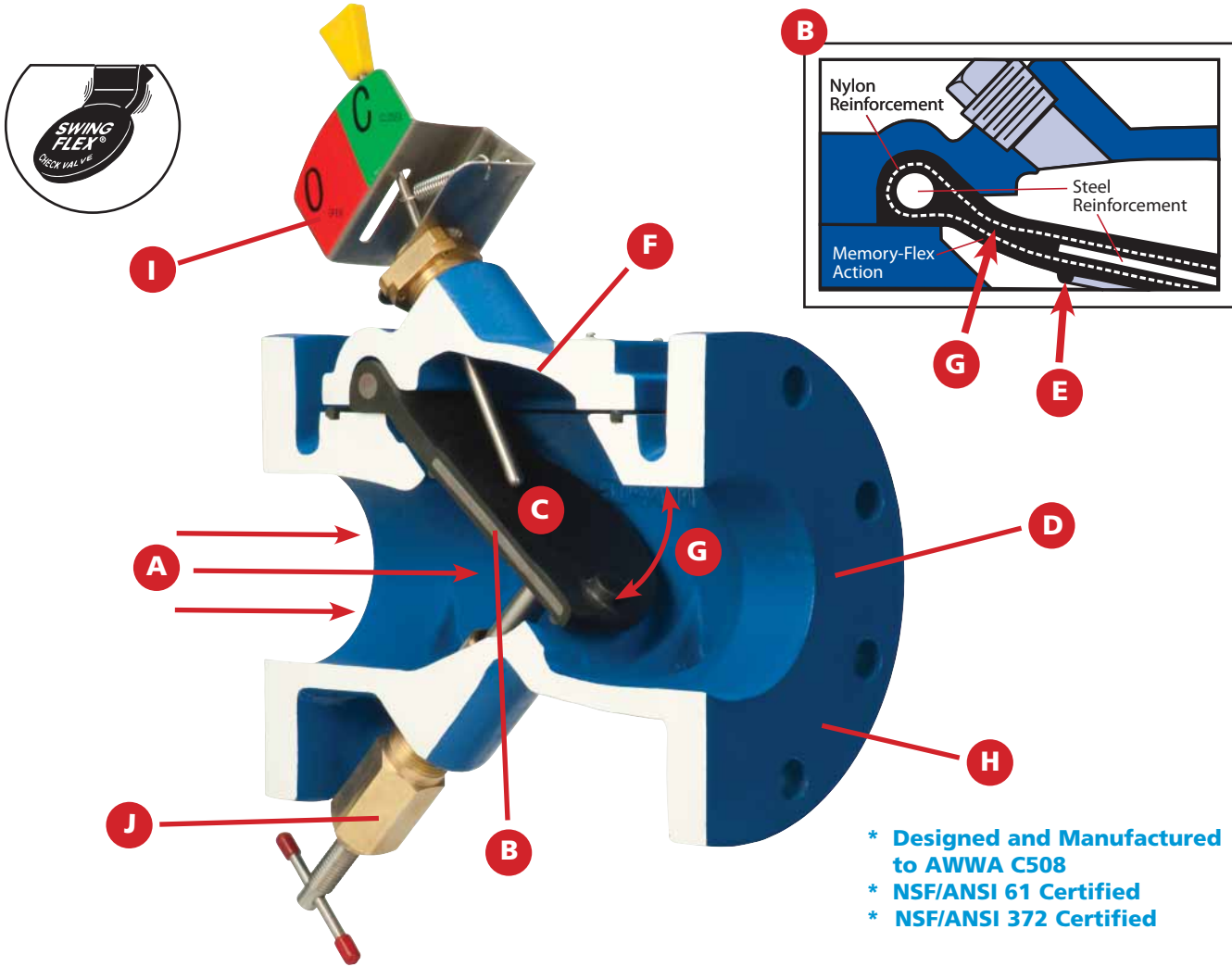

Swing-Flex®
Check Valves

- * Designed and Manufactured to AWWA C508
- * NSF/ANSI 61 Certified
- * NSF/ANSI 372 Certified

A. Non-Clog Design

100% flow area for improved flow characteristics and lower headloss. Unrestricted flow area combined with smooth streamlined contouring allows passage of large solids minimizing the potential for clogging.

B. Reinforced Disc

The one piece precision molded disc is steel and nylon reinforced to provide years of trouble free performance. It is backed by a 25 year warranty for the flex portion of the disc.

C. One Moving Part

The Memory-Flex™ disc, the only moving part, assures long life with minimal maintenance. No packing, mechanical hinges, pivot pins or bearings to wear out.

D. Body

Ductile Iron Body for 250 PSI rating.

E. Drop Tight Seating

The synthetic reinforced disc, with its integral O-ring type seal design assures positive seating at high and low pressures.

F. Domed Access Port

Full size top access port allows removal of disc without removing the valve from the line and provides flushing action over the valve disc for clog free performance. Access cover includes a drilled and tapped port for installation of optional Disc Position Indicator (I).

G. Non-Slam Closure

"Short Disc Stroke" combined with Memory-Flex™ Disc Action reduces potentially destructive water hammer.

H. Fusion Bonded Epoxy

Fusion Bonded Epoxy (FBE) is the standard coating on the interior and exterior of the valve. The FBE is NSF/ANSI 61 certified.

I. Mechanical Disc Position Indicator

Provides clear indication of the valve's disc position. Can also be provided with a SCADA compatible limit switch for off site monitoring. (Optional)

J. Backflow Actuator

Body is drilled and tapped for installation of backflow actuator. Available for use when manual backflow operation is required. Most commonly used for priming pumps, back flushing, draining lines and system testing. (Optional)

Proven Design

Efficiency and reliability through simplicity of design is the key to the superior performance and long life of the Val-Matic Swing-Flex® Check Valve. The streamlined contour of the Swing-Flex® body provides 100% flow area with no restrictions at any point through the valve (Figure 1). Flow tests performed by the Utah State Water Research Laboratory have shown that this unique body design produces minimal headloss through the valve. Flow and headloss charts, developed from the test data, are shown on Page 4.

In the full open position, the disc is stabilized by using smooth streamlined body contouring to direct the flow towards the disc preventing disc flutter and assuring long disc life (Figure 1). Clog resistant performance is achieved by maintaining an unobstructed 100% flow area and the use of a smooth fusion bonded epoxy coating. The entrapment or collection of solids and stringy materials is minimized by the elimination of hinge mechanisms in the valve design. The standard 4" Swing-Flex® is designed to pass a 3" solid.

Preferred Features

The Swing-Flex® Check Valve non-slam closing characteristic is achieved by utilizing a "Short Disc Stroke" in conjunction with the unique "Memory-Flex™ action" of the valve's disc. The 35° stroke, a result of the angled seat, is less than half the typical 80° to 90° stroke of a conventional swing check valve. (Figures 1 & 2)

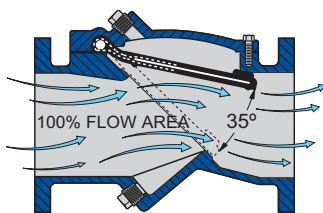

Figure 1. Swing-Flex Geometry

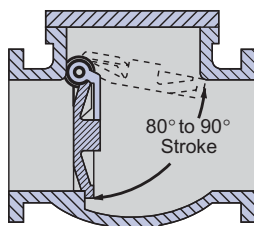

Figure 2. Conventional Geometry

The short disc stroke and "Memory-Flex™ action" (Figure 1) serve to reduce the closing time of the valve minimizing flow reversal and the resultant water

hammer normally associated with the sudden stoppage of reverse flow.

Operational reliability is achieved by utilizing just one moving part, the Memory-Flex™ disc. The steel and nylon reinforcements are precision molded into the disc, providing a tough, durable disc with a 25-year warranty on the flex portion of the disc (Figure 3). Unlike conventional swing check valves, the Swing-Flex® has no packing, mechanical hinges, shafts, pivot pins, or bearings to wear out. The Memory-Flex™ disc with its integral O-ring type seal design assures drop tight seating at both high and low working pressures. Upon conclusion of a 1,000,000 (one million) cycle test, an independent testing laboratory reported that the valve had no visible signs of wear and remained drop tight.

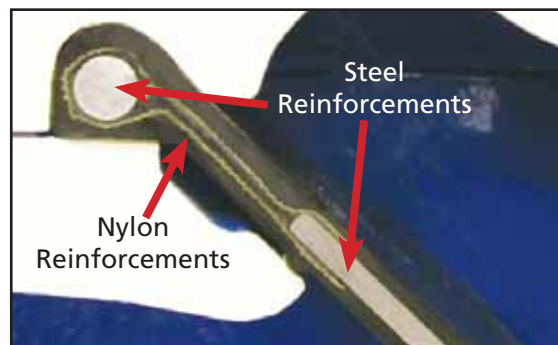

Figure 3. Reinforced Disc

Advanced Technology

Incorporating the latest in valve technology assures a high-quality valve that will provide long service. The design process utilized Solid Modeling and Finite Element Analysis (FEA) of the key structural components. Flow and headloss data was derived from flow tests, mathematical models and Computational Fluid Dynamics (CFD). Manufacturing technology uses automated process control in the foundry and ISO 9001 controlled manufacturing processes.

Product Certifications

Val-Matic Swing-Flex® check valves are certified for use in drinking water in accordance with NSF/ANSI 61 and are Certified Lead-Free per NSF/ANSI 372. Every valve is tested in accordance with AWWA C508. All valves are tested on automated hydraulic test rigs with gauges calibrated per ISO standards. All Val-Matic Valves are manufactured under a certified ISO 9001 quality management system.

PRESSURE RATINGS

MAXIMUM PRESSURE RATINGS*		
SIZE RANGE in (mm)	CONNECTION	CWP psig (Bar)
2" - 24" (50-600 mm)	ANSI Class 125 Ductile Iron	250 (17.2)
30" - 48" (800-1200 mm)	ANSI Class 125 Cast Iron	150 (10.3)
30" - 48" (800-1200 mm)	ANSI Class 125 Ductile Iron	250 (17.2)

*For Critical Low Pressure Applications, such as gravity flow and digester gas, low-durometer (soft rubber) discs are available. Consult Factory.

AWWA Note: If the purchaser specifies a wetted component that was not tested and certified to NSF/ANSI 61, the certification may not be valid.

MATERIALS OF CONSTRUCTION

COMPONENT	STANDARD	OPTIONAL
Body 2" - 24" (50-600 mm)	Ductile Iron ASTM A536, Grade 65-45-12	ASTM A351, CF8M 316 SS 3" - 12" (80-300 mm)
Body 30" - 48" (800-1200 mm)	Ductile Iron ASTM A536, Grade 65-45-12	Cast Iron ASTM A126, Class B
Disc	Buna-N w/Alloy Steel & Nylon Reinforcement	EPDM, Hypalon, Viton
Coatings	Fusion Bonded Epoxy (Int/Ext)	Rubber Lining, Glass Lining
Mechanical Indicator (Optional)	17-4 Stainless Steel, Lead-Free Bronze	-
Backflow Actuator (Optional)	T304 Stainless Steel, Lead-Free Bronze	-
Oil Cushion 6" and larger (Optional)	17-4 Stainless Steel, Lead-Free Bronze	-

Headloss Chart

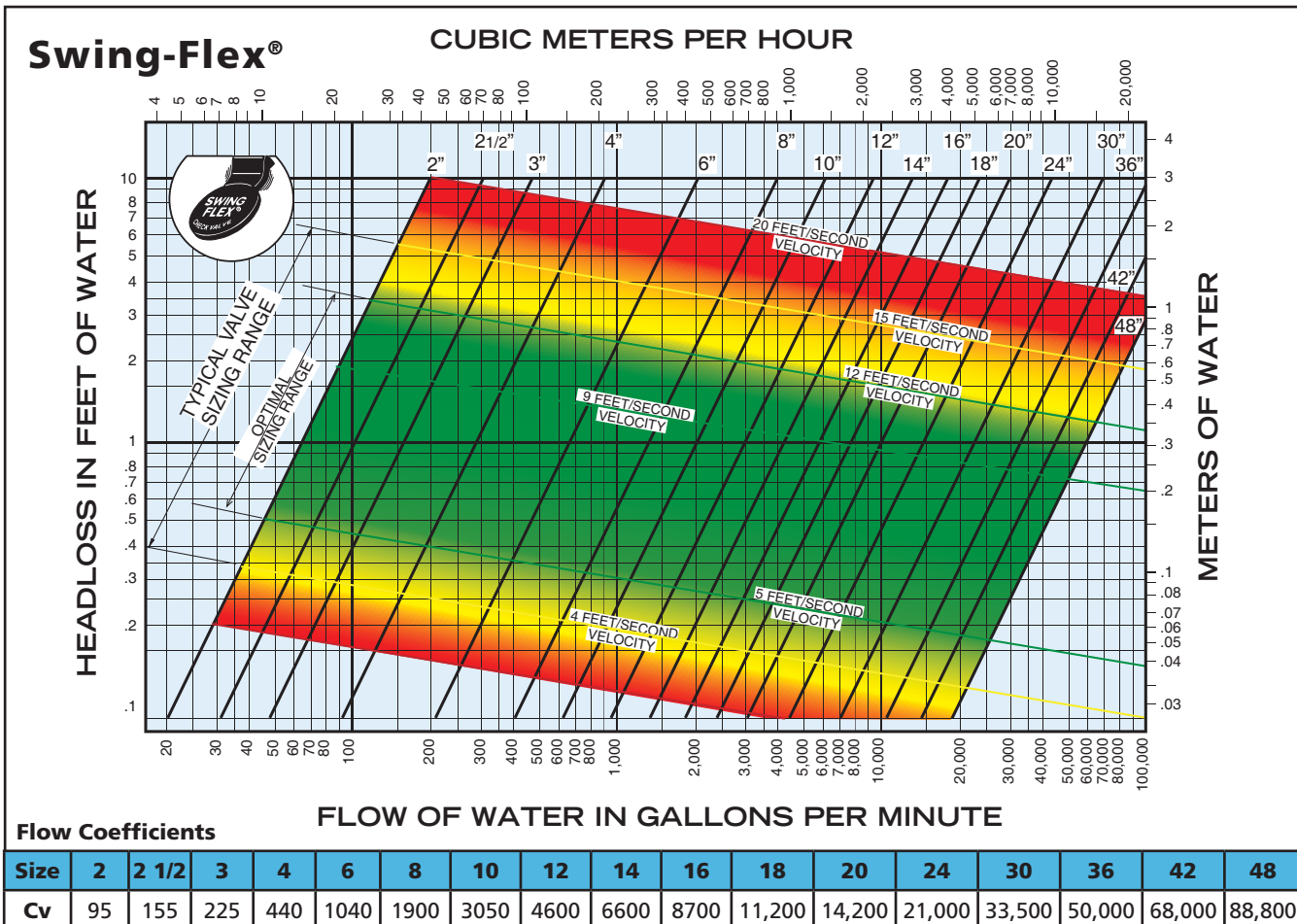

Installation Dimensions

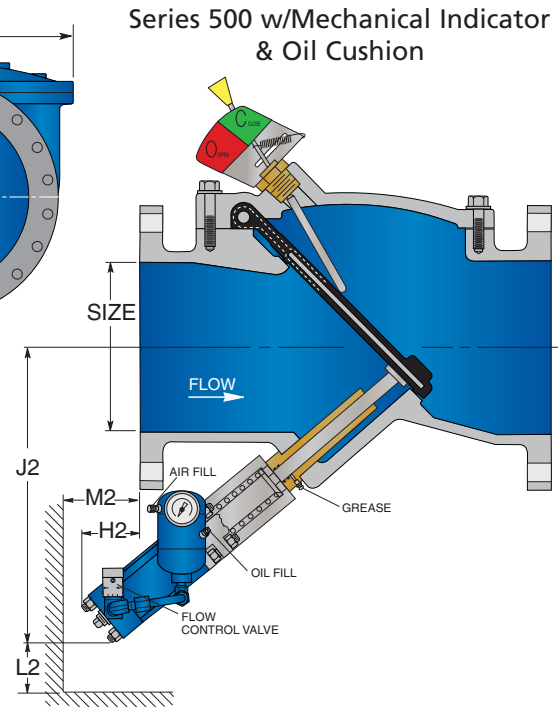
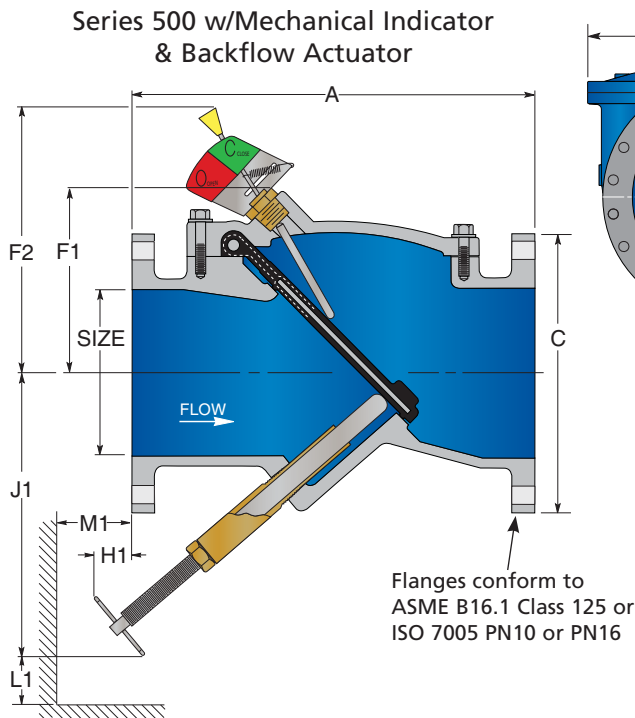

Swing-Flex®
Check Valves

Dimensions in Inches

Valve Size (in)	Valve Size (mm)	CWP (PSI)	Base Valve				with Indicator	with Backflow Actuator				with Oil Cushion				
			Model No.	A	C	F1		K	F2	H1	J1	L1	M1	H2	J2	L2
2	50	250	502A	8.00	6.00	3.38	5.18	-	-0.50	6.75	1.50	1.50	-	-	-	-
2 1/2	60	250	525A	8.50	7.00	3.38	5.18	-	-0.50	7.00	1.50	1.50	-	-	-	-
3	80	250	503A	9.50	7.50	5.13	7.50	8.88	-0.38	7.50	1.50	1.50	-	-	-	-
4	100	250	504A	11.50	9.00	5.75	8.25	9.50	3.38	10.75	2.50	2.50	-	-	-	-
6	150	250	506C	14.00	11.00	6.88	11.13	10.63	1.38	11.38	3.00	3.00	-5.00	16.00	4.25	9.25
8	200	250	508A	19.50	13.50	8.38	16.00	12.25	2.00	15.75	5.75	5.75	-3.25	17.00	5.25	8.50
10	250	250	510A	24.50	16.00	10.75	21.00	14.63	0.50	17.00	5.75	5.75	-1.25	18.00	6.25	7.25
12	300	250	512A	27.50	19.00	12.50	24.00	16.25	3.50	22.50	6.50	6.50	-2.00	20.75	7.25	9.50
14	350	250	514A	31.00	21.00	13.00	23.25	18.88	4.00	26.25	6.50	6.50	0.00	22.75	7.25	7.50
16	400	250	516C	36.00	23.50	14.25	25.25	20.13	4.63	30.00	6.50	6.50	-1.00	24.25	9.00	10.25
18	450	250	518C	40.00	25.00	15.25	28.25	21.25	5.25	33.75	6.50	6.50	1.25	25.25	8.75	7.50
20	500	250	520A	40.00	27.50	16.88	30.63	22.63	5.88	37.50	8.00	8.00	2.75	27.00	9.50	5.25
24	600	250	524A	48.00	32.00	19.25	36.00	25.13	1.81	45.00	8.00	8.00	9.00	27.63	9.75	0.75
30	800	150	530	56.00	38.75	23.00	45.88	28.88	-0.63	41.25	8.00	8.00	8.50	33.63	11.25	3.00
	800	250	530A													
36	900	150	536	63.00	46.00	27.38	55.00	32.25	-0.38	49.00	9.75	9.75	8.25	33.75	15.25	3.00
	900	250	536A													
42	1000	150	542	70.00	53.00	36.88	60.18	40.37	-5.50	53.50	9.75	9.75	14.00	46.00	14.25	1.50
	1000	250	542A													
48	1200	150	548	76.00	59.50	40.66	68.00	43.41	-2.90	41.98	10.00	10.00	-	-	-	-
	1200	250	548A													

Installations



Swing-Flex® Check Valve installed in a Valve Vault



Swing-Flex® Check Valve with Limit Switch



Swing-Flex® Check Valve with Mechanical Indicator installed in a Pump Station











Swing-Flex® Check Valve with Backflow Actuator and Air Valve for Pump Discharge



Swing-Flex® Check Valve with Oil Cushion for Pump Discharge

Options/Accessories

Mechanical Disc Position Indicator	Provides clear indication of the valve's disc position.		Welded Nickel Seat	For severe and abrasive service.	
Limit Switch	Used when applications require remote indication of valve's open/close position.		Tapped Ports	Top and bottom NPT Ports for sampling, pressure testing, and removing sediment.	
Check Light	Provides remote indication from the limit switch.		Rubber Lining	Interior lining suited for systems containing abrasive or corrosive fluids.	
Backflow Actuator	Available for use when manual backflow operation is required.		Glass Lining	Interior lining provides a smooth, non-stick surface.	
Oil Cushion	Hydraulically controls the last 10% of valve closure in 1-5 seconds to reduce water hammer.				

SCOPE

- 1.1 This specification covers the design, manufacture, and testing of 2 in. (50 mm) through 48 in. (1200 mm) Swing-Flex® Check Valves suitable for cold working pressures up to 250 psig (1725 kPa), in water, wastewater, abrasive, and slurry service.
- 1.2 The check valve shall be of the full flow body type, with a domed access cover and only one moving part, the flexible disc.

STANDARDS AND APPROVALS

- 2.1 The valves shall be designed, manufactured and tested to American Water Works Association Standard ANSI/AWWA C508.
- 2.2 The valves used in potable water service shall be certified to NSF/ANSI 61 Drinking Water System Components – Health Effects, and certified to be Lead-Free in accordance with NSF/ANSI 372.
- 2.3 Manufacturer shall have a quality management system that is certified to ISO 9001 by an accredited, certifying body.

CONNECTIONS

- 3.1 The Valves shall be provided with flanges in accordance with ANSI B16.1, Class 125.

DESIGN

- 4.1 The valve body shall be full flow area equal to nominal pipe diameter at all points through the valve. The 4 in. (100mm) valve shall be capable of passing a 3 in. (75mm) solid. The seating surface shall be on a 45 degree angle to minimize disc travel. A threaded port with pipe plug shall be provided on the bottom of the valve to allow for field installation of a backflow actuator or oil cushion device without special tools or removing the valve from the line.
- 4.2 The top access port shall be full size, allowing removal of the disc without removing the valve from the line. The access cover shall be domed in shape to provide flushing action over the disc for operating in lines containing high solids content. A threaded port with pipe plug shall be provided in the access cover to allow for field installation of a mechanical, disc position indicator.
- 4.3 The disc shall be of one-piece construction, precision molded with an integral O-ring type sealing surface and reinforced with alloy steel. The flex portion of the disc contains nylon reinforcement and shall be warranted for twenty-five years. Non-Slam closing characteristics shall be provided through a short 35 degree disc stroke and a memory disc return action to provide a cracking pressure of 0.25 psig.
- 4.4 The valve disc shall be cycle tested 1,000,000 times in accordance with ANSI/AWWA C508 and show no signs of wear, cracking, or distortion to the valve disc or seat and shall remain drop tight at both high and low pressures.

MATERIALS

- 5.1 The valve body and cover shall be constructed of ASTM A536 Grade 65-45-12 ductile iron or ASTM A126 class B gray iron for 30 in. (800mm) and larger. Optional body materials include ASTM A-351 Grade CF8M, stainless steel for sizes 3" (80 mm) through 12" (300 mm).

- 5.2 The disc shall be precision molded Buna-N (NBR), ASTM D2000-BG. Optional disc material includes Viton, EPDM, Hypalon.

OPTIONS

- 6.1 A screw-type backflow actuator shall be provided (when specified) to allow opening of the valve during no-flow conditions. Buna-N seals shall be used to seal the stainless steel stem in a Lead-Free bronze bushing. The backflow device shall be of the rising-stem type to indicate position. A stainless steel T-handle shall be provided for ease of operation.
- 6.2 A mechanical indicator shall be provided (when specified) to provide disc position indication on valves 3" (80 mm) and larger. The indicator shall have continuous contact with the disc under all operating conditions to assure accurate disc position indication.
- 6.3 A pre-wired limit switch will be provided (when specified) to indicate open/closed position to a remote location. The mechanical type limit switch shall be activated by the mechanical indicator. The switch shall be rated for NEMA 4, 6, or 6P and shall have U.L. rated 5 amp, 125 or 250 VAC contacts.
- 6.4 An oil cushion device shall be provided when specified to provide hydraulic control of the final 10% of valve closure and reduce valve slam and water hammer normally associated with rapid flow reversal conditions on pump shut down. The oil cushion device shall consist of a high pressure hydraulic cylinder, adjustable external flow control valve, oil reservoir, pressure gauge, stainless steel air inlet valve, and piping designed to control the closing speed of the last 10% of travel in 1-5 seconds. A threaded lead-free bronze dash-pot bushing unit with a grease fitting for lubrication shall connect the cylinder to the valve and shall have an air gap to prevent hydraulic fluid from entering the valve and contaminating the water system. A snubber rod fitted with O-ring seals and rod wiper scrapers shall make contact with the lower portion of the disc's stainless steel strike plate.
- 6.5 Available linings include rubber for abrasive or corrosive fluids and glass for a smooth, non-stick surface.
- 6.6 A welded nickel seat is available for severe or abrasive service.

MANUFACTURE

- 7.1 Manufacturer shall demonstrate a minimum of five (5) years' experience in the manufacture of resilient, flexible disc check valves with hydraulic cushions.
- 7.2 All valves shall be hydrostatically tested and seat tested to demonstrate zero leakage. When requested, the manufacturer shall provide test certificates, dimensional drawings, parts list drawings, and operation and maintenance manuals.
- 7.3 The exterior and interior of the valve shall be coated with an NSF/ANSI 61 approved fusion bonded epoxy coating.
- 7.4 Swing-Flex® Check Valves shall be Series #500 as manufactured by Val-Matic® Valve & Mfg. Corporation, Elmhurst, IL. USA or approved equal.



Swing-Flex® Check Valve

VAL-MATIC®

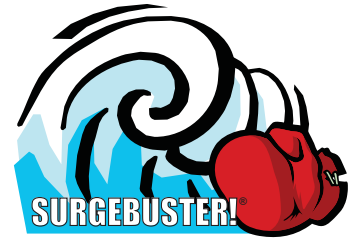

Surgebuster®
Check Valves

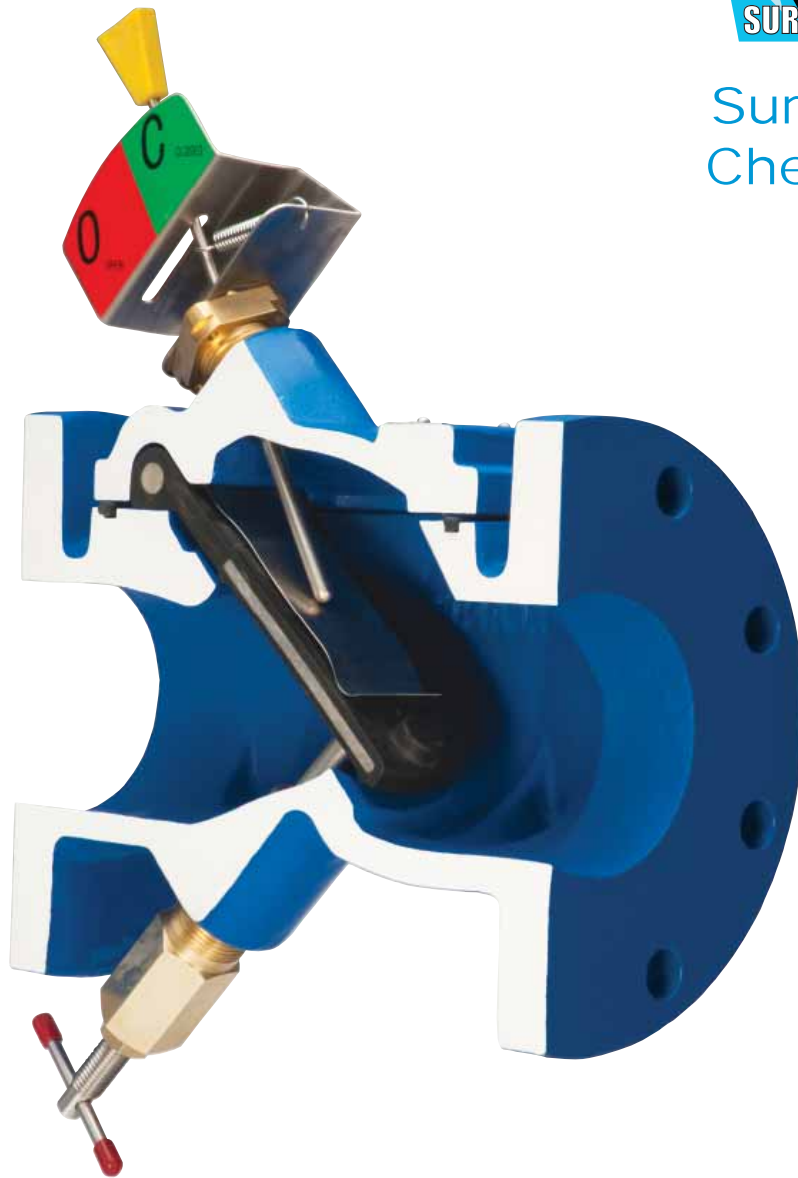

Designed and Manufactured
to AWWA C508
NSF/ANSI 61 & 372 Certified

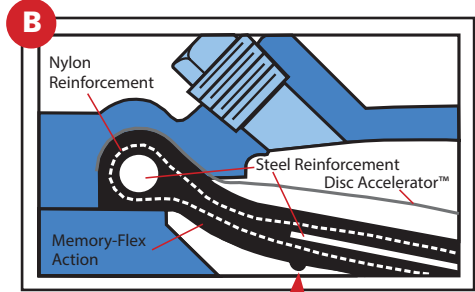
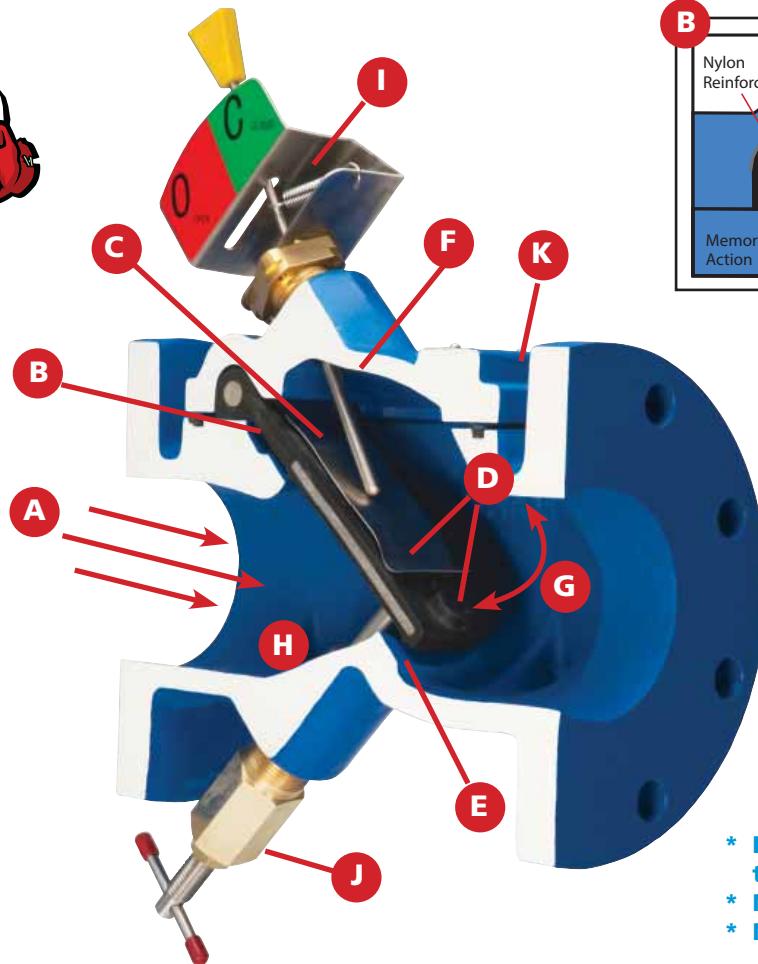

A. Non-Clog Design

100% flow area for improved flow characteristics and lower headloss. Unrestricted flow area combined with smooth streamlined contouring allows passage of large solids minimizing the potential for clogging.

B. Reinforced Disc

The one piece precision molded disc is steel and nylon reinforced to provide years of trouble free performance. It is backed by a 25 year warranty for the flex portion of the disc.

C. Disc Accelerator™

The signature Surgebuster® Disc Accelerator™ moves in perfect tandem with the reinforced disc to quickly and efficiently speed the closure of the disc.

D. Two Moving Parts

The Memory-Flex™ disc and the Disc Accelerator™ are the only moving parts. There are no pack-

ing, mechanical hinges, pivot pins or bearings to wear out. Hinge portion of the disc is warranted for 25 years.

E. Drop Tight Seating

The synthetic reinforced disc, with its integral O-ring type seal design assures positive seating at high and low pressures.

F. Domed Access Port

Full size top access port allows removal of disc without removing the valve from the line and provides flushing action over the valve disc for clog free performance. Access cover includes a drilled and tapped port for installation of optional Disc Position Indicator.

G. Non-Slam Closure

"Short Disc Stroke" combined with Memory-Flex™ Disc Action and Disc Accelerator™ to reduce potentially destructive water hammer.

- * Designed and Manufactured to AWWA C508
- * NSF/ANSI 61 Certified
- * NSF/ANSI 372 Certified

H. Fusion Bonded Epoxy

Fusion Bonded Epoxy (FBE) is the standard coating on the interior and exterior of the valve to provide superior corrosion and wear resistance.

I. Mechanical Disc Position Indicator

Provides clear indication of the valve's disc position. Can also be provided with a SCADA compatible limit switch for off site monitoring. (Optional)

J. Backflow Actuator

Body is drilled and tapped for installation of backflow actuator. Available for use when manual backflow operation is required. Most commonly used for priming pumps, back flushing, draining lines and system testing. (Optional)

K. Cover Bolts

Bolting is stainless steel for corrosion resistance in harsh environments.

Innovative Design

Pumping applications with high head, surge tanks, or multiple pumps, have long proved a challenge to system operators trying to minimize line surges resulting from slamming check valves.

Only one real cause exists for slamming check valves -- reverse flow. The impact of the reverse flow is direct and proportional; the faster the reverse flow, the more violent the slam. If reverse flow through the check valve is allowed to develop, the reverse flow will slam the disc into the seat and create a loud water hammer or surge.

Now system operators have the solution... Surgebuster®.

Optimum Performance

The Surgebuster® achieves rapid closure through a short disc stroke of 35° and adjustable Disc Accelerator™. The short disc stroke is less than half the typical 80° to 90° stroke of a conventional swing check valve. It is achieved by placing the valve seat on a 45° angle while maintaining a full flow area equal

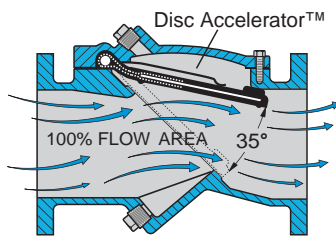

Figure 1. Val-Matic Surgebuster® Valve

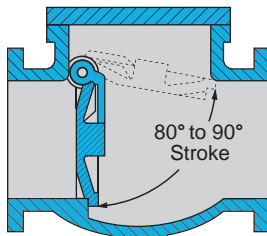

Figure 2. Conventional Swing Check Valve

to the mating pipe (Figures 1 & 2).

The Disc Accelerator™ is a precision formed stainless steel mechanism that closes the valve disc rapidly thus avoiding slamming by flow reversal and allowing the disc to be stabilized under flow conditions. The accelerator is fully enclosed within the valve and completely out of the flow path (Figure 1).

Traditional swing check valves use outside levers with weights or springs in an attempt to reduce slam. By

doing so, they force the disc into the flow and reduce the length of the disc stroke so that it closes faster.

Unfortunately, while outside levers and weights help solve one problem, they create two others. Increased headloss and maintenance are inevitable with traditional swing check valves. Pulling the disc down into the flow creates a blockage in the line and causes tremendous headloss and turbulence. With the disc oscillating in the flow, the shaft, bearings, and shaft seal are all subjected to increased wear and reduced service life.

In many applications, this approach has proven ineffective and led to the addition of an air cushion cylinder, which is attached to the weight or spring powered lever. Conversely, the traditional air cushion slows the disc travel allowing reverse flow to increase. The end result, especially on fast flow reversal systems, is a slamming check valve and water hammer.

The Surgebuster® with its short 35° stroke and Disc Accelerator™ provide fast closure thereby preventing slam and the resultant surge without obstructing flow or the need for maintenance. Val-Matic is so confident in the Surgebuster's non-slam performance that we guarantee* the valve will out perform any air cushion swing check valve with weight and lever.

Advanced Technology

Incorporating the latest in valve technology assures a high-quality valve that will provide long service. The design process utilized solid Modeling and Finite Element Analysis (FEA) of the key structural components. Flow and headloss data was derived from flow tests, mathematical models and Computational Fluid Dynamics (CFD). Manufacturing technology uses automated process control in the foundry and ISO 9001 controlled manufacturing processes.

Product Certifications

Val-Matic Surgebuster® check valves are certified for use in drinking water in accordance with NSF/ANSI 61 and are Certified Lead-Free per NSF/ANSI 372. All valves are tested on automated hydraulic test rigs with gauges calibrated per ISO standards. All Val-Matic Valves are manufactured under a certified ISO 9001 quality management system.

* Warranty details available upon request.

PRESSURE RATINGS

MAXIMUM PRESSURE RATINGS		
SIZE RANGE in (mm)	CONNECTION	CWP psig (Bar)
2" - 24" (50-600 mm)	ANSI Class 125 Ductile Iron	250 (17.2)
30" - 48" (800-1200 mm)	ANSI Class 125 Cast Iron	150 (10.3)
30" - 48" (800-1200 mm)	ANSI Class 125 Ductile Iron	250 (17.2)

MATERIALS OF CONSTRUCTION

COMPONENT	STANDARD	OPTIONAL
Body 2" - 24" (50-600 mm)	Ductile Iron ASTM A536, Grade 65-45-12	ASTM A351, CF8M 316 SS 3" - 12" (80-300 mm)
Body 30" - 48" (800-1200 mm)	Ductile Iron ASTM A536, Grade 65-45-12	Cast Iron ASTM A126, Class B
Disc	Buna-N w/Alloy Steel & Nylon Reinforcement	EPDM, Hypalon, Viton
Disc Accelerator	ASTM A666 T302 Stainless Steel	-
Coatings	Fusion Bonded Epoxy (Int/Ext)	Rubber Lining, Glass Lining
Mechanical Indicator (Optional)	17-4 Stainless Steel, Lead-Free Bronze	-
Backflow Actuator (Optional)	17-4 Stainless Steel, Lead-Free Bronze	-

AWWA Note: If the purchaser specifies a wetted component that was not tested and certified to NSF/ANSI 61, the certification may not be valid.

Headloss Chart

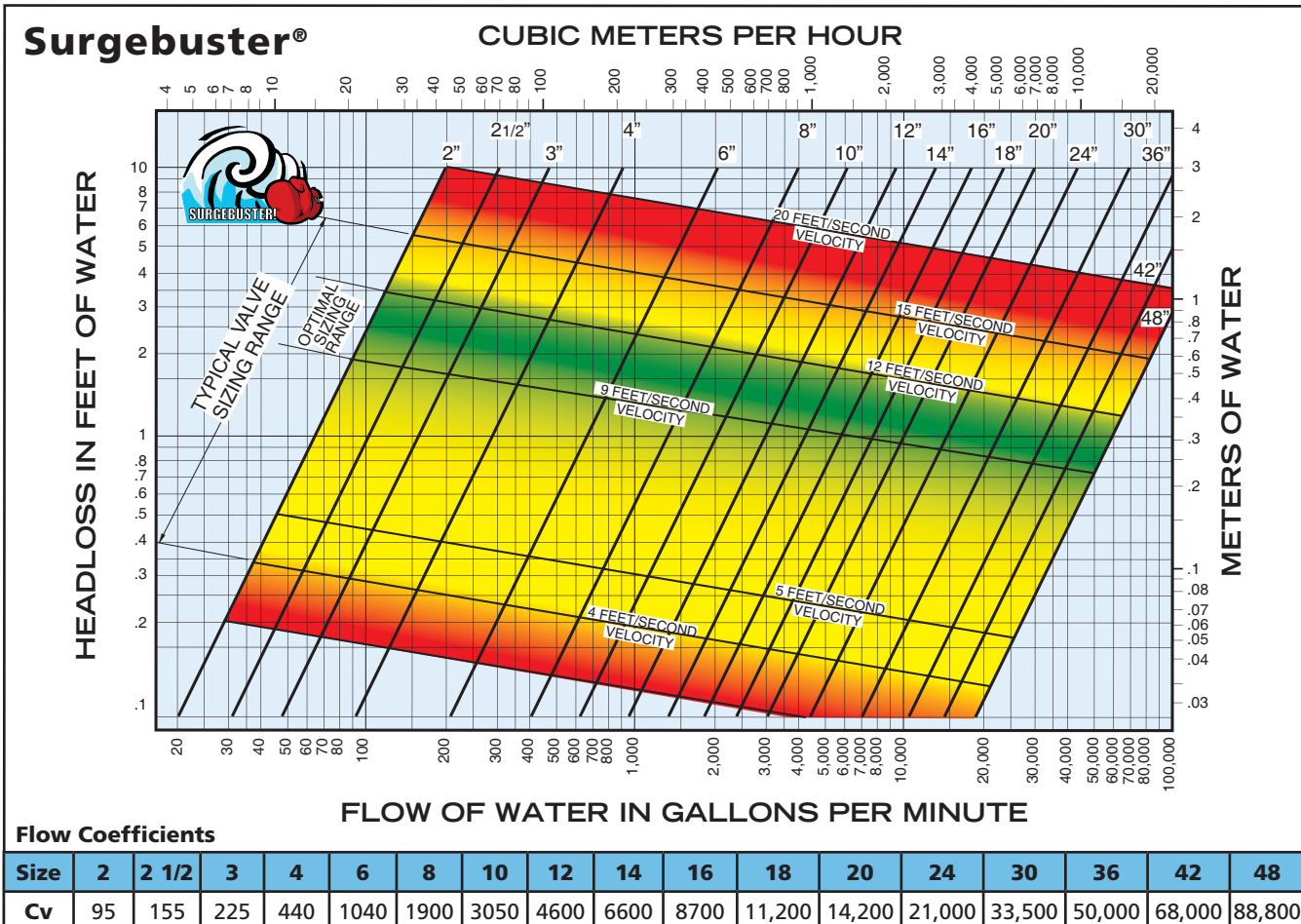

Installation Dimensions

Series 7200 w/Mechanical Indicator & Backflow Actuator

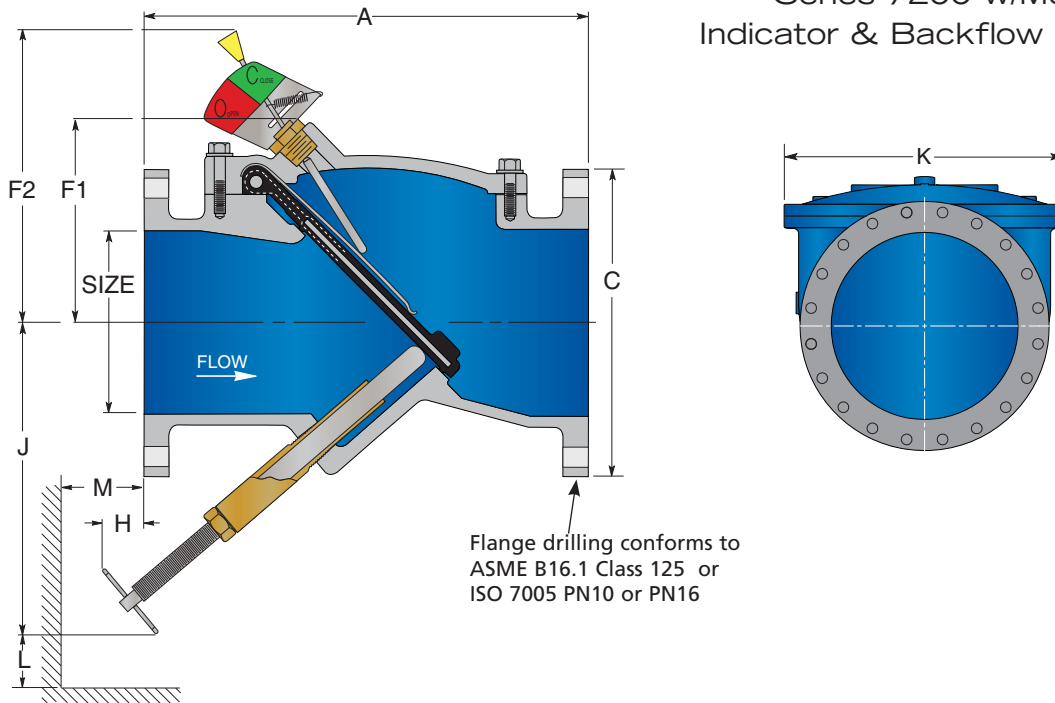

Dimensions in Inches												
Valve Size (in)	Valve Size (mm)	CWP (PSI)	Base Valve				with Indicator	with Backflow Actuator				
			Model No.	A	C	F1	K	F2	H	J	L	M
2	50	250	7202	8.00	6.00	3.38	5.18	-	-0.50	6.75	1.50	1.50
2 1/2	60	250	7225	8.50	7.00	3.38	5.18	-	-0.50	7.00	1.50	1.50
3	80	250	7203	9.50	7.50	5.13	7.50	8.88	-0.38	7.50	1.50	1.50
4	100	250	7204	11.50	9.00	5.75	8.25	9.50	3.38	10.75	2.50	2.50
6	150	250	7206C	14.00	11.00	6.88	11.13	10.63	1.38	11.38	3.00	3.00
8	200	250	7208	19.50	13.50	8.38	16.00	12.25	2.00	15.75	5.75	5.75
10	250	250	7210	24.50	16.00	10.75	21.00	14.63	0.50	17.00	5.75	5.75
12	300	250	7212	27.50	19.00	12.50	24.00	16.25	3.50	22.50	6.50	6.50
14	350	250	7214	31.00	21.00	13.00	23.25	18.88	4.00	26.25	6.50	6.50
16	400	250	7216C	36.00	23.50	14.25	25.25	20.13	4.63	30.00	6.50	6.50
18	450	250	7218C	40.00	25.00	15.25	28.25	21.25	5.25	33.75	6.50	6.50
20	500	250	7220	40.00	27.50	16.88	30.63	22.63	5.88	37.50	8.00	8.00
24	600	250	7224	48.00	32.00	19.25	36.00	25.13	1.81	45.00	8.00	8.00
30	800	150	7230	56.00	38.75	23.00	45.88	28.88	-0.63	41.25	8.00	8.00
	800	250	7230A									
36	900	150	7236	63.00	46.00	27.38	55.00	32.25	-0.38	49.00	9.75	9.75
	900	250	7236A									
42	1000	150	7242	70.00	53.00	36.88	60.18	40.37	-5.50	53.50	9.75	9.75
	1000	250	7242A									
48	1200	150	7248	76.00	59.50	40.66	68.00	43.41	-2.90	41.98	10.00	10.00
	1200	250	7248A									

Dynamic Testing of Check Valves

Surgebuster® and Conventional Air Cushioned Swing Check Valves were flow tested under identical dynamic conditions and the downstream pressure plotted as shown in Figures 1 and 2. The valves were installed on the discharge of a four-inch 20 HP water pump and connected to a hydro-pneumatic tank charged to 30 psig. After pump shutdown, the water flow would rapidly reverse in about 1/2 second and cause rapid valve closure.

The Air Cushioned Swing Check Valve was equipped with a lever, weight and air cushion with flow control valve. Despite an operating velocity over 8 feet per second, the Cushioned Swing Check Valve traveled only 15° or about 25% open. Partially open check valves are common and can cause excessive headloss and energy consumption. Adjustments to the air cushion slowed down the valve closure and magnified the valve slam. In Figure 1, the valve closed with a loud slam and produced an upsurge

in the downstream piping of 150 psi over the static pressure.

The Surgebuster® was operated under the same flow conditions and was found to open 35° or 100% open. In Figure 2, after pump shutdown the Surgebuster® closed with a negligible slam and produced an upsurge in the downstream piping of only 25 psi over the static pressure.

The dynamic tests demonstrate that the Surgebuster® can reduce check valve slam up to 80% when compared to conventional swing check valves. Numerous field installations with vertical lines, multiple pumps, and high pump discharge head all exhibited the same result. The Surgebuster® provides non-slam operation with reduced headloss and maintenance.

*Video test results available at www.valmatic.com.

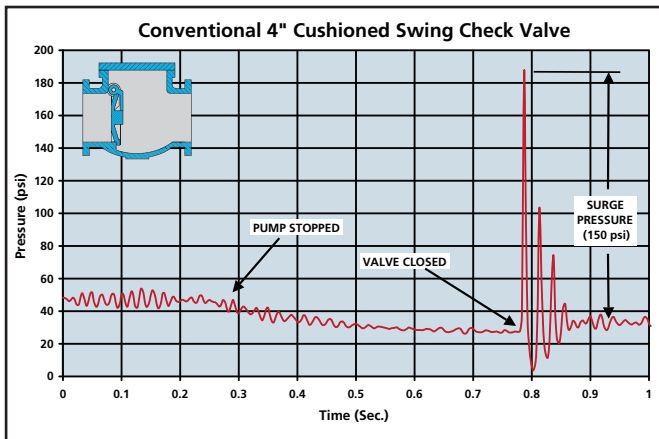

Figure 1. The conventional air cushioned swing check valve closed with a loud slam producing a 150 psi surge with optimum cushion adjustment.

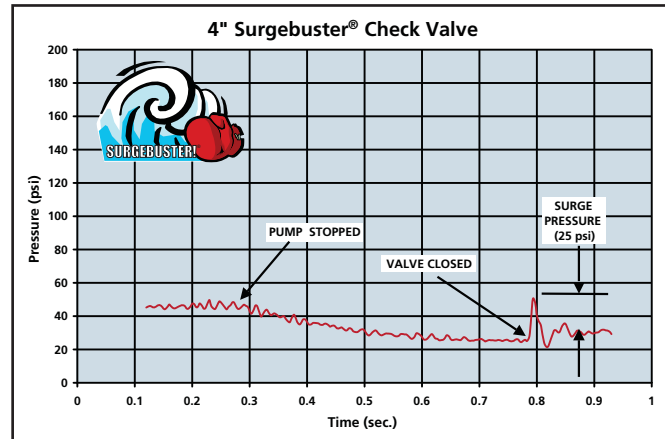







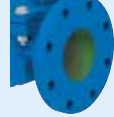

Figure 2. The Surgebuster® closed quietly producing a 25 psi surge pressure, 80% less than the conventional air cushioned swing check valve.

Options/Accessories

Mechanical Disc Position Indicator	Provides clear indication of the valve's disc position.		Welded Nickel Seat	For severe and abrasive service.	
Limit Switch	Used when applications require remote indication of valve's open/close position.		Tapped Ports	Top and bottom NPT Ports for sampling, pressure testing, and removing sediment.	
Check Light	Provides remote indication from the limit switch.		Rubber Lining	Interior lining suited for systems containing abrasive or corrosive fluids.	
Backflow Actuator	Available for use when manual backflow operation is required.		Glass Lining	Interior lining provides a smooth, non-stick surface.	

SCOPE

- 1.1 This specification covers the design, manufacture, and testing of 2 in. (50 mm) through 48 in. (1200 mm) Surgebuster® Swing Check Valves suitable for cold working pressures up to 250 psig (1725 kPa), in water, wastewater, abrasive, and slurry service.
- 1.2 The check valve shall be of the full flow body type, with a domed access cover and only two moving parts, the flexible disc and the Disc Accelerator™.

STANDARDS AND APPROVALS

- 2.1 The valves shall be designed, manufactured and tested to American Water Works Association Standard ANSI/AWWA C508.
- 2.2 The valves used in potable water service shall be certified to NSF/ANSI 61 Drinking Water System Components – Health Effects, and certified to be Lead-Free in accordance with NSF/ANSI 372.
- 2.3 Manufacturer shall have a quality management system that is certified to ISO 9001 by an accredited, certifying body.

CONNECTIONS

- 3.1 The Valves shall be provided with flanges drilled in accordance with ANSI B16.1, Class 125.

DESIGN

- 4.1 The valve body shall have a full flow area equal to nominal pipe area at all points through the valve. The 4 in. (100mm) valve shall be capable of passing a 3 in. (75mm) solid. The seating surface shall be on a 45 degree angle to minimize disc travel. A threaded port with pipe plug shall be provided on the bottom of the valve to allow for field installation of a backflow actuator or oil cushion device without special tools or removing the valve from the line.
- 4.2 The top access port shall be full size, allowing removal of the disc without removing the valve from the line. The access cover shall be domed in shape to provide flushing action over the disc for operating in lines containing high solids content. A threaded port with pipe plug shall be provided in the access cover to allow for field installation of a mechanical, disc position indicator.
- 4.3 The disc shall be of one-piece construction, precision molded with an integral O-ring type sealing surface and reinforced with alloy steel. The flex portion of the disc shall contain nylon reinforcement and shall be warranted for twenty-five years. Non-Slam closing characteristics shall be provided through a short 35 degree disc stroke and a disc accelerator to provide a cracking pressure of 0.3 psig.
- 4.4 The disc accelerator shall be of one piece construction and provide rapid closure of the valve in high head applications. The disc accelerator shall be enclosed within the valve and shall be field adjustable and replaceable without removal of the valve from the line. The disc accelerator shall be securely held in place captured between the cover and disc. It shall be formed with a large radius to allow smooth movement over the disc surface.

- 4.5 The valve disc shall be cycle tested 1,000,000 times in accordance with ANSI/AWWA C508 and show no signs of wear, cracking, or distortion to the valve disc or seat and shall remain drop tight at both high and low pressures.

MATERIALS

- 5.1 The valve body and cover shall be constructed of ASTM A536 Grade 65-45-12 ductile iron or ASTM A126 class B gray iron for 30 in. (800mm) and larger. Optional body materials include ASTM A-351 Grade CF8M, stainless steel for sizes 3" (80 mm) through 12" (300 mm).
- 5.2 The disc shall be precision molded Buna-N (NBR), ASTM D2000-BG. Optional disc material includes Viton, EPDM, Hypalon.
- 5.3 The disc accelerator shall be Type 302 stainless steel.

OPTIONS

- 6.1 A screw-type backflow actuator shall be provided (when specified) to allow opening of the valve during no-flow conditions. Buna-N seals shall be used to seal the stainless steel stem in a Lead-Free bronze bushing. The backflow device shall be of the rising-stem type to indicate position. A stainless steel T-handle shall be provided for ease of operation.
- 6.2 A mechanical indicator shall be provided (when specified) to provide disc position indication on valves 3" (80 mm) and larger. The indicator shall have continuous contact with the disc under all operating conditions to assure accurate disc position indication.
- 6.3 A pre-wired limit switch will be provided (when specified) to indicate open/closed position to a remote location. The mechanical type limit switch shall be activated by the mechanical indicator. The switch shall be rated for NEMA 4, 6, or 6P and shall have U.L. rated 5 amp, 125 or 250 VAC contacts.
- 6.4 Available linings include rubber for abrasive or corrosive fluids and glass for a smooth, non-stick surface.
- 6.5 A welded nickel seat is available for severe or abrasive service.

MANUFACTURE

- 7.1 Manufacturer shall demonstrate a minimum of five (5) years' experience in the manufacture of resilient, flexible disc check valves with hydraulic cushions.
- 7.2 All valves shall be hydrostatically tested and seat tested to demonstrate zero leakage. When requested, the manufacturer shall provide test certificates, dimensional drawings, parts list drawings, and operation and maintenance manuals.
- 7.3 The exterior and interior of the valve shall be coated with an NSF/ANSI 61 approved fusion bonded epoxy coating.
- 7.4 Surgebuster® Swing Check Valves shall be Series #7200 as manufactured by Val-Matic® Valve & Mfg. Corporation, Elmhurst, IL. USA or approved equal.



Surgebuster® Check Valves



VAL-MATIC®

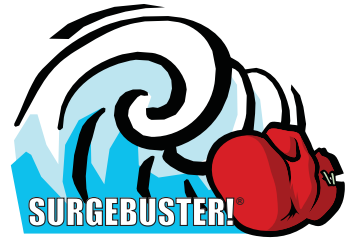

Surgebuster® NXT Check Valves

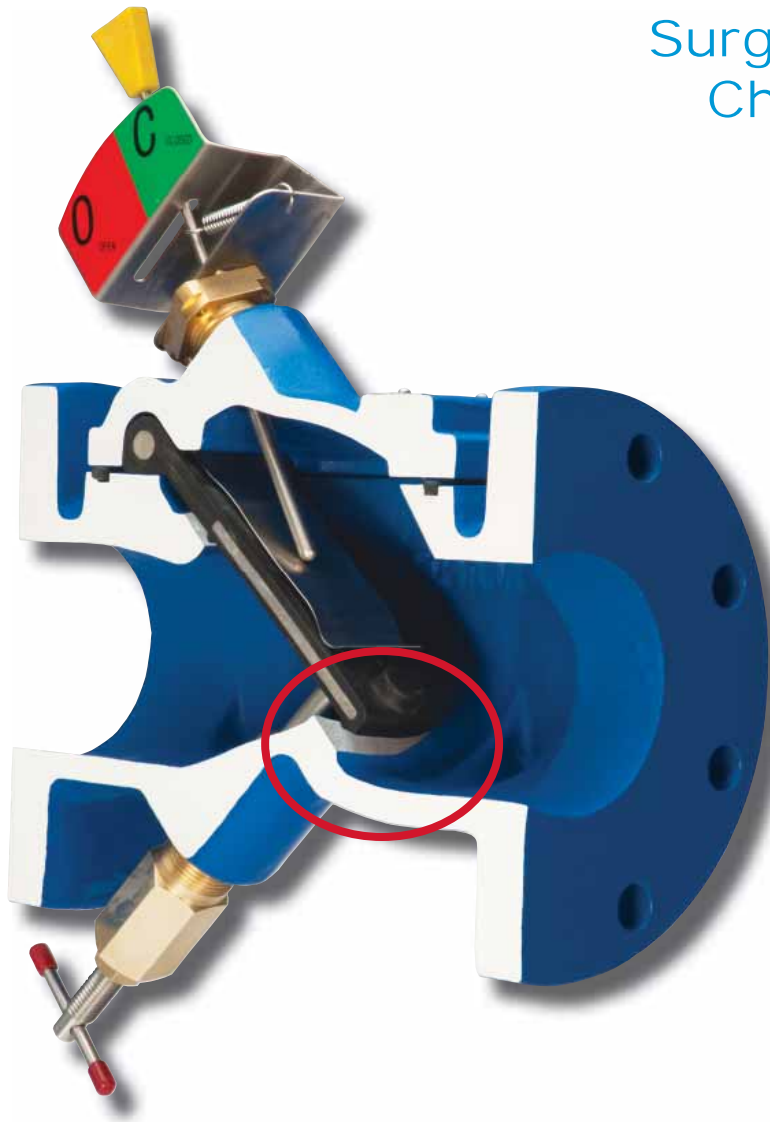

Designed and Manufactured
to AWWA C508
NSF/ANSI 61 & 372 Certified

Surgebuster® NXT Check Valves

The Surgebuster® NXT Check Valve is an excellent choice for water, wastewater slurries, sludge, and vertical flow up applications. The nickel welded seat is ideal for long life in severe and abrasive service.

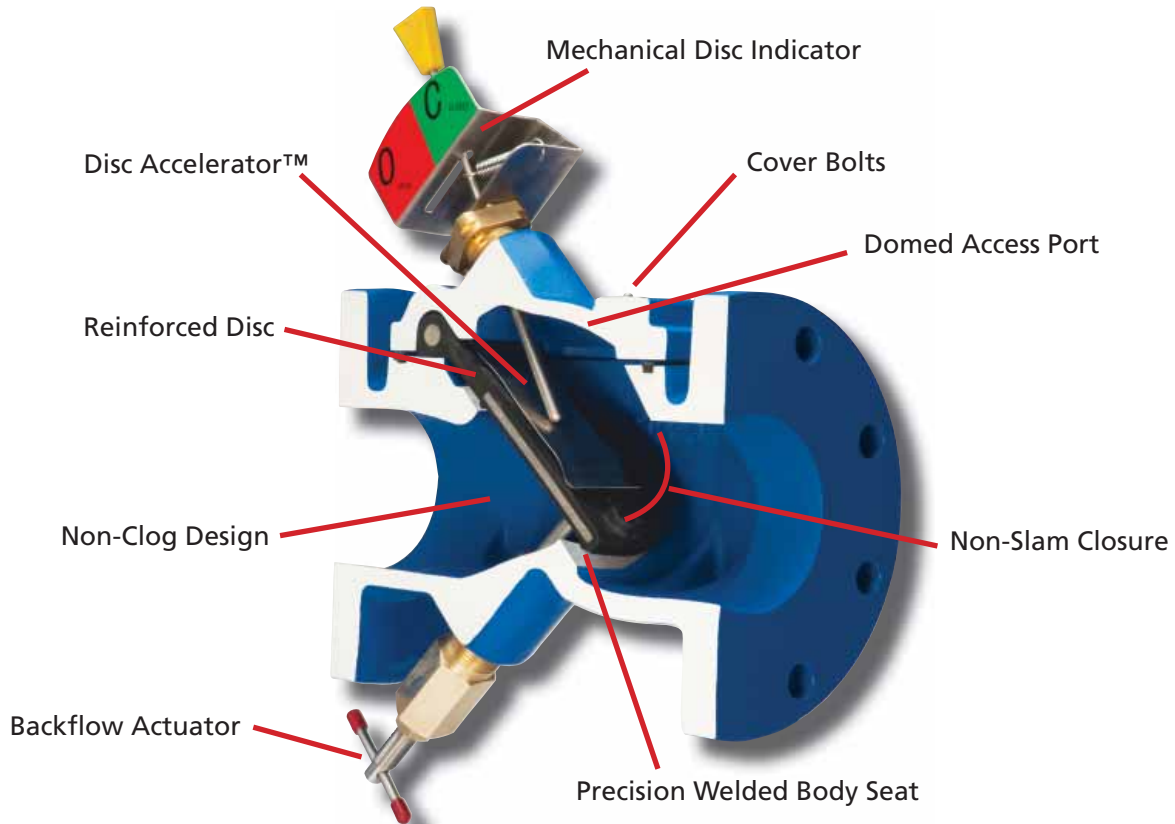

Preferred Features

Construction and Sizing

Ductile iron construction available in sizes 2" - 48".

Non-Clog Design

100% flow area for improved flow characteristics and lower headloss.

Reinforced Disc

One piece precision molded disc is steel and nylon reinforced for trouble free performance.

Disc Accelerator™

Moves in perfect tandem with the reinforced disc to quickly and efficiently speed the closure of the disc.

Precision Welded Body Seat

1/16" Nickel Welded Overlay adds durability for severe or abrasive applications and ensures a long lasting seal.

Mechanical Disc Indicator

Provides clear indication of the valve's disc position.

Domed Access Port

Full size top access port allows removal of the disc without removing the valve from the line.

Non-Slam Closure

"Short Disc Stroke" combined with Memory-Flex™ Disc Action and Disc Accelerator™ to reduce potentially destructive water hammer.

Cover Bolts

T316 stainless steel for corrosion resistance in harsh environments.

Backflow Actuator

Most commonly used for priming pumps, back flushing, draining lines and system testing.

Coating

Fusion Bonded Epoxy (FBE) is the standard on the interior and exterior of the valve. The FBE is NSF/ANSI 61 certified.

Innovative Design

Pumping applications with high head, surge tanks or multiple pumps have long proved to be a challenge for system operators trying to minimize line surges resulting from slamming check valves.

Only one real cause exists for slamming check valves -- reverse flow. The impact of the reverse flow is direct and proportional; the faster the reverse flow, the more violent the slam. If reverse flow through the check valve is allowed to develop, the reverse flow will slam the disc into the seat and create a loud water hammer or surge. Now system operators have discovered the solution...The Surgebuster® Check Valve.

Optimum Performance

The Surgebuster® achieves rapid closure through a short disc stroke of 35° and adjustable Disc Accelerator™. The short disc stroke is less than half the typical 80° to 90° stroke of a conventional swing check valve. It is achieved by placing the valve seat on a 45° angle while maintaining a full flow area equal to that of the mating pipe (Figures 1 & 2).

The Disc Accelerator™ is a precision formed stainless steel mechanism that closes the valve disc rapidly thus avoiding slamming by flow reversal and allowing the disc to be stabilized under flow conditions. The accelerator is fully enclosed within the valve and completely out of the flow path (Figure 1).

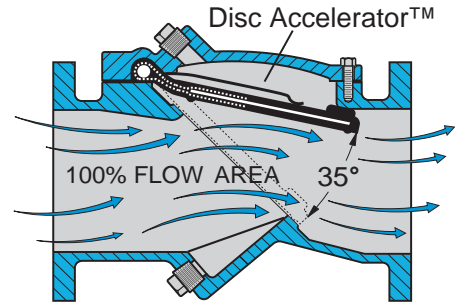

Figure 1. Val-Matic Surgebuster® Check Valve

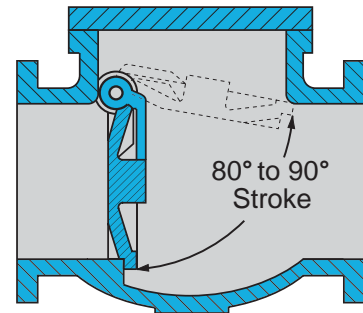

Figure 2. Conventional Swing Check Valve

Surgebuster®
Check Valves

Applications

The Surgebuster® Check Valve is excellent in a number of applications, including high head, multiple pump and surge tank installations. The Surgebuster® is designed for the harshest environments and applications.

Installations

- Pulp/Paper
- Sludge
- Potable Water
- Salt Water, Sea Water, Brine
- Raw and Screened Sewage
- Abrasive Slurries, Mining, Bottom Ash

Applications

- High Head
- Multiple Pump
- High Pressure
- Cooling
- Irrigation
- Surge Mitigation
- Vertical Flow Up
- Fracking, Dewatering
- Surge Tank Installations



Crystal Springs Pump Station
Roanoke, VA



Surgebuster® NXT Check Valve



Silent Check Valves



Certified Lead-Free
NSF/ANSI 61 & 372 Certified

Threaded

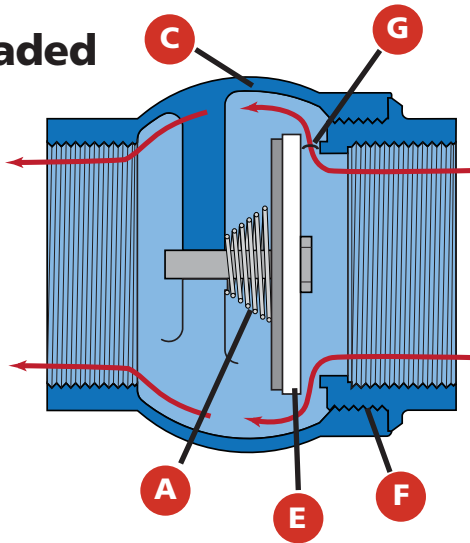

Wafer

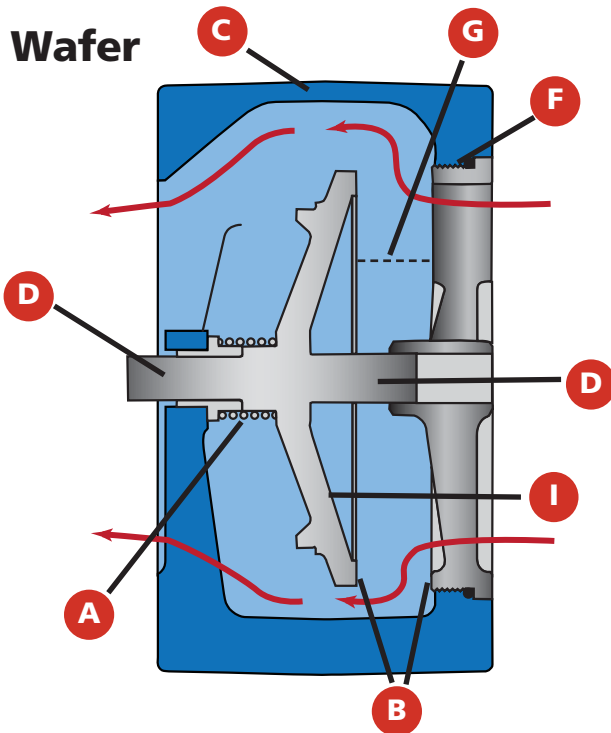

Globe

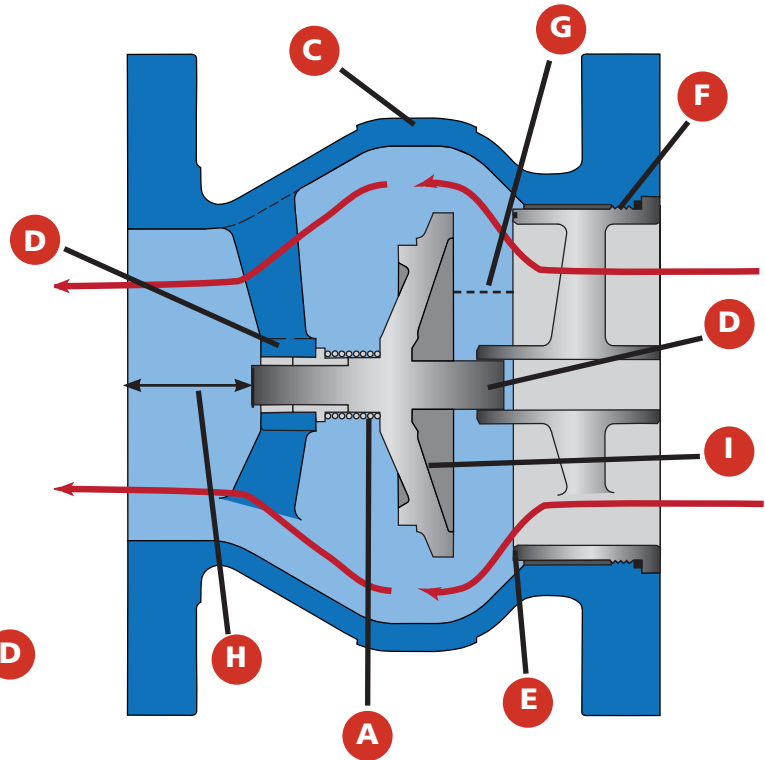

A. Heavy Duty Spring

Tested over 100,000 cycles to ensure valve dependability and non-slam closure.

B. Metal-to-Metal Seating

For durability and extended life. Corrosion free seat and disc sealing surfaces are precision-machined flat and smooth to meet AWWA and MSS metal seat leakage criteria.

C. Expanded Flow Area

Tear-drop contour reduces headloss and provides energy savings.

D. Double Guided Disc

Prevents vibration and wear, ensuring long valve life.

E. Resilient Seat

Provides zero leakage. Standard on Threaded style, optional on Wafer and Globe styles.

F. Threaded Seat

12 in. and smaller seats are threaded to secure the seat at full rated pressure.

G. Short Stroke

The combination of short stroke and spring return assures non-slam closure.

H. Mate-ability

Globe style sizes 2½ through 10 in. mate to wafer style butterfly valves without the use of spool pieces.

I. Concave Disc

The disc is concave to provide for disc stabilization, maximum strength and a minimum flow velocity to open the valve.

The Val-Matic Silent Check Valve has been the preferred choice by users for over 50 years. Its silent operation, low cost and proven performance in clean water applications have made it a preferred choice by design engineers and system operators.

Silent Operation

The Silent Check Valve is preferred over other types of valves because of its silent operation which reduces shock and water hammer. The Silent Check Valve is the fastest closing check valve because of its short stroke and spring-assisted closure. When flow occurs, the disc is lifted off the seat to allow forward flow. When the pump is stopped, the spring in the valve forces the disc closed before flow reverses, providing silent closure. Dynamic check valve tests show that surge pressure is significantly reduced when a silent check valve is used. (See Figures 1 & 2)

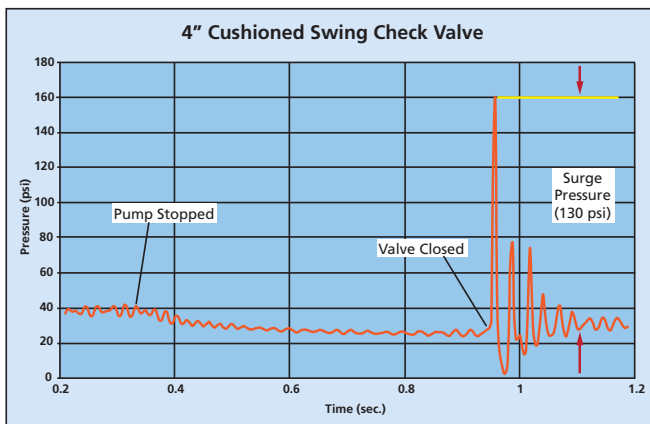

Figure 1 - Cushioned Swing Check Valve Dynamic Test Results

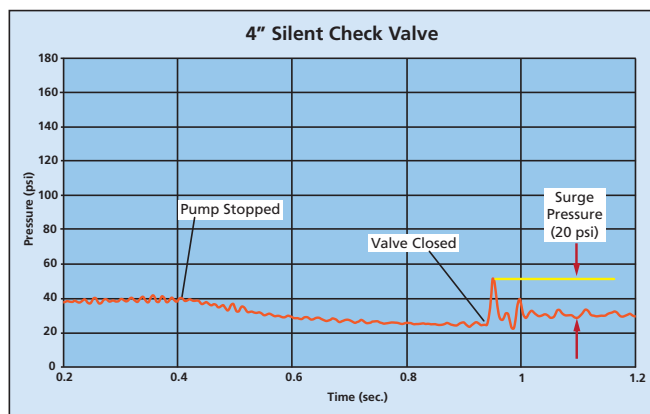

Figure 2 - Silent Check Valve Dynamic Test Results

Optional Resilient Seat

The Val-Matic Wafer and Globe Silent Check Valves are available with an optional O-ring seat design that provides zero leakage at both high and low pressures. (See Figure 3) The unique seat design cavity is tapered to secure the seal under flowing conditions.

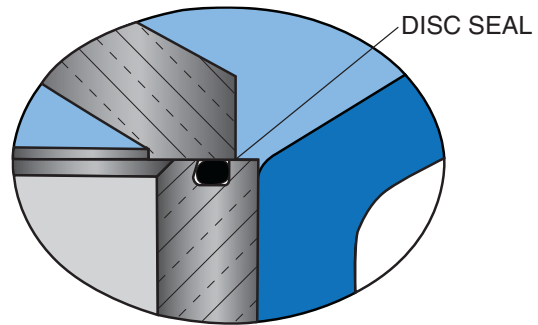

Figure 3 - Resilient Seating Detail

Installation Versatility

The design of the valve allows operation in any installation position. All three styles of Silent Check Valves can be installed in either horizontal or vertical lines with the flow up or down. Valves 14 in. and larger require a severe duty spring for flow down applications. Wafer sizes 2 - 6 in. are dual rated to fit between both ASME B16.1 Class 125 and 250 flanges. In applications where space is limited, the compact wafer style is the preferred choice. 12 in. and smaller valves with threaded seats can be installed directly adjacent to expansion joints and couplings without relying on the mating flange to support the seat.

Corrosion-Resistant Construction

Wafer and globe style valves are available in all stainless steel construction in accordance with ASME B16.34, Class 150 requirements. The cast austenitic stainless steel construction provides a high level of corrosion resistance for chemical, mining, pulp and paper, and other general industry applications.

Product Certifications

Val-Matic Silent Check Valves are NSF/ANSI 372 certified Lead-Free. Wafer and globe style valves are NSF/ANSI 61 certified for drinking water. Wafer style (2-10 in.) and globe style (2½-12 in.) Silent Check Valves are Factory Mutual approved for use in fire protection systems. All Val-Matic Valves are manufactured under a certified ISO 9001 quality management system.

Silent Check Valves

Installation Dimensions

Series 1400THR - Threaded

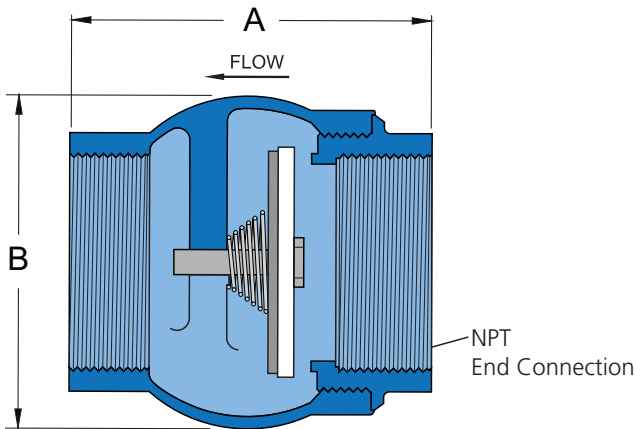

Dimensions				
Valve Size (NPT)	CWP psig (Bar)	A in (mm)	B in (mm)	Weight lb (kg)
1/2	250 (17.2)	2.06 (52.3)	1.38 (35.0)	.38 (.17)
3/4	250 (17.2)	2.25 (57.1)	1.63 (41.4)	.48 (.22)
1	250 (17.2)	2.63 (66.8)	2.00 (50.8)	.81 (.37)
1 1/4	250 (17.2)	2.94 (74.6)	2.38 (60.4)	1.22 (.55)
1 1/2	250 (17.2)	3.31 (84)	2.75 (69.8)	1.61 (.73)
2	250 (17.2)	3.68 (93.4)	3.38 (85.8)	5.13 (2.33)

Series 1400A - Wafer

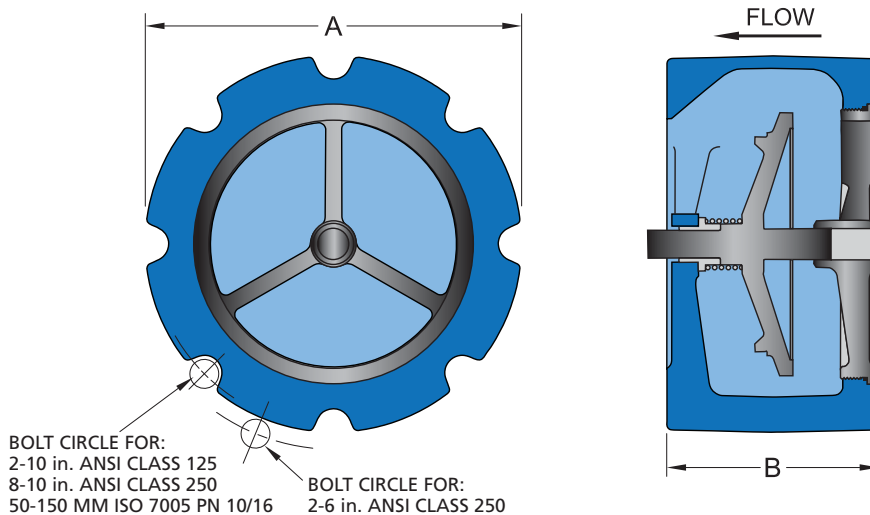

Dimensions - Inch					
Valve Size	CWP (psig)	ANSI Class	A	B	Weight (lb)
2*	400	125/250	4.25	2.63	6
2 1/2*	400	125/250	5.00	2.88	7
3*	400	125/250	5.75	3.13	11
4*	400	125/250	7.00	4.00	19
5*	400	125/250	8.75	4.75	28
6*	400	125/250	9.75	5.50	41
8	200	125	13.38	6.50	81
	400	250	13.38	6.50	89
10	200	125	16.00	8.25	99
	400	250	16.00	8.25	137

Dimensions - Metric					
Valve Size	CWP (Bar)	PN Class	A	B	Weight (kg)
50	27.6	10/16	107.9	66.8	3
65	27.6	10/16	127	73.1	4
80	27.6	10/16	146	79.5	5
100	27.6	10/16	177.8	101.6	9
125	27.6	10/16	222.2	107.9	13
150	27.6	10/16	247.6	139.7	19
200	27.6	16	342.9	165.1	40
250	27.6	16	406.4	215.9	62

*Note: Sizes 2 - 6 in. are dual rated to fit between both ANSI Class 125 and 250 flanges.

Installation Dimensions

Series 1800 - Globe

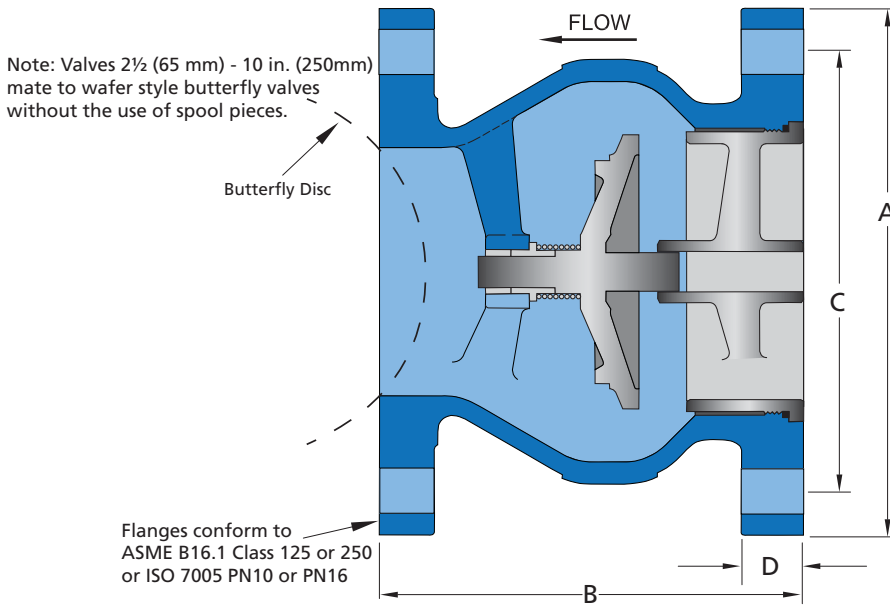

Dimensions - Inch							
Valve Size	CWP (psig)	ANSI Class	A	B	C	D	Weight (lb)
2 1/2	200	125	7.00	5.50	5.50	0.69	19
	400	250	7.50	5.50	5.88	1.00	30
3	200	125	7.50	6.00	6.00	0.94	28
	400	250	8.25	6.00	6.63	1.13	36
4	200	125	9.00	7.25	7.50	0.94	43
	400	250	10.00	7.25	7.88	1.25	59
5	200	125	10.00	8.50	8.50	0.94	55
	400	250	11.00	8.50	9.75	1.38	78
6	200	125	11.00	9.75	9.50	1.00	78
	400	250	12.50	9.75	10.63	1.44	103
8	200	125	13.50	12.50	11.75	1.13	102
	400	250	15.00	12.50	13.00	1.63	179
10	200	125	16.00	15.50	14.25	1.19	208
	400	250	17.50	15.50	15.25	1.88	253
12	200	125	19.00	14.25	17.00	1.25	294
	400	250	20.50	14.25	17.75	2.00	401
14	150	125	21.00	15.75	18.75	1.38	380
	300	250	23.00	15.75	20.25	2.13	511
16	150	125	23.50	17.63	21.25	1.44	501
	300	250	25.50	17.63	22.50	2.25	697
18	150	125	25.00	18.75	22.75	1.56	724
	300	250	28.00	18.75	24.75	2.38	959
20	150	125	27.50	20.63	25.00	1.69	890
	300	250	30.50	20.63	27.00	2.50	1,180
24	150	125	32.00	24.00	29.50	1.88	1,220
	300	250	36.00	24.00	32.00	2.75	1,680
30	150	125	38.75	29.25	36.00	2.13	2,100
	300	250	43.00	29.25	39.25	3.00	2,700
36	150	125	46.00	45.00	42.75	2.38	4,400
	300	250	50.00	46.00	46.00	3.38	5,100
42	150	125	53.00	50.00	49.50	2.63	7,200
	300	250	57.00	50.00	52.75	3.69	7,900

Dimensions - Metric							
Valve Size	CWP (Bar)	PN Class	A	B	C	D	Weight (kg)
65	16	10/16	178	140	145	18	9
	80	16	10/16	192	152	160	24
100	16	10/16	220	184	180	24	20
	125	16	10/16	250	216	210	24
150	16	10/16	285	248	240	25	35
	200	16	10	340	318	295	29
250		16	16	340	318	295	29
	300	16	10	395	362	350	30
350		16	16	405	362	355	30
	400	16	10	445	394	400	32
450		16	16	460	394	410	32
	500	10	10	505	400	460	35
550		16	16	520	400	470	35
	600	10	10	565	448	515	37
650		16	16	580	448	525	37
	700	10	10	615	476	565	40
750		16	16	640	476	585	40
	800	10	10	670	524	620	43
850		16	16	715	524	650	43
	900	10	10	780	610	725	48
950		16	16	840	610	770	48

PRESSURE RATINGS

MAXIMUM PRESSURE RATINGS				
SERIES	DESCRIPTION	SIZE RANGE	END CONNECTION	CWP psig (Bar)
1400THR	Threaded	1/2" - 2" (15-50mm)	Threaded NPT	250 (17.2)
1400A	Wafer Style	2" - 6" (50-150mm)	Wafer Class 125/250	400 (27.6)
		8" - 10" (200-250mm)	Wafer Class 125	200 (13.8)
		8" - 10" (200-250mm)	Wafer Class 250	400 (27.6)
1400A.4	Wafer Style Stainless Steel	2" - 10" (50-250mm)	Wafer Class 150	275 (19)
1800A	Globe Style	2 1/2" - 12" (65-250mm)	Flanged Class 125	200 (13.8)
		2 1/2" - 12" (65-250mm)	Flanged Class 250	400 (27.6)
1800A.4	Globe Style Stainless Steel	2 1/2" - 12" (65-250mm)	Flanged Class 150	275 (19)
1800	Globe Style	14" - 42" (300-1050mm)	Flanged Class 125	150 (10.3)
		14" - 42" (300-1050mm)	Flanged Class 250	300 (20.7)

MATERIALS OF CONSTRUCTION

Threaded Style

COMPONENT	STANDARD
Body	Lead-Free Bronze ASTM B584 C87600
Disc	Lead-Free Bronze ASTM B584 C87600
Seat	PTFE
Spring	T316 Stainless Steel

Wafer & Globe Style

COMPONENT	STANDARD	OPTIONAL
Body	Cast Iron ASTM A126, Class B	Stainless Steel A351 Grade CF8M Ductile Iron A536 Grade 65-45-12
Disc	Lead-Free Bronze ASTM B584 C87600	Stainless Steel A351 Grade CF8M
Seat	Lead-Free Bronze ASTM B584 C87600	Stainless Steel A351 Grade CF8M
Resilient Seat	-	Buna-N EPDM
Spring	T316 Stainless Steel	Severe Duty T316 Stainless Steel

Headloss Chart

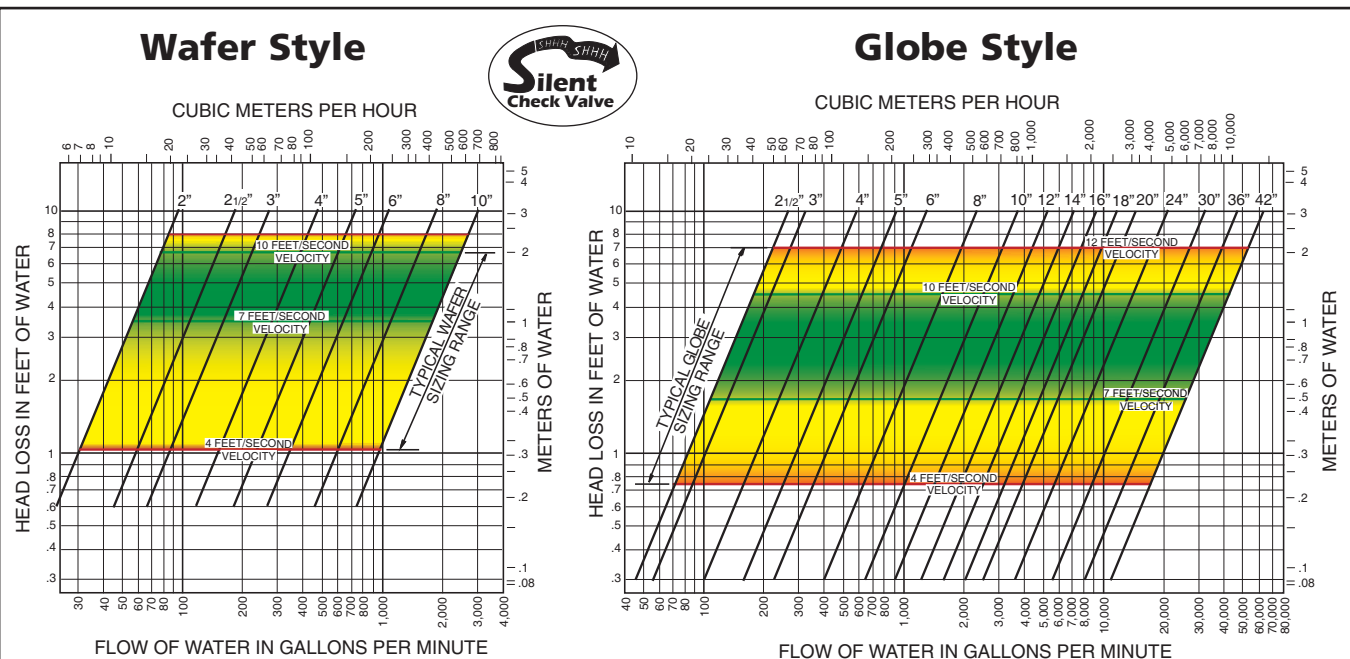

Flow Coefficients

Size	2	2 1/2	3	4	5	6	8	10	12	14	16	18	20	24	30	36	42
Wafer Cv	43	88	130	228	350	520	900	1450	-	-	-	-	-	-	-	-	-
Globe Cv	-	127	155	278	435	625	1115	1770	2500	3400	4400	5600	6900	10,000	15,400	22,400	30,400

SCOPE

- 1.1 This specification covers the design, manufacture, and testing of 1/2 in. (15 mm) through 2 in. (50 mm) Bronze Threaded Silent Check Valves, 2 in. (50 mm) through 10 in. (250 mm) Wafer Silent Check Valves and 2 1/2 in. (65 mm) through 42 in. (1050 mm) Globe Silent Check Valves suitable for pressures up to 500 psig (3450 kPa) water service.
- 1.2 The Check Valve shall be of the silent operating type that begins to close as the forward flow diminishes and fully closes at zero velocity preventing flow reversal and resultant water hammer. The dynamic characteristics of the valve shall be published and verified by independent laboratory test data.

STANDARDS AND APPROVALS

- 2.1 The valves for use in fire protection systems shall be Factory Mutual approved in Wafer Style sizes 2 in.- 6 in. Class 125/250, 8 in.- 10 in. Class 125 and Globe Style 2 1/2 in.- 10 in. Class 125/250, 12 in. Class 125.
- 2.2 Stainless steel valves shall meet the requirements of ASME B16.34 and MSS SP-126.
- 2.3 Wafer and Globe valves used in potable water service shall be certified to NSF/ANSI 61, Drinking Water System Components – Health Effects, and all valves shall be certified Lead-Free in accordance with NSF/ANSI 372.
- 2.4 Manufacturer shall have a quality management system that is certified to ISO 9001 by an accredited, certifying body.

CONNECTIONS

- 3.1 Threaded Style valves shall be provided in sizes 1/2 in. (15mm) through 2 in. (50mm) and have a two-piece body with female threaded NPT ends.
- 3.2 Globe style valves shall be provided in sizes 2 1/2 in. (65 mm) through 42 in. (1050 mm) and have flat faced flanges in accordance with ASME B16.1 for Class 125 or Class 250 iron flanges or in sizes 65 mm to 600 mm in accordance with ISO 7005 PN10 or PN16. Sizes 10 in. (250 mm) and smaller flanged valves shall be capable of mating directly to a wafer butterfly valve without disc interference. Stainless steel globe style valves shall include raised faces for installation between ASME B16.5 Class 150 flanges.
- 3.3 Wafer style valves shall be provided in sizes 2 in. (50 mm) through 10 in. (250 mm) for installation between ASME B16.1 Class 125 or Class 250 iron flanges or sizes 50 mm to 100 mm in accordance with ISO 7005 PN10 or PN16. Stainless steel wafer style valves shall include raised faces for installation between ASME B16.5 Class 150 flanges.

DESIGN

- 4.1 The valve design shall incorporate a center guided, spring loaded disc and have a short linear stroke that generates a flow area equal to the nominal valve size.
- 4.2 The operation of the valve shall not be affected by the position of installation. The valve shall be capable of operating in the horizontal or vertical positions with the flow up or down. Severe duty springs for vertical flow down installations shall be provided when specified on 14 in. and larger valves.

- 4.3 All component parts shall be field replaceable without the need of special tools. Wafer and Globe styles shall be provided with a replaceable guide bushing held in position by the spring. The spring shall be designed to withstand 100,000 cycles without failure and provide a cracking pressure of 0.5 psi for vertical installation.
- 4.4 The wafer and globe disc shall be concave to the flow direction providing for disc stabilization, maximum strength, and a minimum flow velocity to open the valve.
- 4.5 The valve disc and seat shall have a seating surface finish of 16 micro-inch or better to ensure positive seating at all pressures. The leakage rate shall not exceed the allowable rate for metal seated valves allowed by AWWA C508 and MSS SP-125 or 1 fl oz (30 ml) per hour per inch of nominal size.
- 4.6 Wafer and Globe style valve seats through 12 in. shall be fully retained to withstand full rated pressure of the valve without the seat mating flange. Globe style valve seats 14 in. and larger shall be contained with a machined counterbore and restrained by the mating flange and gasket.

MATERIALS

- 5.1 The threaded valve body and disc shall be lead free ASTM B584 copper alloy C87600 lead-free bronze materials. The seat shall be TFE. The spring shall be Type 316 stainless steel.
- 5.2 Globe and wafer valve bodies shall be constructed of ASTM A126 Class B cast iron for Class 125 and Class 250 valves and ASTM A351 Grade CF8M for Class 150 stainless steel valves. Optional body material includes ASTM A536 Grade 65-45-12 ductile iron.
- 5.3 Globe and wafer seat and disc shall be ASTM B584 Alloy C87600 cast bronze. Optional trim material includes ASTM A351 Grade CF8M stainless steel.
- 5.4 Globe and wafer compression spring shall be ASTM A313 Type 316 stainless steel with ground ends.

OPTIONS

- 6.1 A resilient seal shall be provided on the seat when specified to provide zero leakage at both high and low pressures without overloading or damaging the seal. The seal design shall provide both a metal-to-metal and a metal-to-resilient seal.
- 6.2 Valve interiors and exteriors shall be coated with an NSF/ANSI 61 certified fusion bonded epoxy in accordance with AWWA C550 when specified.

MANUFACTURE

- 7.1 The valves shall be hydrostatically tested at a minimum 1.5 times their rated cold working pressure and seat tested at the valve CWP. When requested, the manufacturer shall provide test certificates, dimensional drawings, parts list drawings, and operation and maintenance manuals.
- 7.2 The exterior of the valve shall be coated with a universal alkyd primer.
- 7.3 Silent Check Valves shall be Series #1400THR.1 (Threaded Style), Series #1400A (Wafer Style) or 1800A or 1800 (Globe Style) as manufactured by Val-Matic® Valve & Mfg. Corporation, Elmhurst, IL. USA or approved equal.



Silent Check Valve on a Test Stand

VAL-MATIC®



AWWA Swing Check Valves



NSF/ANSI 61 & 372 Certified

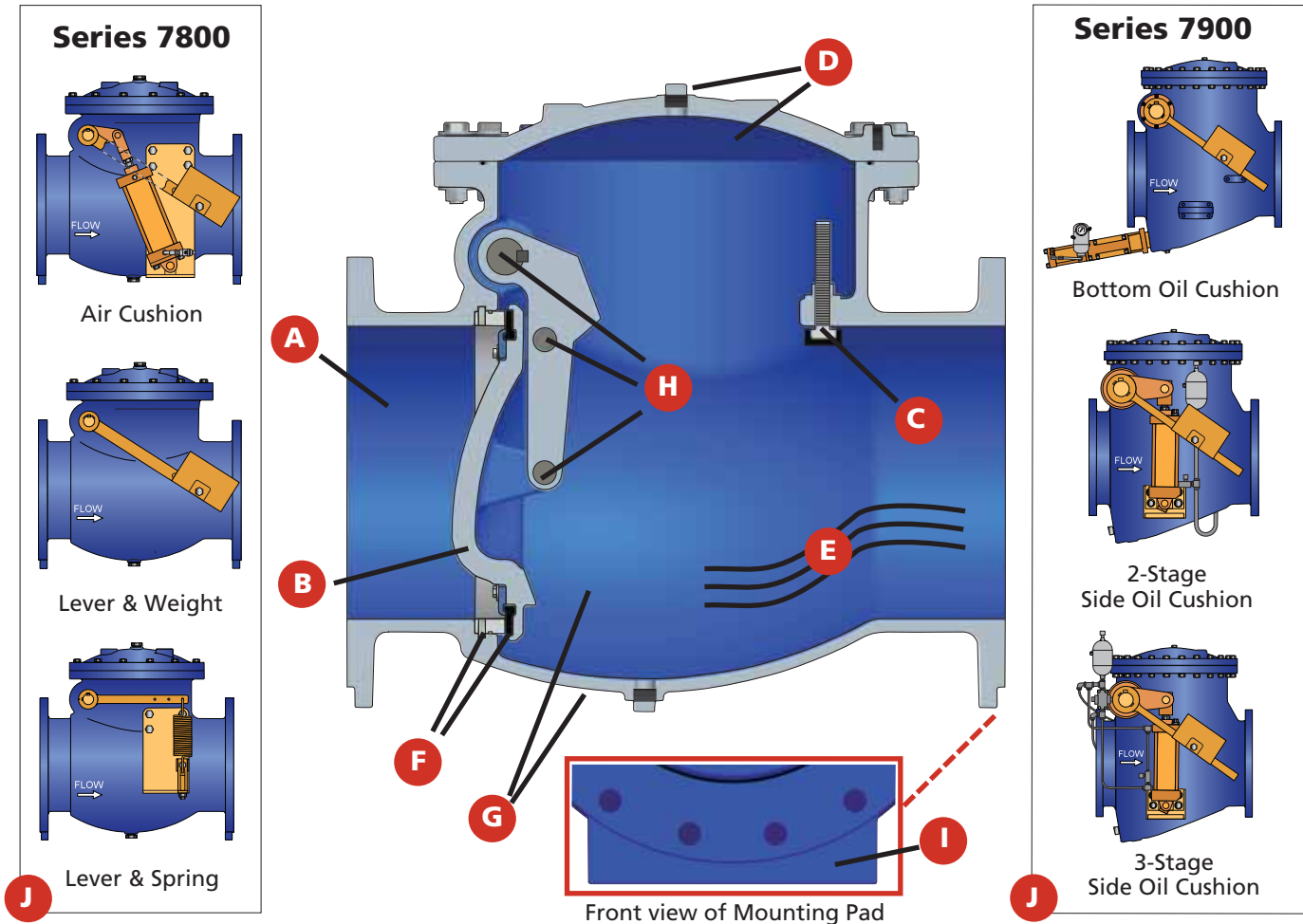

A. 100% Flow Area
Energy savings provided with 100% unrestricted flow area.

B. Disc Stabilization
The fluid dynamic convex disc provides for lift, stabilization and strength.

C. Adjustable Stop
Adjustable resilient open stop to prevent disc flutter for applications outside the typical flow ranges.

D. Full Domed Access Cover with Vent Port
Full domed access cover allows for ease of maintenance without removing the valve from the line. The vent port allows the addition of an air release valve or pressure gauge.

E. Non-Clog Design
The unrestricted full flow area combined with smooth streamline

contouring allows for passage of large solids to prevent potential clogging.

F. Seating Options
The field replaceable synthetic seat, with integral O-ring, assures positive seating at high and low pressures. Body seats are stainless steel to extend the life of the valve and are also field replaceable.

When operating conditions require a metal-to-metal seat, the disc is fitted with a precision machined aluminum bronze seating surface. The disc seat seals against the field replaceable aluminum bronze body seat for reliable operation under harsh conditions.

G. Fusion Bonded Epoxy
Fusion Bonded Epoxy (FBE) is provided standard on the interior and exterior of the valve. The FBE is NSF/ANSI 61 certified and complies with AWWA C550.

H. Heavy Duty Disc Connections
Heavy duty shaft and disc retaining pins constructed of high tensile stainless steel for superior strength, wear resistance and extended life.

I. Mounting Pads
Integral mounting pads provide vertical support for ease of installation. The pads are integral to both flanges and are standard on Series 7800 valves. When necessary for installation, mounting pads can be provided on Series 7900 valves.

J. Closure Versatility
The Series 7800 AWWA Swing Check Valve is available with multiple field adjustable closure options: Air Cushion, Lever & Weight and Lever & Spring. The Series 7900 is available with either bottom or side oil cushions.

Proven Design

The Val-Matic Swing Check Valve incorporates many design features and characteristics that will provide energy savings, ease of maintenance and extended valve life. The valve is designed for municipal and industrial water and wastewater applications and fully complies with ANSI/AWWA C508 and MSS SP-71/ MSS SP-136.

Closure Versatility

7800 Air Cushion, Lever & Weight, Lever & Spring

The Series 7800 Swing Check Valves can be supplied with Air Cushion, Lever & Weight or Lever & Spring for control of the disc closure. The Lever & Weight or Lever & Spring designs are suitable for installation in horizontal or vertical pipelines and are easily adjustable in the field. When rapid flow reversal occurs, the Swing Check Valves can be supplied with dual lever arms, weights and springs. A fully enclosed and adjustable Air Cushion can be added to the standard Lever & Weight to control valve operation and reduce water hammer.

7900 Oil Cushion

The Series 7900 Swing Check Valves include single or dual lever arms with weights and are equipped with either side or bottom oil cushions. The bottom oil cushion provides adjustable control of the final 10% of disc closure. The side oil cushion allows for independent adjustment of closure speeds in either 2- or 3- stages.

Ductile Iron Construction

Val-Matic provides standard Swing Check Valves with ductile iron construction rated to 250 psig Cold Working Pressure (CWP). Ductile iron provides greater strength and toughness than conventional gray iron materials. With ductile iron construction, the body, disc, and disc arm can safely withstand high stresses and shock loads.

Seating System

Val-Matic Swing Check Valves are offered with either drop-tight resilient seating or aluminum bronze metal seating.

Resilient Seating System

For resilient seated valves, the body is fitted with a 300 series stainless steel seat that is raised from the body to assure sealing in applications with high solids. A molded resilient seat mounted on the disc has integral O-ring sealing surfaces for drop tight sealing at high and low pressures. Both seats are secured with stainless steel fasteners and are field replaceable without removing the valve from the line. (See Figure 1)

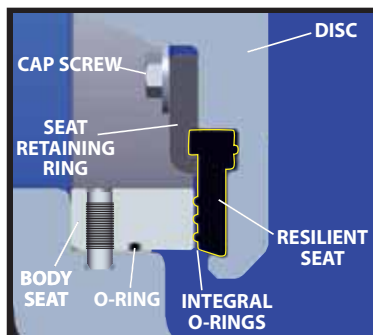

Figure 1 - Resilient Seating System

Metal Seating System

For metal seated valves, the body is fitted with an aluminum bronze seat secured to the body. The body seat mates with a second aluminum bronze seat integral with the disc. (See Figure 2)

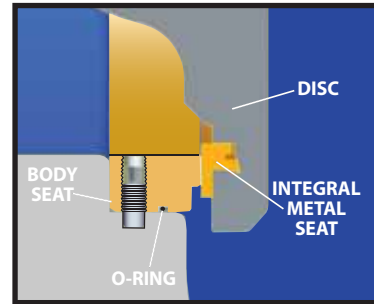

Figure 2 - Metal Seating System

Shaft Seal System

V-Type Packing

The Series 7800 Swing Check Valves are designed with an enhanced V-Type packing system to prevent overload of the packing, the most common reason for packing leakage and failure. To prevent the packing from being over tightened, the shaft seal incorporates POP™ (Packing Overload Protection) Shims with pull tabs. Adjustment is easily accomplished by removing shims as necessary utilizing the pull tab feature. (See Figure 3)

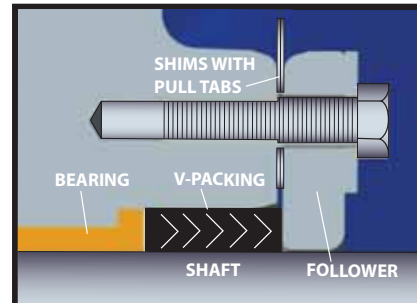

Figure 3 - Series 7800 Shaft Seal System V-Packing

O-ring Cartridge

The Series 7900 Swing Check Valves are designed with dual O-ring seals contained in a corrosion resistant cartridge to provide low torque during operation. (See Figure 4)

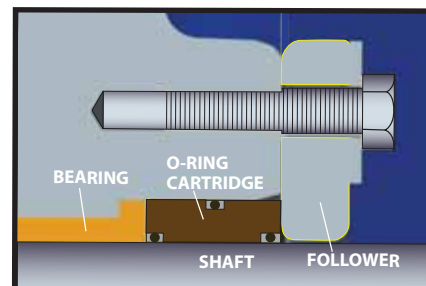

Figure 4 - Series 7900 Shaft Seal System O-ring Cartridge

Corrosion Resistance

The body and disc are fully encapsulated with NSF/ANSI 61 certified fusion bonded epoxy per AWWA C550 to prevent corrosion and provide extended service life. The shaft, disc pins, and seat hardware are constructed of stainless steel for maximum corrosion resistance even in severe service. Lead-Free Bronze bushings are provided in the body to provide smooth and reliable disc closure.

Swing Check Valves

Installation Dimensions

Series 7800AC
Air Cushion

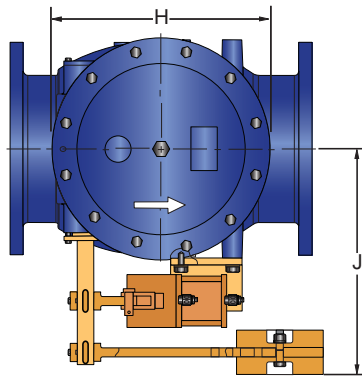

Series 7800LW
Lever & Weight

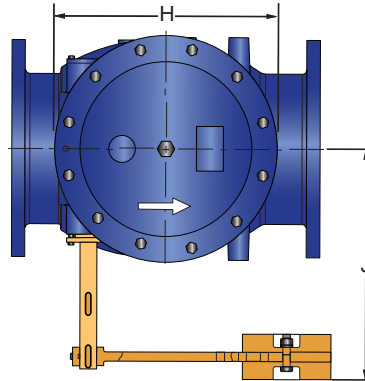

Series 7800LS
Lever & Spring

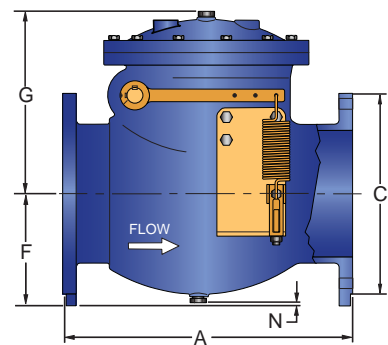
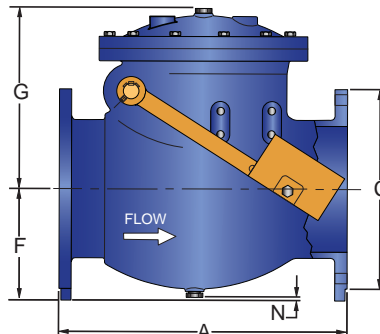
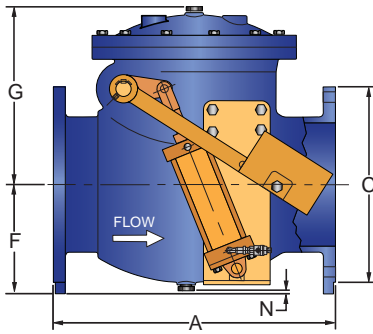
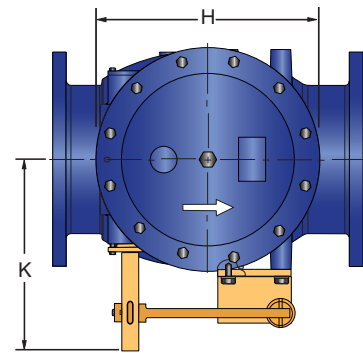

Flanges drilled to ASME B16.1 Class 125 and B16.42 Class 150

Dimensions in Inches

Valve Size	CWP (psig)	A	C	F	G	H	J	K	N*	AC Valve Weights (lbs)	LW Valve Weights (lbs)	LS Valve Weights (lbs)
2	250	8.00	6.00	3.00	4.34	5.39	5.25	4.21	0.27	-	28	26
2 1/2	250	8.50	7.00	3.50	4.34	5.78	7.00	6.77	0.62	-	37	34
3	250	9.50	7.50	4.17	6.69	7.01	7.38	6.97	0.46	65	55	51
4	250	11.50	9.00	4.92	7.60	7.87	8.63	8.23	0.43	105	90	79
6	250	14.00	11.00	6.69	10.53	12.60	12.50	12.22	0.59	205	185	169
8	250	19.50	13.50	8.46	12.80	15.75	15.75	15.16	0.97	351	326	286
10	250	24.50	16.00	8.66	14.33	17.52	17.38	16.61	-0.13	519	484	440
12	250	27.50	19.00	10.63	17.32	19.88	17.88	17.32	0.30	763	723	669
14	250	31.00	21.00	12.50	19.96	23.88	23.13	22.63	-0.04	1061	1011	958
16	250	36.00	23.50	13.75	21.22	26.50	25.00	24.25	-1.29	1227	1177	1101
18	250	40.00	25.00	15.00	23.22	27.88	26.38	25.63	-0.16	1571	1521	1431
20	250	40.00	27.50	16.00	24.94	30.44	28.25	27.50	-0.66	1940	1890	1764
24	250	48.00	32.00	18.50	30.34	36.63	32.75	32.13	0.90	3112	3052	2837
30	150	60.00	38.75	22.00	38.47	43.81	40.75	39.81	-0.87	6148	6088	5708
	250											
36	150	63.00	46.00	25.50	43.22	51.41	45.06	43.81	-1.89	8555	8495	8037
	250											
42	150	70.00	53.00	29.25	49.80	59.88	50.00	48.50	-2.38	11460	11380	10680
	250											
48	150	76.00	59.50	32.75	56.38	68.38	55.13	53.00	-2.63	16860	16780	15940
	250											

*Dimension "N" with negative numbers extend past bottom of integral mounting pads (flange feet).

Series 7900B
Bottom Oil Cushion

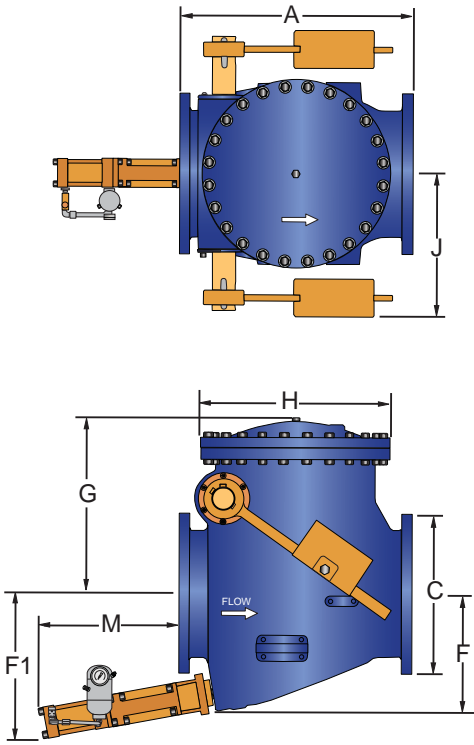

Series 7900S2
2-Stage
Side Oil Cushion

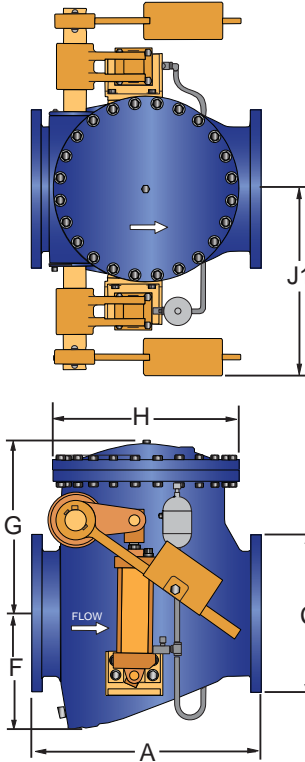

Series 7900S3
3-Stage
Side Oil Cushion

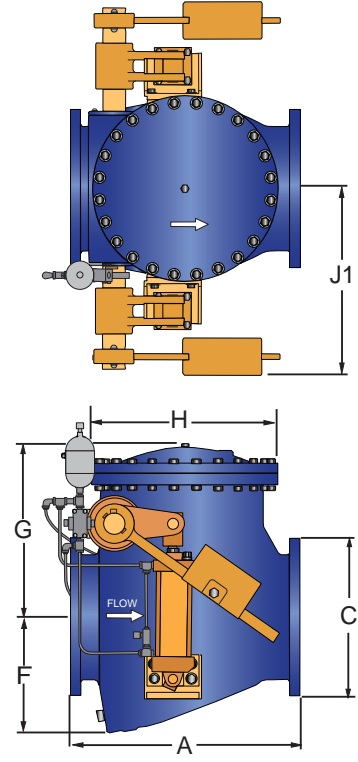

Flanges drilled to ASME B16.42 Class 150

Dimensions in Inches												
Valve Size*	CWP (psig)	A	C	F	F1	G	H	J Typ.	J1 Typ.	M	Bottom Valve Weights (lbs)	Side Valve Weights (lbs)
8	200	19.50	13.50	11.25	12.75	15.50	16.50	13.25	18.00	13.50	450	650
10	200	24.50	16.00	13.38	15.13	17.75	19.75	14.25	20.00	15.00	675	980
12	200	27.50	19.00	14.56	16.44	20.16	22.63	16.13	22.00	14.13	960	1400
14	150	31.00	21.00	17.00	20.00	22.25	25.38	19.50	26.57	18.50	1064	1780
16	150	36.00	23.50	18.50	21.25	25.69	28.31	21.75	28.75	17.00	1253	2450
18	150	40.00	25.00	19.00	23.06	28.00	30.88	23.13	31.13	20.63	1521	3130
20	150	40.00	27.50	20.50	24.25	30.25	32.50	24.63	32.63	21.50	1890	3625
24	150	48.00	32.00	24.88	28.50	36.25	38.75	29.50	39.50	24.38	3052	6100
30	150	60.00	38.75	29.50	34.06	38.50	43.81	32.00	-	26.56	5514	-
36	150	63.00	46.00	32.25	38.00	43.25	51.40	36.50	-	35.00	8151	-
42	150	70.00	53.00	35.13	41.25	43.75	60.00	39.00	-	41.25	11380	-
48	150	76.00	59.50	39.00	45.81	56.38	68.38	44.00	-	47.50	16780	-

*Valve Sizes 8"-12" only have a single lever and weight.

Principle of Operation

Oil Cushion Valves

The Series 7900 Oil Cushion Swing Check Valves are ideal in any number of installation configurations including single or multiple pump systems to reduce slamming and reduce system pressure surges. The Series 7900 Check Valve is offered with optional bottom or side oil cushions to aid in disc closure in pump systems even after a power failure. The oil cushions include high pressure hydraulic oil cylinders, flow control valves, and full-rated disc connections. With oil cushions, the movement of the disc is precisely controlled. An adjustable flow control valve regulates the flow of hydraulic oil out of the cylinder, which in-turn controls movement of the disc closure.

Series 7900B Bottom Oil Cushion

In high pressure applications where rapid flow reversals are expected, the last 10% of closure can be controlled to prevent slamming by using a Bottom Oil Cushion consisting of a hydraulic cylinder and snubber rod that contacts the valve disc near the end of travel. When there is flow through the valve, the valve disc lifts off of the snubber rod and opens normally as the flow rate increases. When the valve is open, the air pressure in the accumulator extends the cylinder which pushes the snubber rod into the valve body. When flow stops, the disc closes rapidly through 90% of its travel and then strikes the snubber rod. The last 10% of closure is then controlled in 1-3 seconds by the hydraulic cylinder as the oil flow is metered through the adjustable flow control valve.

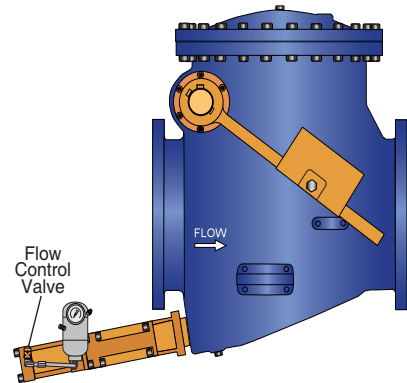

Series 7900S2 2-Stage Side Oil Cushion

When control of the full valve closure is desired to reduce system surges, a 2-Stage Oil Cushion can be used consisting of a high pressure hydraulic cylinder and lever that is directly attached to the shaft. When there is flow through the valve, the valve opens normally while the shaft lever extends the cylinder. When flow stops, the lever contracts the cylinder and the speed of closure is controlled in 5-30 seconds by the oil flow through the adjustable flow control valve for Stage 1. During the last 10% of travel, the closure is controlled in 1-3 seconds using the internal cylinder cushion adjustment for Stage 2.

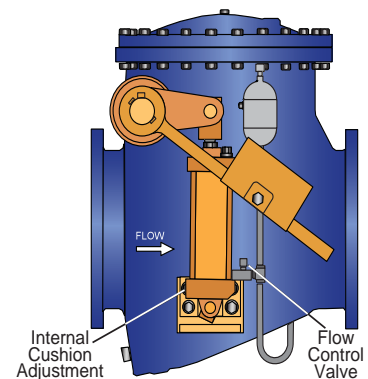

Series 7900S3 3-Stage Side Oil Cushion

For long pipelines, when control of full valve travel is desired in multiple stages, a 3-Stage Oil Cushion can be used to control the closing speed of the Check Valve at three rates. The 3-Stage Oil Cushion consists of a high pressure hydraulic cylinder, a lever that is directly attached to the shaft, and a cam-operated 2-way directional valve that is used to direct flow to a flow control valve. When there is a flow through the Check Valve, the valve opens normally while the hinge pin lever extends the cylinder. When flow stops, the Check Valve closes rapidly while the lever contracts the cylinder for Stage 1. When the valve travels to the 50% position (adjustable), the 2-way valve closes, and the oil flow from the cylinder is directed through the adjustable flow control valve in 5-30 seconds for Stage 2. During the last 10% of travel, the closure is controlled in 1-3 seconds using the internal cylinder cushion adjustment for Stage 3.

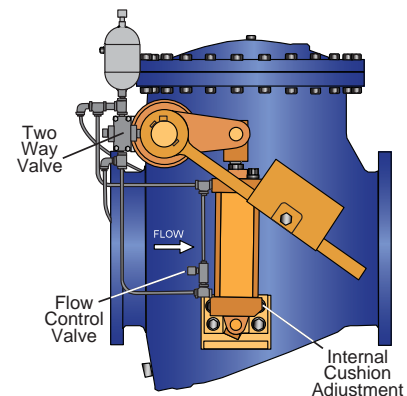

A variety of closure mechanisms allows selection of the correct Swing Check Valve for every application. This application chart illustrates the range of use for the various Swing Check configurations.

Pumping systems with low static head and gradual pipeline flow deceleration may be best served by a conventional lever & weight or air cushion Swing Check. Higher static head applications benefit from a rapid spring assisted closure. When severe deceleration is present in a pumping system, oil cushioned closure provides an economical and reliable means of preventing surges associated with transients while greatly minimizing the potential for check valve slam. The adjustability of closure times on oil cushion Swing Check Valves allows operation to be tailored for each application.

RECOMMENDED VALVE SELECTION

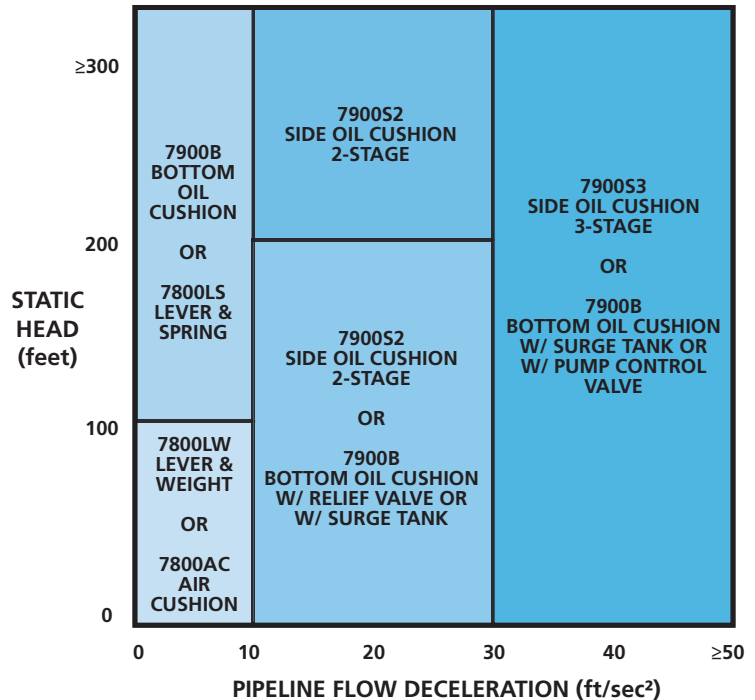

Headloss Chart

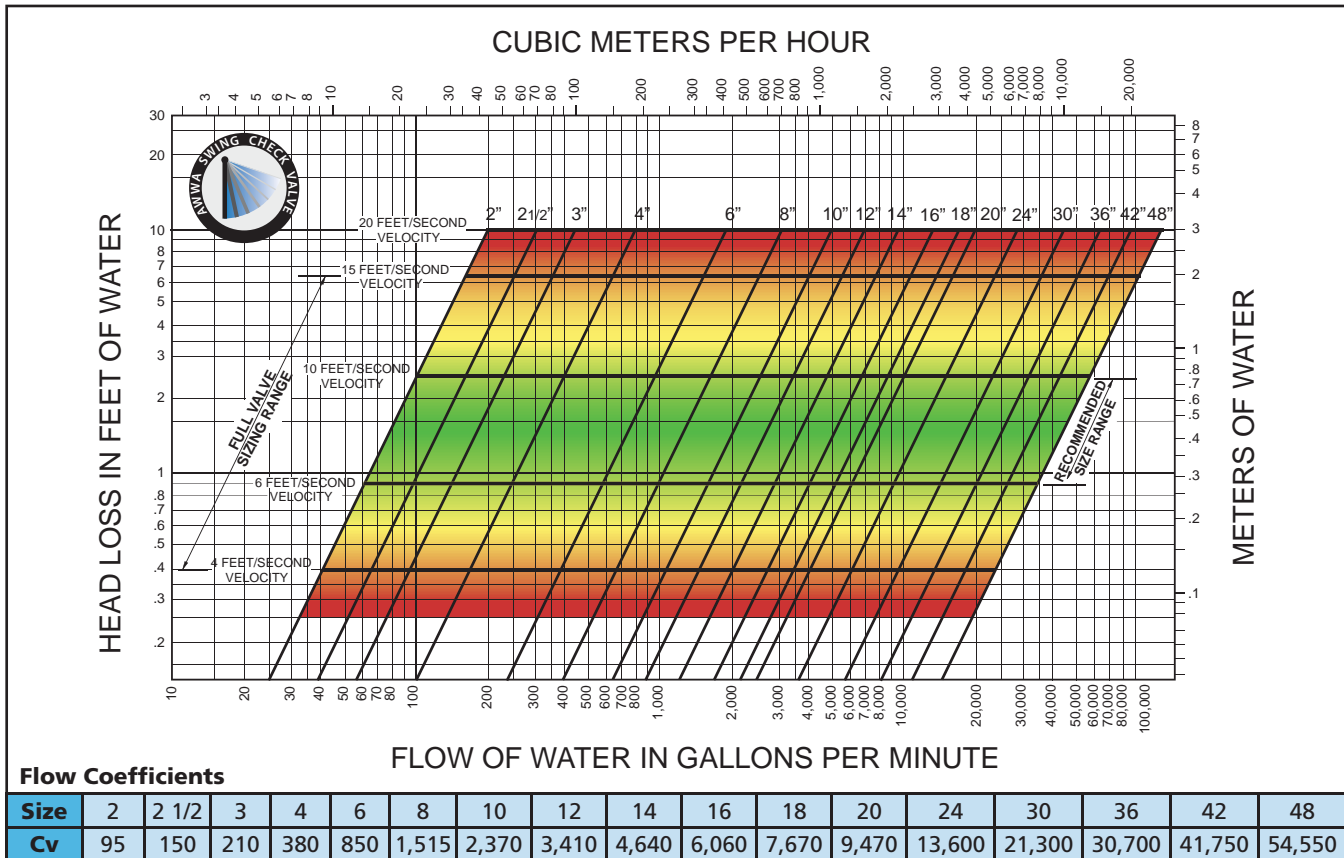

Swing Check Valves

Swing Check Valves

Pressure Ratings

MAXIMUM PRESSURE RATINGS				
SERIES	DESCRIPTION	SIZE RANGE	FLANGE CONNECTION	CWP (psig)
7800AC	Air Cushion	3" - 48"	Class 150 Ductile Iron	250
7800LW	Lever & Weight	2" - 48"		
7800LS	Lever & Spring	2" - 48"		

MAXIMUM PRESSURE RATINGS				
SERIES	DESCRIPTION	SIZE RANGE	FLANGE CONNECTION	CWP (psig)
7900B	Lever & Weight Bottom Oil Cushion	8" - 12"	Class 150 Ductile Iron	200
		14" - 48"		150
7900S	Lever & Weight Side Oil Cushion	8" - 12"	Class 150 Ductile Iron	200
		14" - 24"		150

Materials of Construction

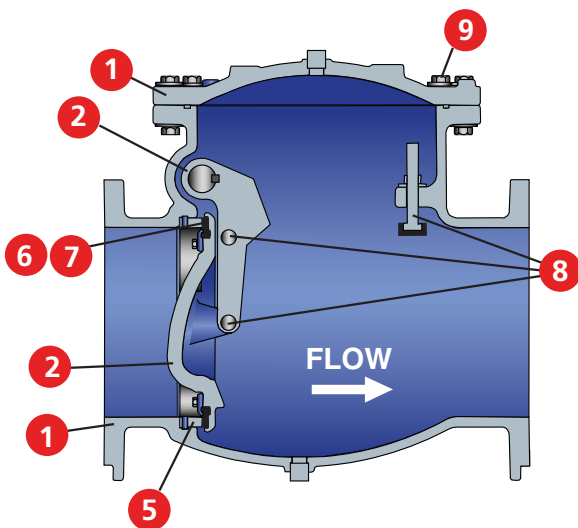
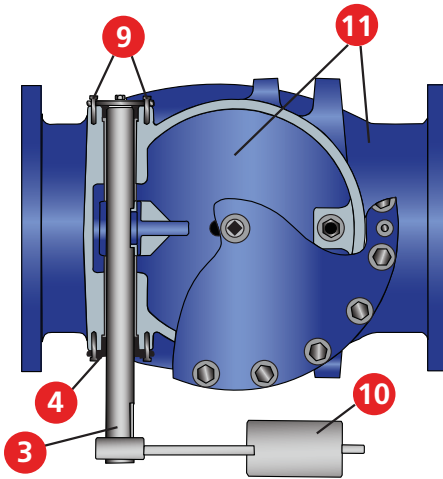

ASSY NO.	COMPONENT	STANDARD	OPTIONAL
1	7800 Body and Cover 2" - 48"	Ductile Iron ASTM A536 Gr 65-45-12	N/A
	7900 Body and Cover 8" - 48"	Ductile Iron ASTM A536 Gr 65-45-12	N/A
2	Disc and Arm	Ductile Iron ASTM A536 Gr 65-45-12	N/A
3	7800 Shaft	T304 Stainless Steel	N/A
	7900 Shaft	T630 Stainless Steel	N/A
4	7800 Shaft Seal	V-Packing Buna-N	N/A
	7900 Shaft Seal	O-ring Buna-N	N/A
5	Removable Body Seat	Stainless Steel ASTM A276 Type 304 or Aluminum Bronze C95400	N/A
6	Molded Resilient Seat	Buna-N	EPDM
7	Metal Integral Seat	Aluminum Bronze C95400	N/A
8	7800 Internal Hardware	T304 Stainless Steel	T316 Stainless Steel
	7900 Internal Hardware	T630 Stainless Steel	T316 Stainless Steel
9	External Hardware 2" - 12"	T304 Stainless Steel	T316 Stainless Steel
	External Hardware 14" - 48"	Alloy Steel, Plated	T316 Stainless Steel
10	External Lever(s)	Ductile Iron ASTM A536 Gr 65-45-12	N/A
11	Internal/External Coating System	Fusion Bonded Epoxy NSF/ANSI 61	N/A

Limit Switch

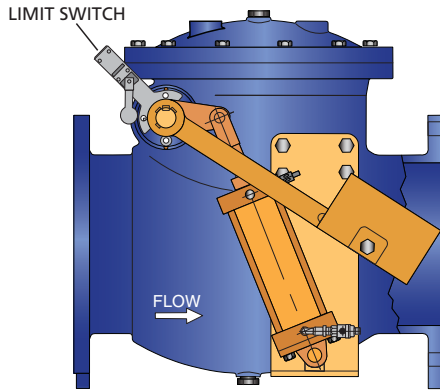

Limit Switch available to indicate open and/or closed valve position for offsite monitoring.

Air Valve Vent & Drain Valve

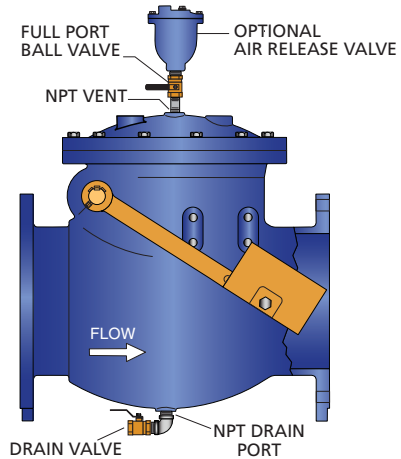

An air release valve prevents the collection of air in the valve and downstream piping to prevent water hammer and system flow restrictions. The drain facilitates maintenance and the removal of silt.

Reverse Mount

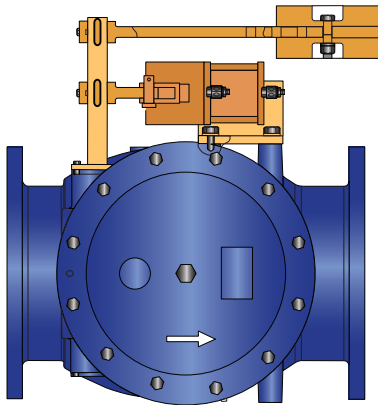

Reverse mount is used to accommodate specific field conditions.

Vertical Installation

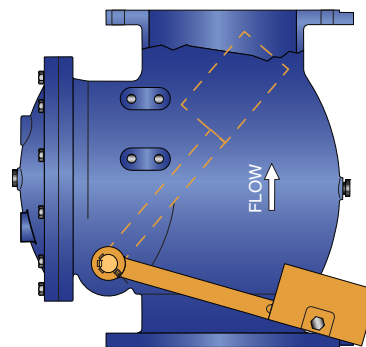

Vertical installation can accommodate specific field conditions and flow up applications.

Safety Guard

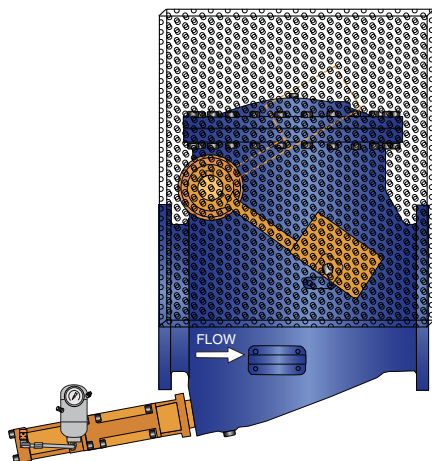

The Safety Guard meets OSHA requirements and can be supplied for all lever weight and cushion assemblies.

Dual Weights

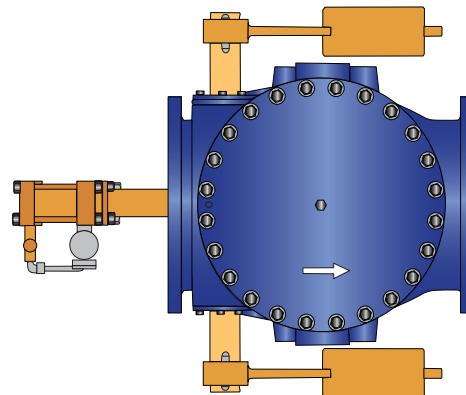

Dual weights are available to provide rapid closure.

SCOPE

- 1.1 This specification covers the design, manufacture, and testing of 2 in. (50 mm) through 48 in. (1200 mm) Swing Check Valves suitable for cold working pressures of 250 psig.
- 1.2 The check valve shall be of the full flow body type, with a domed access cover and vent port.
- 1.3 The check valve shall be capable of accepting air cushion, lever and weight or lever and spring.

STANDARDS AND APPROVALS

- 2.1 The valves shall be designed, manufactured and tested in accordance with American Water Works Association Standard ANSI/AWWA C508 and in accordance with Manufacturers Standardization Society Standard Practice MSS SP-71 or MSS SP-136.
- 2.2 The valves used in potable water service shall be certified to NSF/ANSI 61, Drinking Water System Components – Health Effects, and certified to be Lead-Free in accordance with NSF/ANSI 372.
- 2.3 Manufacturer shall have a quality management system that is certified to ISO 9001 by an accredited, certifying body.

CONNECTIONS

- 3.1 The Valves shall be provided with flanges drilled in accordance with ASME B16.1, Class 125 iron flanges or ASME B16.42, Class 150 for ductile iron flanges.

DESIGN

- 4.1 The valve body shall be full flow equal to nominal pipe diameter at all points through the valve and shall be equipped with a threaded adjustable open stop. The body seat shall be O-ring sealed and field replaceable without removing the valve from the line. The end flanges shall contain integrally cast mounting pads.
- 4.2 The top access port shall be full size, allowing removal of the disc without removing the valve from the line. The access cover shall be domed in shape to provide flushing action over the disc for operating in lines containing high solids content.
- 4.3 The disc shall be of one-piece construction and connected to the shaft with a disc arm and two pivot pins to provide pivot action to allow self-adjusting seating at all pressures. 14" and larger discs shall be convex shape for lift, stabilization and strength.
- 4.4 When specified, the disc seat shall be resilient with integral O-ring type sealing surface for drop tight shut-off at high and low pressures and for easy replacement in the field without removing the valve from the line.
- 4.5 When specified, metal seated valves shall have aluminum bronze seats.
- 4.6 The shaft seals shall consist of V-type packing in a fixed gland with an adjustable follower designed to prevent over compression of the packing and to meet design parameters of the packing manufacturer. Removable, slotted shims shall be provided under the follower flanges to provide for adjustment and prevent over loading of the packing.

- 4.7 When specified, the valve shall be factory equipped with a lever and weight assembly. The lever shall be equipped with three holes for adjusting the bolted weight assembly. When the valve is closed, the lever and weight shall be located 30 degrees below horizontal.
- 4.8 When specified, the valve shall be factory equipped with a lever and air cushion assembly mounted between the weight assembly and the valve body. The air cushion assembly shall consist of a clevis mounted tie-rod type closed cylinder with speed control valves.
- 4.9 When specified, the valve shall be factory equipped with a lever and spring assembly. The spring shall be mounted to a bracket on the side of the valve body with a bolt assembly to adjust the spring tension.

MATERIALS

- 5.1 The valve body, cover and disc shall be constructed of ASTM A536 Grade 65-45-12 ductile iron.
- 5.2 The exterior and interior of the valve shall be coated with an NSF/ANSI 61 approved fusion bonded epoxy coating.
- 5.3 The removable body seat shall be constructed of ASTM A276, Type 304 stainless steel.
- 5.4 The removable resilient seat shall be precision molded Buna-N (NBR), ASTM D2000-BG. When specified, optional seat material includes EPDM.
- 5.5 The disc, arm, and external levers shall be ductile iron.

OPTIONS

- 6.1 A pre-wired limit switch shall be provided (when specified) to indicate open/closed position to a remote location. The mechanical type limit switch shall be activated by the external arm and rated for NEMA 4, 6, or 6P and shall have U.L. rated 5 amp, 125 or 250 VAC contacts.
- 6.2 When specified, the lever and weight assembly shall be enclosed within a removable safety guard constructed of perforated metal for visibility.

MANUFACTURE

- 7.1 Manufacturer shall demonstrate a minimum of five (5) years' experience in the manufacture of swing check valves.
- 7.2 All valves shall be hydrostatically and seat tested per AWWA C508 to demonstrate leakage criteria and structural integrity. When requested, the manufacturer shall provide test certificates, dimensional drawings, parts list drawings, and operation and maintenance manuals.
- 7.3 Swing Check Valves shall be Series 7800 (resilient seated) or 7800M (metal seated) and equipped with AC (air cushion), LW (lever and weight), or LS (lever and spring) as manufactured by Val-Matic® Valve & Mfg. Corporation, Elmhurst, IL USA or approved equal.

SCOPE

- 1.1 This specification covers the design, manufacture, and testing of 8 in. (200 mm) through 48 in. (1200 mm) Swing Check Valves suitable for water and wastewater service.
- 1.2 The Cold Working Pressure rating of the valves shall be 200 psig for 8 in. (200 mm) to 12 in. (300 mm) sizes and 150 psig for 14 in. (350 mm) and larger.
- 1.3 The Swing Check Valve shall be of the full waterway body type, with a drain port and domed access cover with vent port.
- 1.4 A Bottom Oil Cushion with Lever and Weight shall be provided on sizes 8 in. (200 mm) to 48 in. (1200 mm) when specified.
- 1.5 A 2-Stage or 3-Stage Side Oil Cushion and Lever and Weight shall be provided on sizes 8 in. (200 mm) to 24 in. (600 mm) when specified.

STANDARDS AND APPROVALS

- 2.1 The valves shall be designed, manufactured and tested in accordance with American Water Works Association Standard ANSI/AWWA C508 and in accordance with Manufacturers Standardization Society Standard Practice MSS SP-136.
- 2.2 The valves used in potable water service shall be certified to NSF/ANSI 61, Drinking Water System Components - Health Effects, and certified to be Lead-Free in accordance with NSF/ANSI 372.
- 2.3 Manufacturer shall have a quality management system that is certified to ISO 9001 by an accredited, certifying body.

CONNECTIONS

- 3.1 The Valves shall be provided with flanges drilled in accordance with ASME B16.42, Class 150 for ductile iron flanges.

DESIGN

- 4.1 The valve body shall be full flow equal to nominal pipe diameter area at all points through the valve and shall be equipped with a threaded adjustable open stop. The body seat shall be O-ring sealed and field replaceable without removing the valve from the line.
- 4.2 The top access port shall be full size, allowing removal of the disc without removing the valve from the line. The access cover shall be domed in shape to provide flushing action over the disc for operating in lines containing high solids content.
- 4.3 The disc shall be of one-piece construction and connected to the shaft with a disc arm and two pivot pins to provide pivot action to allow self-adjusting seating at all pressures. Discs shall be convex shape for lift, stabilization and strength.
- 4.4 When side oil cushions are specified, the shaft and keys shall be sized to withstand the full differential pressure torque.
- 4.5 When specified, metal seated valves shall have aluminum bronze seats.
- 4.6 When specified, resilient seated valves shall have a disc seat of a resilient material with integral O-ring type sealing surface for drop tight shut-off at high and low pressures and for easy replacement in the field without removing the valve from the line.
- 4.7 The shaft seals shall be a replaceable lead free bronze O-ring cartridge type.
- 4.8 Valves shall be factory equipped with a lever and weight assembly. The lever shall be equipped with three holes for adjusting the bolted weight assembly. The 8 in. oil cushion valves shall have one weight and lever assembly; 14 in. and larger

valves shall be factory equipped with two lever and weight assemblies. When the valve is closed, the lever and weight shall be located 30 degrees below horizontal.

- 4.9 A bottom oil cushion shall be factory installed to provide hydraulic control of the final 10% of valve closure and reduce water hammer normally associated with rapid flow reversal conditions on pump shut down. The cushion shall consist of a high pressure hydraulic cylinder, adjustable external flow control valve, pressurized oil reservoir and piping designed to control the closing speed of the last 10% of travel in 1-5 seconds. A cushion spacer which connects the cylinder to the valve shall have an air gap to prevent hydraulic fluid from entering the valve and contaminating the water system. A snubber rod fitted with O-ring seals and rod wiper scrapers shall make contact with the lower portion of the disc during closure.
- 4.10 When specified on side oil cushion valves as 2-stage oil cushion, the control function is as follows: During closure, the oil cylinder controls the speed of closure. As the check valve closes, oil from the bottom port of the cylinder is controlled by the Flow Control valve, typically 5-30 seconds. During the last 10% of travel, the closure is controlled using the internal cushion adjustment, typically 1-3 seconds.
- 4.11 When specified on side oil cushion valves as 3-stage oil cushion, the control function is as follows: During closure, the oil cylinder controls the speed of closure in three stages. As the check valve closes, oil from the bottom port of the cylinder flows freely through the 2-way valve allowing the valve to close rapidly, typically 1 to 2 seconds. When the valve travels to the 50% closed position (adjustable), the 2-way valve closes. The oil now is controlled by the Flow Control Valve, typically 5-30 seconds. During the last 10% of travel, the closure is controlled using the internal cushion adjustment, typically 1-3 seconds.

MATERIALS

- 5.1 The valve body, cover and disc shall be constructed of ASTM A536 Grade 65-45-12 ductile iron.
- 5.2 The shaft shall be ASTM A276, T304 stainless steel for bottom oil cushion valves and ASTM A564 T630 H900 alloy stainless steel for side oil cushion valves.
- 5.3 The exterior and interior of the valve shall be coated with an NSF/ANSI 61 approved fusion bonded epoxy coating.
- 5.4 The removable body seat and integral metal disc seat shall be constructed of aluminum bronze C95400.
- 5.5 The optional resilient seated disc seat shall be precision molded Buna-N (NBR), ASTM D2000-BG. When specified, optional seat material includes EPDM.
- 5.6 The disc arm and external levers shall be ASTM A536 Grade 65-45-12 ductile iron.

MANUFACTURE

- 6.1 Manufacturer shall demonstrate a minimum of five (5) years' experience in the manufacture of swing check valves.
- 6.2 All valves shall be hydrostatically and seat tested per AWWA C508 to demonstrate zero leakage and structural integrity. When requested, the manufacturer shall provide test certificates, dimensional drawings, parts list drawings, and operation and maintenance manuals.
- 6.3 Swing Check Valves shall be Series 7900B and 7900S as manufactured by Val-Matic® Valve & Mfg. Corporation, Elmhurst, IL USA or approved equal.



Air Cushion Swing Check Valve

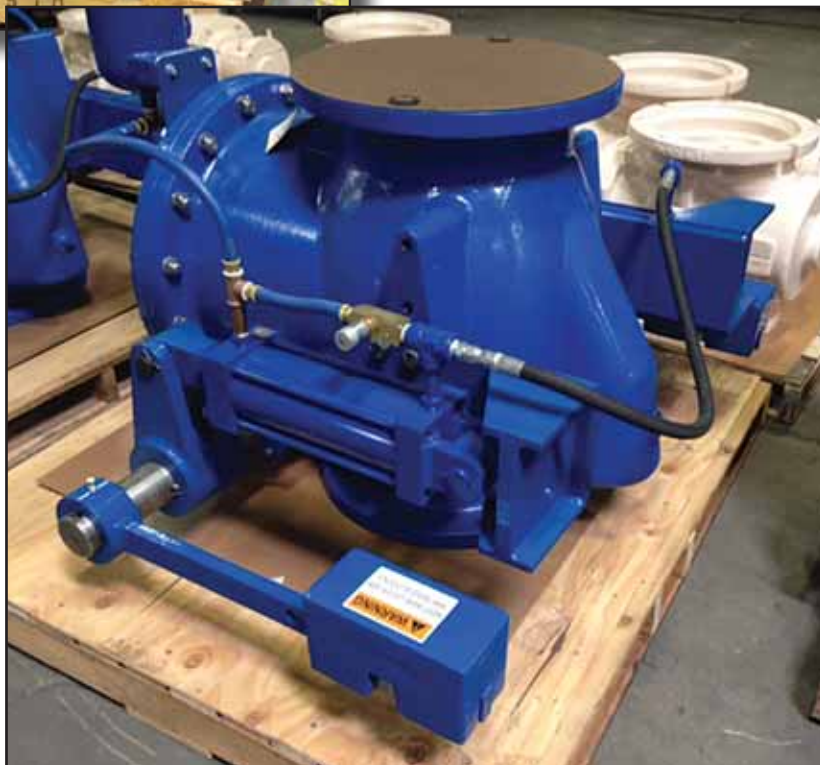

*2-Stage Side Oil Cushion
Swing Check Valve*

VAL-MATIC®



Tilted Disc® Check Valves



NSF/ANSI 61 & 372 Certified

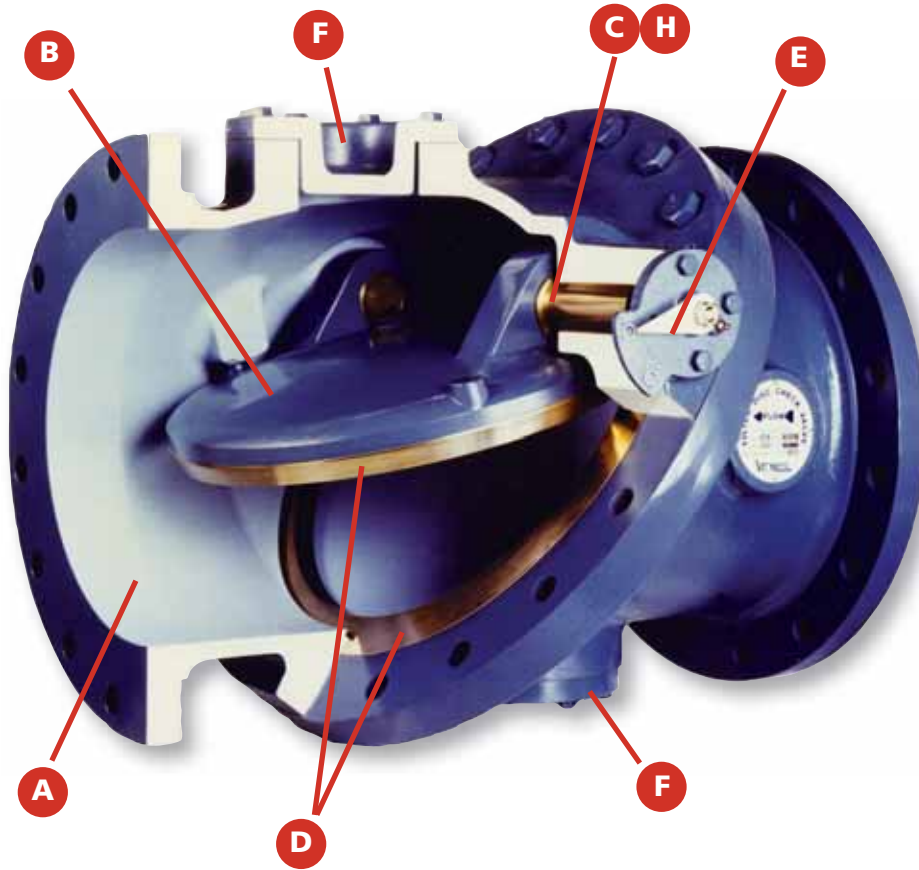

A. Energy Efficient Body

Ultra low headloss is the result of streamlined body contouring and 140% flow area through the body seat area.

B. Contoured Disc

The contoured disc provides ultra-low headloss and energy savings. A hydrodynamically balanced design provides lift and stabilization for variable conditions, minimum resistance to flow, and excellent flow characteristics. Contoured disc provides minimum headloss and energy savings. The disc counteraction and short 40° disc stroke results in quick closure minimizing reverse flow and surge potential.

C. Pivot Pins & Bushings

Maximum strength is achieved by utilizing large diameter pins and bushings constructed of high tensile aluminum bronze material. These materials provide superior wear and gall resistance as a result of their high Brinnell Hardness (BHN) and selected difference in hardness between mating parts.

D. Triple-Offset Seating Geometry

Leak tight seating and long life are achieved at all working pressures by utilizing triple-offset seating geometry which provides excellent sealing and low wear characteristics. The offsets allow the disc edge to lift off the seat during opening without sliding or binding.

E. Disc Position Indicator

Direct connection provides precise indication of the disc position at all times. Standard on sizes 6" and larger.

F. Inspection Ports

The ports allow access to the upstream and downstream sides of the seat for system maintenance and serve as mounting pads for optional dashpots. Inspection port covers are contoured to be flush with body interior to minimize turbulence.

G. Surge Control

Bottom Mounted Oil Dashpots control final stage of closing to reduce slamming associated with systems having rapid flow reversal characteristics. Top Mounted Oil Dashpots are directly connected to the disc and provide full open and close control of the valve disc to further reduce the potential for surges and water hammer.

H. Offset Pivot

The offset pivot counteraction divides the disc by a one-third/two-third proportion which reduces slamming by providing a self-cushioning effect.

The Tilted Disc® Check Valve is the premier check valve in the Val-Matic family. It offers unrivaled versatility, reliability, and a significant cost savings over the life of the valve. While some valves are ideally suited to a specific application or orientation, the Tilted Disc® Check Valve is preferred in any number of installation configurations and a wide range of media such as raw water, cooling water, treated water and wastewater effluent.

In single pump systems or systems where only one pump is operating at a time, Tilted Disc® Check Valves are commonly used with both centrifugal and turbine pumps where flow rates are in the range of 4-20 ft/sec and pressures up to 400 PSI.

For pumping systems with multiple pumps, surge considerations, and high capacity, Tilted Disc® Check Valves with oil dashpots are ideal. Depending on the system pressure, multiple pumps can cause a rapid flow reversal upon system shut-down and the flow rate can vary constantly. The Tilted Disc® Check Valve is offered with optional top or bottom mounted oil dashpots to control disc closure in multiple pump systems even after a power failure.

In closed surge tank applications, it is critical to have a check valve close rapidly to prevent reverse flow through the pump after pump stoppage. The Tilted Disc® Check Valve with bottom mounted dashpot is the ideal solution in this application; it allows the valve to close rapidly and cushion the last 10% of travel without the need for an external power source.

Val-Matic Tilted Disc® Check Valves are used worldwide to offer superior service and features in any number of applications and environments. Further information on specific application parameters and the benefits of the Tilted Disc® Check Valve are available online at www.valmatic.com.



Tilted Disc® Check Valve with Well Service Air Valve on Vertical Turbine Pump.



Tilted Disc® Check Valve with Top Mounted Oil Dashpot.



Tilted Disc® Check Valve on Discharge of Centrifugal Pump.



Tilted Disc® Check Valve with Bottom Mounted Oil Dashpot.

The Val-Matic Tilted Disc® Check Valve provides energy efficient operation while easily handling the most severe and demanding applications with features such as non-slam closure, wear resistance, leak tight seating, and surge control. This high performance check valve excels in any number of operating conditions and has the added benefit of extremely low headloss characteristics.

Energy Efficiency - Cost Savings

The Tilted Disc Check Valve conserves energy and provides the lowest operating cost, because it provides the lowest pressure loss characteristics of any check valve available today. Ultra-low headloss is the result of streamlined body contouring and a hydrodynamically designed disc, (Figure 1) in combination with a 140% flow area through the body seat. The energy savings realized by using a 30" Tilted Disc Check Valve instead of a conventional swing check valve may result in a 40 year energy cost savings of \$189,232 (See page 10).

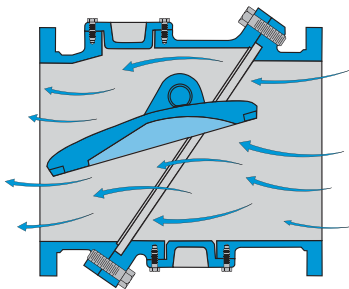

Figure 1

Non-Slam Closing - System Protection

The non-slam closing characteristics of the Tilted Disc Check Valve are achieved by utilizing a short disc stroke, unique disc counteraction, and fixed pivot pins without stem packing. The short disc stroke, resulting from the angled seat design, is only 40° as compared to the approximate 80° to 90° stroke found in a conventional swing check valve (Figure 2). This short stroke reduces the closing time of the valve disc. The reduced closing time minimizes flow reversal and water hammer normally associated with the sudden stopping of reverse flow.

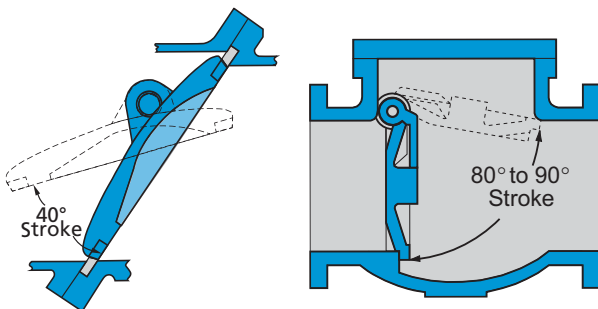

Figure 2

The disc counteraction is the result of an offset pivot, which divides the disc into approximately a one-third/two-thirds proportion (Figure 3). This allows the two-thirds of flow that passes below the pivot to be counteracted by the one-third that passes above the pivot. This counteraction reduces slamming by providing a self-cushioning effect not found in conventional swing check valves.

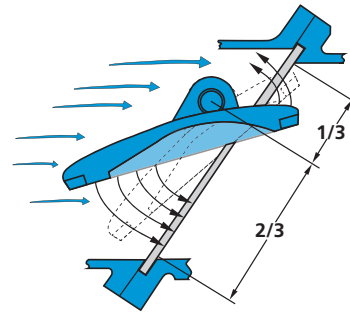

Figure 3

Finally, while conventional swing check valves have rotating stems with packing, the Tilted Disc Check Valve's disc rotates freely on fixed pins. This provides low inertia and friction to accelerate disc closure.

High Performance Triple Offset Seating

Leak tight seating and long life are achieved by utilizing triple offset seating geometry. The disc pivot is offset from both the face of the seat (1) and the centerline of the seat (2). These offsets, together with the inclined offset of the conical seat (3), provide non-binding, self-releasing seating (Figure 4). The offsets allow the disc edge to lift off the seat during opening without sliding or binding (Figure 5).

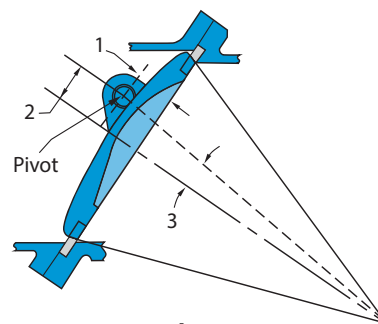

Figure 4

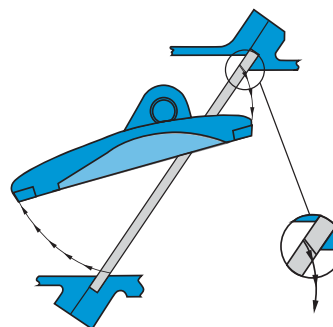

Figure 5

Wear Resistance - Long Life

Extended valve life is the result of excellent wear resistance through advanced features including disc stabilization, triple offset seating, and a meticulous selection of materials of construction for mating surfaces. Different grades of aluminum bronze are used for the disc edge and seat and the pivot pins and bushings to provide a significant difference in hardness, thereby reducing wear and galling. The hydrodynamic design of the disc shape provides lift and disc stabilization during flow (See Figure 1). Tests conducted by an independent laboratory showed the disc to be extremely stable during both low and high flow conditions, thereby minimizing wear associated with disc flutter.

Proof of Design Testing

To demonstrate the excellent seating and wear resistant qualities of the Tilted Disc Check Valve, an extensive full-scale cycle test was conducted and witnessed by an independent engineering consulting firm. After more than 100,000 cycles, the Val-Matic Tilted Disc Check Valve had less than 10% of the allowable leakage for new valves as called for in the testing sections of AWWA and MSS standards.

Surge Control

The dashpot configurations include high pressure oil cylinders and full rated disc connections. With oil dashpots, the disc is precisely controlled using flow control valves to regulate the flow of oil out of the cylinder, as opposed to an air cushion which only produces a minimal dampening effect due to the compressibility of air.

To select the proper valve configuration, several criteria must be considered. The number of pumps and the static head will affect how rapidly the water column will reverse when a pump is stopped. The type of pump control will affect the required closing characteristics of the valve. Typical types of control include on-off, soft-start, variable speed, and electrically operated control valves. The length of the piping system is used to estimate surges from changes in flow velocity. The type of surge relief system dictates the required closing time for the valve. Surge tanks require a quick-closing valve to prevent the loss of stored water back through the pump. The criteria listed above are used to select the best valve configuration as follows:

Base Valve

The base valve will provide non-slam closure in low service pumping applications. Base valves are typically used when the static head is less than 100 feet in single or multiple pump application. A common application is the filter backwash pumps in a water treatment plant.

On very long systems, a power operated control valve is sometimes used. The control valve is electrically wired to the pump control and is programmed to slowly open and close to gradually change the flow rate in the system over a 30-300 second period. However, after a power outage, the control valve may not be capable of closing rapidly enough to prevent back spinning of the pump or loss of water from a surge tank. In these cases, a Tilted Disc Check Valve is often installed downstream of the control valve (See Base Valve Application Figure).

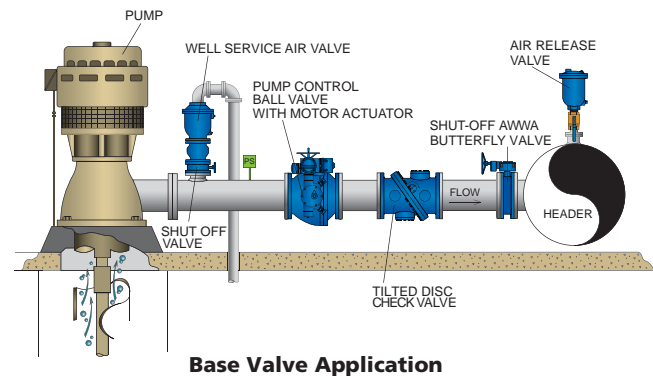

Bottom Mounted Oil Dashpot

Dashpots are used on high service pumping applications where there is a propensity for rapid flow reversal. The dashpot consists of a hydraulic cylinder and snubber rod which contacts the disc during closing. The dashpot controls the last 10% of valve closure to prevent slamming of the disc and reduce water hammer.

The valve is effective on shorter length systems with static heads up to the valve rating. The dashpot is also used on longer systems where rapid flow reversal occurs due to the use of surge tanks or in multiple pump systems.

Top Mounted Oil Dashpot

The top mounted oil dashpot controls both the full opening and full closing stroke of the valve. Also, the last 10% of travel of valve closure is independently controlled by an adjustable hydraulic cylinder cushion.

With the top mounted oil dashpot, the disc is mechanically linked to a hydraulic cylinder and linkage is designed to withstand the full thrust of the disc when subjected to full system pressure.

Valves equipped with top mounted oil dashpots have been used in extreme service applications up to the full flow and pressure rating of the valve. When there is insufficient space to provide a straight run of pipe between the pump and the valve, the top mounted dashpot will control the disc movement and prolong the life of the valve.

Principle of Operation

Bottom Mounted Oil Dashpot

Bottom Mounted Oil Dashpots (BMOD) reduce the water hammer potential associated with systems having rapid flow reversal characteristics. These critical conditions are normally found in piping systems which have high shut-off heads, and/or use surge tanks. BMOD's are not directly connected to the disc, allowing the valve disc to open freely without restriction and close freely for 90% of its travel. During the remainder of its travel, the disc will contact the dashpot snubber rod. Once contact is made, the final 10% of disc movement is cushioned to an adjustable rate best suited for the application.

The BMOD is a self-contained oil operated system which has an air gap between the system media and the dashpot cylinder. This air gap prevents any possibility of the pressurized hydraulic fluid from entering the valve housing and contaminating the system media. The BMOD is installed in the bottom inspection port of the Tilted Disc Check Valve and is available on valve sizes 6" and larger. When necessary, the unit can also be field installed.

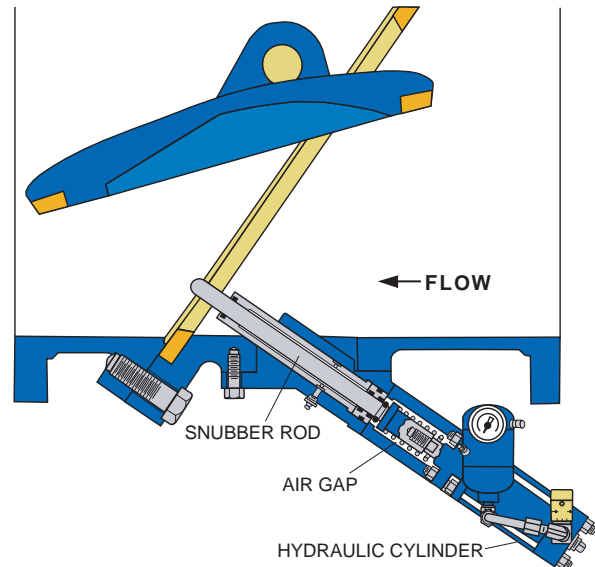

Sequence of Operation

The last 10% of closing of the check valve can be controlled by an optional hydraulic dashpot cylinder to prevent slamming where rapid flow reversals are expected. The cylinder rod pushes against a snubber rod, which in turn makes contact with the valve disc. Both sides of the hydraulic cylinder are connected to a pressurized oil accumulator, which is held at the maximum line pressure plus 50 psi. Since the cylinder piston has a greater pressure area opposite the rod end, the air pressure in the accumulator will tend to extend the rod past the seat to control the last 10% of disc closure. The opening spring is also designed to extend the rod in case air pressure is lost.

Opening Stroke:

When the water system pump is started, the water pressure will force the check valve disc open. The air pressure in the accumulator and the spring will extend the cylinder and snubber rod into the valve port.

Closing Stroke:

When the water system pump is stopped, the weight of the disc and reverse flow of water will force the check valve disc closed, thereby striking the snubber rod. The snubber rod will push on the cylinder rod in the direction shown and force oil through the adjustable flow control valve. The flow control valve will control the speed of closure for the last 10% of valve travel in typically 1 to 5 seconds.

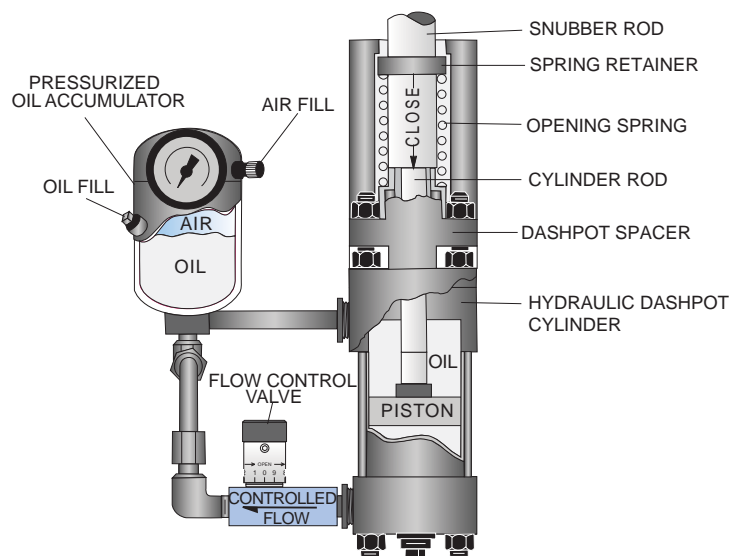

Principle of Operation

Top Mounted Oil Dashpot

The Top Mounted Oil Dashpot (TMOD) is directly connected to the disc and provides full control of the valve disc to further reduce the potential for surges and water hammer. The unit provides single stage adjustable speed control of the disc's travel to the open position, thereby reducing system pressure surges upon pump start-up. Two stage control is provided during valve closure, reducing the water hammer and surges associated with rapid flow reversal systems. The first stage controls 90% of the disc closure, while the second stage controls the final, critical 10% of closure. All controls are independent of each other and can be field adjusted to best suit the application. For example, the first stage of closing can be at a slower rate than the opening rate, with the final 10% of closure at an even slower rate.

Tilted Disc Check Valves with dashpots are not intended to replace system surge control equipment, but rather to further minimize the slamming and water hammer associated with conventional swing check valves. The TMOD is a self-contained oil operated system that has an air gap spacer between the system media and dashpot. The air gap prevents any possibility of the hydraulic fluid from entering the system and contaminating the line media. TMOD's are available for all valve sizes 6" and larger. Val-Matic's Exclusive Quick Change Coupling is provided to facilitate removal of the cylinder should it be necessary without removal of the valve from the line.

Val-Matic's Exclusive Quick Change Coupling

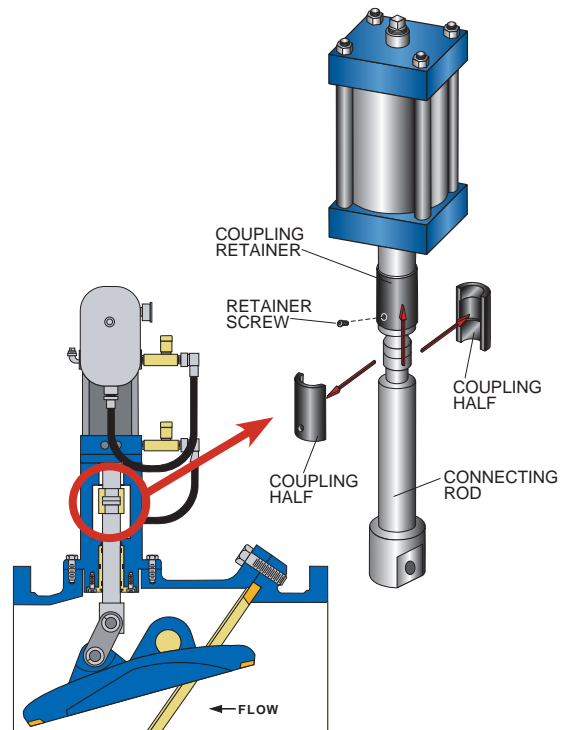

Sequence of Operation

The opening and closing of the check valve can be controlled by an optional hydraulic dashpot cylinder to reduce valve slamming and control surges. The cylinder rod extends out the bottom of the cylinder and is connected to the disc of the check valve. When the check valve disc is opened or closed by the forces of the flowing water in the pipeline, the cylinder rod is stroked in the dashpot cylinder in two stages. In the first stage, two flow control valves are set to independently control the opening and closing times, typically 5 to 30 seconds. In the second stage, a cylinder hydraulic cushion will control the last 10% of closure in 1 to 5 seconds.

Opening Stroke:

When the water system pump is started, the water column will force the check valve disc open, thereby pushing the cylinder rod upward. The oil over the cylinder piston will become pressurized and flow through the open flow control valve and into the pressurized oil accumulator typically in 5-30 sec. Oil will also be drawn into the lower portion of the cylinder through the check portion of the close flow control valve and the vented oil accumulator.

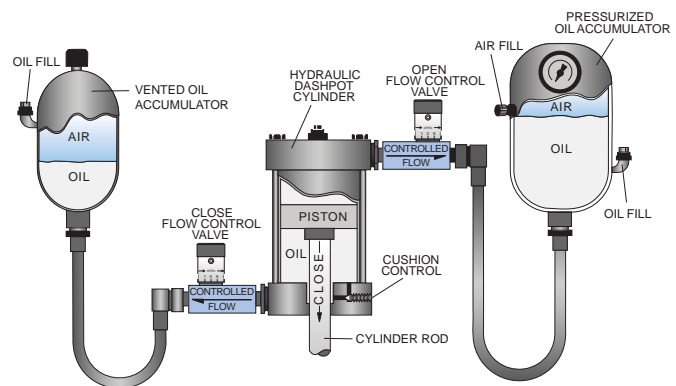

Closing Stroke:

When the water system pump is stopped, the weight of the disc and reverse flow of the water will force the check valve disc closed, thereby pulling the cylinder rod down. The oil under the cylinder piston will become pressurized and flow through the close flow control valve and into the vented oil accumulator typically in 5-30 sec. Oil will also flow into the top of the cylinder from the pressurized oil accumulator through the check portion of the open flow control valve. The pressurized oil accumulator is maintained at 20% of the water line pressure to assist in valve closure.

Final 10% of Closure:

During the last 10% of closure, the larger diameter portion of the cylinder rod enters a cushion chamber in the lower head of the dashpot cylinder. The speed of closure during the last 10% of closure can be controlled further using the cushion control adjustment screw located on the cylinder head, typically 1 to 5 seconds.

Application Recommendation

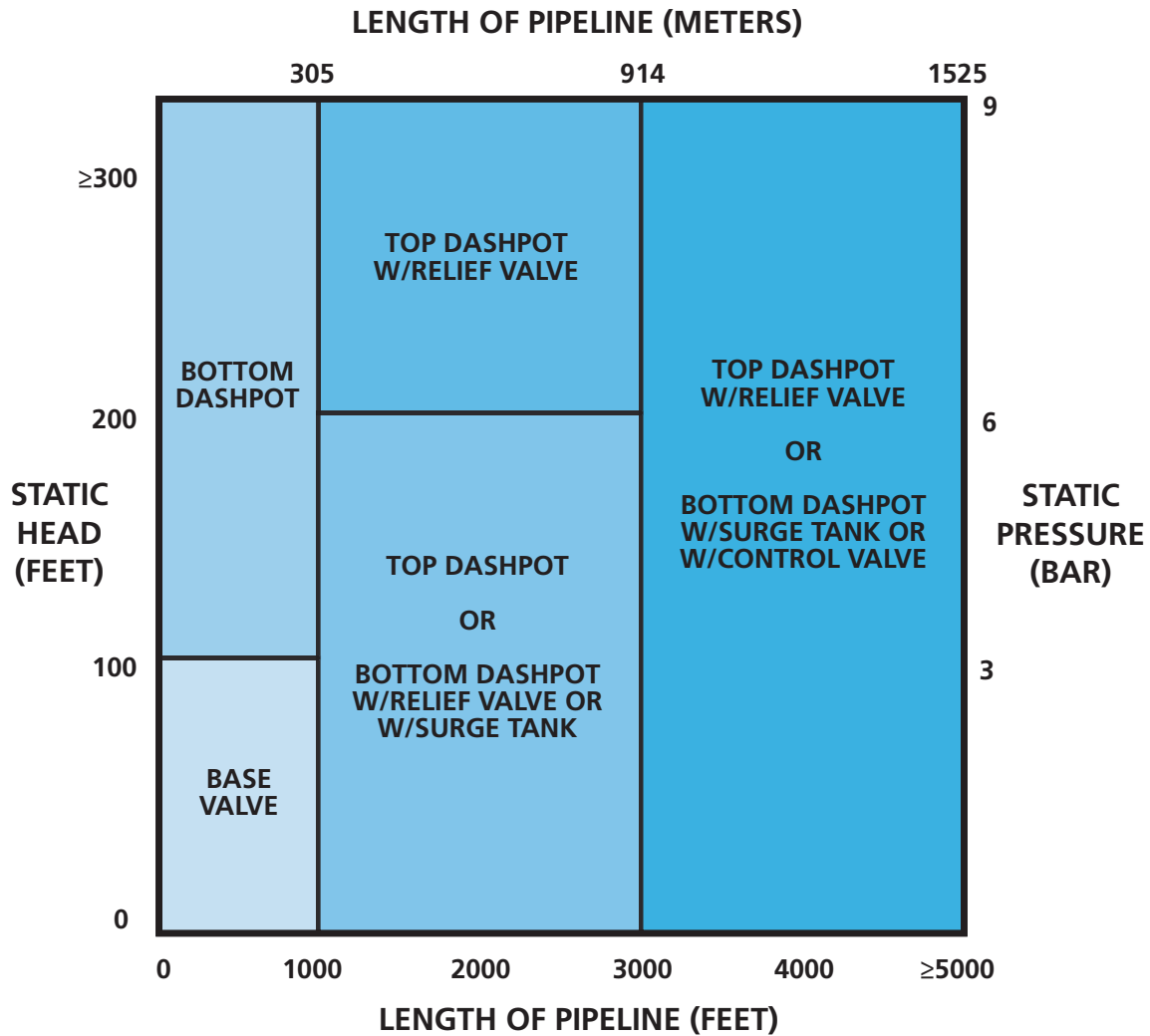

The application graph illustrates the range of use for three valve configurations: 1) base valve, 2) bottom mounted oil dashpot, and 3) top mounted oil dashpot. For example, on a 2,500 ft. long water transmission main operating at 150 ft. of head, a Tilted Disc Check Valve with a top mounted oil dashpot would be selected. Or, if a surge relief system is provided, then the bottom mounted oil dashpot configuration may be used.

RECOMMENDATION FOR APPLICATION OF VAL-MATIC TILTED DISC® CHECK VALVES				
TYPE OF INSTALLATION	LENGTH	STATIC HEAD	SURGE RELIEF SYSTEM	RECOMMENDED CHECK VALVE
Single Pump	0-1000 ft.	0-100 ft.	NONE	Base Valve
Multiple Pump	0-1000 ft.	0-100 ft.	NONE	Base Valve
Single/Multiple Pump	0-1000 ft.	> 100 ft.	NONE	Valve w/BMOD
Single/Multiple Pump	1000-3000 ft.	0-200 ft.	NONE	Valve w/TMOD
Single/Multiple Pump	1000-3000 ft.	0-200 ft.	Relief Valve/Surge Tank	Valve w/BMOD
Single/Multiple Pump	1000-3000 ft.	> 200 ft.	Relief Valve	Valve w/TMOD
Single Pump	> 3000 ft.	> 50 ft.	Relief Valve	Valve w/TMOD
Single Pump	>3000 ft.	> 50 ft.	Surge Tank/Control Valve	Valve w/BMOD

Pressure Ratings

The Val-Matic Tilted Disc® Check Valve is offered in three different flange classes: 125, 150 and 250. This chart indicates the maximum non-shock pressures for each flange class.

NOTE: The Ductile Iron 9600 series, Class 150 is rated for 285 PSI and can be bolted directly to flanges with 150 or 125 ANSI class drilling.

MAXIMUM NON-SHOCK PRESSURE - PSI (BAR)							
Temperature	Series 9800			Series 9700			Series 9600
	Class 125			Class 250**			Class 150**
	Cast Iron			Cast Iron	Ductile Iron		Ductile Iron
	3"-12"	14"-24"	30"-60"	3"-12"	14"-24"	30"-48"	3"-60"
	80-300mm	350-600mm	800-1500mm	80-300mm	350-600mm	800-1200mm	80-1500mm
100°F	200 (13.8)	150 (10.3)	150 (10.3)	400 (27.6)	300 (20.7)	300 (20.7)	285 (19.7)
150°F							270 (18.6)
200°F	190 (13.1)	135 (9.3)	115 (7.9)	370 (25.5)	280 (19.3)	250 (17.2)	260 (17.9)
250°F	*	*	*	355 (24.5)	270 (18.6)	225 (15.5)	250 (17.2)
Hydrostatic Test Pressure	300 (20.7)	230 (15.9)	230 (15.9)	600 (41.4)	450 (31.0)	450 (31.0)	450 (31.0)

*For service above 200°F use Series 9700 or 9600.

**All Ductile Iron flanges are flat faced.

Materials of Construction

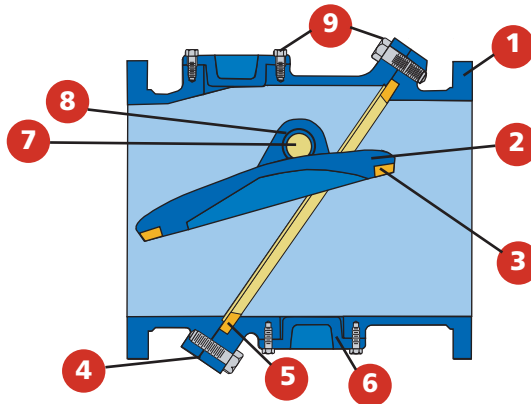

ASSY NO.	COMPONENT	STANDARD	OPTIONAL
1	Body 3" - 10"	Cast Iron ASTM A126, Class B	Ductile Iron, Carbon Steel
	Body 12" - 60"	Cast Iron ASTM A126, Class B	Ductile Iron, Carbon Steel
2	Disc 3" - 10"	Aluminum Bronze ASTM B148, Alloy C954000	Stainless Steel
	Disc 12"	Ductile Iron ASTM A536 Grade 65-45-12	Carbon Steel
	Disc 14" - 60"	Cast Iron ASTM A126, Class B	Ductile Iron, Carbon Steel
3	Disc Ring 3" - 10"	NA	NA
	Disc Ring 12" - 60"	Aluminum Bronze ASTM B271, Alloy C95500	Stainless Steel
4	Body O-ring	Buna-N ASTM D2000	EPDM

ASSY NO.	COMPONENT	STANDARD	OPTIONAL
5	Seat Ring 3" - 10"	Aluminum Bronze ASTM B271, Alloy C95500	Stainless Steel
	Seat Ring 12" - 60"	Aluminum Bronze ASTM B271, Alloy C95400	Stainless Steel
6	Inspection Hole Cover	Cast Iron ASTM A126, Class B	Ductile Iron, Carbon Steel
7	Pivot Pin	Aluminum Bronze ASTM B505, Alloy C95500	Stainless Steel
8	Bushing 3" - 10"	NA	NA
	Bushing 12" - 60"	Aluminum Bronze ASTM B271, Alloy C95400	Stainless Steel
9	Bolts	Alloy Steel	Stainless Steel

Headloss Chart

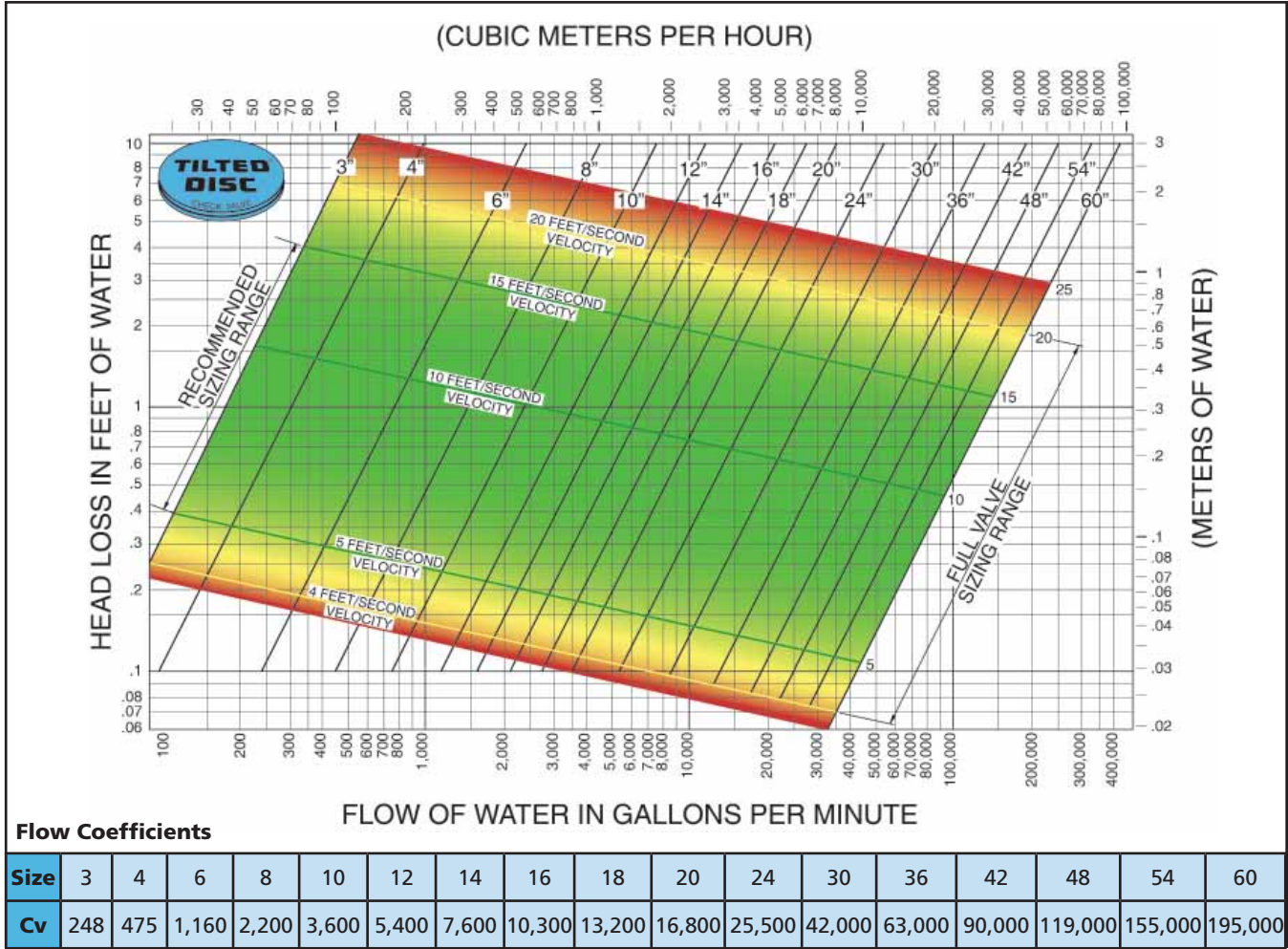

Energy Cost Savings

The Tilted Disc® Check Valve possesses the lowest headloss of any check valve available today, allowing the least amount of energy during system operation to be consumed. The continuous electrical energy savings that result from using the Val-Matic Tilted Disc® Check Valve can be seen in the table below for 30" valves. This information was calculated using **Val-Matic's Energy Cost Calculator** on www.valmatic.com.

Valve Type	Flow Coefficient (K)	Headloss (ft)	40-Year Energy Cost*	40-Year Tilted-Disc Energy Cost	40-Year Tilted-Disc Savings
Globe-Style Control Valve	5.70	12.8	\$1,111,980	\$122,903	\$989,077
Silent Check Valve	3.00	6.7	\$585,253	\$122,903	\$462,350
Swing Check Valve	1.60	3.6	\$312,135	\$122,903	\$189,232
Tilted Disc® Check Valve	0.63	1.4	\$122,903		

*Assumes 50% usage, \$.08/kw-hr, 12 ft/sec, 0.8 efficiency.

Installation Dimensions

Base Valve

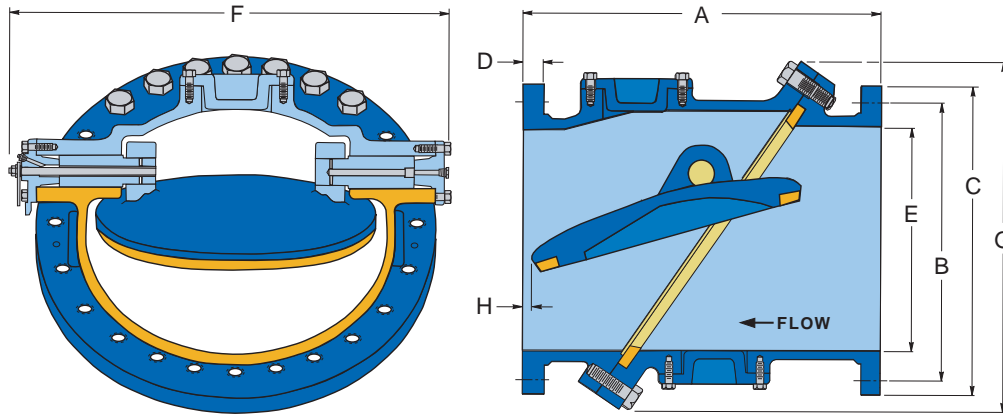

Dimensions in Inches

Valve Size*	Model No.	ANSI Class	A	B	C	D	E	F	G	H	Valve Weights (lbs)
3	9803	125	9.50	6.00	7.50	0.94	3.00	12.00	9.00	2.25	41
	9703	250		6.63	8.25	1.13					48
	9603	150		6.00	7.50	0.94					41
4	9804	125	11.50	7.50	9.00	0.94	4.00	13.00	10.00	2.63	91
	9704	250		7.88	10.00	1.25					103
	9604	150		7.50	9.00	0.94					91
6	9806	125	15.00	9.50	11.00	1.00	6.00	16.00	13.00	2.88	168
	9706	250		10.63	12.50	1.44					213
	9606	150		9.50	11.00	1.00					168
8	9808	125	19.50	11.75	13.50	1.13	8.00	19.00	16.00	3.50	322
	9708	250		13.00	15.00	1.63					376
	9608	150		11.75	13.50	1.13					322
10	9810	125	24.50	14.25	16.00	1.19	10.00	23.00	18.00	4.50	470
	9710	250		15.25	17.50	1.88					557
	9610	150		14.25	16.00	1.19					470
12	9812	125	24.00	17.00	19.00	1.25	12.00	26.00	21.00	2.75	735
	9712	250		17.75	20.50	2.00					850
	9612	150		17.00	19.00	1.25					735
14	9814	125	30.00	18.75	21.00	1.38	14.00	29.00	25.00	4.13	997
	9714	250		20.25	23.00	2.13					1153
	9614	150		18.75	21.00	1.38					997
16	9816	125	30.00	21.25	23.50	1.44	16.00	32.00	28.00	0.75	1330
	9716	250		22.50	25.50	2.25					1535
	9616	150		21.25	23.50	1.44					1330
18	9818	125	33.00	22.75	25.00	1.56	18.00	36.00	30.00	2.50	1561
	9718	250		24.75	28.00	2.38					1893
	9618	150		22.75	25.00	1.56					1561
20	9820	125	32.00	25.00	27.50	1.69	20.00	39.00	32.00	0.50	1932
	9720	250		27.00	30.50	2.50					2302
	9620	150		25.00	27.50	1.69					1932
24	9824	125	38.00	29.50	32.00	1.88	24.00	46.00	37.00	0.50	3062
	9724	250		32.00	36.00	2.75					3646
	9624	150		29.50	32.00	1.88					3062
30	9830	125	52.00	36.00	38.75	2.13	30.00	55.00	47.00	2.75	5312
	9730	250		39.25	43.00	3.00					6038
	9630	150		36.00	38.75	2.13					5312
36	9836	125	59.50	42.75	46.00	2.38	36.00	65.00	51.00	2.00	8189
	9736	250		46.00	50.00	3.38					8893
	9636	150		42.75	46.00	2.38					8189
42	9842	125	62.50	49.50	53.00	2.63	42.00	73.00	59.00	0.00	11578
	9742	250		52.75	57.00	3.69					12919
	9642	150		49.50	53.00	2.63					11578
48	9848	125	65.00	56.00	59.50	2.75	48.00	82.00	69.00	-3.75	15926
	9748	250		60.75	65.00	4.00					17246
	9648	150		56.00	59.50	2.75					15926

*Contact Factory for sizes larger than 48".

Installation Dimensions

Bottom Mounted Oil Dashpot

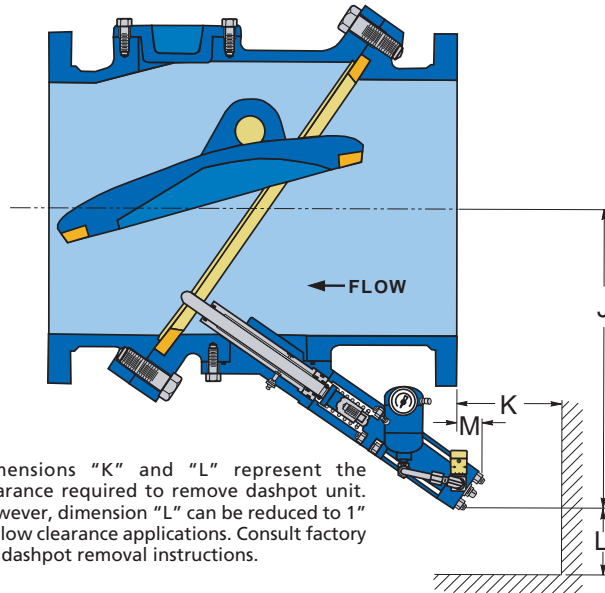

Dimensions "K" and "L" represent the clearance required to remove dashpot unit. However, dimension "L" can be reduced to 1" for low clearance applications. Consult factory for dashpot removal instructions.

Dimensions in Inches							
Valve Size*	Model No.	ANSI Class	J	K	L	M	Valve Weights (lbs)
6	9806B	125	16.00	12.00	3.00	9.00	200
	9706B	250					245
	9606B	150					200
8	9808B	125	17.00	11.00	4.00	8.00	360
	9708B	250					414
	9608B	150					360
10	9810B	125	18.00	9.00	5.00	5.00	508
	9710B	250					595
	9610B	150					508
12	9812B	125	20.00	11.00	5.00	7.00	801
	9712B	250					916
	9612B	150					801
14	9814B	125	21.00	8.00	5.00	4.00	1063
	9714B	250					1219
	9614B	150					1063
16	9816B	125	23.00	9.00	5.00	5.00	1414
	9716B	250					1619
	9616B	150					1414
18	9818B	125	24.00	7.00	5.00	3.00	1646
	9718B	250					1978
	9618B	150					1646
20	9820B	125	25.00	8.00	6.00	3.00	2019
	9720B	250					2389
	9620B	150					2019
24	9824B	125	27.00	4.00	6.00	1.00	3156
	9724B	250					3740
	9624B	150					3156
30	9830B	125	35.00	6.00	8.00	1.00	5566
	9730B	250					6292
	9630B	150					5566
36	9836B	125	39.00	2.00	8.00	5.00	8445
	9736B	250					9149
	9636B	150					8445
42	9842B	125	43.00	5.00	8.00	5.00	11917
	9742B	250					13258
	9642B	150					11917
48	9848B	125	52.00	8.00	8.00	2.00	16262
	9748B	250					17582
	9648B	150					16262

*Contact Factory for sizes larger than 48".

Installation Dimensions Top Mounted Oil Dashpot

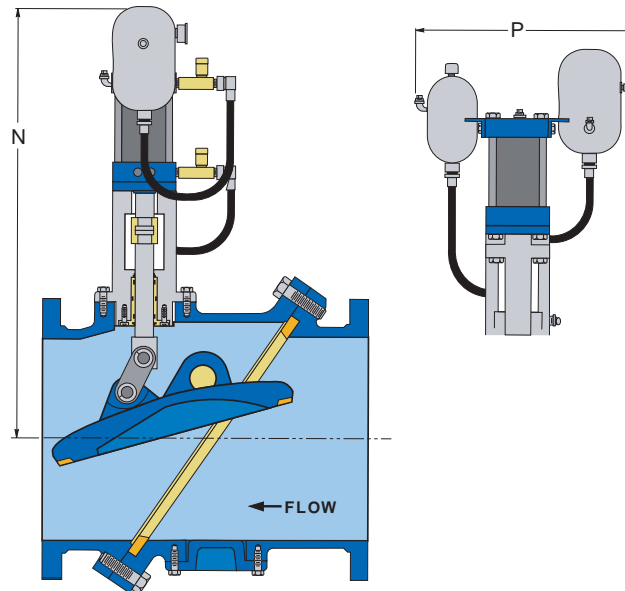

Dimensions in Inches					
Valve Size*	Model No.	ANSI Class	N	P	Valve Weights (lbs)
6	9806T	125	23.00	12.00	227
	9706T	250			272
	9606T	150			227
8	9808T	125	29.00	17.00	426
	9708T	250			480
	9608T	150			426
10	9810T	125	31.00	17.00	574
	9710T	250			661
	9610T	150			574
12	9812T	125	34.00	21.00	932
	9712T	250			1047
	9612T	150			932
14	9814T	125	36.00	21.00	1195
	9714T	250			1351
	9614T	150			1195
16	9816T	125	43.00	24.00	1643
	9716T	250			1848
	9616T	150			1643
18	9818T	125	45.00	24.00	1873
	9718T	250			2205
	9618T	150			1873
20	9820T	125	53.00	28.00	2398
	9720T	250			2768
	9620T	150			2398
24	9824T	125	56.00	28.00	3537
	9724T	250			4121
	9624T	150			3537
30	9830T	125	66.00	36.00	6261
	9730T	250			6987
	9630T	150			6261
36	9836T	125	78.00	36.00	9234
	9736T	250			9938
	9636T	150			9234
42	9842T	125	89.00	43.00	12928
	9742T	250			14269
	9642T	150			12928
48	9848T	125	99.00	43.00	18081
	9748T	250			19401
	9648T	150			18081

*Contact Factory for sizes larger than 48".

Series 9000 Specification

SCOPE

- 1.1 This specification covers the design, manufacture, and testing of 3 in. (80 mm) through 60 in. (1500mm) Tilted Disc Check Valves suitable for pressures up to 400 psig (2750 kPa) water service.
- 1.2 The Check valves shall be of the Tilted Disc metal seated, full body type capable of accepting optional bottom or top mounted oil dashpots.

STANDARDS AND APPROVALS

- 2.1 The valves used in potable water service shall be certified to NSF/ANSI 61 Drinking Water System Components - Health Effects and certified to be Lead-Free in accordance with NSF/ANSI 372.
- 2.2 A 20 in. (500 mm) valve or larger shall be proof of design cycle tested through 250,000 cycles in the horizontal position and leak tested at the rated pressure. The leakage rate shall be less than 1 fluid ounce per hour per inch of valve size after the test.
- 2.3 Manufacturer shall have a quality management system that is certified to ISO 9001 by an accredited, certifying body.

CONNECTIONS

- 3.1 The valves shall be provided with drilled flanges in accordance with ANSI B16.1 for Class 125 Cast iron flanges or ANSI B16.42 for Class 150 and 300 ductile iron flanges. Iron flanges shall be flat faced.
- 3.2 Flanged inspection ports shall be provided upstream and downstream of the valve disc for inspection or use with optional dashpots on 6 in. and larger valves.

DESIGN

- 4.1 The valve body shall consist of two sections bolted together with a central diagonal flange inclined at an angle of 55 degrees. The inlet body section shall contain a seat ring positioned and captured by the diagonal flange. The outlet body section shall accept eccentrically located pivot pin trunnions with sealed covers and lubrication grease fittings.
- 4.2 The eccentric pivot trunnions shall be located to divide the disc into approximately 1/3 and 2/3 proportions and also allow the seating surface of the disc to rotate away from the seating surface of the seat ring without contact. Clearance shall be provided between the pivot pin and bushing when the disc is seated to prevent binding and to ensure a tight seal. The minimum pivot pin diameter shall be as shown below.

Valve Size (IN)	Pin Diameter (IN)	Valve Size (IN)	Pin Diameter (IN)
3	0.562	20	2.75
4	0.625	24	3.25
6	1.125	30	3.75
8	1.375	36	4.25
10	1.625	42	4.875
12	1.875	48	5.75
14	2.125	54	6.00
16	2.375	60	6.75
18	2.50		

- 4.3 The flow area through the valve body inlet and outlet shall be equal to the nominal pipe size and gradually increase to an area 40 percent greater at the valve seat.
- 4.4 A position indicator shall be supplied on 6 in. and larger valves and visually show disc position at all times.
- 4.5 The valve disc and seat shall have a seating surface finish of 32 micro-inch or better to ensure positive seating at all pressure. The leakage rate shall not exceed one-half of the allowable rate allowed by AWWA Standard C508 or 0.5 oz (15 ml) per hour per inch (mm) of valve size.
- 4.6 6" (150 mm) and larger valves should be capable of accepting a field installed Bottom Mounted Oil Dashpot.
- 4.7 The valve flow way shall be contoured and unrestricted to provide full flow areas at all locations within the valve. Full flow shall be based on an open stroke of 40 degrees to assure stabilization of the disc when open. Cv flow coefficients shall be verified by an independent testing laboratory.

MATERIALS

- 5.1 The valve body shall be constructed of ASTM A126 Class B cast iron for Class 125 and Class 250 valves up to 10 in. (250mm). 12 in. (300mm) and larger Class 250 and Class 150 valves shall be constructed of ductile iron ASTM A536 Grade 65-45-12.
- 5.2 The disc in sizes up to 10 in. (250mm) shall be one-piece construction with integral seat and constructed of ASTM B148 Alloy C95400 aluminum bronze. 12 in. (300mm) and larger discs shall be ASTM A536 Grade 65-45-12 ductile iron. Discs furnished for 12" (300mm) and larger valves with top oil dashpots shall be constructed of ASTM A126 Class B cast iron. The disc seating ring shall be ASTM B271 Alloy C95500 centrifugally cast aluminum bronze. The mating seat ring located in the body shall be ASTM B271 Alloy C95400 centrifugally cast aluminum bronze.
- 5.3 The pivot pins shall be ASTM B505 Alloy C95500 aluminum bronze and shall be guided by a bushing constructed of ASTM B505 Alloy C95400 aluminum bronze (12 in. and larger valves).

OPTIONS

- 6.1 Single or double bypass piping shall be provided when specified with piping and valves in sizes shown below.

Valve Size (IN)	By-Pass Size (IN)
6-8	1.5
10-14	2.0
16-24	3.0
30-60	4.0

- 6.2 A NEMA-4 machine tool type limit switch with DPDT contacts shall be provided when specified. The switch shall be mounted to the inspection cover and have an adjustable trip arm for sensing the closed position.
- 6.3 A bottom mounted oil dashpot shall be factory installed (12" (300 mm) and larger) in the upstream inspection port when specified to provide hydraulic control of the final 10% of valve closure and reduce water hammer normally associated with rapid flow reversal conditions on pump shut down. The dashpot shall consist of a high pressure hydraulic cylinder with a minimum bore size as shown below, adjustable external flow control valve, pressurized oil reservoir and piping designed to control the closing speed of the last 10% of travel in 1-5 seconds. A dashpot spacer which connects the cylinder to the valve shall have an air gap to prevent hydraulic fluid from entering the valve and contaminating the water system. A snubber rod fitted with O-ring seals and rod wiper scrapers shall make contact with the lower portion of the disc during closure.

Valve Size (IN)	Bore Diameter (IN)
6-10	1.50
12-14	2.00
16-24	2.50
30-36	3.25
42-48	4.00
54-60	5.00

- 6.4 A top mounted oil dashpot shall be factory installed in the downstream inspection port when specified to provide independent hydraulic control of the valve opening and closing strokes to reduce water hammer normally associated with pump operation. The dashpot shall consist of a high pressure hydraulic cylinder with a minimum bore size as shown below and with internal cushion adjustment, two external flow control valves, a pressurized oil reservoir with a minimum size as shown below, a stainless steel non-pressurized reservoir, and piping. The unit shall independently control the opening and closing stroke in the range of 5-30 seconds. Additionally,

the closing stroke shall be two-stage with the last 10% of closing travel dampened with the internal cylinder cushion. A dashpot spacer which connects the cylinder to the valve shall have an air gap to prevent hydraulic fluid from entering the valve and contaminating the water system. A connecting rod with a minimum diameter as shown below and fitted with O-ring seals and rod wiper scrapers shall be linked to an integrally cast clevis on the disc. The connecting rod shall be attached to the cylinder rod with a quick change coupling constructed of 17-4 PH stainless steel. The cylinder rod, connecting rod, and coupling shall be held in place by a coupling retainer to allow decoupling of the cylinder while the check valve is under pressure.

Valve Size (IN)	Bore Size (IN)	Reservoir Size (GAL)	Rod Diameter (IN)
6	2.50	0.1	1.000
8-10	3.25	0.3	1.375
12-14	4.00	0.6	1.750
16-18	5.00	1.1	2.000
20-24	6.00	2.5	2.500
30	7.00	6.0	3.500
36-42	8.00	6.0	4.000
48-60	10.00	10.0	5.000

- 6.5 The valve interiors and exteriors shall be coated with an NSF/ANSI 61 certified fusion bonded epoxy in accordance with AWWA C550 when specified.

MANUFACTURE

- 7.1 The valves shall be hydrostatically tested at 1.5 times their rated cold working pressure. Additional tests shall be conducted per AWWA, ANSI, MSS or API standards when specified. When requested, the manufacturer shall provide test certificates, dimensional drawings, parts list drawings, and operation and maintenance manuals.
- 7.2 The exterior of the valve shall be coated with a universal alkyd primer. The valve interior shall be coated with an epoxy coating approved for potable water.
- 7.3 The Tilted Disc® Check Valves shall be Series 9000, 9000B (with bottom oil dashpot), or 9000T (with top oil dashpot) as manufactured by Val-Matic® Valve & Mfg. Corporation, Elmhurst, IL. USA or approved equal.

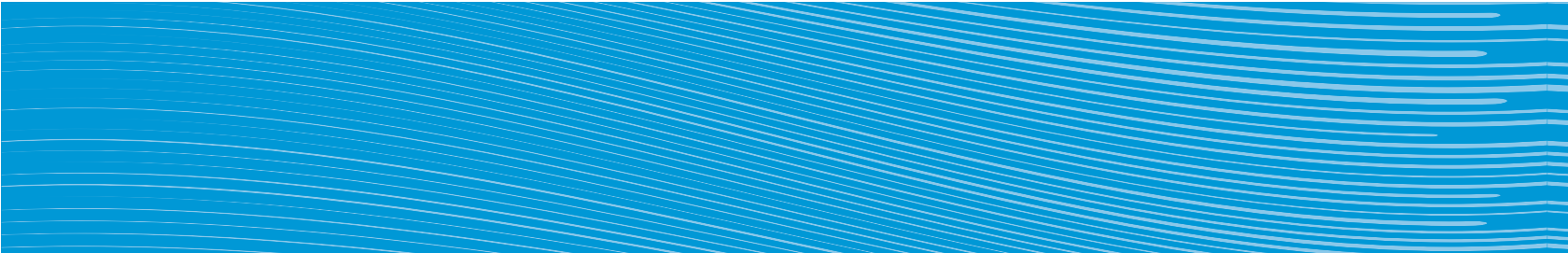

Tilted Disc® Check Valves



VAL-MATIC®



Dual Disc®
Check Valves



UL Listed/FM Approved
NSF/ANSI 61 & 372 Certified

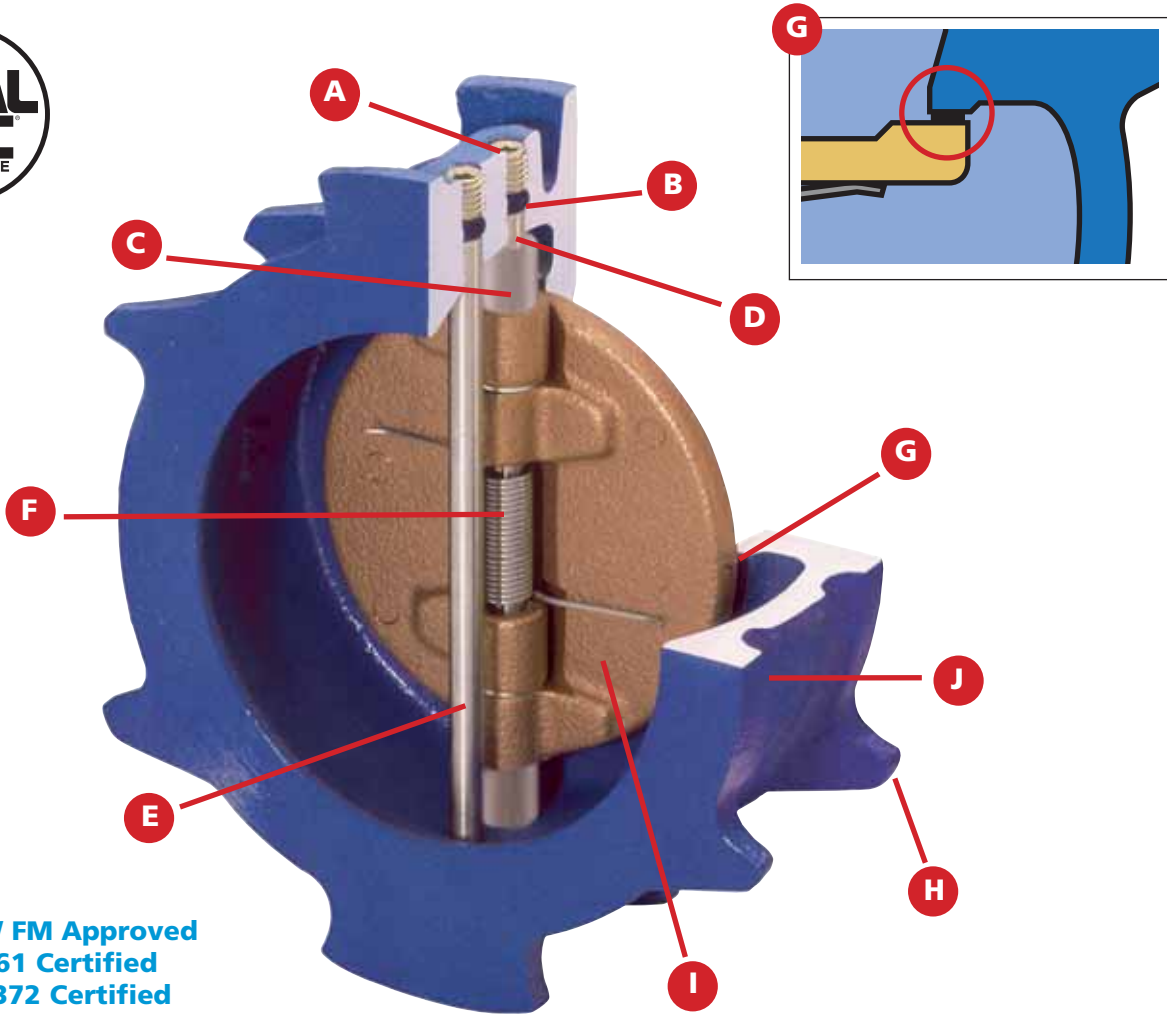

- * UL Listed / FM Approved
- * NSF/ANSI 61 Certified
- * NSF/ANSI 372 Certified

A. Retainer Plugs

Retains hinge and stop pins while providing compression to stabilization spheres.

B. Stabilization Spheres

Stabilizes hinge and stop pins, preventing vibration and wear.

C. Thrust Bearings

Reduces friction and wear during disc action.

D. Hinge Pin

Heavy duty construction with increased bearing surface and strength.

E. Stop Pin

Positions and stabilizes discs in full open position to prevent disc flutter.

F. Spring

Specially designed torsion spring closes discs upon pump shutdown minimizing water hammer normally associated with valve shut-off. Also provides for Lift and Pivot disc action. Cycle tested 50,000 cycles to assure long, trouble free life.

G. Vulcanized Seat

Pressure sensitive seating with full disc overlap provides positive seating at high and low pressures.

H. Alignment Lugs

Provides for precise alignment in ANSI 125 and ISO PN10 and PN16 installations.

I. Disc

Dual Disc design increases valve sensitivity to flow, allowing discs to close quickly on pump shut-down.

J. Body

Choose between compact wafer design to minimize space requirements (pictured) or grooved end for ease of installation. Both provide low initial installation cost and minimal maintenance. Compact wafer style reduces installation time, minimizes space required for installation, and results in low initial unit cost. Lug style available, contact factory.

Specifiable Features

With today's demanding system requirements, engineers must specify piping components that are both cost efficient and reliable. The design of the Val-Matic Dual Disc® Check Valve answers those needs by incorporating many unique characteristics not found in similar check valves. 2" - 12" (50 -300mm) valves include ductile iron construction, with a 250 psi (17.2 BAR), cold working pressure rating. They are UL listed, FM approved and available in Wafer (ANSI 125, ISO PN10, ISO PN16) and Grooved End IPS connections. Sizes 14" (350mm) and larger are available in cast and ductile iron.

Installation Cost

Choose between compact wafer design to minimize space requirements or grooved end for ease of installation. Both provide low initial installation cost and minimal maintenance for horizontal or vertical flow up installations. The following quality features you expect from Val-Matic can be found in both the wafer and grooved end valves.

Operating Cost

Careful attention to inlet contouring and streamlined flow design, combined with an optimal flow area, results in low pressure loss characteristics. The resulting low power consumption translates into dollar savings throughout the long life of the valve.

Product Reliability

Design features such as Lift and Pivot Disc Action, Stabilization Spheres, Pressure Sensitive Seating, Disc Stabilization, Disc Seal Overlap and Flow Sensitive Closure, combined with careful selection of materials of construction, reflect Val-Matic's efforts to build a quality valve. These efforts result in a Cost Efficient and Reliable product that will provide many years of trouble free service.

Lift and Pivot Disc Action

This feature, designed to provide longer valve life, is activated during the opening and closing cycles. It works by a combination of clearance between the pivot pin and disc bores, and the placement of the legs of the torsion spring. With this design the disc will always lift first at the pivot on opening, and not return until the disc is closed, preventing wear between disc and seat surfaces.

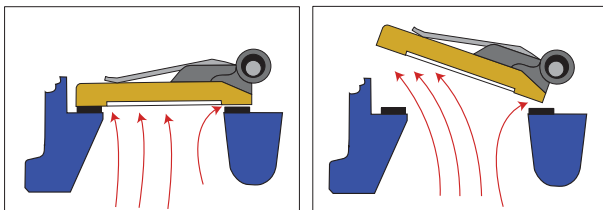

Stabilization Spheres

The resilient, synthetic spheres inserted into the hinge and stop pin holes are compressed against the pins and effectively stabilize them during flow conditions, eliminating vibration and wear.

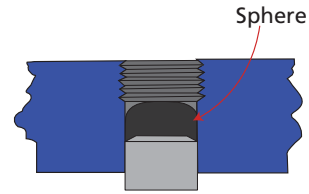

Pressure Sensitive Seating

This design provides for minimum disc-to-seat contact at low pressures, and maximum contact at high pressures resulting in positive seating under all conditions.

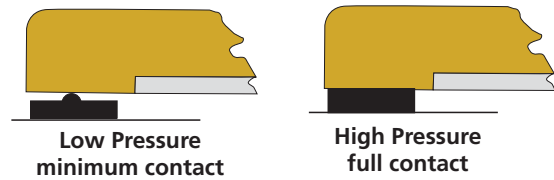

Disc Stabilization

When the valve is fully open, the discs are positioned on a slight angle, causing the flow velocity to force the discs firmly against the stop pin. The ensuing vector forces act to stabilize the disc during flow conditions thereby preventing excessive wear due to disc "flutter."

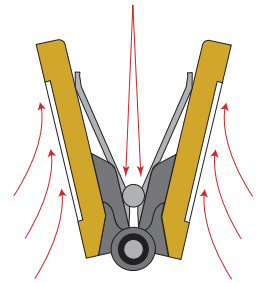

Disc Seal Overlap

Contact between the seal and the disc is uniquely designed to eliminate indentation ridges found in designs which do not allow the disc to fully overlap the seal. Indentation ridges caused by valve designs with discs smaller in diameter than the seal can result in valve leakage.

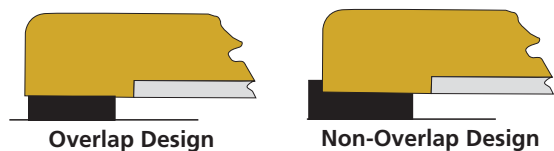

Flow Sensitive Closure

The torsion spring closes the valve when the flow is reduced, preventing flow reversal and lessening the potential for water hammer normally associated with conventional swing check valves.

Ratings/Construction

Dual Disc®
Check Valves

PRESSURE RATINGS

MAXIMUM NON-SHOCK WORKING PRESSURE RATINGS, PSIG			
Temp. F	Ductile Iron	Cast Iron	
	2"-12"	14"-24"	30"-60"
150	250	150	150
200	235	135	115
250	220	125	85
Hydro Test*	500	230	230

MAXIMUM NON-SHOCK WORKING PRESSURE RATINGS, BAR			
Temp. C	Ductile Iron	Cast Iron	
	50-300 mm	350-600 mm	750-1500 mm
65	17.2	10.3	10.3
95	16.2	9.3	7.9
120	15.2	8.6	5.9
Hydro Test*	35	16	16

*14" & 16" valves are hydro tested to 300 psi (20 bar)

MATERIALS OF CONSTRUCTION

COMPONENT	STANDARD	OPTIONAL
Body 2" - 12" (50-300 mm)	Ductile Iron ASTM A536, Grade 65-45-12	-
Body 14" - 60" (350-1500 mm)	Cast Iron ASTM A126, Class B	Ductile Iron ASTM A536, Grade 65-45-12
Disc 2" - 12" (50-300 mm)	Bronze ASTM B584, C87600	-
Disc 14" - 60" (350-1500 mm)	Aluminum Bronze ASTM B148, C95200	Ductile Iron ASTM A536, Grade 65-45-12 Electroless Nickel Plating, Stainless Steel ASTM A351 Grade CF8M
Seat	Buna-N	Viton
Spring 2" - 16" (50-400mm)	T316 Stainless Steel, ASTM A313	Inconel X750
Spring 18" - 60" (450-1500mm)	17-7PH Stainless Steel, ASTM A313	Inconel X750
Coatings	Universal Primer	Fusion Bonded Epoxy

Contact Factory for other materials.

Headloss Chart

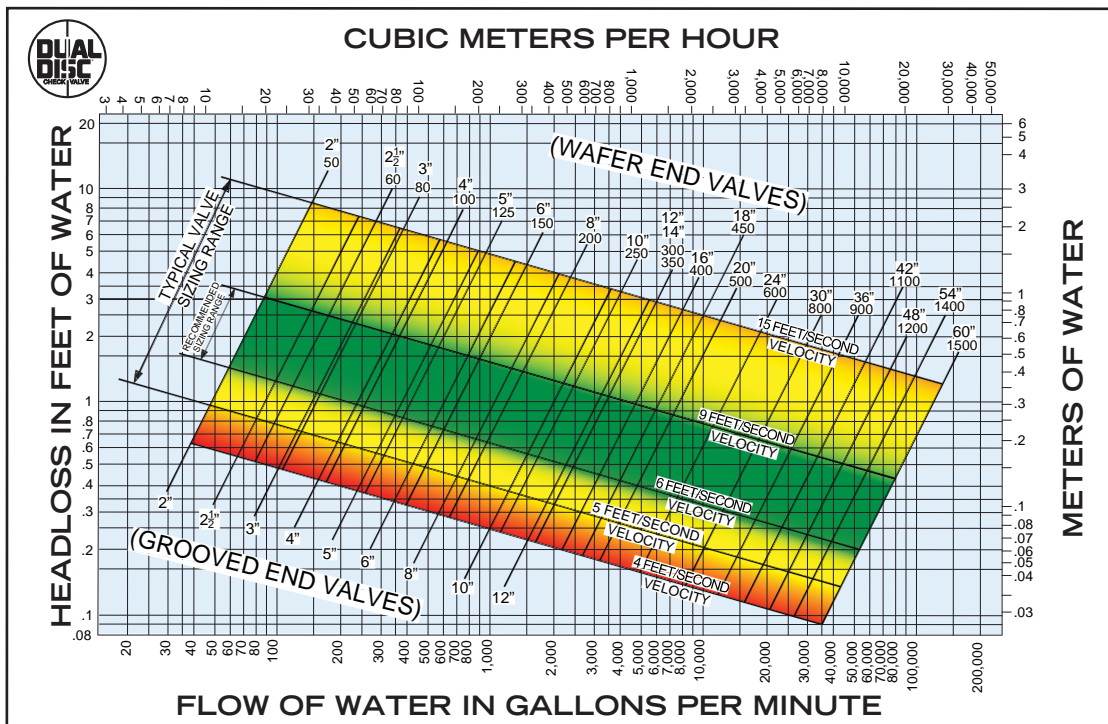

Flow Coefficients

Size	2	2 1/2	3	4	5	6	8	10	12	14	16	18	20	24	30	36	42	48	54	60
Cv 8800G	77	129	209	358	573	898	1740	3180	4950	-	-	-	-	-	-	-	-	-	-	-
Cv 8800W	76	161	224	400	648	1060	1890	3340	5270	5200	7200	9400	12000	18500	33000	50000	72000	97000	130000	180000

Installation Dimensions

Wafer Style

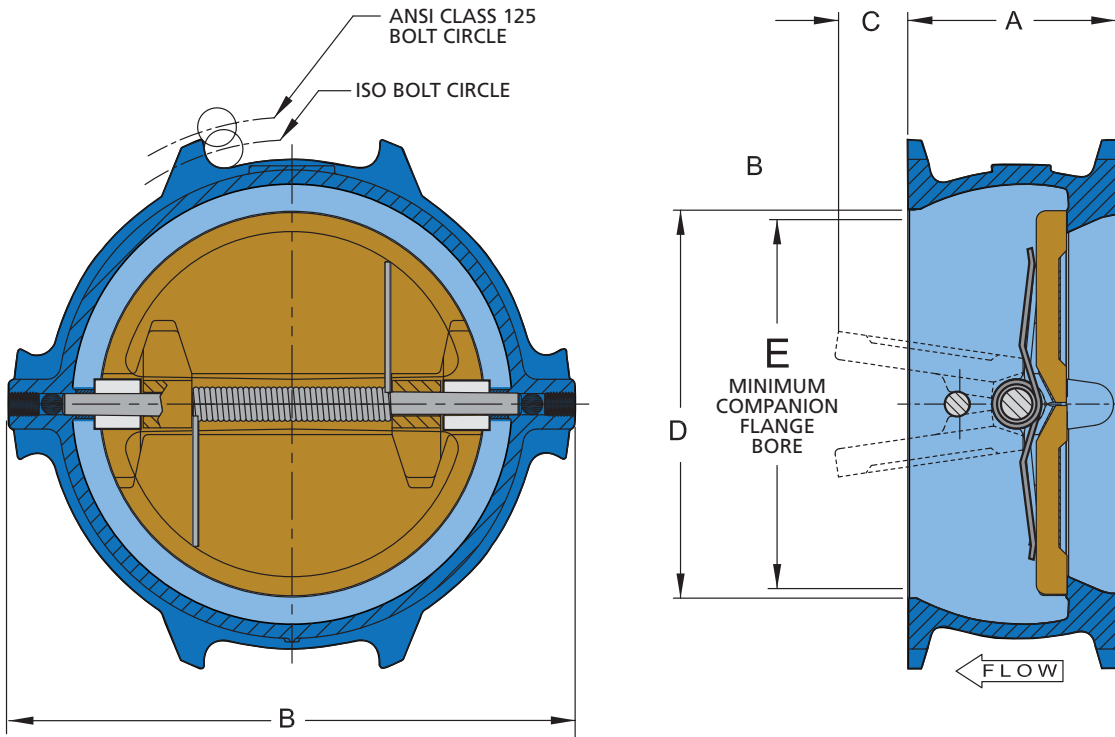

Dimensions in Inches							
Valve Size (in)	Valve Size (mm)	A	B	C	D	E	Wafer Wt. (lb)
2	50	2.13	5.13	-	2.88	-	4
2 1/2	60	2.38	6.00	0.13	3.50	1.31	5
3	80	2.63	5.63	0.18	3.88	1.69	7
4	100	2.63	7.75	0.63	4.75	3.06	9
5	125	3.25	7.56	0.81	5.50	3.63	13
6	150	3.75	8.63	0.81	6.25	4.25	19
8	200	5.00	12.25	1.00	8.00	5.50	41
10	250	5.50	14.75	2.06	10.25	8.50	65
12	300	7.12	17.38	1.94	12.00	9.25	94
14	350	7.25	17.75	3.25	14.38	12.50	187
16	400	7.50	20.25	4.50	16.38	15.00	270
18	450	8.00	21.63	5.38	18.38	17.00	330
20	500	8.38	23.88	6.38	20.25	19.00	424
24	600	8.75	28.25	8.50	24.25	23.00	589
30	800	12.00	34.75	9.50	30.00	28.50	1112
36	900	14.50	41.25	12.00	36.00	34.50	1864
42	1050	17.00	48.00	13.75	42.00	40.50	2889
48	1200	20.62	54.50	17.00	48.00	46.50	5525
54	1350	21.25	60.50	18.25	54.00	49.25	7000
60	1500	26.00	67.00	18.25	60.00	53.50	8500

Installation Dimensions

Grooved End Style

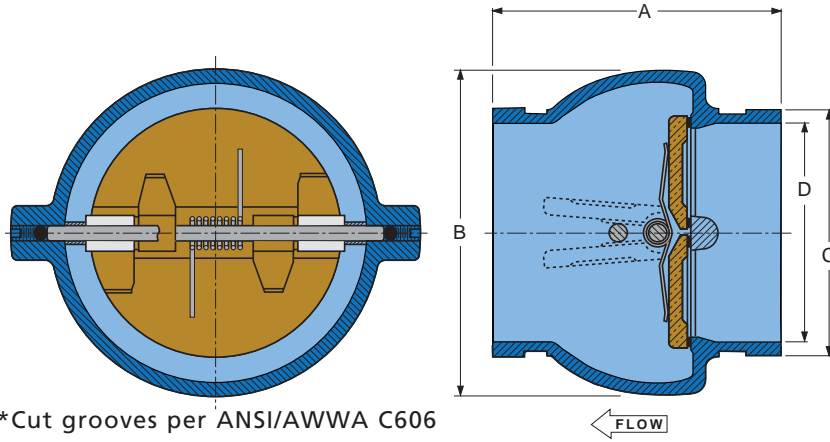

*Cut grooves per ANSI/AWWA C606

Dimensions in Inches						
Valve Size (in)	Valve Size (mm)	A	B	C	D	Grooved Wt. (lb)
2	50	4.66	4.12	2.38	2.00	4
2 1/2	60	4.90	4.88	2.88	2.41	5
3	80	5.31	5.38	3.50	2.94	8
4	100	5.38	6.00	4.50	3.91	9
5	125	5.72	7.06	5.56	4.89	13
6	150	6.00	8.12	6.62	5.92	18
8	200	6.72	10.03	8.62	7.91	30
10	250	7.78	12.38	10.75	10.00	56
12	300	8.18	14.38	12.75	11.94	87

Lug Style

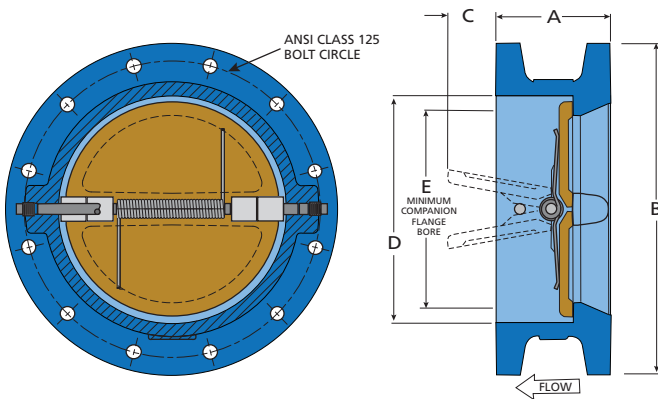

Dimensions in Inches						
Valve Size (in)	Valve Size (mm)	A	B	C	D	E
14	350	7.25	21.00	3.25	14.38	12.50
16	400	7.50	23.50	4.50	16.38	15.00
18	450	8.00	25.00	5.38	18.38	17.00
20	500	8.38	27.50	6.38	20.25	19.00
24	600	8.75	32.00	8.50	24.25	23.00
30	800	12.00	38.75	9.50	30.00	28.50
36	900	14.50	46.00	12.00	36.00	34.50
42	1050	17.00	53.00	13.75	42.00	40.50
48	1200	20.62	59.50	17.00	48.00	46.50
54	1350	21.25	66.25	18.25	54.00	49.50
60	1500	26.00	73.00	18.25	60.00	53.50

SCOPE

- 1.1 This specification covers the design, manufacture, and testing of 2 in. (50 mm) through 60 in. (1500 mm) Dual Disc Check Valves suitable for pressures up to 500 psig (3450 kPa) water service.
- 1.2 The Check Valve shall be of the dual disc, wafer style, or grooved end with torsion spring induced closure.

STANDARDS AND APPROVALS

- 2.1 The valves shall be designed, manufactured and tested in accordance with American Water Works Association Standard ANSI/AWWA C518.
- 2.2 The valves for use in fire protection systems shall be Underwriters Laboratories listed in sizes 2 1/2 in.- 12 in. and Factory Mutual approved in sizes in sizes 2 1/2 in. - 16 in.
- 2.3 The valves shall be certified to be Lead-Free in accordance with NSF/ANSI 372.
- 2.4 Manufacturer shall have a quality management system that is certified to ISO 9001 by an accredited, certifying body.

CONNECTIONS

- 3.1 Wafer style valves shall be provided in sizes 2 in. (50 mm) through 12 in. (300 mm) for installation between ANSI B16.1 Class 125 iron flanges, or between ISO 7005-2 PN10 or PN16 flanges.
- 3.2 Wafer style valves shall be provided in sizes 14 in. (350 mm) through 66 in. (1650 mm) for installation between ANSI B16.1 Class 125 or Class 250 iron flanges.
- 3.3 Grooved end valves shall be provided in 2 in. (50mm) through 12 in. (300mm) for installation on pipe with cut grooves per ANSI/AWWA C606 for steel IPS pipe.

DESIGN

- 4.1 The body shall be of one piece construction incorporating a vulcanized synthetic seal.
- 4.2 Seal design shall include a raised sealing bead for positive seating at both high and low pressures. The disc shall fully overlap the synthetic seal, preventing pressure indentations.
- 4.3 Opening and closing of the valve shall utilize a lift and pivot action to prevent seal wear and ensure long seal life.
- 4.4 Disc stabilization in the full open position shall be provided by the use of a stop pin.
- 4.5 The stop and hinge pins shall be stabilized by the use of synthetic spheres to prevent wear due to vibration during operating conditions. The design shall incorporate a raised seat and 1/2 in. body wall to disc clearance to ensure proper operation after long periods of inactivity and potential corrosion buildup.
- 4.6 Closure shall be assisted with a torsion spring to provide a cracking pressure of 0.25 psig.

MATERIALS

- 5.1 The valve body on sizes 2-12 in. shall be constructed of ASTM A536 Grade 65-45-12 ductile iron. On sizes 14-66 in. the valve body shall be constructed of ASTM A126 Class B cast iron for Class 125 and Class 250 valves.
- 5.2 For sized 2-12 in. the disc shall be constructed of ASTM B584, Alloy C87600 (2-12 in.) cast bronze. For sizes 14 in. and up, the disc shall be constructed of ASTM B148, Alloy C95200 cast aluminum bronze.
- 5.3 The hinge pins and stop pins shall be Type 316 stainless steel.
- 5.4 The torsion spring shall be ASTM A313 Type 316 stainless steel up to 16 in. (400 mm) and ASTM A313 Type 17-7 PH on 18 in. (450 mm) and larger sizes.
- 5.5 The seal shall be Buna-N per ASTM D2000-BG.

OPTIONS

- 6.1 Optional Disc materials for sizes 14 in. and up include ASTM A536 Grade 65-45-12 ductile iron with electroless nickel plating and ASTM A351 Grade CF8M stainless steel.
- 6.2 Air Service Spring (Series 8900W)
- 6.3 Optional Spring material includes Inconel X750.
- 6.4 For 14 in. and larger, end connections shall be lug with threaded flange lugs or full diameter threaded flanges when specified for end of line service.
- 6.5 Valve interiors and exteriors shall be coated with an NSF/ANSI 61 certified fusion bonded epoxy in accordance with AWWA C550 when specified.

MANUFACTURE

- 7.1 The valves shall be hydrostatically tested at 1.5 or 2 times their rated cold working pressure. A seat closure test at 1.5 or 2 times the valve rating shall be conducted to demonstrate zero leakage. Additional tests shall be conducted per AWWA, ANSI, MSS or API standards when specified. When requested, the manufacturer shall provide test certificates, dimensional drawings, parts list drawings, and operation and maintenance manuals.
- 7.2 The exterior of the valve shall be coated with a universal alkyd primer.
- 7.3 Dual Disc® Check Valves shall be Series #8800W (Wafer Style), Series #8800G (Grooved End), Series #8800 (Class 125), #8700 (Class 250), or #8800L (Lug) as manufactured by Val-Matic® Valve & Mfg. Corporation, Elmhurst, IL. USA or approved equal.

*Dual Disc® Check Valve
Hydrotesting*



Sure Seal Foot Valves



Designed and Manufactured
to AWWA C508
NSF/ANSI 61 Certified
NSF/ANSI 372 Certified

Sure Seal Foot Valves

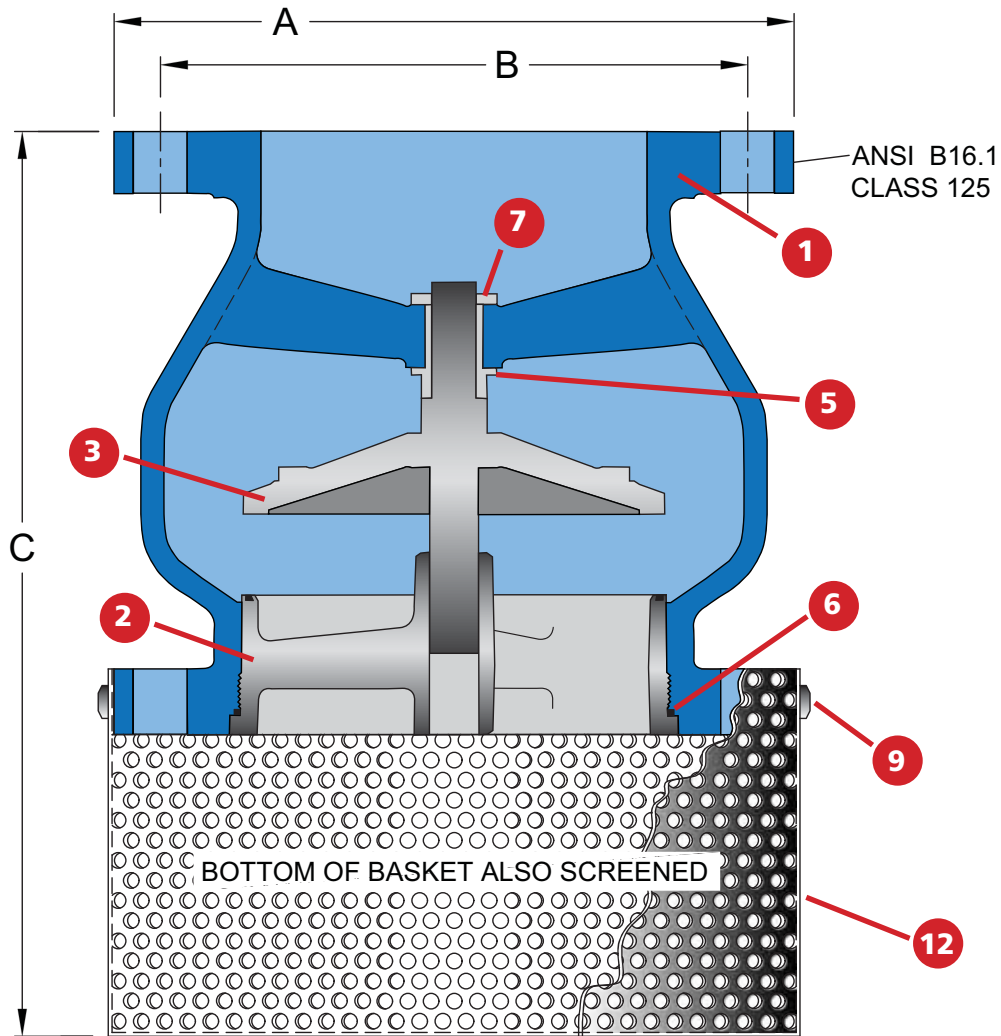

Sure Seal
Foot Valves

Construction		
Part No.	Name	Material
1	Body	Cast Iron
2	Seat	Bronze/Buna-N
3	Disc	Bronze
5	Bushing	Bronze
6	O-Ring	EPDM
7	Bushing Retainer	Bronze
9	Screen Retainer	Stainless Steel
11	Bolts	Steel
12	Screen	Stainless Steel

Dimensions				
Size*	Model	A	B	C
2	1902A	6.00	4.75	8.44
2-1/2	1925A	7.00	5.50	8.44
3	1903A	7.50	6.00	8.69
4	1904A	9.00	7.50	9.94
5	1905A	10.00	8.50	12.19
6	1906A	11.00	9.75	18.25
8	1908A	13.50	12.50	22.19
10	1910A	16.00	14.25	21.88
12	1912A	19.00	17.00	23.44

* Contact Factory for larger sizes.

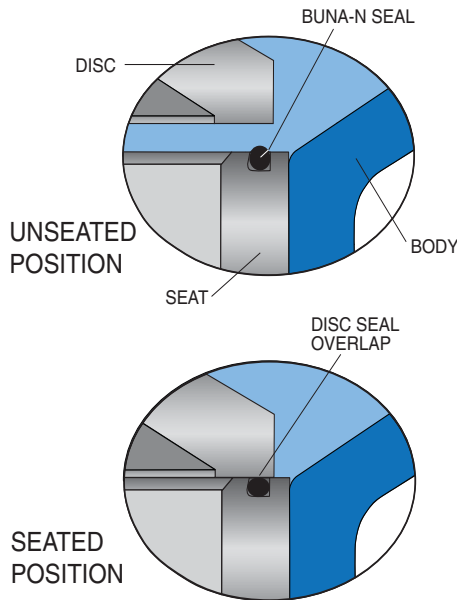

Design of the Sure Seal Foot Valve evolved through a need for a valve that could provide positive sealing action at various pressure ranges without seal damage along with silent operation.

The Val-Matic Sure Seal Foot Valve satisfies these requirements plus low headloss thru its full ported area and heavy duty stainless steel basket screening.

The unique seating design provides initial contact with the valve disc and the Buna-N ring, providing a drop-tight seal. As the pressure increases, the Buna-N ring is compressed slightly and the disc makes contact with the metal portion of the valve seat, preventing any further compression of the Buna-N ring. The Buna-N ring will continue to provide the "drop-tight seating" during the higher pressure ranges without damage from the increased pressure loading.

Specification

SCOPE

- 1.1 This specification covers the design, manufacture, and testing of 2 in. (50 mm) through 42 in. (1067mm) Sure Seal Foot Valves suitable for pressures up to 200 psig (1375 kPa) water service.
- 1.2 The Foot Valve shall be of the full flow globe style designed to provide silent operation, positive seating, and full flow area.

STANDARDS AND APPROVALS

- 2.1 The valves shall be certified to be Lead-Free in accordance with NSF/ANSI 372.
- 2.2 Manufacturer shall have a quality management system that is certified to ISO 9001 by an accredited, certifying body.

CONNECTIONS

- 3.1 The Foot Valves shall be provided with flanges in accordance with ANSI B16.1 for Class 125 iron flanges.

DESIGN

- 4.1 The valve design shall incorporate a center guided disc, guided at opposite ends and having a short linear stroke that generates a flow area equal to the pipe size.
- 4.2 All component parts shall be field replaceable without the need of special tools. A replaceable guide bushing shall be provided and held in position by threaded bushing retainer.
- 4.3 The valve disc shall be concave to the flow direction providing for disc stabilization, maximum strength, and a minimum flow velocity to open the valve.

- 4.4 The valve disc and seat shall have a seating surface finish of 32 micro-inch or better to ensure positive seating at all pressures. A Buna-N seal shall be provided on the seat to provide for zero leakage at both high and low pressures without overloading or damaging the seal. The seal design shall provide both a metal to metal and a metal to Buna-N seal.
- 4.5 A heavy duty basket type screen shall be bolted to the inlet flange outside diameter and provide 3-4 times the pipe area.

MATERIALS

- 5.1 The valve body shall be constructed of ASTM A126 Class B cast iron.
- 5.2 The seat and plug shall be ASTM B584 Alloy C87600 cast bronze. Optional trim material include ASTM A351 Grade CF8M stainless steel.
- 5.3 The basket screen shall be stainless steel, Type 304.

MANUFACTURE

- 6.1 The valves shall be hydrostatically tested at 1.5 times their rated cold working pressure. Additional tests shall be conducted per AWWA, ANSI, MSS or API Standards when specified. When requested, the manufacturer shall provide test certificates, dimensional drawings, parts list drawings, and operation and maintenance manuals.
- 6.2 The exterior of the valve shall be coated with a universal alkyd primer.
- 6.3 Foot Valves shall be Series #1900 as manufactured by Val-Matic® Valve & Mfg. Corporation, Elmhurst, IL, USA or approved equal.



Sure Seal Foot Valve

VAL-MATIC®

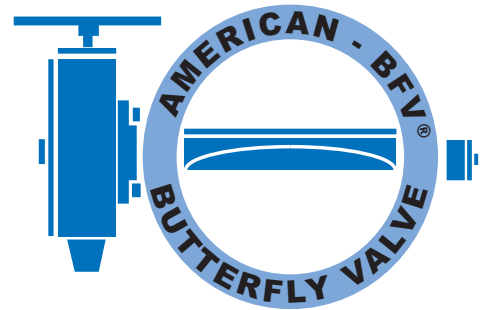

AWWA
Rubber Seated
Butterfly Valves



Meets AWWA C504 & C516
NSF/ANSI 61 & 372 Certified

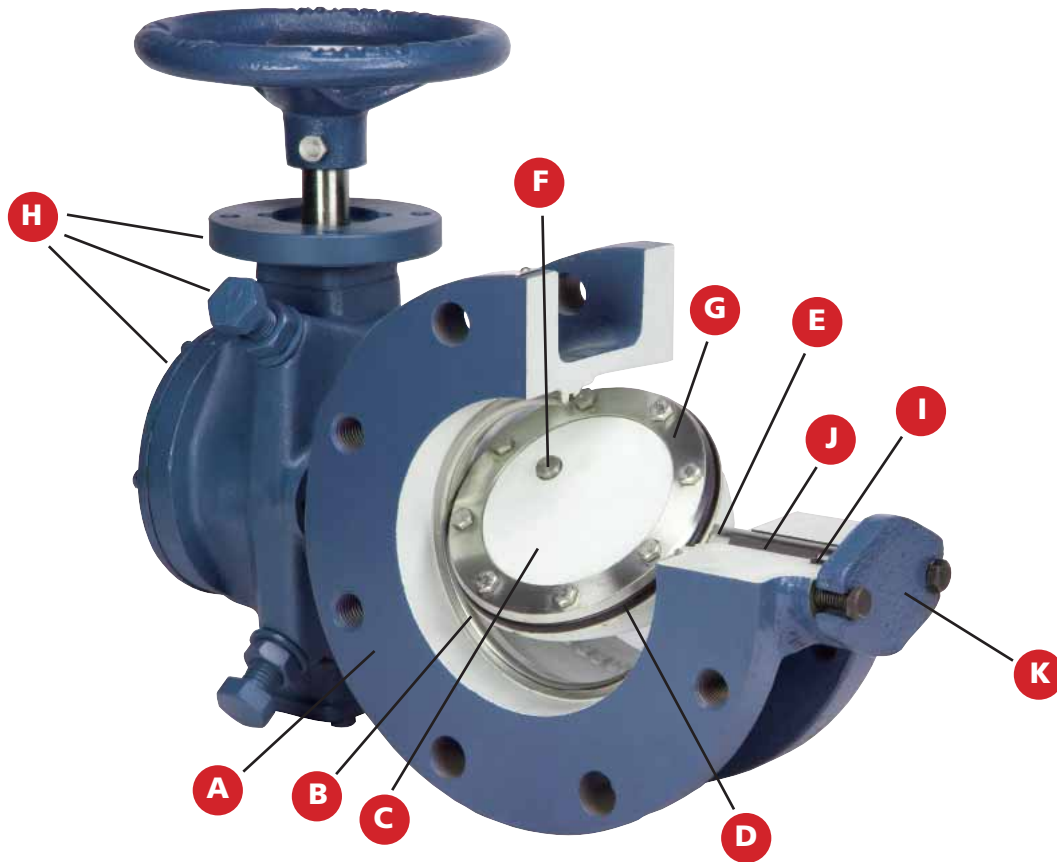

A. Body

Available in Wafer, Lug, Flanged, Mechanical Joint and Flange x Mechanical Joint End Connections in AWWA Classes 150B and 250B.

B. Body Seat

360° uninterrupted body seat with no shaft penetration ensures leak free performance. Type 316 Stainless Steel provides long life and corrosion free mating surface for resilient seat.

C. Ductile Iron Disc

Ductile Iron provides strength and rigidity to withstand dynamic forces from flow and pressure transients. The added strength allows the disc design to have a smaller cross section providing improved headloss characteristics.

D. Resilient Seat

Special formulated elastomers for chemical resistance and long cycle life. The 360° resilient seat is uninterrupted for positive seating.

E. Shaft

Stainless Steel shafts meet AWWA C504 diameter requirements. Through-shafts provided standard on sizes 3" - 24" and available on 30" and larger when specified.

F. Tangential Taper Pins

Stainless Steel Taper Pins with lock nut and o-ring seal utilize tangential forces of the taper pin and lock nut to provide the most secure method available of locking the disc to the shaft.

G. Tri-Loc™ Seat Retention System

With over 40 years of proven dependability the Tri-Loc™ Seating System is easily adjusted and field replaceable. All seat hardware is Type 316 Stainless Steel.

H. Traveling Nut Actuator

The traveling nut design provides characterized closure during the last half of travel. Exclusive externally adjustable stops are rated to 450 ft-lbs of input torque. Standard FA10 motor mounting flange provides ease of automation.

I. Shaft Seal

Shaft seal is a self-adjusting/wear compensating V-Type packing. Packing is easily replaced without removal of the valve from the line.

J. Sleeve Bearings

Low friction bearings are self-lubricating and non-corrosive, for a long, trouble-free life.

K. Thrust Bearing

Factory-set bronze thrust bearing assures proper centering of valve disc. Thrust bearings are field adjustable in sizes 30" and larger.

Proven Design

The American-BFV® is designed, manufactured, and tested to meet all AWWA C504 and C516 requirements including performance tests, leakage tests, and hydrostatic testing. Proof of Design Testing was successfully completed and third-party flow testing was performed at the Utah State Hydraulics Lab, one of the premier testing labs in the world. With thousands of field installations throughout the world, the American-BFV® design has proven dependable since 1971. The valves are certified for use in drinking water in accordance with NSF/ANSI 61 and are NSF/ANSI 372 Certified Lead-Free.

Preferred Features

The American-BFV® provides the features that engineers and users have requested and are included in the AWWA C504 and C516 Butterfly Valve standards. The American-BFV® is designed to provide long life and trouble-free performance. If maintenance becomes necessary, the valve is also designed for easy field service. The shaft seal incorporates V-type packing which is easily replaced in the field without removal from the line. Adjustment of the resilient seat is easily performed with a torque wrench, as compared to epoxy filled seats that require special equipment and materials or bonded seats that cannot be replaced or adjusted in the field.

The unique Tri-Loc™ seat retention system assures seat integrity by securing the seat through three different mechanical methods to assure long-term dependable service, Figure 1. All seat designs provide excellent seating but only the Tri-Loc™ provides ease of adjustment or replacement in the field if ever needed.

The American-BFV® disc is ductile iron in all sizes. The added strength allows the disc design to have a smaller cross section providing improved headloss characteristics. The American-BFV® will withstand flow rates and pressure transients beyond the maximum AWWA pressure rating.

Advanced Technology

Incorporating the latest in valve technology assures a high-quality valve that will provide long service. The design process utilized Solid Modeling and Finite Element Analysis (FEA) of the key structural components. Flow and torque data was derived from flow tests, mathematical models and Computational Fluid Dynamics (CFD). Manufacturing technology uses automated process control in the foundry and ISO 9001 controlled manufacturing processes. Every valve is tested in accordance with AWWA C504 and C516.

Figure 1. Tri-Loc™ Seat Retention System

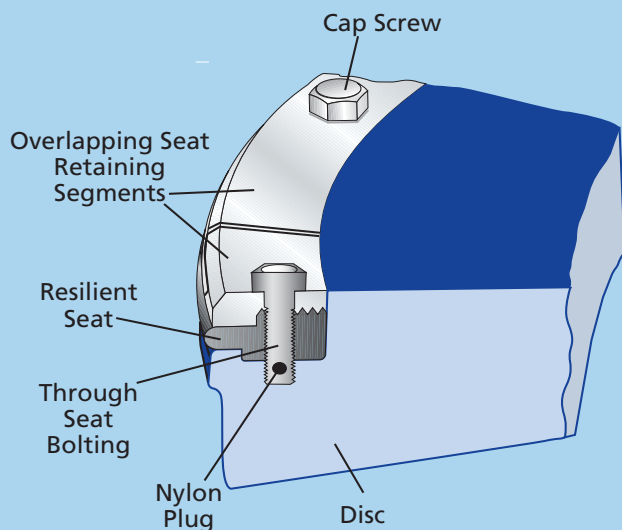

US Patent No: 6,244,567

The Tri-Loc™ seat retention system provides reliable sealing and positive mechanical retention of the valve seat while allowing easy adjustment or replacement in the field.

The seat is secured by three methods: 1) clamp force, 2) through the seat bolting and 3) opposing machined registers in the disc and seat retaining ring. Clamp force is provided by tightening the nylon cap screws. Tightening the screws applies pressure to the serrated seat retaining ring which in turn creates a “clamp force” on the rubber molded seat. These same cap screws provide through-bolting seat retention by passing through precision molded holes in the rubber seat. Finally, molded shoulders in the rubber seat are captured by machined registers in the disc and retention ring preventing outward movement of the seat.

Ratings/Construction

PRESSURE RATINGS

MAXIMUM PRESSURE RATINGS			
SERIES	CONNECTION	AWWA Class	CWP (psig)
2000	ANSI 125# Gray Iron Flange	150B	150
2100	AWWA MJ Gray Iron	150B	150
2200	ANSI 250# Ductile Iron Flange	250B	250
2300	AWWA MJ Ductile Iron	250B	250
2400	ANSI 125# Ductile Iron Flange	250B	250
2500	ANSI 125# Gray Iron Wafer	150B	150
2500L	ANSI 125# Gray Iron Lug	150B	150
2600	ANSI 125# FLG x MJ Gray Iron	150B	150
2700HP*	ANSI 250# FLG Ductile Iron	275C	300

*See Bulletin 2000HP for High Performance Butterfly Valve Information

MATERIALS OF CONSTRUCTION

COMPONENT	STANDARD	OPTIONAL
150B Body 3" - 72"	Cast Iron ASTM A126, Class B	Ductile Iron, Stainless Steel
150B Body 78" - 120"	Ductile Iron ASTM A536 Gr. 65-45-12	Stainless Steel
250B Body 3" - 96"		
Disc	Ductile Iron ASTM A536 Gr. 65-45-12	Stainless Steel
150B Shaft 3" - 72"	Stainless Steel ASTM A276 Type 304	Stainless Steel Type 316, Monel
150B Shaft 78" - 120"	Stainless Steel ASTM A564 Type 630, H1150	Monel
250B Shaft 3" - 84"		
Resilient Seat	Buna-N	EPDM, Viton
Body, Seat and Hardware	Type 316 Stainless Steel	Monel
Shaft Bearings 3" - 24"	Nylatron	Teflon, Bronze
Shaft Bearings 30" and Larger	Teflon-Lined, Fiberglass-Backed	Teflon-Lined, Stainless Steel, Bronze Backed

Headloss Chart

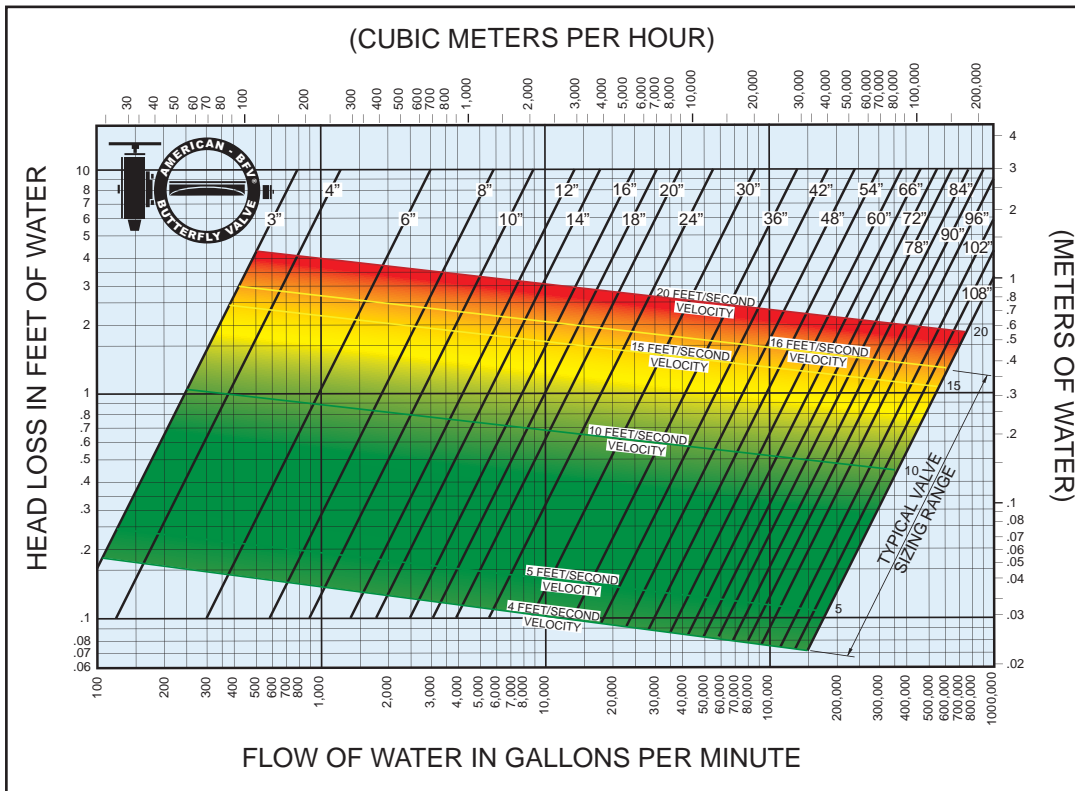

Flow Coefficients

Size	Cv
3	380
4	590
6	1,430
8	2,750
10	4,300
12	6,550
14	8,350
16	11,800
18	15,000
20	18,600
24	27,000
30	42,000
36	61,900
42	87,100
48	114,000
54	144,000
60	180,000
66	221,000
72	266,500
78	316,000
84	366,000
90	420,500
96	478,500
102	540,000
108	605,500
120	744,000

Val-Matic manufactures a wide variety of manual and power actuators that include traveling nut actuators, worm gears, cylinders and motors. In addition Val-Matic valves are easily adaptable for mounting custom actuators such as: vane, spring-return, rack and pinion, electro-hydraulic, air/oil and other specified cylinder or electric motor actuators.

Val-Matic control systems provide reliable power and control of hydraulic actuated butterfly valves. Val-Matic control panels use the highest quality components and provide field adjustable operation of valves. Oil accumulator systems provide hydraulic power for valves even after power failure. Electrical panels provide for remote monitoring of valve operation and alarm conditions.

TRAVELING NUT ACTUATORS



- Manufactured in accordance w/AWWA C504
- Externally Adjustable Stops Rated to 450 Ft-Lbs
- External Indication of Valve Position
- Stainless Steel External Stop Bolts
- Centralizing ACME Thread for High Efficiency
- FA10 Motor Mounting Flange for Ease of Automation

WORM GEAR MANUAL ACTUATORS

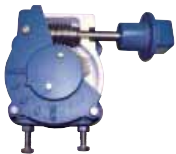

- Manufactured in accordance w/AWWA C504
- Externally Adjustable Mechanical Stops Rated to 300 Ft-Lbs
- External Indication of Valve Position
- Bronze Radial Bearings
- Available for Above Ground, Buried Service and Submerged Applications

AIR, OIL AND WATER CYLINDER ACTUATORS



- Manufactured in accordance w/AWWA C541
- Various Operating Times
- Available with Non-Intrusive Enclosure
- Electric Power - 3PH, 1PH and DC Motors
- Adjustable Limit and Torque Switches
- Open/Close, Modulating and Throttling

ELECTRIC MOTOR ACTUATORS



- Manufactured in accordance w/AWWA C542
- Cylinder Bore Sizes Up to 24"
- Suitable for Air, Oil and Water Supply Media Up to 150 psig
- Available with Declutchable Hand Wheel Overrides
- Cylinder Available in All Stainless Steel and Non-Metallic Construction

CONTROL SYSTEMS

OIL ACCUMULATOR SYSTEMS



- Size Range: 80-400 Gallon Capacity
- Pressure Range: Up to 125 PSI
- Equipped with Electrical Control Panels
- Compact Skid Design

HYDRAULIC CONTROL PANELS



- NEMA 4X Waterproof and Corrosion Resistant Enclosures
- Supply Line with Isolation Valve and Pressure Gauge
- Corrosion Resistant Piping
- Reliable Brass Solenoid Valves and Multi-Turn Flow Control Valves

ELECTRIC CONTROL PANELS



- NEMA 4X Waterproof and Corrosion Resistant Enclosures
- Plug-In Control Relays
- Emergency Stop Alarm Circuit
- Heavy-Duty Switches and Transformer Pilot Lights

Installation Dimensions

Flanged End Connection

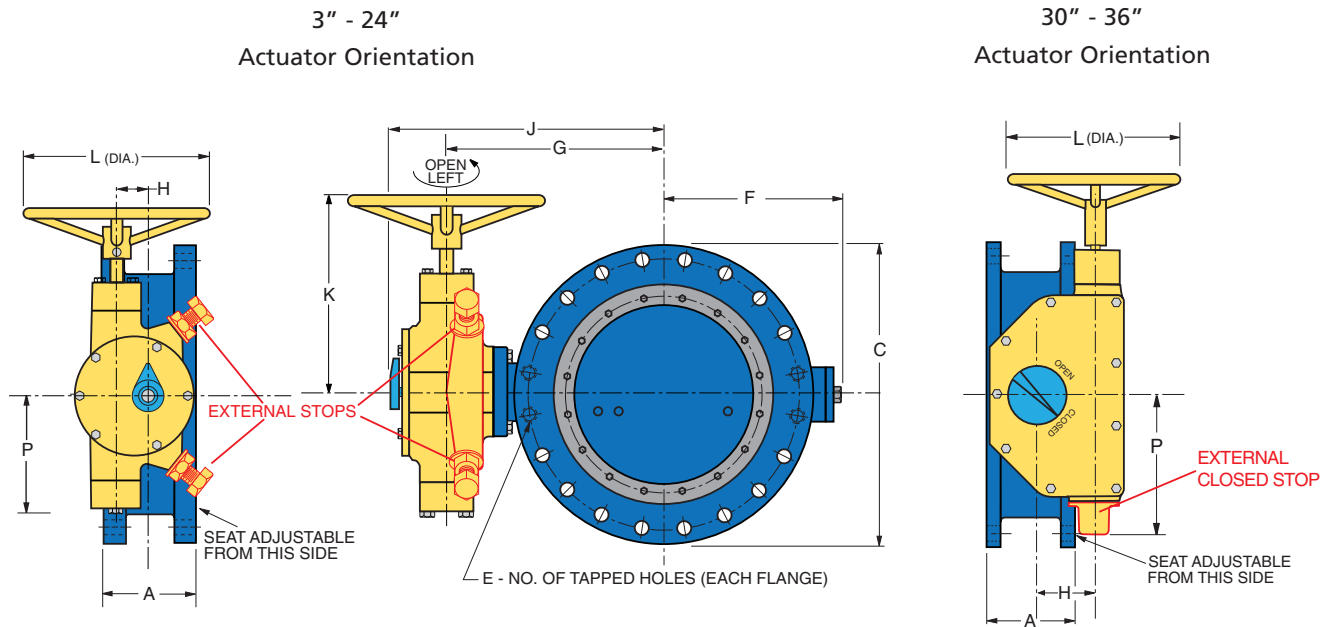

Note: End Flanges Conform to ANSI B16.1 Class 125 or 250

Dimensions in Inches

Valve Size	Pressure Class	A	C	E	F	G	H	J	K	L	P	Turns to Open	Actuator Size	Weight
3	150B	5.00	7.50	4	6.00	7.44	1.50	10.12	9.38	8	5.65	15	LS-1A	63
	250B	5.62	8.25	8										71
4	150B	5.00	9.00	0	6.00	7.44	1.50	10.12	9.38	8	5.65	15	LS-1A	71
	250B	5.62	10.00											90
6	150B	5.00	11.00	4	7.00	8.12	1.50	10.81	9.38	8	5.65	15	LS-1.2A	92
	250B	5.88	12.50			8.44		11.06						128
8	150B	6.00	13.50	0	8.00	9.12	1.50	11.75	9.38	8	5.65	15	LS-1.2A	128
	250B	7.00	15.00			4		9.69						12.31
10	150B	8.00	16.00	0	10.00	11.50	2.00	14.31	10.38	12	6.50	20	LS-2A	194
	250B	9.38	17.50											273
12	150B	8.00	19.00	0	11.06	12.56	2.00	15.38	10.38	16	6.50	20	LS-2A	270
	250B	9.50	20.50			12.81		15.63						376
14	150B	8.00	21.00	0	13.50	15.62	3.50	19.19	19.12	24	9.15	35	LS-3A	383
	250B	9.50	23.00											4
16	150B	8.00	23.50	0	14.62	16.69	3.50	20.19	19.12	24	9.15	35	LS-3A	477
	250B	9.62	25.50											4
18	150B	8.00	25.00	4	15.50	17.94	5.00	21.50	20.88	24	10.80	50	LS-4A	636
	250B	9.62	28.00											866
20	150B	8.00	27.50	4	17.50	19.94	5.00	23.50	20.88	24	10.80	50	LS-4A	746
	250B	9.62	30.50											1024
24	150B	8.00	32.00	4	20.50	22.94	5.00	26.50	20.88	24	10.80	50	LS-4A	1088
	250B	9.75	36.00						22.38	30				1508
30	150B	12.00	38.75	4	27.40	29.40	8.50	35.20	29.56	24.00	17.80	60	LS-5A	2370
	250B	13.75	43.00											2713
36	150B	12.00	46.00	4	29.50	32.12	8.50	37.94	29.56	24.00	17.80	60	LS-5A	3425
	250B	14.00	50.00											3980

Installation Dimensions Flanged End Connection

42" - 90"
Actuator Orientation

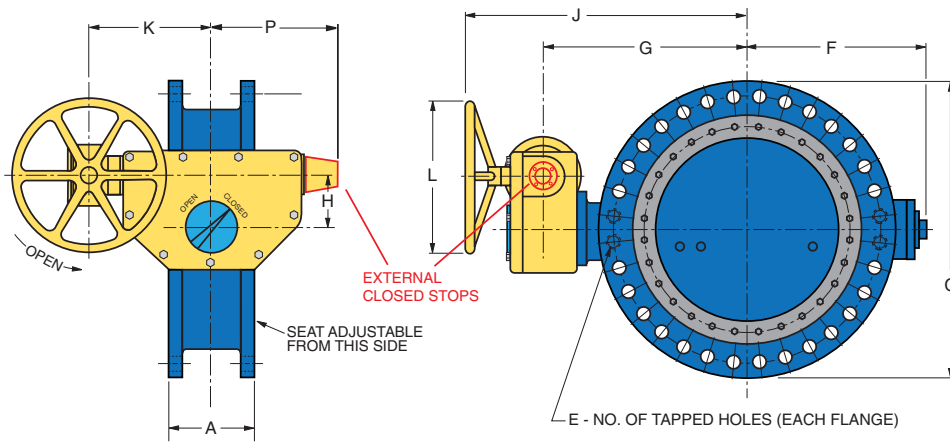

96" - 120"
Actuator Orientation

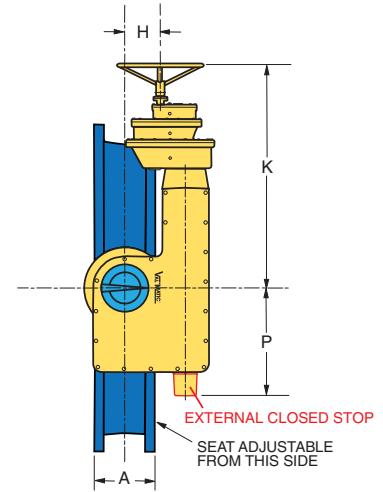

Note: End Flanges Conform to ANSI B16.1 Class 125 or 250

American-BFV®
Butterfly Valves

Dimensions in Inches														
Valve Size	Pressure Class	A	C	E	F	G	H	J	K	L	P	Turns to Open	Actuator Size	Weight
42	150B	12.00	53.00	4	35.25	35.88	8.50	49.50	20.13	24.00	17.75	178	LS-5.2A	4559
	250B	14.12	57.00											5489
48	150B	15.00	59.50	4	39.31	41.44	10.50	57.75	24.94	24.00	21.88	276	LS-6A	6950
	250B	17.50	65.00											8510
54	150B	15.00	66.25	8	44.25	45.44	10.50	61.75	24.94	24.00	21.88	276	LS-6A	9280
	250B		66.25											9280
60	150B	15.00	73.00	8	48.25	51.88	10.50	70.12	24.94	24.00	21.88	276	LS-6A	12900
	250B		73.00											12900
66	150B	18.00	80.00	8	53.31	58.12	10.50	76.38	24.94	24.00	21.88	276	LS-6A	14840
	250B		80.00											14840
72	150B	18.00	86.50	8	59.00	61.00	14.00	79.25	32.25	24.00	28.75	547	LS-7A	17840
	250B		86.50											17840
78	150B	18.00	93.00	8	54.50	73.63	14.00	94.38	32.25	24.00	28.75	547	LS-7.3A	14040
84	150B	19.00	99.75	8	58.75	76.25	14.00	98.50	32.25	30.00	28.75	547	LS-7.2A	16440
	250B	24.00	99.75											8
90	150B	20.00	106.50	8	62.88	82.50	14.00	105.75	32.25	36.00	28.75	547	LS-7A	19740
96	150B	21.00	113.25	8	68.50	73.30	12.30	88.30	54.20	30.00	37.30	1750	LSG-8A	27400
102	150B	24.00	120.00	8	71.70	77.40	12.30	92.40	54.20	30.00	37.30	1750	LSG-8A	31100
108	150B	24.00	126.75	8	75.38	82.30	12.30	97.30	55.70	30.00	37.30	1750	LSG-8A	35000
120	150B	26.00	140.25	8	83.30	89.20	12.30	104.20	57.10	30.00	37.30	1750	LSG-8A	47400

Installation Dimensions

Mechanical Joint End Connection

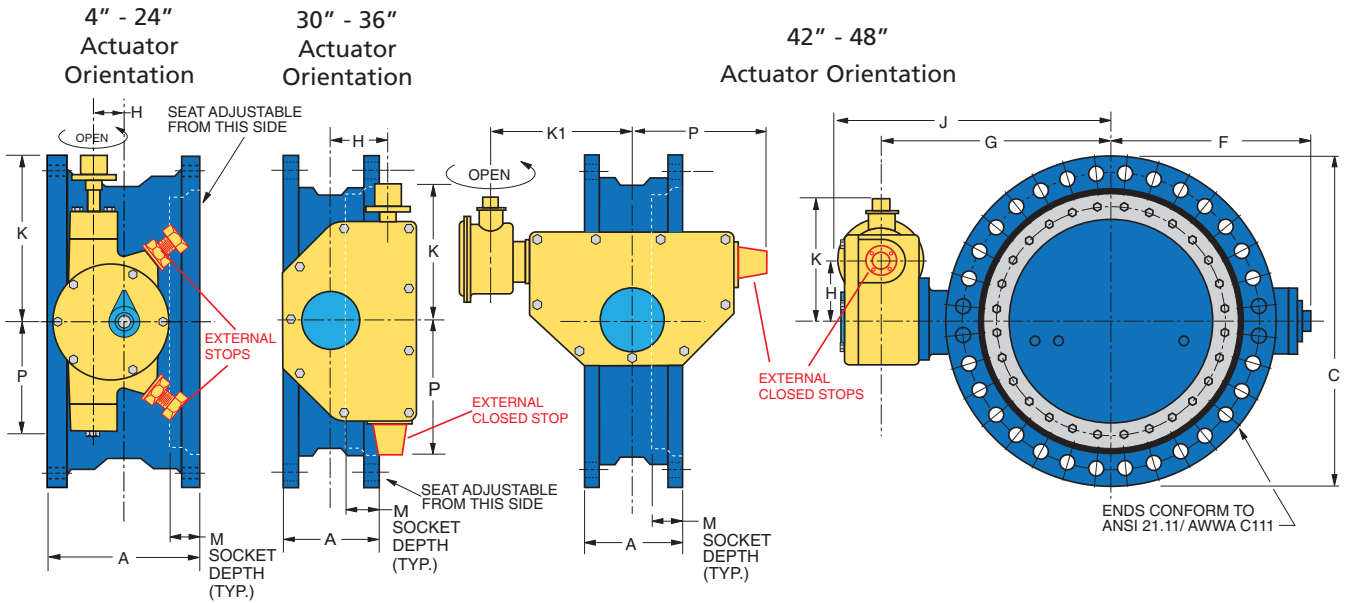

American-BFV®
Butterfly Valves

Dimensions in Inches

Valve Size	Pressure Class	A	C	F	G	H	J	K	K1	M	P	Actuator Size	Weight
4	150B	7.50	9.13	6.00	7.46	1.50	9.96	7.83	-	2.50	5.65	LS-1A	90
	250B												
6	150B	8.00	11.13	7.03	8.15	1.50	10.65	7.83	-	2.50	5.65	LS-1.2A	135
	250B												
8	150B	8.25	13.38	8.00	9.13	1.50	11.63	7.83	-	2.50	5.65	LS-1.2A	190
	250B												
10	150B	8.88	15.69	10.00	11.50	2.00	14.19	8.71	-	2.50	6.50	LS-2A	265
	250B												
12	150B	10.00	17.94	11.06	12.56	2.00	15.25	8.71	-	2.50	6.50	LS-2A	345
	250B												
14	150B	13.00	20.31	13.50	15.65	3.50	19.03	12.06	-	3.50	9.15	LS-3A	560
	250B												
16	150B	14.00	22.56	14.63	16.69	3.50	20.06	12.06	-	3.50	9.15	LS-3A	670
	250B												
18	150B	14.13	24.81	15.50	17.94	5.00	21.38	13.81	-	3.50	10.80	LS-4A	875
	250B												
20	150B	14.00	27.13	17.50	19.94	5.00	23.38	13.81	-	3.50	10.80	LS-4A	1070
	250B												
24	150B	15.63	31.56	20.50	22.94	5.00	26.38	13.81	-	3.50	10.80	LS-4A	1395
	250B												
30	150B	18.13	39.13	27.38	29.18	8.50	35.00	19.50	-	4.00	17.75	LS-5A	2480
	250B												
36	150B	19.25	46.00	29.50	31.88	8.50	37.75	19.50	-	4.00	17.75	LS-5A	3775
	250B												
42	150B	19.75	53.13	35.25	35.88	8.50	41.75	17.50	19.50	4.00	17.75	LS-5.2A	5800
	250B												
48	150B	21.31	60.00	39.31	41.50	10.50	50.25	22.25	24.88	4.00	21.88	LS-6A	8600
	250B												

Installation Dimensions

Flange X Mechanical Joint End Connection

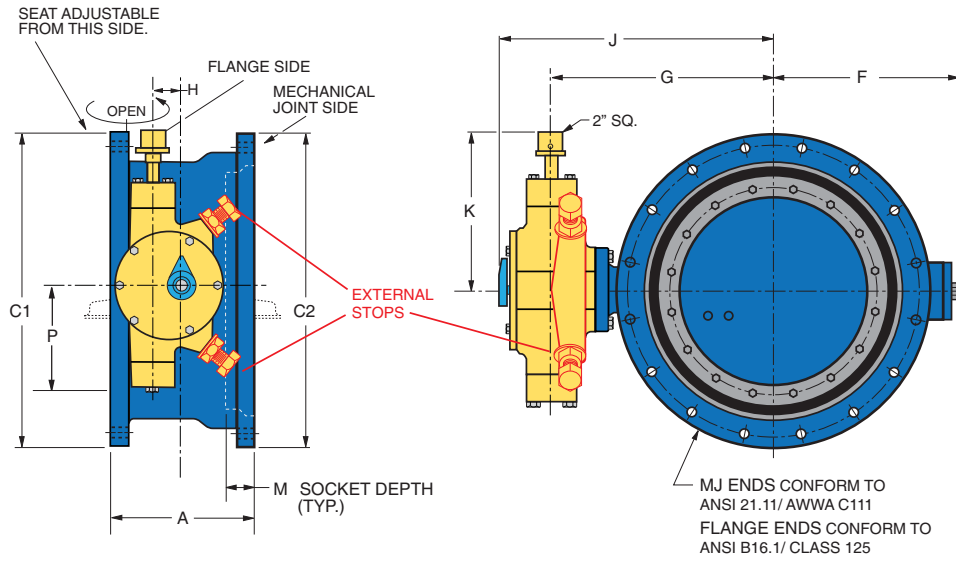

Dimensions in Inches													
Valve Size	Pressure Class	A	C1	C2	F	G	H	J	K	M	P	Actuator Size	Weight
6	150B	6.75	11.00	11.12	7.03	8.15	1.50	10.65	7.83	2.50	5.65	LS-1.2A	110
8	150B	7.50	13.50	13.38	8.00	9.13	1.50	11.63	7.83	2.50	5.65	LS-1.2A	165
12	150B	8.62	19.00	17.94	11.06	12.56	2.00	15.25	8.71	2.50	6.50	LS-2A	300
16	150B	10.00	23.50	22.56	14.62	16.69	3.50	20.06	12.36	3.50	9.15	LS-3A	600

American-BFV®
Butterfly Valves

Wafer Body Connection

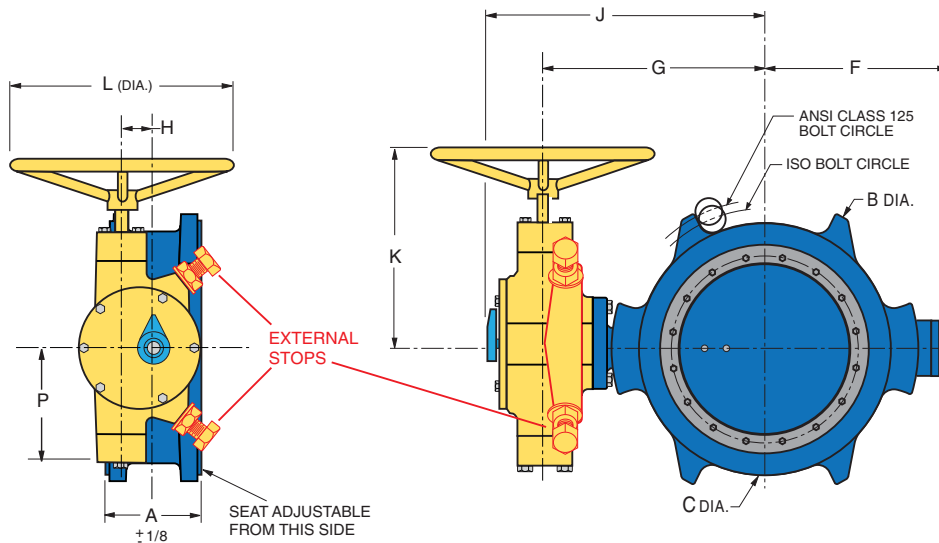

Dimensions in Inches														
Valve Size	Pressure Class	A	B	C	F	G	H	J	K	L	P	Turns to Open	Actuator Size	Weight
4	150B	2.25	7.88	6.41	6.00	7.44	1.50	10.13	9.38	8	5.65	15	LS-1A	48
6	150B	2.81	9.70	8.59	7.00	8.13	1.50	10.81	9.38	8	5.65	15	LS-1.2A	64
8	150B	2.94	12.50	10.75	8.00	9.13	1.50	11.75	9.38	8	5.65	15	LS-1.2A	70
10	150B	3.13	14.75	12.94	10.00	11.50	2.00	14.31	10.38	12	6.50	20	LS-2A	110
12	150B	3.38	17.38	14.88	11.06	12.56	2.00	15.38	10.38	16	6.50	20	LS-2A	125

Installation Dimensions

Lug Body Connection

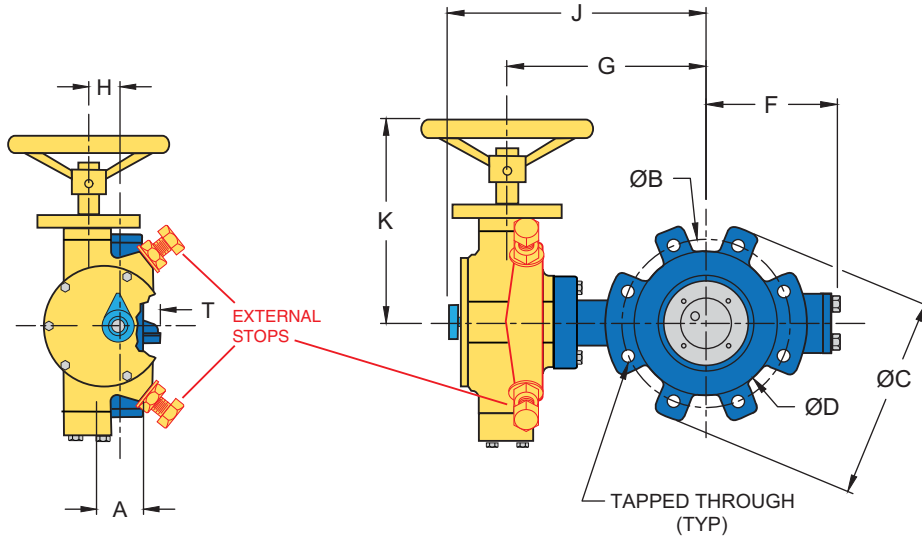

Dimensions in Inches

Valve Size	Pressure Class	A	B	C	D	F	G	H	J	K	T	Turns to Open	Actuator Size	Wt
4	150B	2.25	7.50	9.00	6.41	6.00	8.90	1.50	11.60	7.83	0.80	15	LS-1A	69
6	150B	2.81	9.50	11.00	8.59	7.00	9.90	1.50	12.60	7.83	1.60	15	LS-1.2A	89
8	150B	2.93	11.75	13.50	10.75	8.00	11.10	1.50	13.80	7.83	2.50	15	LS-1.2A	123
10	150B	3.23	14.25	16.00	12.94	10.00	12.80	2.00	15.60	8.71	3.30	20	LS-2A	175
12	150B	3.55	17.00	19.00	14.88	11.10	14.30	2.00	17.10	8.71	4.20	20	LS-2A	253

Accessories

Space limitations and application specifics often require special accessories. In addition to those shown below, Val-Matic offers a wide range of accessories to meet your application requirements. Please consult factory for assistance.

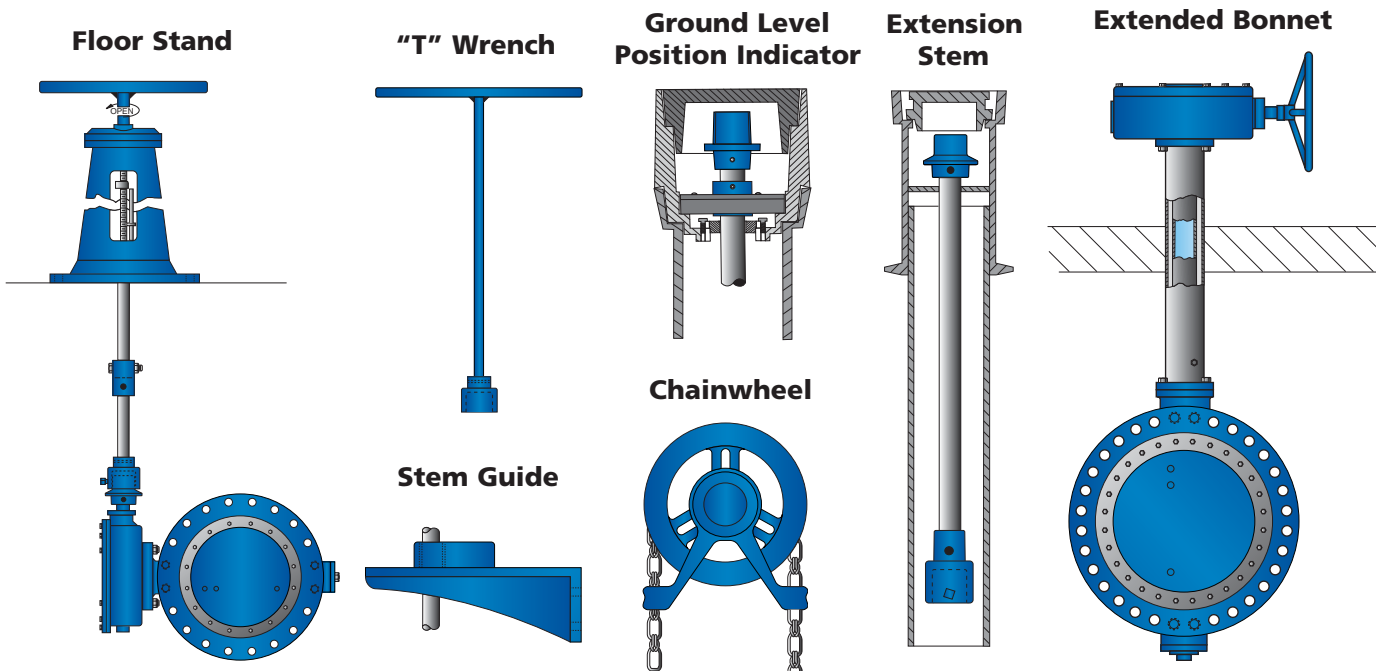

SCOPE

- 1.1 This specification covers the design, manufacture, and testing of AWWA Class 150B (3"-144") and AWWA Class 250B (3"-96") butterfly valves.

STANDARDS AND APPROVALS

- 2.1 The valves shall be designed, manufactured and tested in accordance with American Water Works Association Standard ANSI/AWWA C504 and C516.
- 2.2 The valves shall be certified to NSF/ANSI 61 Drinking Water System Components - Health Effects and certified to be Lead-Free in accordance with NSF/ANSI 372.
- 2.3 Manufacturer shall have a quality management system that is certified to ISO 9001 by an accredited, certifying body.

CONNECTIONS

- 3.1 Flanged end connections shall fully conform with ANSI B16.1 for Class 125, Class 250 iron flanges, or AWWA C207 Class D. Both 125 and 250 flanges shall be flat faced.
- 3.2 Mechanical Joint end connections shall fully conform with ANSI/AWWA C111/A21.11.
- 3.3 Wafer end connections shall be designed for installation between ANSI B16.1 Class 125 iron flanges or between ISO 7005-2 PN10 or PN16 flanges.

DESIGN

- 4.1 The valve shafts shall be of the through-type for sizes 3"-24". 30" and larger shall be of the stub type design. Shafts shall be locked to the disc by O-ring sealed taper pins retained with stainless steel nuts. Through-type shafts shall be supplied on 30" and larger valves when specified.
- 4.2 The valve discs shall be of the solid type without external ribs or vanes to obstruct flow.
- 4.3 Resilient seats shall be located on the valve disc and shall provide a 360° continuous, uninterrupted seating surface. Seats shall be mechanically retained with a stainless steel retaining ring and stainless steel cap screws which shall pass through both the resilient seat and the retaining ring. The retaining ring shall be continuous or investment cast with overlapping sections, serrated grooves, and shoulders providing a Tri-Loc® system. The resilient seat's mating surface shall be to a 360° continuous, uninterrupted stainless steel body seat ring. Resilient seats shall be field adjustable and replaceable without removing the valve from the line and shall not require epoxy, syringes, needles or pressure vessels to replace or adjust.
- 4.4 The sleeve bearings shall be provided in the valve hubs and shall be self-lubricating nylatron or teflon lined, fiberglass backed.
- 4.5 The thrust bearings shall be provided and shall be adjustable on valves 30" and larger.
- 4.6 The shaft seals shall be of the V-type and shall be replaceable without removal of the valve from the line or the shaft from the valve.

MATERIALS

- 5.1 Body: Class 150B valve bodies shall be ASTM A126, Class B gray iron or ASTM A536 Grade 65-45-12 ductile iron. Class 250B valve bodies shall be ASTM A536 Grade 65-45-12 ductile iron.
- 5.2 Disc: Valve disc shall be ASTM A536 Grade 65-45-12 ductile iron.
- 5.3 Shafts: Shafts shall be ASTM A276 type 304, or ASTM A564, Type 630 Stainless Steel.

- 5.4 Seat: Resilient seat shall be Buna-N and mate to a Type 316 Stainless Steel body seat ring.
- 5.5 Hardware: All seat retaining hardware shall be Type 316 stainless steel.

ACTUATION

- 6.1 Manual, electric or cylinder actuation shall be provided as specified.
- 6.2 Manual actuators shall be of the traveling nut design with characterized closure per AWWA C504 and equipped with externally adjustable closed position stops capable of withstanding 450 ft-lbs. Actuators shall be lubricated with EP-2 grease and fully enclosed in an iron housing sealed against the entry of water. Buried service actuators shall be packed with grease and sealed for temporary submergence to 20 feet of water. Exposed input shafts shall be electroless nickel plated or stainless steel.
- 6.3 Cylinder actuators shall be traveling nut design with characterized closure sized to position the valve with an air, water or oil supply pressure of 80-150 psi and built in accordance with AWWA C541. The rotating mechanism will consist of a lever and traveling nut directly connected to the cylinder rod. The cylinder rod, heads and barrel shall be constructed of stainless steel or non-metallic material for water service. Rod and piston seals shall be of the self-adjustable, wear-compensating type. The piston shall be one-piece with a wear strip.
- 6.4 Motor actuators shall be furnished in accordance with AWWA C542 for Power Actuators and factory tested on the production valve. The motor unit shall be mounted to a self-locking traveling nut actuator with characterized closure and externally adjustable closed stop. The motor actuator assembly shall be designed for open/close service with a minimum operating time of 60 sec. The motor unit shall be furnished with a position indicator, independently adjustable, 15-amp limit switches, and adjustable torque sensors to protect the valve indicator. A handwheel with a declutch lever shall be provided so that the handwheel does not rotate during electrical operation. Motors shall be sized with a 1.5 safety factor and a power supply of 230/460V, three phase, 60 Hz AC. Electrical operation shall include Local-Off-Remote selector switch, local Open/Close push buttons and position indication lamps.

OPTIONS

- 7.1 Optional body material is ASTM A536, Grade 65-45-12 ductile iron.
- 7.2 Optional shaft material is ASTM A276, Type 316 stainless steel.
- 7.3 Optional manual actuator for submerged service shall be packed with grease and sealed for continuous submergence to 30 feet of water. All fasteners shall be stainless steel and all the exposed input shafts shall be electroless nickel plated or stainless steel.
- 7.4 Optional resilient seat material is EPDM.

MANUFACTURE

- 8.1 The valve exteriors for above ground service shall be coated with a universal, alkyd primer. Valve exteriors for buried service shall be coated with an epoxy coating. Valve interiors shall be coated with an NSF/ANSI 61 epoxy coating approved for potable water. Fusion bonded epoxy shall be supplied on the exterior and interior when specified.
- 8.2 Butterfly Valves shall be Val-Matic® Series 2000 as manufactured by Val-Matic® Valve & Mfg. Corporation, Elmhurst, IL. USA or approved equal.



*American-BFV® Butterfly Valve
with Mechanical Joint Connections*



American-BFV® Butterfly Valve with Extended Bonnet

VAL-MATIC®



Double Offset
High Performance
Waterworks
Butterfly Valves



NSF/ANSI 61 & 372 Certified

Proven Design

Ductile Iron Construction • 17-4 Stainless Steel Shaft • Double Offset Design

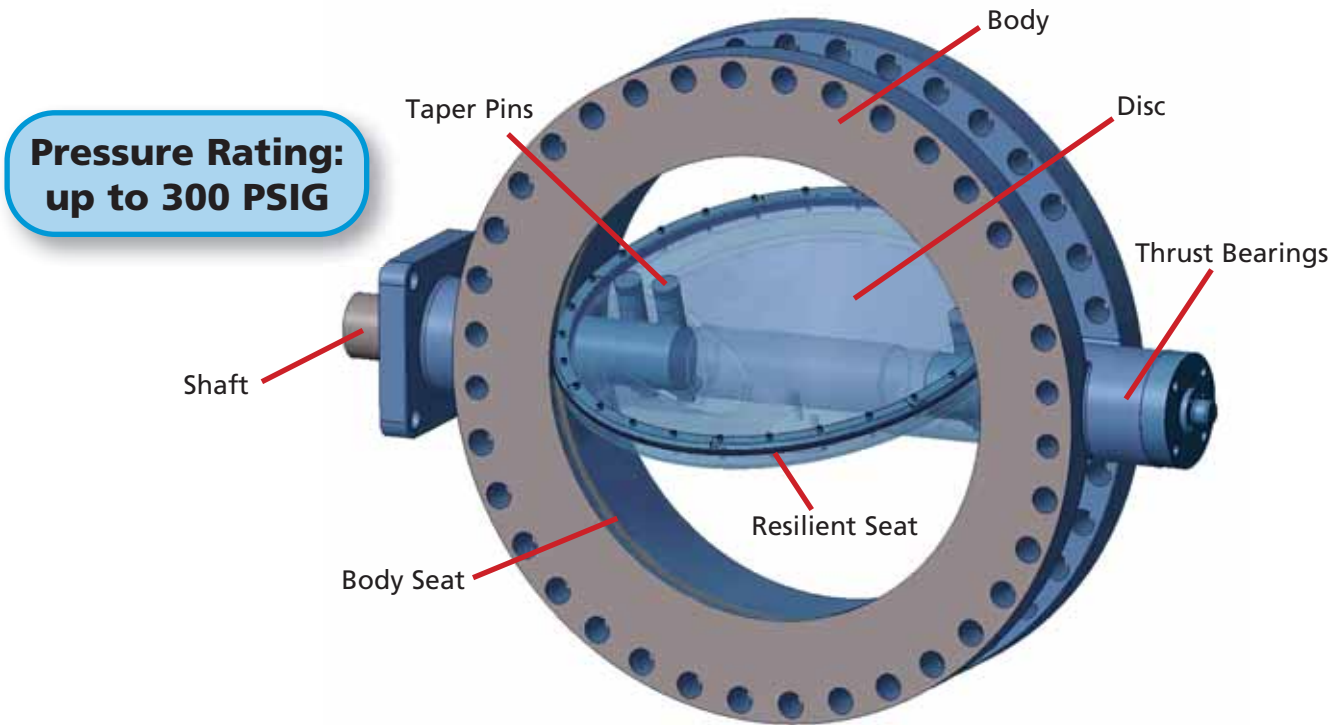

**Pressure Rating:
up to 300 PSIG**

American-BFV®
Butterfly Valves

Preferred Features

Size and End Connections

Available in flanged and MJ end connections through 48in. Contact factory for larger sizes.

Pressure Class

Meets or exceeds AWWA Class 275C for bi-directional service to line velocities of 24 ft./sec.

Shaft

High strength 17-4 PH stainless steel shafts positively retained to prevent ejection.

Thrust Bearings

Factory-set bronze thrust bearing assures proper centering of valve disc.

Shaft Seal

Self-adjusting/wear compensating V-Type packing with mechanically retained packing gland.

Body Seat

High integrity precision welded nickel seat.

Reinforced Resilient Seat on Disc

Specially formulated elastomers that are reinforced and capable of handling localized velocities of over 200 ft./sec.

Actuation

AWWA traveling nut design provides characterized closure. Worm gear, electric motor, or cylinder actuation available.

Shaft Bearings

Self-lubricated teflon-lined, fiberglass-backed bearings provide low friction service without grease lubrication.

Tangential Taper Pins

Stainless Steel Taper Pins with lock nut and o-ring seal utilize tangential forces of the taper pin and lock nut to provide the most secure method available of locking the disc to the shaft.

Coating

Fusion Bonded Epoxy (FBE) is the standard on the interior and exterior of the valve. The FBE is NSF/ANSI 61 certified.

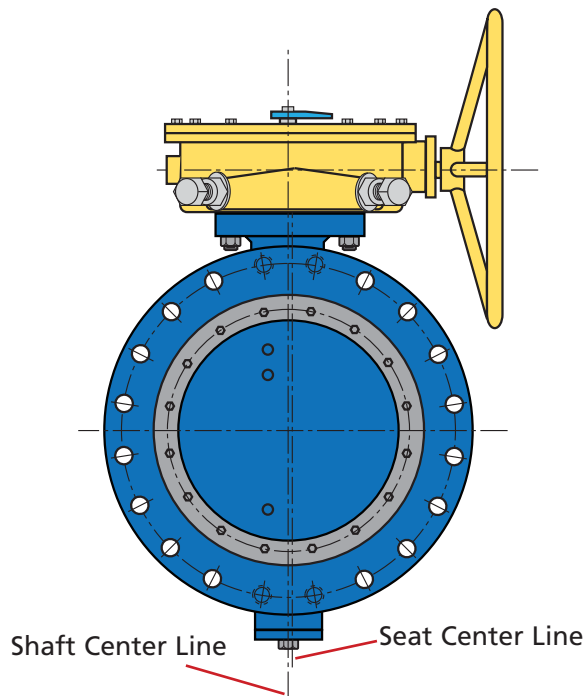

Double Offset Design - "Cam-action" from the additional offset allows the seat to compress only when the disc is fully rotated into the valve body. The additional offset prevents compression set of the seat, reduces seat strain and is ideal for applications where the valve is normally left open.

Precision Welded Body Seat – High alloy corrosion resistant and micro polished seating surface provides corrosion free mating surface; precision welded body seat design adds durability for high pressure applications and ensures a long lasting seal.

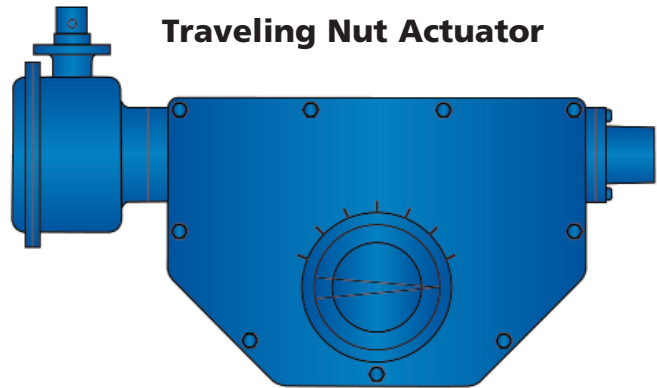

Traveling Nut Actuation – The traveling nut actuator provides characterized closure which allows the valve to slowly close during the last half of travel to reduce pipeline surges. These actuators also have the exclusive feature of externally adjustable stops.

Tri-Loc™ Seat

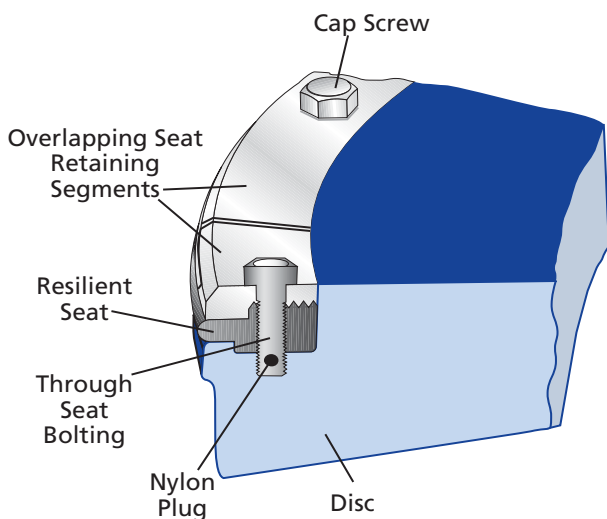

US Patent No: 6,244,567

The Tri-Loc™ seat retention system provides reliable sealing and positive mechanical retention of the valve seat while allowing easy adjustment or replacement in the field. The Tri-Loc™ overlapping seat segments provide for easy replacement and prevent scalloping of the resilient seat surface.

The seat is secured by three methods: 1) clamp force, 2) through the seat bolting and 3) opposing machined registers in the disc and seat retaining ring. Clamp force is provided by tightening the self-locking cap screws. Tightening the screws applies pressure to the serrated seat retaining ring which in turn creates a "clamp force" on the resilient molded seat. These same cap screws provide through-bolting seat retention by passing through precision molded holes in the resilient seat. Finally, molded shoulders in the resilient seat are captured by machined registers in the disc and retention ring preventing outward movement of the seat.

Specification

Scope

1.1 This specification covers the design, manufacture, and testing of flanged and mechanical joint 4 in. (100 mm) through 48 in. (1200 mm) high performance, double-offset, resilient-seated butterfly valves suitable for water or raw water service with pressures up to 300 psig (2068 kPa).

Standards and Approvals

- 2.1 The valves shall be designed, manufactured and tested in accordance with American Water Works Association Standards.
- 2.2 The valves used in potable water service shall be certified to NSF/ANSI 61, Drinking Water System Components - Health Effects, and certified to be Lead-Free in accordance with NSF/ANSI 372.
- 2.3 Manufacturer shall have a quality management system that is certified to ISO 9001 by an accredited, certifying body.

Connections

- 3.1 Flanged end connections shall have flange drilling in accordance with ANSI B16.42 for Class 300 or 150 iron flanges, or AWWA C207 Class F.
- 3.2 Mechanical Joint end connections shall fully conform with ANSI/AWWA C111/A21.11.

Design

- 4.1 The valve shall be of double offset design and provide seat clearance when fully open.
- 4.2 Resilient seats shall be located on the valve disc and shall be mechanically retained with overlapping investment cast stainless steel segments and stainless steel Nylok® cap screws which shall pass through the resilient seat. Resilient seats shall be field adjustable and replaceable and shall not require epoxy, syringes, needles or pressure vessels to replace or adjust.
- 4.3 Body seat shall be a welded corrosion resistant nickel alloy.
- 4.4 The shafts shall be rigidly secured to the disc with tangential tapered pins and nuts.
- 4.5 Sleeve bearings shall be provided in the valve body hubs and shall be self-lubricated, teflon-lined, and fiberglass-backed.
- 4.6 Shaft seals shall be of the V-type secured with a bolted gland plate to allow actuator servicing.

Materials

- 5.1 Valve body and disc shall be cast ASTM A536 Grade 65-45-12 ductile iron.
- 5.2 Shafts shall be turned and polished ASTM A564, 17-4 PH Stainless Steel.
- 5.3 Resilient seats shall be reinforced Buna-N.
- 5.4 All seat retaining hardware shall be Type 316 stainless steel.
- 5.5 The valve shall be coated internally and externally with fusion bonded epoxy.

Actuation

- 6.1 Manual, electric or cylinder actuation shall be provided as specified.
- 6.2 Manual actuators shall be of the traveling nut design with characterized closure per AWWA C504 and equipped with externally adjustable closed position stops capable of withstanding 450 ft-lbs.

Options

- 7.1 When specified, the valve seats shall be welded type 316 stainless steel.
- 7.2 When specified, the valve shall be baked glass or HVOF stainless-steel lined.

Manufacture

- 8.1 Valve shall be Val-Matic Series 2000HP or pre-approved equal.



Double Offset High Performance Waterworks Butterfly Valve

*American-BFV® Butterfly Valve
on Test Stand*



American-BFV® Butterfly Valve

VAL-MATIC®



Cam-Centric®
Standard Port
Plug Valves



Meets AWWA C517
NSF/ANSI 61 & 372 Certified

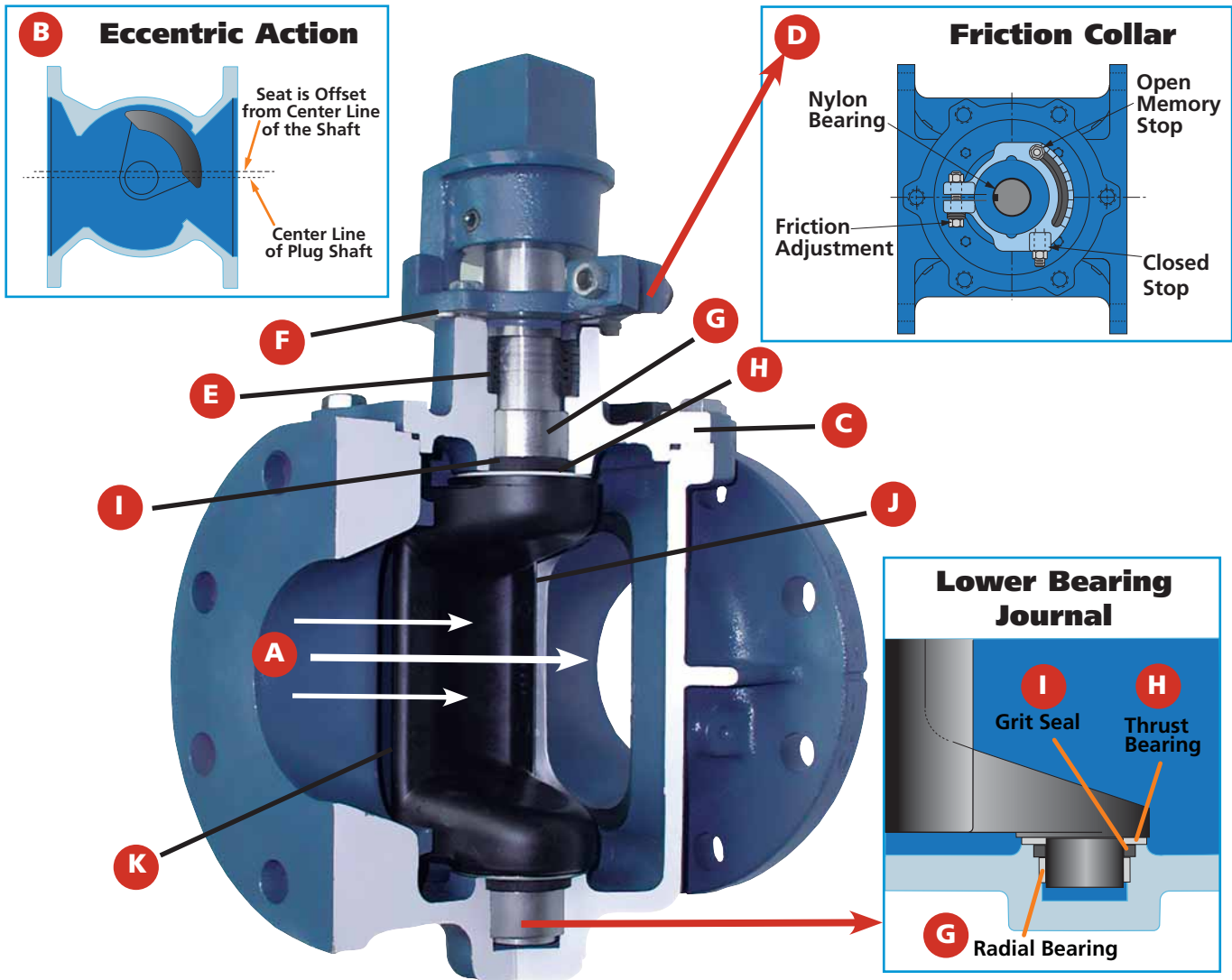

A. Non-Clog Design

The flow area and smooth stream-line contouring allows passage of large solids to prevent potential clogging and provide low head-loss.

B. Eccentric Action

Provides positive shut off in both directions with wear resistant action and low torque.

C. Full Top Access Cover

Provides accessibility for inspection without removal of the valve from the line.

D. Friction Collar with Memory Stop

Secures valve plug in any position and includes a nylon bearing for ease of operation.

E. V-Type Packing

Field adjustable and replaceable without removal of worm gear or motor actuators.

F. Removable POP™ Shims

Packing Overload Protection Shims protect packing by preventing overload during field adjustment.

G. Radial Bearings

Heavy Duty, T316 Stainless Steel, Permanently Lubricated.

H. Thrust Bearing

Upper: PTFE - Provides ease of actuation during operating conditions.

Lower: Stainless Steel - Prevents wear to plug and Grit-Guard.

I. Grit-Guard™ Shaft Seal

The *Val-Matic Exclusive* Grit-Guard™ shaft seal extends packing and bearing life by reducing wear and infiltration of grit.

J. Seat

The robotic pulsed-arc welded 95% nickel raised seat is corrosion and wear resistant.

K. Plug

Fully rubber encapsulated molded plug eliminates exposed surfaces for maximum resistance to corrosion and wear.

Proven Design

With installations worldwide, the Val-Matic Cam-Centric® Plug Valve has proven itself as the preferred valve for wastewater, industrial waste and process applications. The Cam-Centric® Plug Valve is a ¼ turn eccentric plug valve allowing cost effective, low torque actuation for pump control, shut-off and throttling service. The valve's eccentric action rotates the plug in and out of the seated position with minimal contact, thereby preventing high torque and wear to the valve seat and plug. The combination of the eccentric action, stainless steel bearings, Grit-Guard™ seals and heavy duty nickel seat assures long life with minimal maintenance.

Preferred Features

The Cam-Centric® Plug Valve features a shaft sealing system that utilizes V-Type packing, a packing follower and a Grit-Guard™ seal for ease of maintenance and to reduce wear. The Grit-Guard™ seals reduce wear by preventing grit and media from reaching the bearings and packing to prevent plug lock up. The seals are standard in both the upper and lower journals (Figures 1 & 2). To prevent the packing from being over tightened, the shaft seal incorporates POP™ (Packing Overload Protection) Shims. The packing is easily adjusted by removing the POP™ shims as necessary utilizing the pull tab feature (Figure 1). Adjustment or replacement of the V-Type packing can be done without removal of the gear, motor or cylinder actuator.

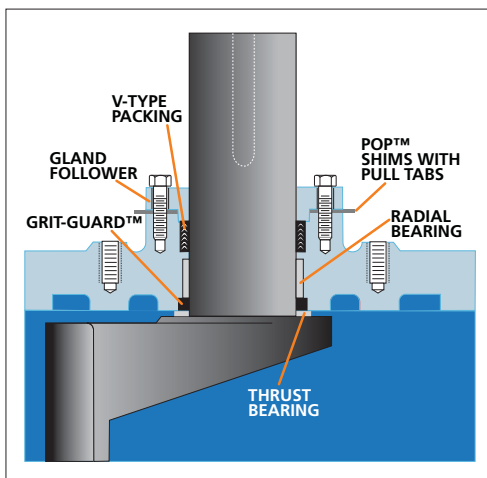

Figure 1. Upper Bearing Journal

The Cam-Centric® bearing package consists of permanently lubricated, T316 stainless steel radial bearings in both the upper and lower journals. The upper thrust bearing is made of PTFE and the lower thrust bearing is T316 stainless steel.

The Cam-Centric® Plug Valve utilizes a contoured and totally encapsulated molded plug to reduce corrosion and wear in severe abrasive applications. Its ductile iron construction provides strength and rigidity to withstand dynamic forces from flow and pressure.

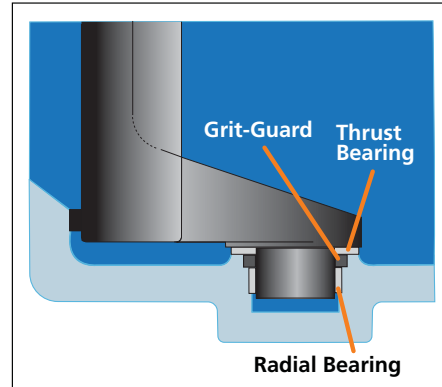

Figure 2. Lower Bearing Journal

The valve seat is a welded overlay of 95% pure nickel applied directly to the body on a machined surface using a state-of-the-art robotic welding system for a consistent, high quality weld (Figure 3).



Figure 3. Robotic welding of nickel seat

Advanced Technology

Incorporating the latest in valve technology assures a high-quality valve that will provide long service. The design process utilized solid Modeling and Finite Element Analysis (FEA) of the key structural components. Flow and torque data was derived from flow tests, mathematical models and Computational Fluid Dynamics (CFD). Manufacturing technology uses automated process control in the foundry and ISO 9001 controlled manufacturing processes. Every valve is tested in accordance with AWWA C517 and MSS SP-108 on automated hydraulic test rigs with gauges calibrated per ISO standards.

Actuation

The Cam-Centric® Plug Valve is available with a wide range of actuation options, from simple lever operation to advanced pump control systems. Options include 2" operator nuts, worm gears, chainwheels, electric motor and cylinder actuation. A wide variety of accessories such as floor stands and extended bonnets are also available

(see accessories on page 7). Val-Matic Engineering personnel work closely with cylinder and electric actuation manufacturers to assure actuator/valve compatibility. This ensures the actuator you specify will deliver the performance you expect when utilized with a Cam-Centric® Plug Valve.



Direct Nut operated valve with memory stop:

- Adjustable open memory stop for system balancing
- Adjustable close stop
- Adjustable friction collar
- For use with lever accessories



Val-Matic Worm Gears:

- Heavy Duty, totally enclosed and sealed
- For above ground and buried service applications
- Bronze radial bearings and roller thrust bearings provide smooth operations and extended life

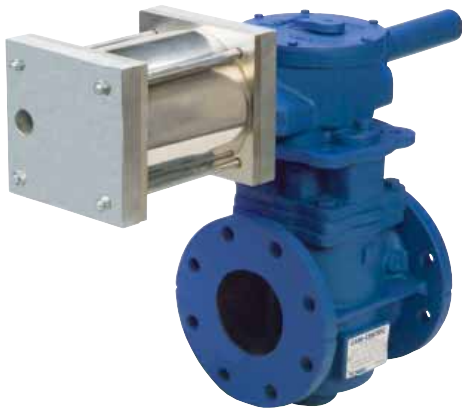

Val-Matic Cylinder Actuation:

- Compliance with AWWA C541 for Power Actuation
- Pneumatic/Hydraulic
- Single Acting or Double Acting
- Fail Open/Closed for power failure
- Modulating Service
- Throttling Service
- Limit Switches, Solenoid Valves, Positioners
- Manual Overrides
- Pump Control



Electric Actuation:

- 110 Single Phase, 230/460 Three Phase
- Compliance with AWWA C542 for Power Actuation
- Modulating Service
- Throttling Service
- Remote push button control and indication
- Torque Switches, Limit Switches
- De-clutchable handwheels
- Available from a wide variety of manufacturers

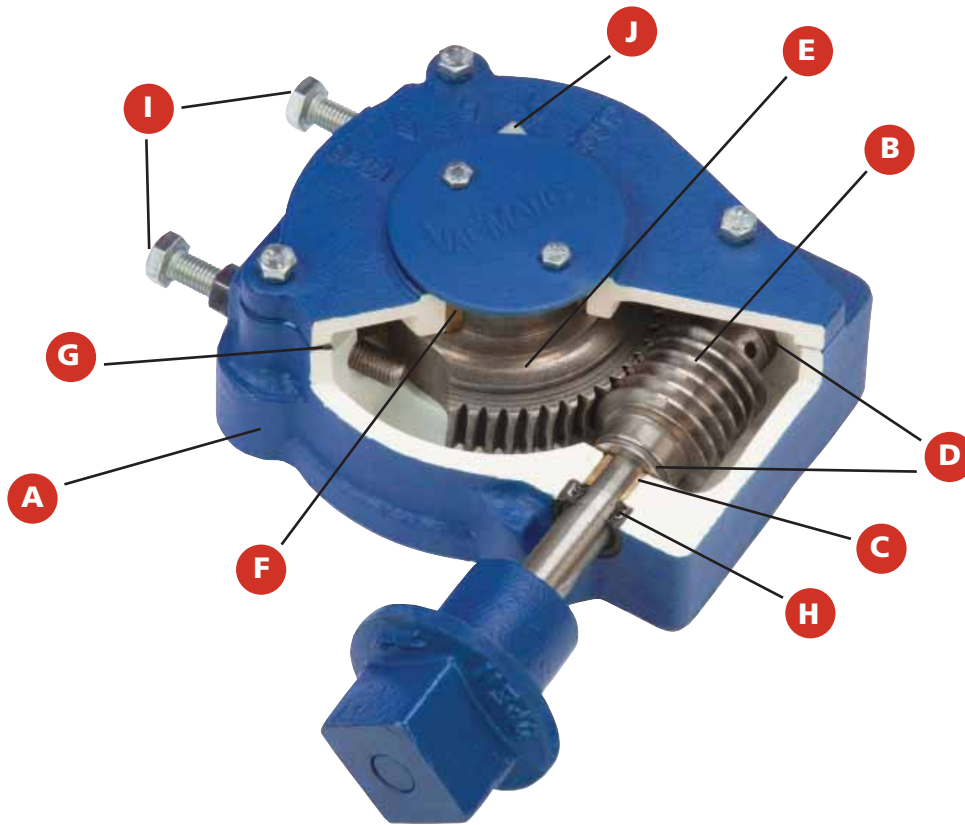

Val-Matic Worm Gear

A valve actuator must perform to the same level as the valve. The Val-Matic worm gear is designed and built to provide the same long term service as our Cam-Centric® Plug Valve. The exclusive bearing package in the worm gear includes four bronze sleeve bearings and two roller thrust bearings. This exclusive package assures smooth operation and long life regardless of the valve's orientation or application. The ductile iron segment gear coupled with the upper and lower bronze radial bearings exceed the requirements of AWWA C517 for strength and durability. All worm gears are designed to exceed, a rim pull of 200 pounds on handwheels and input torques of 300 foot pounds for operator nuts without damage. Buried service worm gears are grease packed, sealed and include stainless steel shafts. Worm gears can be provided with handwheels, chainwheels or 2" operator nuts.

A. Housing

Heavy duty, totally enclosed and sealed.

B. Worm

Hardened steel for durability and long life.

C. Radial Shaft Bearings

Bronze shaft bearings extend life and provide ease of operation (rear shaft bearing not visible).

D. Roller Thrust Bearings

Provides smooth operation and extends life.

E. Segment Gear

Heavy duty ductile iron for high strength. Provided with precision bore and keyway for connection to the valve shaft in multiple positions.

F. Segment Gear Radial Bearings

Upper and lower bronze bearings provide ease of operation and extend life (lower bearing not visible).

G. Cover Gasket

Seals housing and prevents foreign material or moisture from entering actuator and prevents loss of grease.

H. Shaft Seal

Prevents foreign material from entering the actuator.

I. External Stops

Both open and closed stops are external and easily adjustable.

J. Position Indicator

Displays precise plug position on above ground service.

Headloss Chart

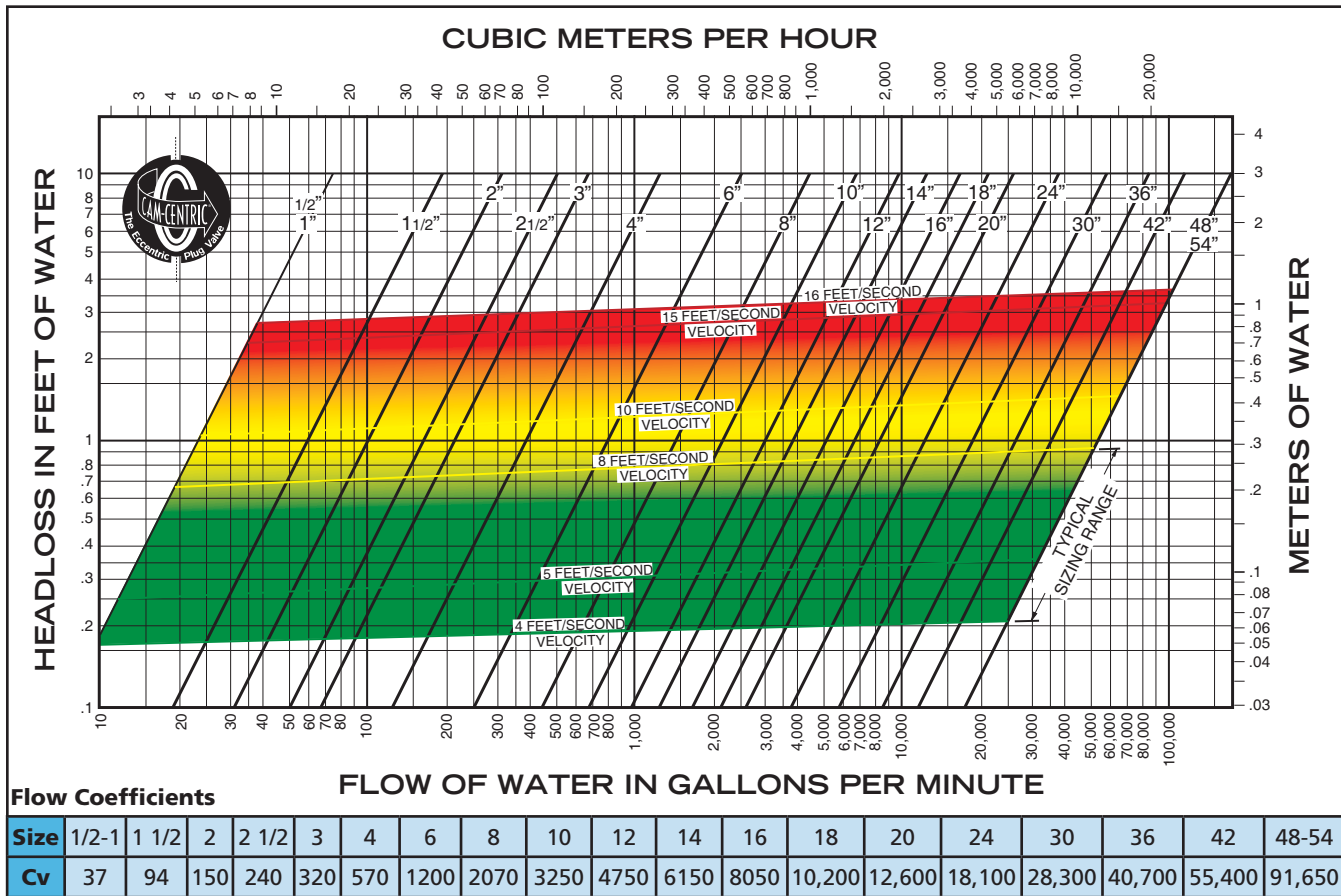

Installation Instructions

The installation of the valve is important for its proper operation. The valve is capable of flow in either direction but the maximum operating pressure can vary with the location of the seat end (Figure 5). The words "SEAT END" are marked on the valve flange.

SUSPENDED SOLIDS SERVICE: For fluids containing suspended solids, special orientations are needed to prevent debris from collecting in the valve. For horizontal installations (Figure 6), the valve should be installed with the flow entering the seat end of the valve and the shaft in a horizontal position with the plug up when open. For vertical installations (Figure 7), the valve must be installed with the seat end up regardless of flow direction.

CLEAN SERVICE: For both horizontal and vertical installations, install in the direct pressure orientation (pressure opposite the seat end).

AIR AND GAS SERVICE: Install valve in the direct pressure orientation (pressure opposite the seat end). Lubricate plug face with FDA approved silicone greases such as Dow Corning #7 before installation. Gear actuators are required for gas service applications.

PUMP DISCHARGE SERVICE: On all horizontal pump discharge applications, the seat end should be towards the pump.

BURIED SERVICE: Gear actuators are recommended for buried valves to hold the valve in position and provide multi-turn closure to prevent water hammer. The valve should be installed with the shaft horizontal and the actuator nut directed upwards. The valve box or extension pipe should be installed so that the actuator nut and extension stem turn freely.

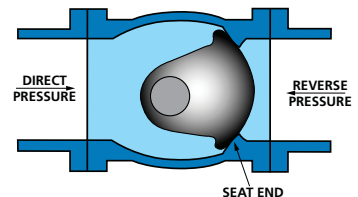

Figure 5. Installation Orientation

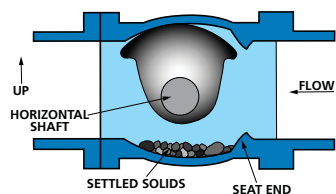

Figure 6. Horizontal Pipe w/ Solids

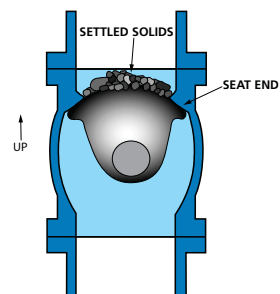

Figure 7. Vertical Pipe with Solids

PRESSURE RATINGS

MAXIMUM PRESSURE RATINGS			
SERIES	CONNECTION	SIZE RANGE	CWP (psig)
5800RTL	ASME NPT Threaded	1/2" - 2"	175
5800R	ANSI Class 125 Flanged	2" - 12"	175
		14" - 54"	150
5800HP	ANSI Class 125 Flanged High Pressure	3" - 24"	250
5900R	AWWA C111 Mechanical Joint	3" - 12"	175
		14" - 48"	150
5900HP	AWWA C111 Mechanical Joint High Pressure	3" - 24"	250

MATERIALS OF CONSTRUCTION

COMPONENT	STANDARD
Body (5800R, 5900R)	Cast Iron ASTM A126, Class B
Body (5800HP, 5900HP)	Ductile Iron ASTM A536, Grade 65-45-12
Plug (5800R, 5900R)	Cast Iron ASTM A126, Class B, Buna-N Encapsulated, ASTM D2000
Plug (5800HP, 5900HP)	Ductile Iron ASTM A536, Grade 65-45-12, Buna-N Encapsulated, ASTM D2000
Radial Shaft Bearings	T316 Stainless Steel
Top Thrust Bearing	PTFE
Bottom Thrust Bearing	T316 Stainless Steel
Available Coatings	Two-Part Epoxy, Fusion Bonded Epoxy, Glass Lining, Rubber Lining

Accessories

Space limitations and application specifics often require special accessories. In addition to those shown below, Val-Matic offers a wide range of accessories to meet your application requirements.

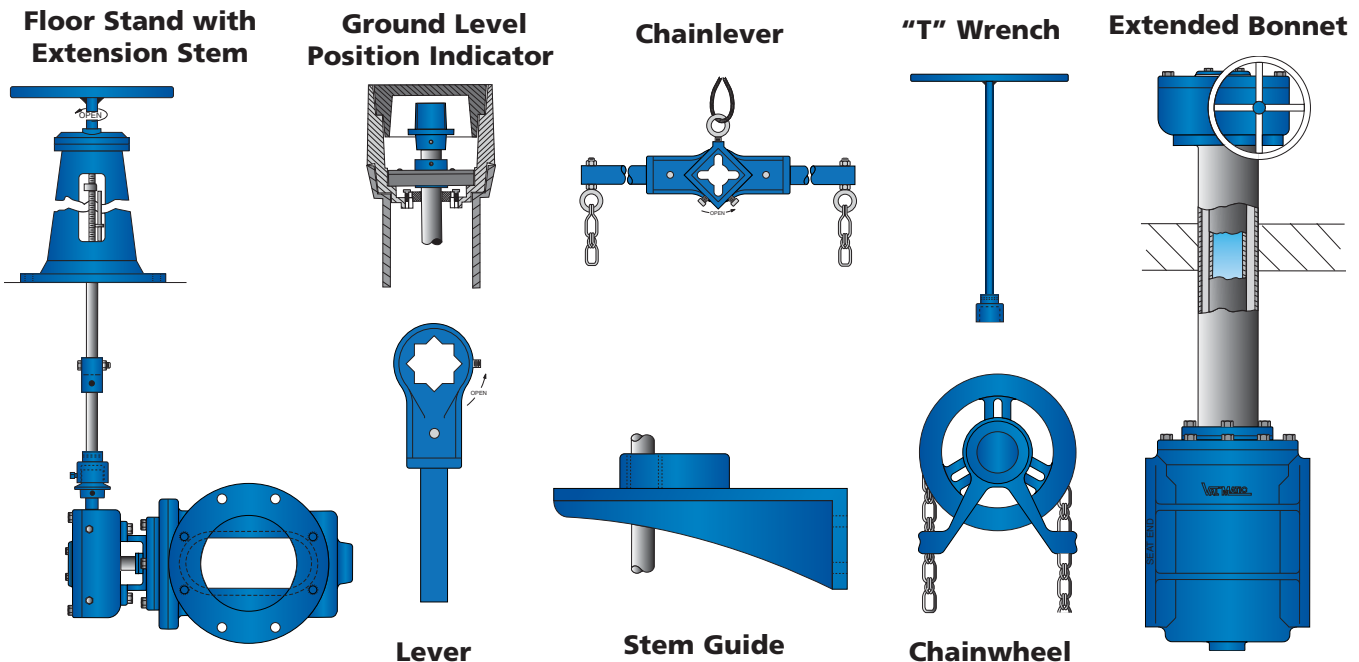

Installation Dimensions

Direct Nut Operated

Flanged, Mechanical Joint, Threaded End Connections

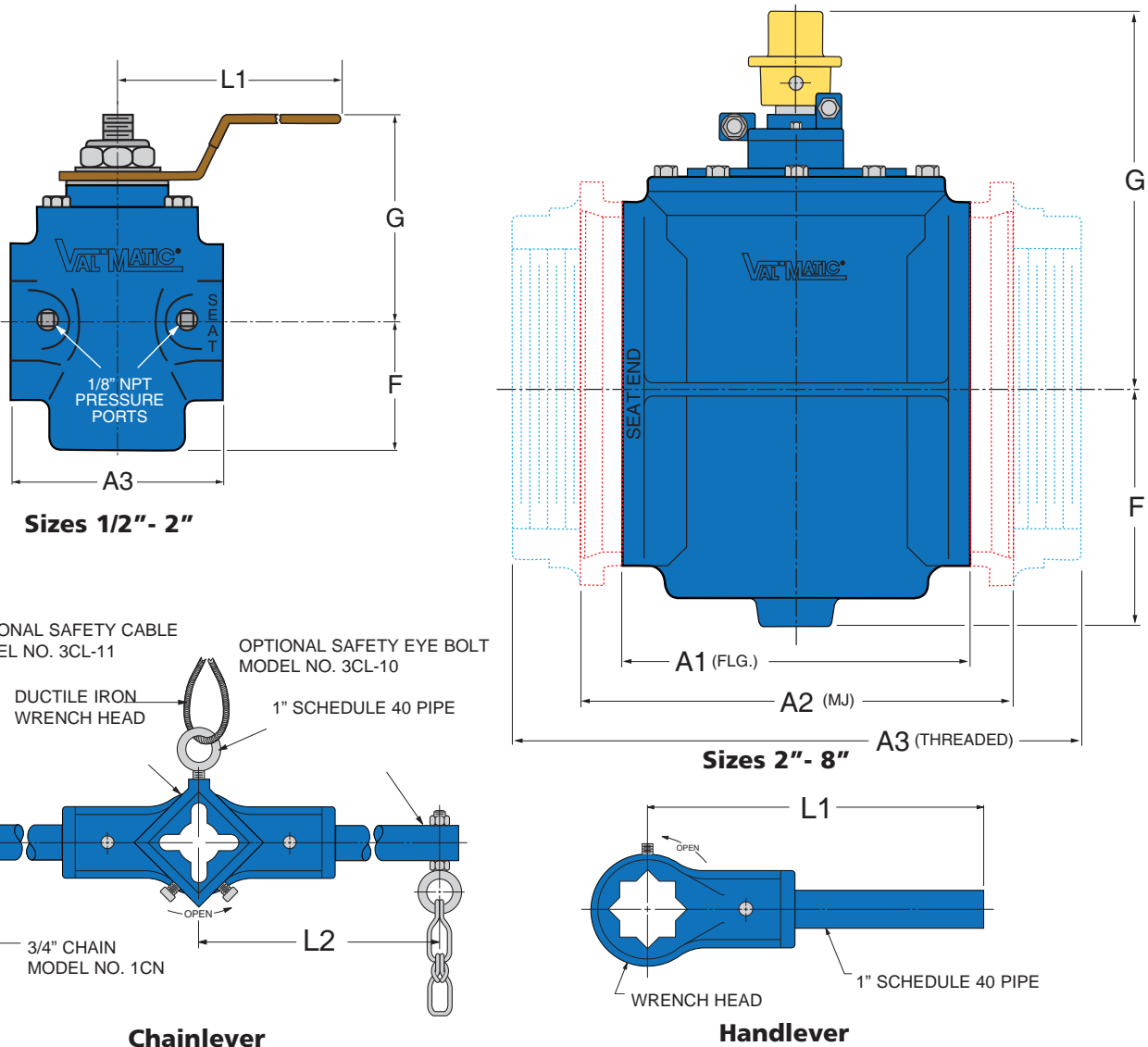

Dimensions in Inches														
Valve Size	Flanged Model No.	MJ Model No.	Threaded Model No.	Handlever Model No.	Chainlever Model No.	Reverse	Direct	A1	A2	A3	F	G	L1	L2
1/2	-	-	5800.5RTL	Std	-	175	175			4.13*	1.88	3.19	4.25	-
3/4	-	-	5800.75RTL	Std	-	175	175			4.13*	1.88	3.19	4.25	-
1	-	-	5801RTL	Std	-	175	175	-	-	3.13	1.88	3.19	4.25	-
1 1/4	-	-	5801.25RTL	Std	-	175	175			6.75*	2.88	4.25	6.50	-
1 1/2	-	-	5801.5RTL	Std	-	175	175			6.75*	2.88	4.25	6.50	-
2	5802RN	-	5802RTL	Std	-	175	175	7.50	-	5.25	2.88	4.25	6.50	-
2 1/2	5825RN	-	5825RTN	4L	3CL	175	175	7.50	-	8.75	4.63	10.00	22.00	16.00
3	5803RN	5903RN	5803RTN	4L	3CL	175	175	8.00	11.50	8.75	4.50	9.63	22.00	16.00
4	5804RN	5904RN	-	4L	4CL	175	175	9.00	14.25	-	5.56	10.94	22.00	22.00
6	5806RN	5906RN	-	8L	6CL	50	100	10.50	15.75	-	7.06	12.31	44.00	32.00
8	5808RN	5908RN	-	8L	8CL	50	100	11.50	17.25	-	8.75	13.88	44.00	44.00

*Asterisk indicates length includes reducing bushing.

Notes: 1. Flange drilling conforms to ANSI B16.1, Class 125.

2. Mechanical Joint (MJ) Ends conform to ANSI/AWWA C110/A21.10.

3. Threaded Ends conform to ANSI/ASME B1.20.1.

4. Handlevers (i.e. 4L) Chainlevers (i.e. 3CL) and Chain (1CN) are ordered separately.

Installation Dimensions

Series 5800R & 5800HP Flanged

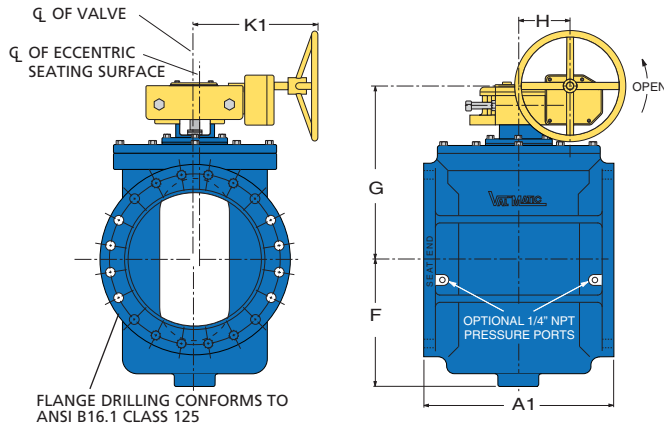

Series 5900R & 5900HP Mechanical Joint

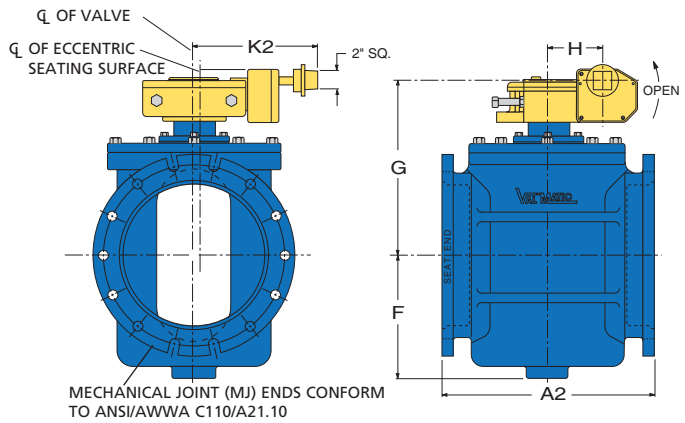

Dimensions in Inches

Valve Size	Flanged Model No.	MJ Model No.	Reverse	Direct	A1	A2	F	G	H	K1	K2		
2 1/2	5825R/7A08*	-	175	175	7.50	-	4.50	7.50	3.06	9.50	-		
3	5803R/7A08*	5903R/8A02A*	175	175	8.00	11.50	4.50	7.50	3.06	9.50	9.00		
	5803HP/7A08*	5903HP/8A02A*	250	250									
4	5804R/7A08*	5904R/8A02*	175	175	9.00	14.25	5.56	9.31	3.06	9.50	9.00		
	5804HP/7A08*	5904HP/8A02*	250	250						11.63			
6	5806R/7A08*	5906R/8A02*	175	175	10.50	15.75	7.06	11.06	3.06	9.50	9.00		
	5806HP/7A12*	5906HP/8A02*	250	250						13.63			
8	5808R/7A12*	-	100	175	11.50	17.25	8.75	12.62	3.06	11.50	9.00		
	5808R/7B16*	5908R/8A02*	175	175						9.38			
	5808HP/7B18*	5908HP/8A02*	250	250									
10	5810R/7C12*	5910R/8C02*	100	175	13.00	18.75	10.44	16.25	4.75	13.13	7.88		
	5810R/7D16*	5910R/8D02*	175	175						11.00			
	5810HP/7D16*	5910HP/8D02*	250	250									
12	5812R/7C16*	5912R/8C02*	100	175	14.00	19.75	12.50	17.69	4.75	11.00	7.88		
	5812R/7D24*	5912R/8D02*	175	175						16.75			
	5812HP/7D24*	5912HP/8D02*	250	250									
14	5814R/7E18*	-	50	100	17.00	24.50	13.00	19.31	5.62	17.50	13.00		
	5814R/7G12	5914R/8F02*	150	150				21.25	9.69	15.50			
	5814HP/7G12	5914HP/8F02*	250	250				20.62	5.62	18.90			
16	5816R/7E24*	-	50	100	17.75	24.75	14.50	22.56	9.69	20.40	13.00		
	5816R/7G14	5916R/8F02*	150	150				22.56	9.69	16.50			
	5816HP/7G18	5916HP/8F02*	250	250				22.25	5.62	20.40			
18	5818R/7J30*	-	50	100	21.50	28.50	16.30	25.12	7.38	19.10	14.50		
	5818R/7L24	5918R/8K02	150	150				20.40	7.38	20.40			
	5818HP/7L24	5918HP/8K02	250	250				19.10	7.38	20.40			
20	5820R/7M18	-	50	100	23.50	30.50	17.50	26.25	7.38	19.10	14.50		
	5820R/7P30	5920R/8K02.5	150	150						20.40		7.38	20.40
	5820HP/7P30	5920HP/8K02.5	250	250						21.90		7.38	21.90
24	5824R/7M24	-	50	100	30.00	37.00	20.25	23.80	4.24	20.90	14.50		
	5824R/7Q36	5924R/8K02.5	150	150						21.70		4.24	21.70
	5824HP/7Q36	5924HP/8K02.5	250	250									
30	5830R/7R24	-	50	100	37.50	45.50	24.00	31.00	3.03	21.90	14.44		
	5830R/7T30	5930R/8S02	150	150				33.20	10.70	31.70	21.70		
36	5836R/7S30	-	50	100	52.00	60.00	29.00	33.00	3.03	23.40	21.70		
	5836R/7W36	5936R/8T02	150	150				35.20	10.70	31.70			
42	5842R/7X30	-	50	100	62.00	70.00	36.50	44.00	14.00	33.80	21.70		
	5842R/7Z36	5942R/8Z02	150	150				42.85	10.90	34.80	27.60		
48	5848R/7X30	-	50	100	84.00	84.00	38.50	48.46	10.90	36.10	21.70		
	5848R/7Z36	5948R/8Z02	150	150						37.10	10.90	27.60	
54	5854R/7X30	-	50	100	96.00	-	38.50	48.46	10.90	36.10	-		
	5854R/7Z36	-	150	150						37.10		10.90	

*Asterisk indicates valve model numbers without spur gear

- Notes:
1. Replace Handwheel (HW) diameter in the model number (i.e. /7A08) with 02 for 2" square operating nut (i.e./7A02).
 2. Add a C suffix to model number to include Chainwheel Kit (i.e. 5804R/7A08C).
 3. Available with ISO/PN drilling.
 4. Consult factory for larger sizes.

Flow Characteristics

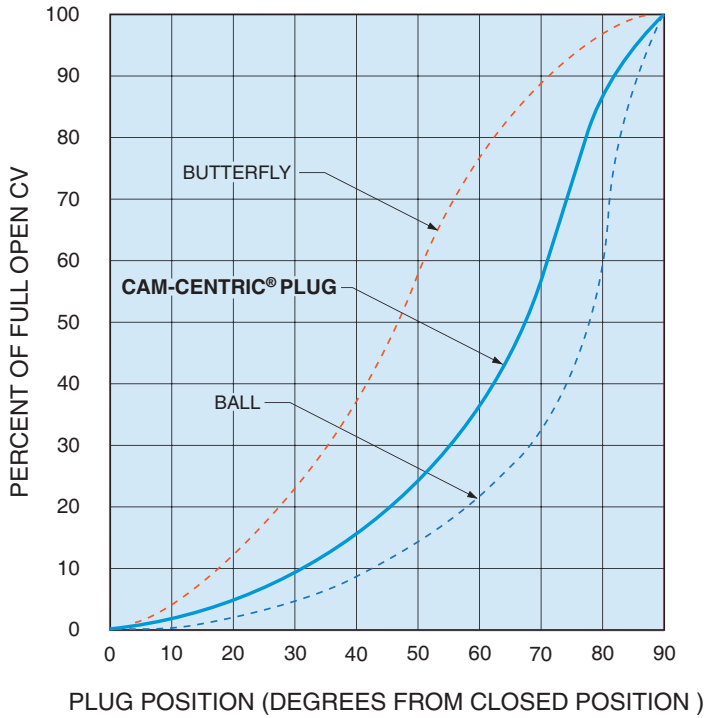

INHERENT PUMP CONTROL FLOW CHARACTERISTICS

To control pressure surges and provide good controllability, the flow characteristics of valves should be considered.

The graph at left shows the inherent flow characteristics at a constant ΔP for various valves.

The Plug Valve has an inherent flow characteristic similar to a ball valve. When installed in a pipeline, the plug valve will approximate a linear flow characteristic because the piping system pressure losses will shift the flow curve to the left. A linear installed flow characteristic will help control surges and provide a wide range of controllability.

Installations



Cam-Centric® Plug Valve with worm gear actuator and chainwheel



Cam-Centric® Plug Valve with Val-Matic Swing-Flex®



Cam-Centric® Plug Valve with Val-Matic dual body combination Air Valve



Cam-Centric® Plug Valve with motor actuator



Cam-Centric® Plug Valve with worm gear actuator



Cam-Centric® Plug Valve with worm gear actuator and extension stem

SCOPE

- 1.1 This specification covers the design, manufacture, and testing of 1/2 in. (15 mm) through 3 in. (80 mm) Threaded Eccentric Plug Valve, 2 1/2 in. (60 mm) through 72 in. (1800 mm) Eccentric Plug Valve suitable for water or wastewater service with pressures up to 250 psig (1725 kPa).
- 1.2 Plug Valves shall be quarter-turn, non-lubricated with resilient encapsulated plug.

STANDARDS AND APPROVALS

- 2.1 2 1/2 in. (60 mm) through 60 in. (1500 mm) plug valves shall be designed, manufactured and tested in accordance with American Water Works Association Standard ANSI/AWWA C517.
- 2.2 All Plug Valves shall be certified Lead-Free in accordance with NSF/ANSI 372.
- 2.3 Manufacturer shall have a quality management system that is certified to ISO 9001 by an accredited, certifying body.

CONNECTIONS

- 3.1 Threaded valves shall have threaded NPT full size inlets. The connection shall be hexagonal for a wrench connection.
- 3.2 Flanged valves shall have flanges with drilling to ANSI B16.1, Class 125.
- 3.3 Mechanical Joint valves shall fully comply with ANSI/AWWA C111/A21.11.

DESIGN

- 4.1 Threaded and all other valves under 4" (100mm) shall have port areas of not less than 100% of pipe area. Port areas on other sizes are 85% on 16" (400 mm) and smaller, 80% on 18"-24" (150 mm- 600 mm), and 75% on 30" (800 mm) and larger.
- 4.2 Threaded valve seat shall be a machined seating surface.
- 4.3 2 1/2 in. (60 mm) through 72 in. (1800 mm) plug valves shall have a valve seat that is a welded overlay of 95% pure nickel applied directly to the body on a pre-machined, cast seating surface and machined to a smooth finish.
- 4.4 Threaded valves shall have shaft seals which consist of V-type lip seal in a fixed gland with a resilient O-ring spring.
- 4.5 2 1/2 in. (60 mm) through 72 in. (1800 mm) plug valves shall have shaft seals which consist of V-type packing in a fixed gland with an adjustable follower designed to prevent over compression of the packing and to meet design parameter of the packing manufacturer. Removable POP™ shims shall be provided under the follower flanges to provide for adjustment and prevent over tightening.
- 4.6 Permanently lubricated, radial shaft bearings shall be supplied in the upper and lower bearing journals. Thrust bearings shall be provided in the upper and lower journal areas, except for threaded type which only have upper thrust bearings.
- 4.7 Both the packing and bearings in the upper and lower journals shall be protected by a Grit-Guard™ "drip tight" Buna-N shaft seal located on the valve shaft to minimize the entrance of grit into the bearing journal and shaft seal areas.
- 4.8 The threaded valve body shall have 1/8" NPT upstream and downstream pressure ports.

MATERIALS

- 5.1 Valve bodies and covers shall be constructed of ASTM A126 Class B cast iron for working pressures up to 175 psig (1200 kPa) and ASTM A536 Grade 65-45-12 for working pressures up to 250 psig (1725 kPa). The words "SEAT END" shall be cast on the exterior of the body seat end.
- 5.2 Threaded valve plugs in sizes 1/2 in. (15 mm) through 3 in. (80 mm) shall be of one-piece construction and made of ASTM A126 Class B cast iron

- fully encapsulated with a resilient facing per ASTM D2000-BG and ANSI/AWWA C517 requirements.
- 5.3 2 1/2 in. (60 mm) through 72 in. (1800 mm) plugs shall be of one-piece construction and made of ASTM A126 Class B cast iron or ASTM A536 Grade 65-45-12 ductile iron and fully encapsulated with resilient facing per ASTM D2000-BG and ANSI/AWWA C517 requirements.
- 5.4 Threaded valves shall have radial shaft bearings constructed of self-lubricating Type 316 stainless steel. The top thrust bearing shall be PTFE.
- 5.5 2 1/2 in. (60 mm) through 72 in. (1800 mm) plug valves shall have radial shaft bearings constructed of self-lubricating Type 316 stainless steel. The top thrust bearing shall be PTFE. The bottom thrust bearing shall be self-lubricating Type 316 stainless steel. Cover bolts shall be corrosion resistant with zinc plating.

ACTUATION

- 6.1 Threaded valves shall be equipped with a hand lever with a dial indicator and open memory stop.
- 6.2 Valves 2 1/2 in. (60 mm) to 8 in. (200 mm) and 4 in. (100mm) to 6 in. (150 mm) 100% ported shall be equipped with a 2 inch square nut for direct quarter turn operation. The packing gland shall include a friction collar and an open position memory stop. The friction collar shall include a nylon sleeve to provide friction without exerting pressure on the valve packing.
- 6.3 When specified valves 4 in. (100 mm) and larger shall include a totally enclosed and sealed worm gear actuator with position indicator (above ground service only) and externally adjustable open and closed stops. The worm segment gear shall be ASTM A536 Grade 65-45-12 ductile iron with a precision bore and keyway for connection to the valve shaft. Bronze radial bearings shall be provided for the segment gear and worm shaft. Alloy steel roller thrust bearings shall be provided for the hardened worm.
- 6.4 All gear actuators shall be designed to withstand, without damage, a rim pull of 200 lb. on the hand wheel and an input torque or 300 ft-lbs. for nuts.
- 6.5 Buried service actuators shall be packed with grease and sealed for temporary submergence to 20 feet of water. Exposed worm shafts shall be stainless steel.

OPTIONS

- 7.1 When specified, the valve port area shall have not less than 100% of pipe area.
- 7.2 The interior and exterior of the valve shall be coated with an NSF/ANSI 61 approved fusion bonded epoxy.
- 7.3 The interior of the valve shall be coated with 8 mils SG-14 glass lining or 1/8" soft rubber lining.

MANUFACTURE

- 8.1 Manufacturer shall demonstrate a minimum of ten (10) years' experience in the manufacture of plug valves. When requested, the manufacturer shall provide test certificates, dimensional drawings, parts list drawings and operation and maintenance manuals.
- 8.2 The exterior of the valve for above ground service shall be coated with a universal alkyd primer. Valve exterior for buried service shall be coated with an epoxy coating.
- 8.3 Valve shall be marked with the Serial Number, Manufacturer, Size, Cold Working Pressure (CWP) and the Direct and Reverse Actuator Pressure Ratings on a corrosion resistant nameplate.
- 8.4 Plug Valves shall be Series # 5800RTL (Threaded), 5800R (Flanged), 5800HP (Flanged), 5900R (Mechanical Joint) or 5900HP (Mechanical Joint) as manufactured by Val-Matic Valve and Mfg. Corporation, Elmhurst, IL. USA or approved equal.



*Cam-Centric® Plug Valve
fully encapsulated plug*



State-of-the-art robotic welding system for Cam-Centric® Plug Valve

VAL-MATIC®



Cam-Centric®
100% Port
Plug Valves



Meets AWWA C517
NSF/ANSI 61 & 372 Certified

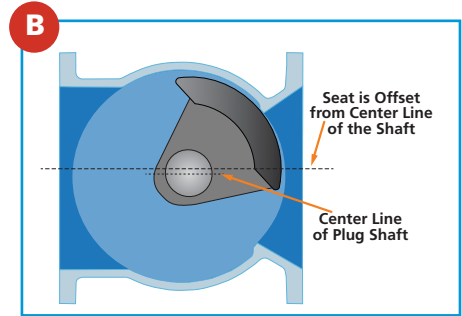
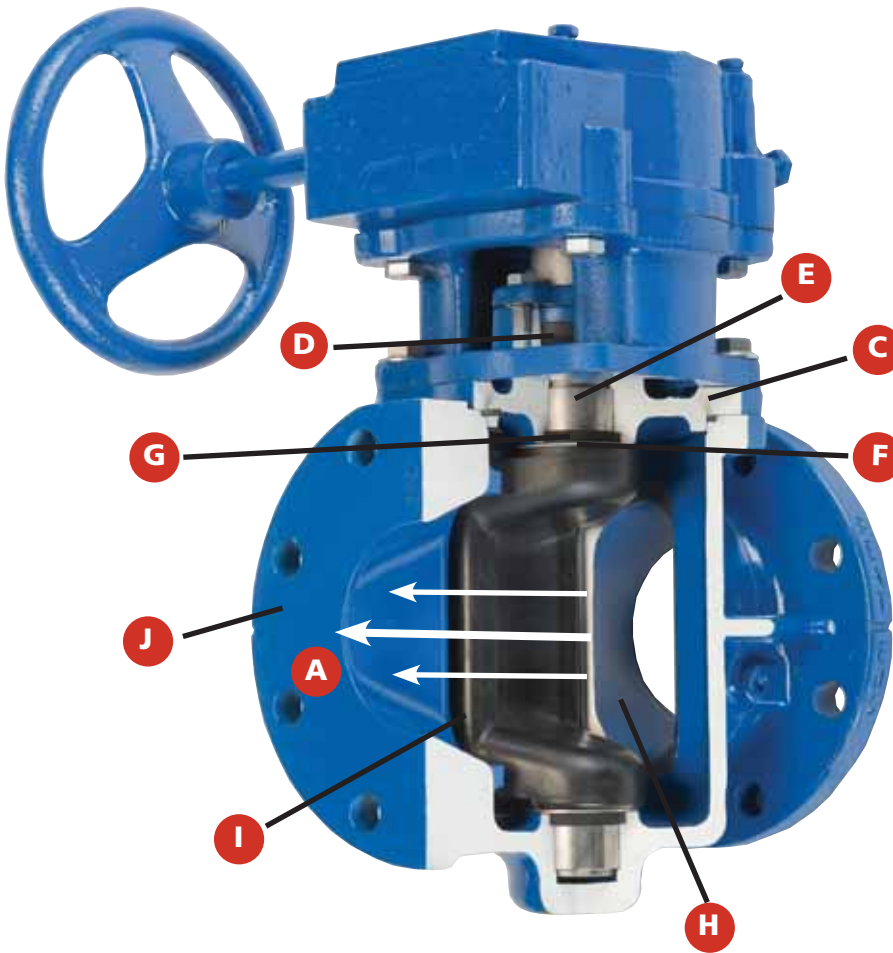

Figure 1. Eccentric Action

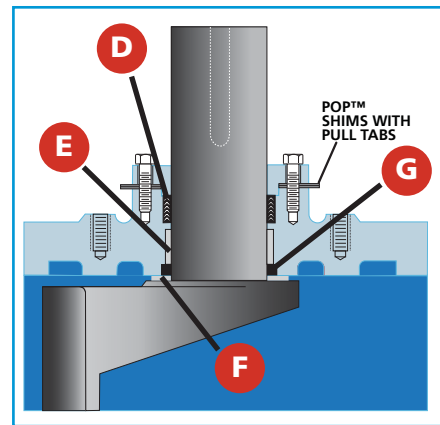

Figure 2. Upper Bearing Journal

A. 100% Port

The rectangular port area matches the full pipe area for low head-loss and non-clog performance. The full discharge downstream port has no restriction to provide maximum flushing action.

B. Eccentric Action

Provides positive shut off in both directions at full rating with wear resistant action and low torque.

C. Full Top Access Cover with Adjustable Packing

The removable full size top access cover enables maintenance and inspection without valve removal. The packing is adjustable and replaceable without removal of the actuator.

D. V-Packing

V-Type packing gland with removable POP™ shims for controlled adjustment and long packing life.

E. Radial Bearings

Heavy Duty, T316 Stainless Steel, Permanently Lubricated.

F. Thrust Bearing

Upper and Lower PTFE thrust bearings provides ease of actuation during operating conditions.

G. Grit-Guard™ Shaft Seal

The resilient molded *Val-Matic Exclusive* Grit-Guard™ seals extend packing and bearing life by reducing wear and infiltration of grit.

H. Seat

The robotic pulsed-arc welded 95% nickel raised seat is corrosion and wear resistant.

I. Plug

The plug is contoured and out of the flow path when open for reduced headloss and energy efficiency. The rigid ductile iron plug is fully encapsulated with molded rubber in all sizes for maximum resistance to corrosion and wear.

J. End Connections

Flange mating dimensions comply with ANSI Class 125. Mechanical Joint dimensions comply with AWWA C111. Laying lengths comply with AWWA C517.

Proven Design

With installations worldwide, the Val-Matic Cam-Centric® Plug Valve has proven itself as the preferred valve for wastewater, industrial waste and process applications. The Cam-Centric® Plug Valve is a ¼ turn eccentric plug valve allowing cost effective, low torque actuation for pump control, shut-off and throttling service. The valve's eccentric action rotates the plug in and out of the seated position with minimal contact, thereby preventing high torque and wear to the valve seat and plug. The combination of the eccentric action, stainless steel bearings, Grit-Guard™ seals and heavy duty nickel seat assures long life with minimal maintenance.

Preferred Features

The Cam-Centric® Plug Valve features a shaft sealing system that utilizes V-Type packing, a packing follower and a Grit-Guard™ seal for ease of maintenance and to reduce wear. The Grit-Guard™ seals reduce wear by preventing grit and media from reaching the bearings and packing to prevent plug lock up. The seals are standard in both the upper and lower journals (Figure 2). To prevent the packing from being over tightened, the shaft seal incorporates POP™ (Packing Overload Protection) Shims. The packing is easily adjusted by removing the POP™ shims as necessary utilizing the pull tab feature (Figure 2). Adjustment or replacement of the V-Type packing can be done without removal of the gear, motor or cylinder actuator.



Figure 3. Full Discharge Port

The outlet of the Cam-Centric® Plug Valve contains a full discharge port that is specifically designed to prevent clogging in wastewater and slurry services. The port provides full flushing action, draining the sediment and grit from the valve during cycling. The outlet is equal to the pipe size, yields low headloss and enables cleaning of the pipeline with a resilient, high-density polyurethane foam pig (Figure 3).

The Cam-Centric® bearing package consists of permanently lubricated, T316 stainless steel radial bearings in both the upper and lower journals. The thrust bearings are made of PTFE for ease of operation. The bearings are protected from grit-related wear by the resilient Grit-Guard™ seals.

The Cam-Centric® Plug Valve utilizes a contoured and totally encapsulated molded plug to reduce corrosion and wear in severe abrasive applications. Its ductile iron construction provides strength and rigidity to withstand dynamic forces from flow and pressure.



Figure 4. Robotic welding of nickel seat

The valve seat is a welded overlay of 99% pure nickel applied directly to the body on a machined surface using a state-of-the-art robotic pulse-arc welding system for a consistent, high quality weld (Figure 4).

Advanced Technology

Incorporating the latest in valve technology assures a high-quality valve that will provide long service. The design process utilized solid modeling and finite element analysis (FEA) of the key structural components. Flow and torque data was derived from flow tests, mathematical models and computational fluid dynamics (CFD). Manufacturing technology uses automated process control in the foundry and ISO 9001 controlled manufacturing processes. Every valve is tested in accordance with AWWA C517 and MSS SP-108 on automated hydraulic test rigs with gauges calibrated in accordance with ISO standards.

Worm Gear Features

Val-Matic Worm Gear

A valve actuator must perform to the same level as the valve. The Val-Matic worm gear is designed and built to provide the same long term service as our Cam-Centric® Plug Valve. The exclusive bearing package in the worm gear includes four bronze sleeve bearings and two roller thrust bearings. This exclusive package assures smooth operation and long life regardless of the valve's orientation or application. The ductile iron segment gear coupled with the upper and lower bronze radial bearings exceed the requirements of AWWA C517 for strength and durability. All worm gears are designed to withstand a rim pull of 200 pounds on handwheels and an input torque of 300 foot pounds for operator nuts without damage. Buried service worm gear input shafts are corrosion resistant, the housing is packed with grease, and the indicator is replaced with a blind cover. Worm gears can be provided with handwheels, chainwheels or 2 inch operator nuts.

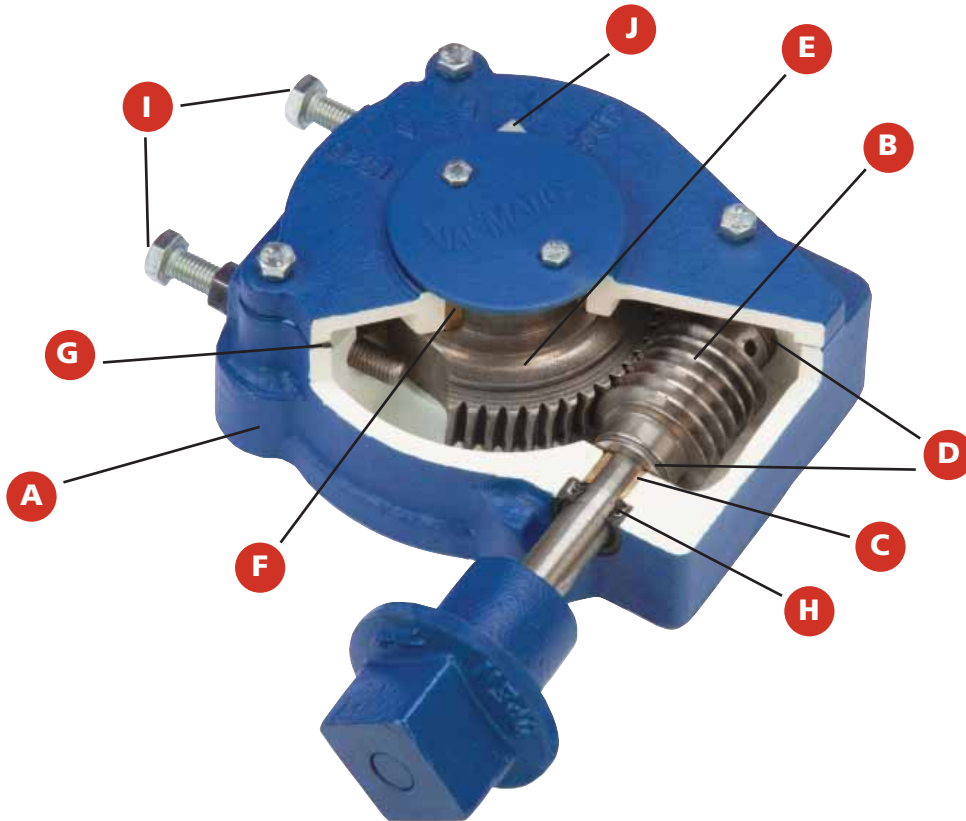

A. Housing

Heavy duty, totally enclosed and sealed.

B. Worm

Hardened steel for durability and long life.

C. Radial Shaft Bearings

Bronze shaft bearings extend life and provide ease of operation (rear shaft bearing not visible).

D. Roller Thrust Bearings

Provides smooth operation and extends life.

E. Segment Gear

Heavy duty ductile iron for high strength. Provided with precision bore and keyway for connection to the valve shaft in multiple positions.

F. Segment Gear Radial Bearings

Upper and lower bronze bearings provide ease of operation and extend life (lower bearing not visible).

G. Cover Gasket

Seals housing and prevents foreign material from entering actuator and prevents loss of grease.

H. Shaft Seal

Prevents foreign material from entering the actuator.

I. External Stops

Both open and closed stops are external and easily adjustable.

J. Position Indicator

Displays precise plug position on above ground service.

The Cam-Centric® Plug Valve is available with a wide range of actuation options, from simple lever operation to advanced pump control systems. Options include 2" operator nuts, worm gears, chainwheels, electric motor and cylinder actuation. A wide variety of accessories such as floor stands and extended bonnets are also available (see accessories on page 7). Val-Matic Engineering personnel work closely with cylinder and electric actuation manufacturers to assure actuator/valve compatibility. This assures the actuator you specify will deliver the performance you expect when utilized with a Cam-Centric® Plug Valve.



Direct Nut operated valve with memory stop:

- Adjustable open memory stop for system balancing
- Adjustable close stop
- Adjustable friction collar
- For use with lever accessories



Val-Matic Worm Gears:

- Heavy Duty, totally enclosed and sealed
- For above ground and buried service applications
- Bronze radial bearings and roller thrust bearings provide smooth operations and extended life

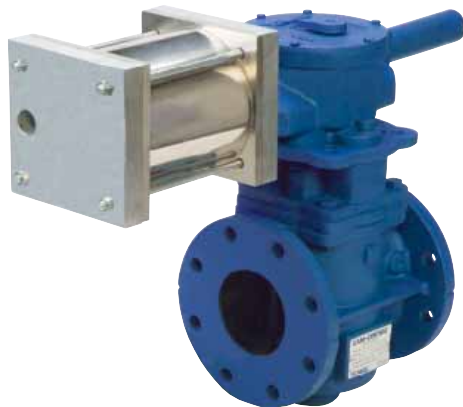

Val-Matic Cylinder Actuation:

- Compliance with AWWA C541 for Power Actuation
- Pneumatic/Hydraulic
- Single Acting or Double Acting
- Fail Open/Closed for power failure
- Modulating Service
- Throttling Service
- Limit Switches, Solenoid Valves, Positioners
- Manual Overrides
- Pump Control



Electric Actuation:

- 110 Single Phase, 230/460 Three Phase
- Compliance with AWWA C542 for Power Actuation
- Modulating Service
- Throttling Service
- Remote push button control and indication
- Torque Switches, Limit Switches
- De-clutchable handwheels
- Available from a wide variety of manufacturers

Headloss Chart

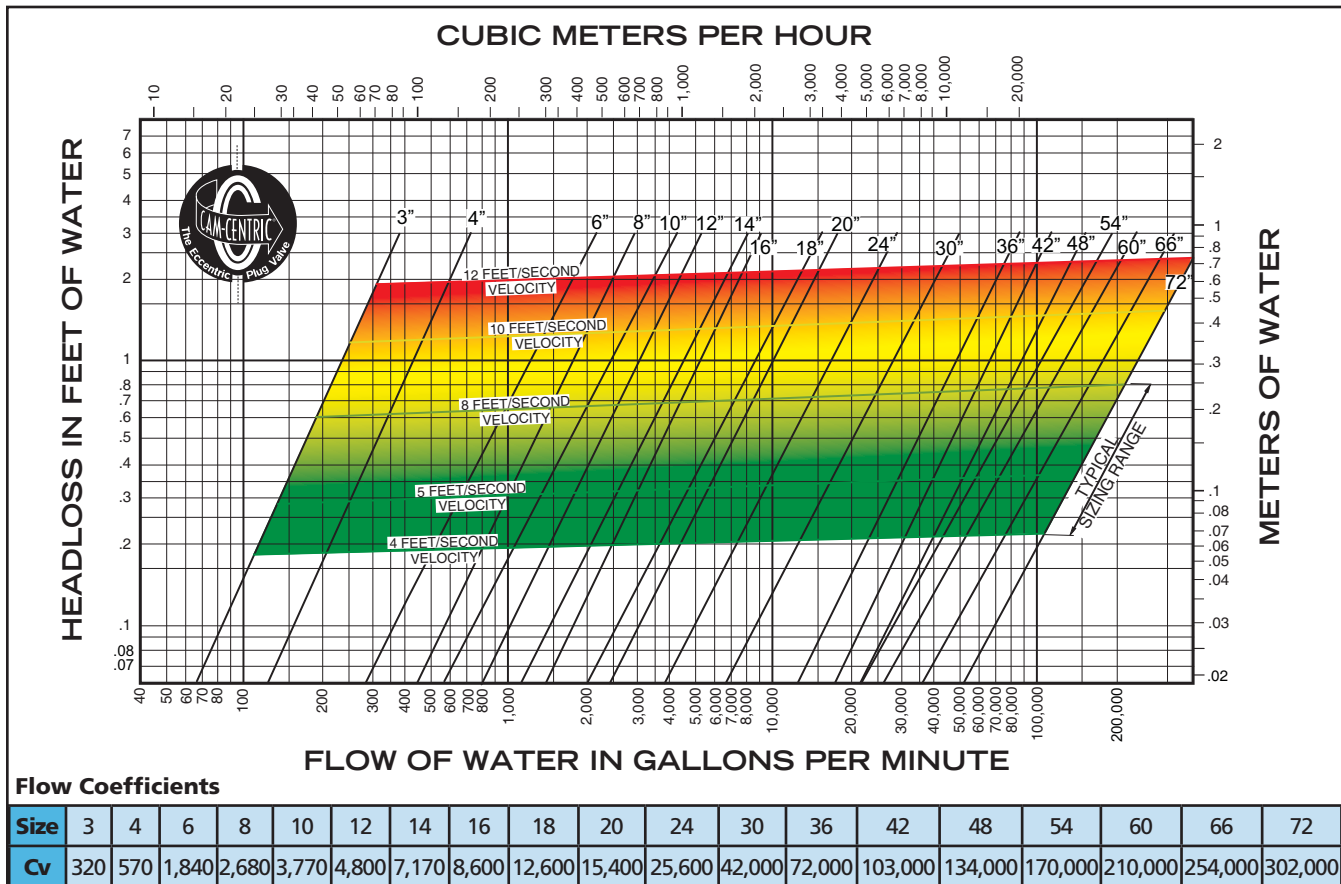

Installation Instructions

The installation of the valve is important for its proper operation. The valve is capable of flow in either direction but the maximum operating pressure can vary with the location of the seat end (Figure 5). The words "SEAT END" are marked on the valve flange.

SUSPENDED SOLIDS SERVICE: For fluids containing suspended solids, special orientations are needed to prevent debris from collecting in the valve. For horizontal installations (Figure 6), the valve should be installed with the flow entering the seat end of the valve and the shaft in a horizontal position with the plug up when open. For vertical installations (Figure 7), the valve must be installed with the seat end up regardless of flow direction.

CLEAN SERVICE: For both horizontal and vertical installations, install in the direct pressure orientation (pressure opposite the seat end).

AIR AND GAS SERVICE: Install valve in the direct pressure orientation (pressure opposite the seat end). Lubricate plug face with FDA approved silicone greases such as Dow Corning #7 before installation. Gear actuators are required for gas service applications.

PUMP DISCHARGE SERVICE: On all horizontal pump discharge applications, the seat end should be towards the pump.

BURIED SERVICE: Gear actuators are recommended for buried valves to hold the valve in position and provide multi-turn closure to prevent water hammer. The valve should be installed with the shaft horizontal and the actuator nut directed upwards. The valve box or extension pipe should be installed so that the actuator nut and extension stem turn freely.

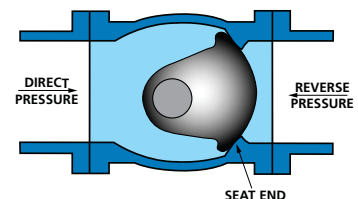

Figure 5. Installation Orientation

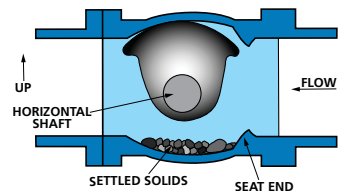

Figure 6. Horizontal Pipe w/ Solids

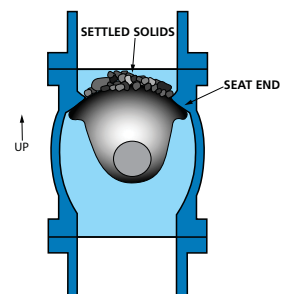

Figure 7. Vertical Pipe with Solids

PRESSURE RATINGS

MAXIMUM PRESSURE RATINGS			
SERIES	CONNECTION	SIZE RANGE	CWP (psig)
5600F	ANSI Class 125 Flanged 100% Port	3" - 12"	175
		14" - 72"	150
5700F	AWWA C111 Mechanical Joint 100% Port	3" - 12"	175
		14" - 54"	150
5600HP	ANSI Class 125 Flanged 100% Port High Pressure	6" - 20"	250
5700HP	ANSI Class 125 Mechanical Joint 100% Port High Pressure	6" - 20"	250

MATERIALS OF CONSTRUCTION

COMPONENT	STANDARD
Body (5600F, 5700F)	Cast Iron ASTM A126, Class B
Body (5600HP, 5700HP)	Ductile Iron ASTM A536, Grade 65-45-12
Plug and Integral Shaft	Ductile Iron ASTM A536, Grade 65-45-12, Buna-N Encapsulated, ASTM D2000
Radial Shaft Bearings	T316 Stainless Steel
Top and Bottom Thrust Bearings	PTFE
Available Coatings	Two-Part Epoxy, Fusion Bonded Epoxy, Glass Lining, Rubber Lining

Accessories

Space limitations and application specifics often require special accessories. In addition to those shown below, Val-Matic offers a wide range of accessories to meet your application requirements.

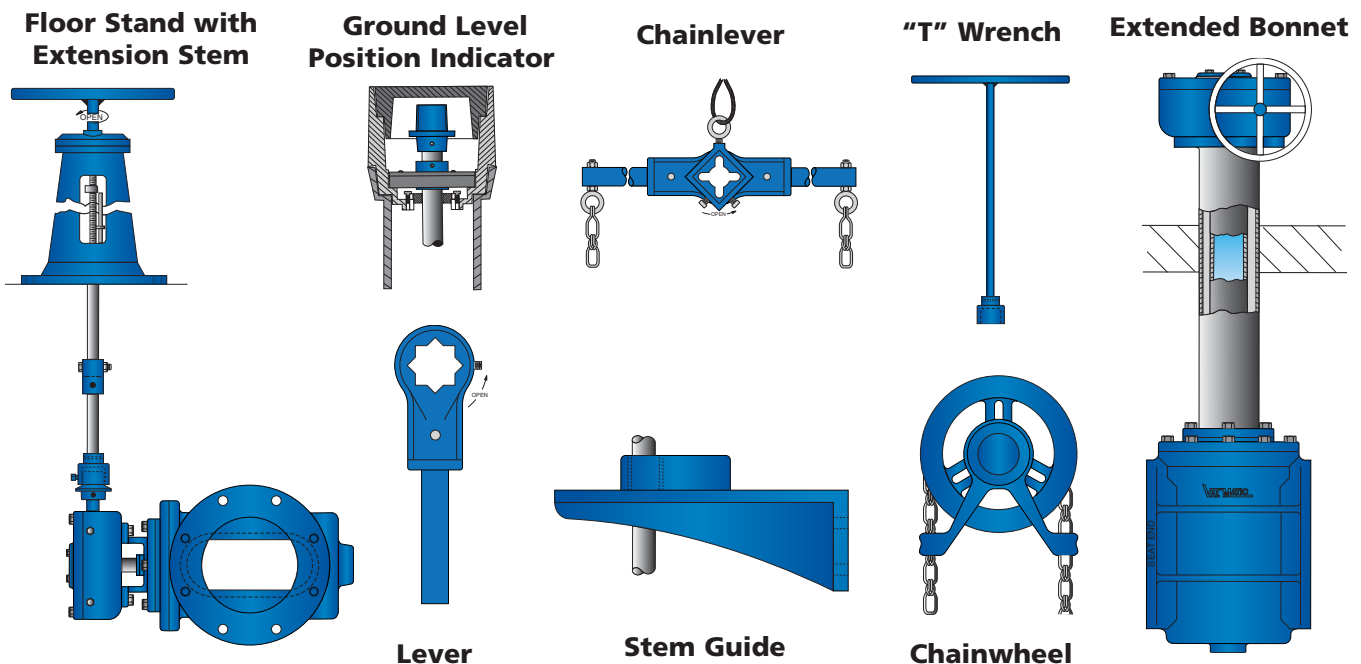

Installation Dimensions

Direct Nut Operated
Flanged, Mechanical Joint

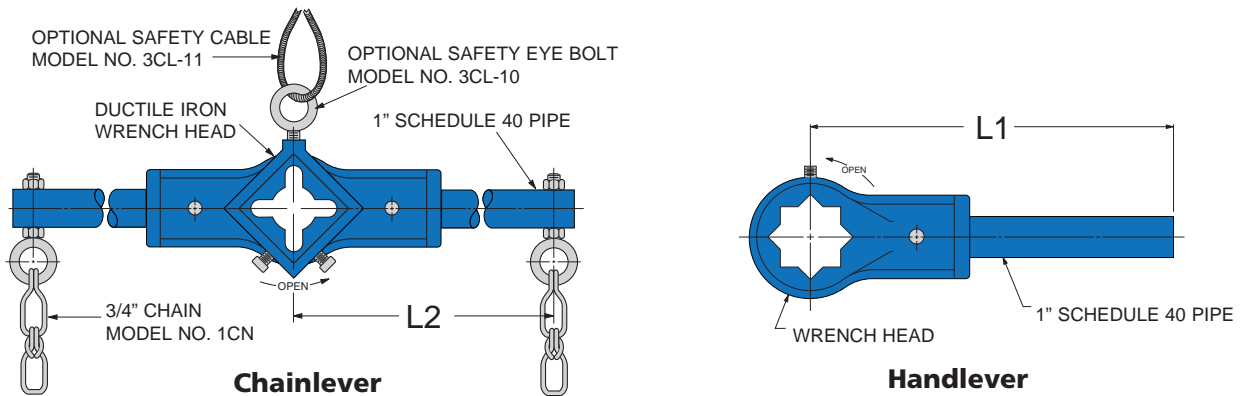
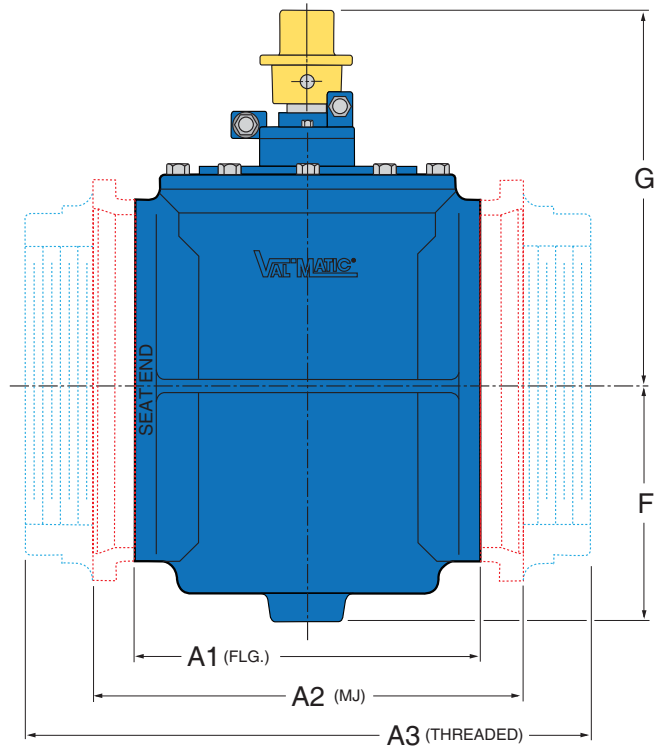

Dimensions in Inches												
Valve Size	Flanged Model No.	MJ Model No.	Handlever Model No.	Chainlever Model No.	Reverse	Direct	A1	A2	F	G	L1	L2
3	5603FN	5703FN	4L	3CL	175	175	8.00	11.50	4.63	10.00	22.00	16.00
4	5604FN	5704FN	4L	4CL	175	175	9.00	14.25	5.56	10.93	22.00	22.00
6	5606FN	5706FN	8L	6CL	50	100	10.50	15.75	7.06	12.31	44.00	32.00
8	5608FN	5708FN	8L	8CL	50	100	11.50	17.25	8.75	14.00	44.00	44.00

- Notes: 1. Flange drilling conforms to ANSI B16.1, Class 125.
2. Mechanical Joint (MJ) Ends conform to ANSI/AWWA C110/A21.10.
3. Handlevers (i.e. 4L) Chainlevers (i.e. 3CL) and Chain (1CN) are ordered separately.

Installation Dimensions

Flanged & Mechanical Joint End Connections

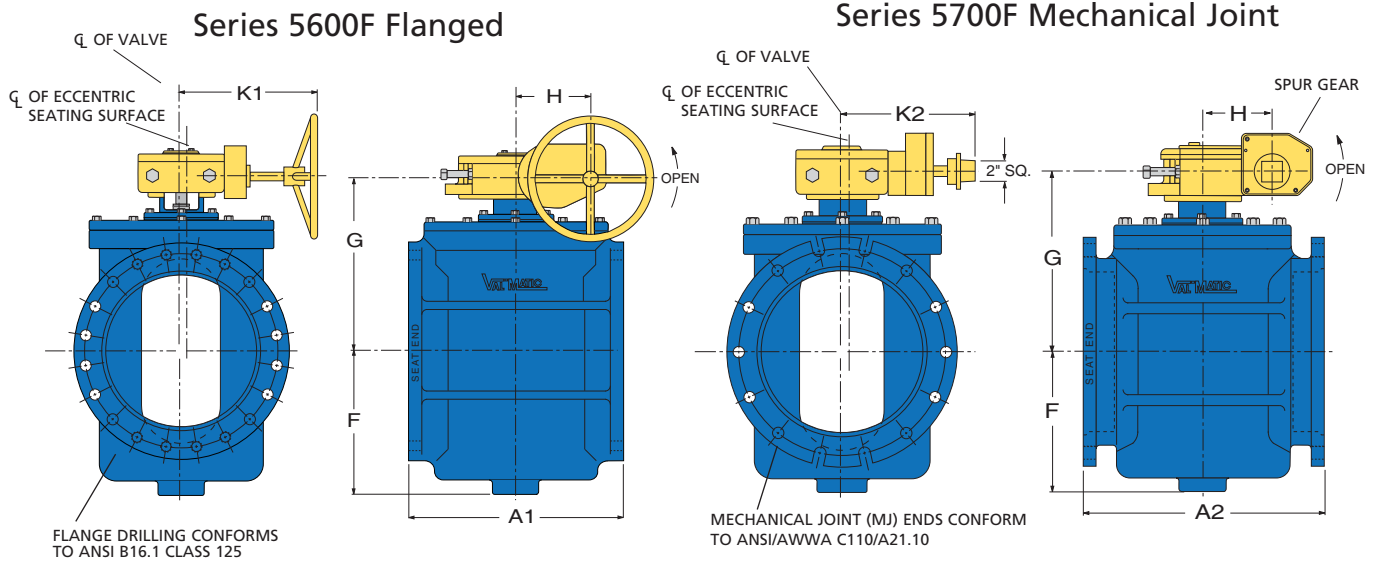

Dimensions in Inches											
Valve Size	Flanged Model No.	MJ Model No.	Reverse PSI	Direct PSI	A1	A2	F	G	H	K1	K2
3	5603F/7A08	5703F/8A02A	175	175	8.00	11.50	4.50	7.50	3.06	9.50	9.00
4	5604F/7A08	5704F/8A02	175	175	9.00	14.25	5.56	9.31	3.06	9.50	9.00
6	5606F/5A08	5706F/6A02	175	175	10.50	15.75	7.06	11.38	3.06	13.10	9.00
8	5608F/5B16	5708F/6B02	175	175	11.50	17.25	8.75	12.01	3.06	13.10	9.00
10	5610F/5D16	5710F/6D02	175	175	13.00	18.75	10.40	15.19	4.75	14.90	7.88
12	5612F/5D24	5712F/6F02	175	175	14.00	19.75	13.00	17.49	4.75	18.90	7.88
14	5614F/5F24	5714F/6F02	150	150	17.00	24.50	13.00	19.21	5.62	20.30	13.00
16	5616F/5J18	5716F/6J02	150	150	17.75	24.69	15.63	23.10	9.69	16.00	13.00
18	5618F/5L24	5718F/6M02	150	150	21.50	28.50	15.63	23.00	9.69	17.70	13.00
20	5620F/5Q30	5720F/6Q02	150	150	23.50	30.50	17.50	24.70	7.30	21.90	14.50
24	5624F/5T30	5724F/6T02	150	150	30.00	37.00	18.81	23.90	4.24	21.70	15.20
30	5630F/5W24	5730F/6W02	150	150	37.50	45.50	24.00	27.30	2.77	25.00	20.10
36	5636F/5Z24	5736F/6Z02	150	150	52.00	61.88	27.00	33.03	4.91	27.30	20.60
42	5642F/5Z30	5742F/6Z02	150	150	62.00	72.00	36.40	44.70	14.00	32.10	25.30
48	5648F/5Z36	5748F/6Z02	150	150	72.00	84.00	36.40	50.40	10.90	37.10	27.60
54	5654F/5ZA24	5754F/6ZA02	150	150	96.00	-	39.10	55.50	4.80	37.60	27.60

Consult factory for larger sizes.

- Notes:
1. Replace handwheel (HW) diameter in the model number (i.e. /5A08) with 02 for 2" square operating nut (i.e./5A02).
 2. Add a C suffix to model number to include Chainwheel Kit (i.e. 5606F/5A08C).
 3. Available with ISO/PN drilling.

Flow Characteristics

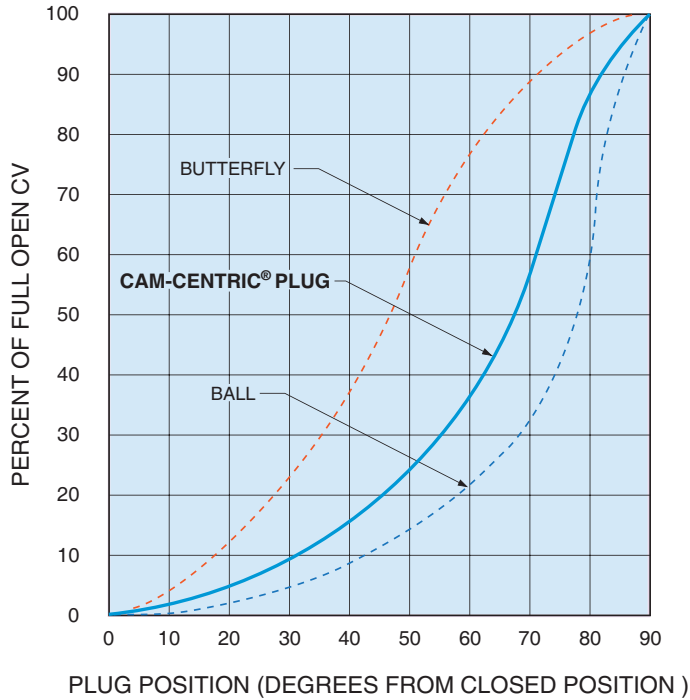

INHERENT PUMP CONTROL FLOW CHARACTERISTICS

To control pressure surges and provide good controllability, the flow characteristics of valves should be considered.

The graph at left shows the inherent flow characteristics at a constant ΔP for various valves.

The Plug Valve has an inherent flow characteristic similar to a ball valve. When installed in a pipeline, the plug valve will approximate a linear flow characteristic because the piping system pressure losses will shift the flow curve to the left. A linear installed flow characteristic will help control surges and provide a wide range of controllability.

Installations



Cam-Centric® Plug Valve with worm gear actuator and chainwheel



Cam-Centric® Plug Valve with Val-Matic Swing-Flex®



Cam-Centric® Plug Valve with worm gear actuator



Cam-Centric® Plug Valve with motor actuator



Cam-Centric® Plug Valve with Val-Matic dual body combination Air Valve



Cam-Centric® Plug Valve with worm gear actuator and extension stem

SCOPE

- 1.1 This specification covers the design, manufacture, and testing of 3 in. (75 mm) through 72 in. (1800 mm) 100% Port Eccentric Plug Valves suitable for water or wastewater service with pressures up to 175 psig (1204 kPa).
- 1.2 Plug Valves shall be quarter-turn, 100% port eccentric, with resilient encapsulated plug.

STANDARDS AND APPROVALS

- 2.1 Eccentric plug valves shall be designed, manufactured and tested in accordance with American Water Works Association Standard ANSI/AWWA C517.
- 2.2 All Plug Valves shall be certified Lead-Free in accordance with NSF/ANSI 372.
- 2.3 Manufacturer shall have a quality management system that is certified to ISO 9001 by an accredited, certifying body.

CONNECTIONS

- 3.1 Flanged valves shall have flanges with drilling to ANSI B16.1, Class 125.
- 3.2 Mechanical Joint valves shall fully comply with ANSI/AWWA C111/A21.11.

DESIGN

- 4.1 Valves shall have port areas of not less than 100% of pipe area.
- 4.2 3 in. (75 mm) and larger valves shall have a valve seat that is a welded overlay of 95% pure nickel applied directly to the body on a pre-machined, cast seating surface and machined to a smooth finish.
- 4.3 3 in. (75 mm) and larger plug valves shall have shaft seals which consist of V-type packing in a fixed gland with an adjustable follower and removable shims under the follower flange to provide for adjustment and prevent over compression.
- 4.4 Permanently lubricated, radial shaft bearings shall be supplied in the upper and lower bearing journals to eliminate the need for grease fittings. Thrust bearings shall be provided in the upper and lower journal areas, except for threaded type which only have upper thrust bearings.
- 4.5 Both the packing and bearings in the upper and lower journals shall be protected by Buna-N shaft seals located on the valve shaft to minimize the entrance of grit into the bearing journal and shaft seal areas.

MATERIALS

- 5.1 Valve bodies and covers shall be constructed of ASTM A126 Class B cast iron for working pressures up to 175 psig (1204 kPa). The words "SEAT END" shall be cast on the exterior of the body seat end.
- 5.2 3 in. (75 mm) and larger plugs shall be of one-piece construction and made of ASTM A126 Class B cast iron or ASTM A536 Grade 65-45-12 ductile iron and fully encapsulated with resilient facing per ASTM D2000-BG and ANSI/AWWA C517 requirements.
- 5.3 Plug valves shall have radial shaft bearings constructed of self-lubricating Type 316 stainless steel. The thrust bearings shall be PTFE. Cover bolts shall be corrosion resistant with zinc plating.

ACTUATION

- 6.1 Valves 3 in. (75 mm) to 8 in. (200 mm) shall be equipped with a 2 inch square nut for direct quarter turn operation with a hand lever. The packing gland shall include a friction collar and an open position memory stop. The friction collar shall include a nylon sleeve to provide friction without exerting pressure on the valve packing.
- 6.2 When specified, valves 3 in. (75 mm) and larger shall include a totally enclosed and sealed worm gear actuator with position indicator (above ground service only) and externally adjustable open and closed stops. The worm segment gear shall be ASTM A536 Grade 65-45-12 ductile iron with a precision bore and keyway for connection to the valve shaft. Bronze radial bearings shall be provided for the segment gear and worm shaft. Alloy steel roller thrust bearings shall be provided for the hardened worm.
- 6.3 All gear actuators shall be designed to withstand, without damage, a rim pull of 200 lb. on the hand wheel and an input torque or 300 ft-lbs. for nuts.
- 6.4 Buried service actuators shall be packed with grease and sealed for temporary submergence to 20 feet of water. Exposed worm gear shafts shall be stainless steel.

OPTIONS

- 7.1 The interior and exterior of the valve shall be coated with an NSF/ANSI 61 approved fusion bonded epoxy.
- 7.2 Available linings include rubber for abrasive or corrosive fluids and glass for a smooth, non-stick surface.

MANUFACTURE

- 8.1 Manufacturer shall demonstrate a minimum of ten (10) years' experience in the manufacture of plug valves. When requested, the manufacturer shall provide test certificates, dimensional drawings, parts list drawings and operation and maintenance manuals.
- 8.2 The exterior of the valve for above ground service shall be coated with a universal alkyd primer. Valve exterior for buried service shall be coated with an epoxy coating.
- 8.3 Valve shall be marked with the Serial Number, Manufacturer, Size, Cold Working Pressure (CWP) and the Direct and Reverse Actuator Pressure Ratings on a corrosion resistant nameplate.
- 8.4 Plug Valves shall be Series #5600F or #5700F as manufactured by Val-Matic Valve and Mfg. Corporation, Elmhurst, IL. USA or approved equal.



Ener•G® Ball Valves

VAL-MATIC®



AWWA
Rubber Seated
Ball Valves



Meets AWWA C507
NSF/ANSI 61 & 372 Certified

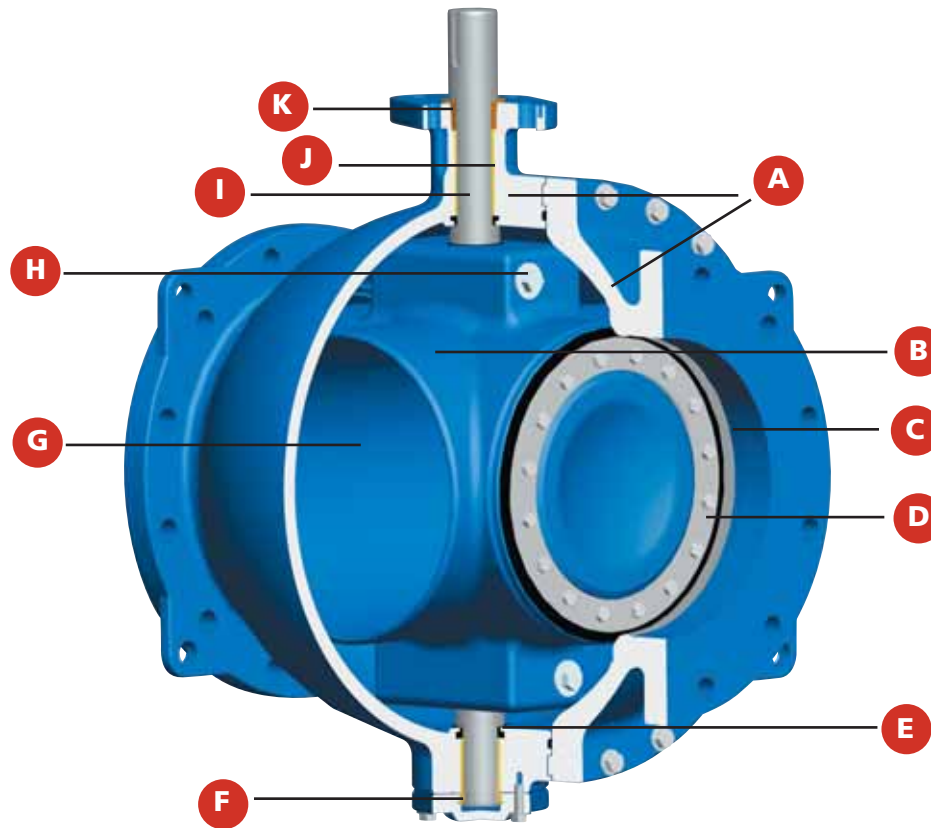

A. Body

The valve body consists of a main body section and end piece. The body design includes integral support legs and fully complies with AWWA Standard C507.

B. Ball

In the open position, the Ball provides a 100% clear flow, unobstructed circular opening. As the ball turns through its 90° travel, it provides a self-flushing (cleaning) action to the valve cavity between the body and ball. When fully closed, drop tight seating is provided.

C. Body Seat

Type 316 Stainless Steel provides extended life and a corrosion free mating surface for the resilient seat retained on the quarter turn ball.

D. Resilient Seating System

Tri-Loc™ Seating System with over 40 years of proven dependability is easily adjusted and field replaceable. All seat-retaining components are Type 316 Stainless Steel.

E. Grit Guard™ Seals

Grit Guard™ seals have been protecting Val-Matic valve bearings in raw sewage application with proven reliability for over 25 years.

F. Thrust Bearing Assembly

The thrust bearing is adjustable and pre-set at the factory.

G. FBE Coating

All valves are provided with fusion bonded epoxy which provides the highest level of corrosion protection and smooth flow surfaces for low headloss.

H. Taper Pins

Stainless steel taper pins provide over 40 years of proven dependability. The taper pin design locks the ball to the shaft and utilizes a Type 316 stainless steel bolt to maintain the lock during severe service.

I. Shafts

Large diameter stainless steel shafts are sized to provide maximum wear resistance with minimum stress during the most severe service conditions.

J. Shaft Sleeve Bearings

The teflon-lined shaft bearings provide low friction and high wear resistance.

K. Shaft Seal

The shaft seal is self-adjusting/wear compensating V-Type packing. The packing is field replaceable without removal of the valve from the line or valve disassembly.

With over 50 years of combined Ball Valve knowledge in the areas of Engineering, Manufacturing, Application and Design, the Val-Matic Ener•G® AWWA Rubber Seated Ball Valve has proven and preferred design features and advanced technology that only Val-Matic experience can provide. The Val-Matic Ener•G® Ball Valve is designed for tight seating, long life and energy savings.

Tight Seating

The resilient seat is based on technology with proven field use for over 40 years. Both single and double-seated valves are available for sealing in one or two directions. When fully open, the resilient seat is completely out of the flow stream.

Structural Integrity

The valve body is built with a main section and an end piece that are connected with precision registers and o-ring seals to withstand the rigors of pipeline service.

Tri-Loc™ Seat Retention System

Proven dependability since 1971, the Tri-Loc™ seat retention system provides positive mechanical retention of the valve seat while allowing easy adjustment or replacement. The seat is secured by three methods: clamp force, through-bolting and opposing registers in the ball and the seat retaining ring. Clamp force is provided by tightening nylok cap screws. These same screws provide through-bolting seat retention by passing through the precision molded holes in the resilient seat. Finally, molded shoulders in the seat are captured by registers and serrations in the ball and the retaining ring preventing outward movement of the seat.

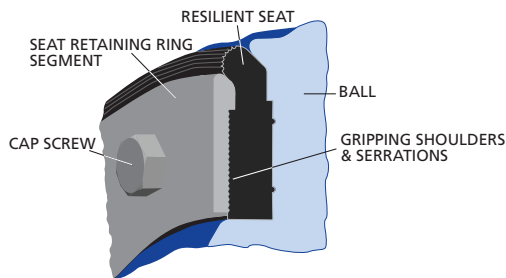

Energy Savings

In these times of conservation and "Green" design, there is no better valve than the Val-Matic Ener•G® AWWA Ball Valve. When fully open, the valve provides 100% clear flow area equal to the valve size. Hence, the valve headloss is equal to an equivalent length of pipe and will represent a significant savings in pumping costs.

Proof of Design Tested

The Val-Matic Ener•G® Ball Valve is certified to rigorous pressure and cycle proof of design tests per

AWWA C507. The valves were full-scale flow tested and operated at velocities exceeding 40-ft/sec at an independent laboratory.

Fusion Bonded Epoxy Coating

All Val-Matic Ener•G® Ball Valves are coated inside and out with NSF 61 fusion bonded epoxy per AWWA C550. The valve and its components are specifically designed for continuous uninterrupted fusion bonded epoxy coating. The interior and exterior are coated with fusion bonded epoxy for long life.

Proven Actuation

Val-Matic traveling nut actuators have been proven in rigorous field installations for over 40 years. Advances in design include ductile iron housings and levers, 450 ft-lb stops, **exclusive** externally adjustable closed stops and fully sealed housings. Traveling nut actuators can be fitted with stainless steel or non-metallic cylinders for hydraulic actuation.

Serviceability

If repairs become necessary, the valve is designed for easy field maintenance and repair. The shaft seal incorporates self-adjusting V-type packing, which is easily replaced in the field without removal from the line. Adjustment of the resilient seat is easily performed with a hand wrench. No two-part epoxy, hypodermic needles or pressure pots are required. The seat can be replaced with the valve in line.

Designed for Wastewater Service

The Ball Valve's clear flow path makes it ideal for wastewater service. However, Val-Matic takes additional steps to ensure its performance in wastewater by providing Grit Guard™ seals and a self-flushing action. The grit seals provide a seal between the shaft and body. These seals protect the body from corrosion and the bearings from premature wear. The ball is designed so there is a significant flushing action between the body and outside of the ball to prevent clogging in wastewater service.

Advanced Technology

Incorporating the latest in valve technology assures a high-quality valve that will provide long service. The design process utilized Solid Modeling and Finite Element Analysis (FEA) of the key structural components. Flow and torque data was derived from flow tests, mathematical models and Computational Fluid Dynamics (CFD). Manufacturing technology uses automated process control in the foundry and ISO 9001 controlled manufacturing processes. Every valve is tested in accordance with AWWA C507 on automated hydraulic test rigs with calibrated gauges.

Ratings/Construction

PRESSURE RATINGS

MAXIMUM PRESSURE RATINGS			
SERIES	CONFIGURATION	AWWA Class	CWP (psig)
4100	ANSI 125# Gray Iron - Single Seat	150D	150
4200	ANSI 125# Gray Iron - Double Seat	150D	150
4300	ANSI 250# Ductile Iron - Single Seat	300D	300
4400	ANSI 250# Ductile Iron - Double Seat	300D	300
4500	ANSI 150# Ductile Iron - Single Seat	250D	250
4600	ANSI 150# Ductile Iron - Double Seat	250D	250

MATERIALS OF CONSTRUCTION

COMPONENT	STANDARD	OPTIONAL
Body Class 150D	ASTM A126 Class B	-
Body Class 250D/300D	ASTM A536 Gr 65-45-12	-
Ball Class 150D	ASTM A126 Class B	-
Ball Class 250D/300D	ASTM A536 Gr 65-45-12	-
Shaft Class 150D	ASTM A276 Type 304	Type 316
Shaft Class 250D/300D	ASTM A563 Type 630	-
Resilient Seat	EPDM	Buna-N
Body Seat and Hardware	Type 316 Stainless Steel	-
Shaft Bearings	Teflon-Lined, Fiberglass Backed	Bronze
Grit Seal	Molythane	-
V-Packing	Buna-N	-

Headloss Chart

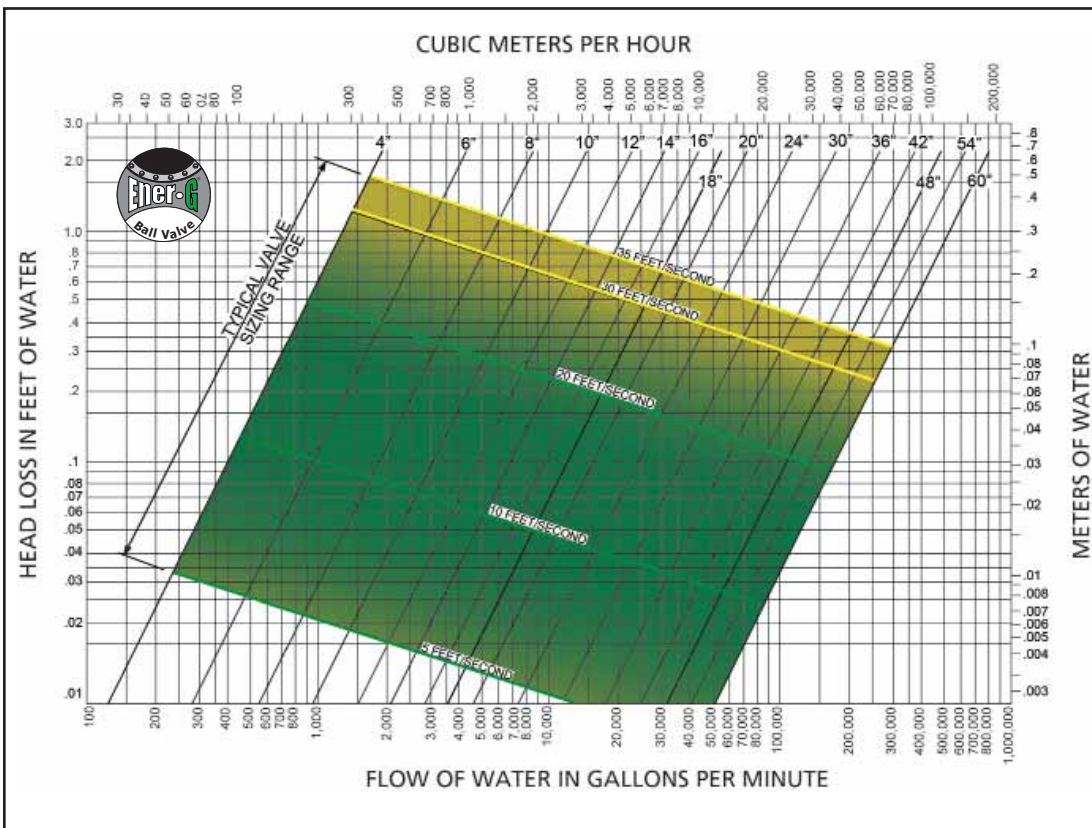

Flow Coefficients	
Size	Cv
4"	1,910
6"	4,310
8"	8,520
10"	14,700
12"	22,800
14"	30,500
16"	42,700
18"	56,100
20"	70,500
24"	106,000
30"	172,000
36"	257,000
42"	369,000
48"	480,000
54"	620,000
60"	775,000

Energy Cost Savings

An important characteristic of valves in water pumping systems that is often overlooked is the valve's ability to minimize energy consumption. Common flow coefficients for various valves used in pumping systems are shown below. Since Cv represents the flow through a valve with a 1 psi pressure drop, we can see that a Ball Valve provides the lowest headloss characteristics.

12 in. Valve Flow Data			
Type of Valve	Cv	ΔH	40-Year Energy Cost*
Swing Check & Weight	3,395	3.58	\$49,900
Globe-Style Control Valve	1,800	12.75	\$177,800
Butterfly Valve	6,550	0.96	\$13,400
Eccentric Plug Valve	4,750	1.81	\$25,300
Ener•G® AWWA Ball Valve	22,800	0.07	\$936

* Assumes 50% usage over 40 years, \$.08/kw-hr, 12 ft/sec velocity, 0.8 efficiency

The headloss from valves can be converted into the energy cost related to the pumping electrical power needed to overcome the additional headloss from the valve with the equation:

$$A = (1.65 Q \Delta H S_g C U) / E$$

Where:

- A = annual energy cost, dollars per year
- Q = flow rate, gpm
- ΔH = head loss, ft. of water
- Sg = specific gravity, dimensionless
- C = cost of electricity, \$/kW-h
- U = usage, percent
- E = efficiency of pump/motor set

The table shows that the Val-Matic Ener•G® AWWA Ball Valve with its low energy cost pays for itself over its life. It consumes less than 1% the energy of a Globe-Style Control Valve. Larger systems and systems operating at higher velocities will provide even greater savings.

If your goal is to design a "Green" pumping system, the Val-Matic Ener•G® Ball Valve is the valve of choice.

Flow Characteristics

Inherent Flow Characteristics

In addition to being the best selection for energy savings, the Val-Matic Ener•G® Ball Valve is the best selection for surge control. Its inherent flow characteristics are highly suited to control flow and pressure.

Some valves like Globe and Plug will linearly reduce the flow rate in proportion to the movement of the closure member. Quick Opening valves, such as Gate Valves, only affect the flow during the last 30% of their closure. Equal percentage valves, like the Ball Valve, uniformly change the flow rate during the full travel.

The graph below provides the Inherent Flow Characteristics of various types of valves. The data is expressed in terms of flow coefficient (Cv) at various percents of the valve's position. The most desirable flow characteristic for surge control is equal percentage as provided by the Val-Matic Ener•G® Ball Valve.

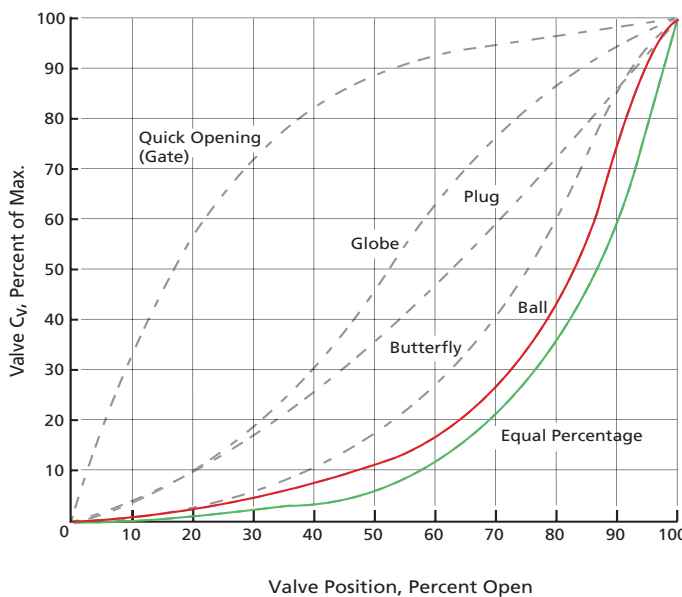

Valve Inherent Flow Characteristics



Pump Control Ball Valve

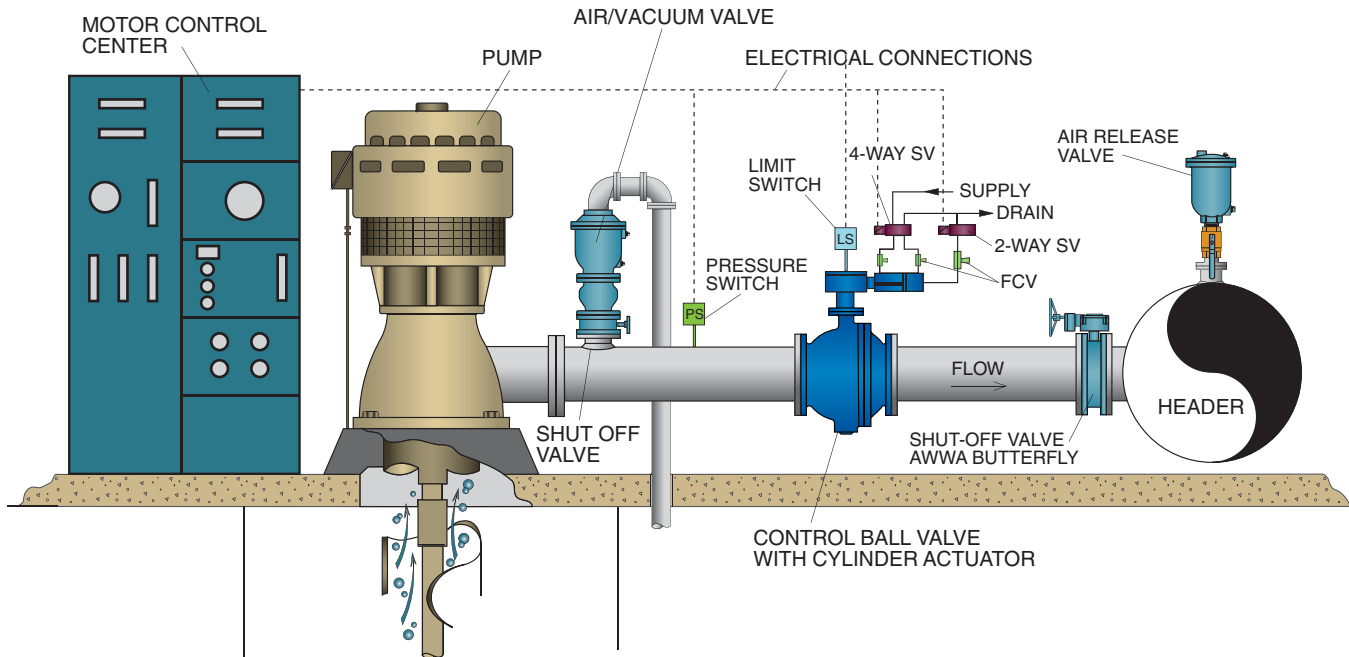

Typical Pump Control System
(Single or Multiple Pump)

Pump Control Ball Valves

For pumping systems where surge control is critical and energy savings are important, a pump control ball valve is preferred. The valve is wired to the pump controls and provides adjustable opening and closing times in excess of the system critical surge period. Unlike check valves, the pump control ball valve's speed of operation is not affected by line flow or pressure conditions. Stable operating times are essential in controlling surges in pumping systems. A Val-Matic Ener•G® Ball Valve is the ideal pump control valve for pumping systems. Its equal percentage flow characteristics, rugged AWWA construction and negligible headloss make it the preferred choice.

Sequence of Operation

When the pump is started and pressure builds, a pressure switch (PS) located on the pump discharge pipe signals the Ball Valve to open. During shutdown, the valve is signaled to close while the pump continues to run. When the Ball Valve nears the closed position, a limit switch (LS) located on the valve will stop the pump. After a power outage or pump trip, the flow will rapidly reverse. The Ball Valve must close rapidly to prevent backspinning the pump and rapid depletion of a hydro-pneumatic surge tank when utilized.

Cylinder Actuator Control

The Ener•G® Ball Valve is equipped with a hydraulic cylinder actuator. The cylinder can be powered with pressurized water from the line or from an independent oil hydraulic power system. Mounted on the valve or in a floor-mounted panel are the hydraulic controls electrically wired to the pump controls. Solenoid valves (SV) direct the operating medium to the cylinder ports to cycle the valve. The speed of opening and closing is controlled by independently adjustable flow control valves (FCV). The valve hydraulic controls are equipped with a bypass line to send the controlled cylinder flow around the normal flow control valve and through an alternate fast-closing flow control valve.

Motor Actuator Control

Alternatively, when a clean water supply is not available to power a cylinder actuator, such as a lift station application, the Ball Valve can be supplied with a motor actuator. The operating times are adjustable in the field with special actuator motor controls. To protect the pump and system on power failure, the valve can either be supplied with a battery backup system or a Surgebuster® Check Valve. The Surgebuster® provides low headloss and non-slam characteristics.

Hydraulic Panel

The Val-Matic hydraulic control panel uses the highest quality components available and is designed to reliably operate the pump control ball valve with water or oil supply. Unlike a motor-operated control valve, the control panel allows field adjustment of the valve operating times so that the valve can be timed to match the surge characteristics of the piping system. The controls are panel mounted and pre-wired to a terminal strip in a NEMA 4X junction box for easy installation. An optional NEMA 4X enclosure is available to secure and protect the equipment in the harshest of environments.

There are four pressure connections to the cabinet: Supply, Drain, Open, and Close. The supply connection is equipped with an isolation valve and pressure gauge for ease of troubleshooting the control system. The supply and drain headers are controlled by brass two-way normally-open solenoid valves assembled with rigid brass pipe and heavy duty, non-corrosive, quick connect style hose and fittings. They provide rapid valve closure upon electrical power failure to minimize backspinning of the pump. The emergency closure rate is adjustable in the 10-30 second range by the balancing valve in the bottom header. The normal open and closing of the pump control valve is controlled by the brass four-way solenoid valve and independently adjustable multi turn flow control valves. The flow control valves allow independent control of the operating times in the 30-600 second range.

The solenoid valves are wired to a NEMA 4X junction box using liquid-tight conduit. The solenoid valve wires are terminated inside of the junction box with terminals. Installation of the system is easy and fast since only one conduit connection is needed to connect the panel to the pump controls.

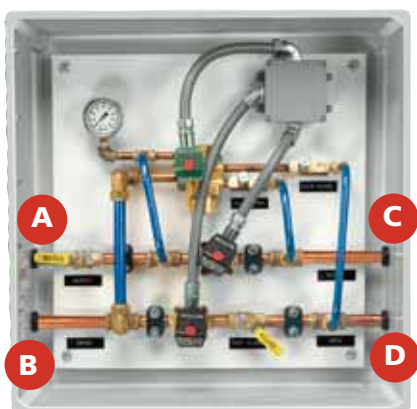

Hydraulic Panel

- A. Supply Pressure
- B. Drain
- C. Pressure to Close
- D. Pressure to Open

Electric Panel

The Val-Matic electrical control panel uses the highest quality components available and is designed to work with the hydraulic panel in controlling and monitoring the operation of the pump control ball valve. The relays and timers are panel mounted and pre-wired to a terminal strip in a hinged NEMA 4X enclosure for easy installation and to protect the equipment in the harshest of environments.

The control panel includes internal plug-in type Run and Stop Relays to control the operation of the pump. An adjustable Timing Relay monitors the operation of the system and automatically shuts down the pump if the pump does not build pressure or the valve fails to open. Transformer-type Pilot Lights are used to provide safe indication. The RUN, OPEN, and CLOSE pilot lights indicate valve and pump operation. The STOP light indicates that an alarm condition exists and the pump is locked out. Once the alarm condition is resolved, the RESET button is pressed to activate the system. An EMERGENCY STOP button is provided to stop the pump at the valve location. When the button is pressed, the valve closes at the normal rate, and automatically shuts off the pump when the closed limit switch is tripped.



Electric Panel

Exclusive Val-Matic Control System Features for Hydraulic and Electric Panels

- Waterproof and corrosion-resistant enclosures
- Rigid brass pipe with heavy duty hose and fittings
- Supply line with isolation valve and pressure gauge
- Reliable ASCO solenoid valves and vernier flow control valves
- Heavy-Duty switches and transformer pilot lights

Oil Accumulator Systems

Oil Accumulator Systems include an electrical panel, ASME pressure tank, dual oil pumps and dual air compressors are skid-mounted and supply a safe and steady 80-125 psig oil supply pressure to the pump control valve, even after power failure.



Oil Accumulator System

Installation Dimensions

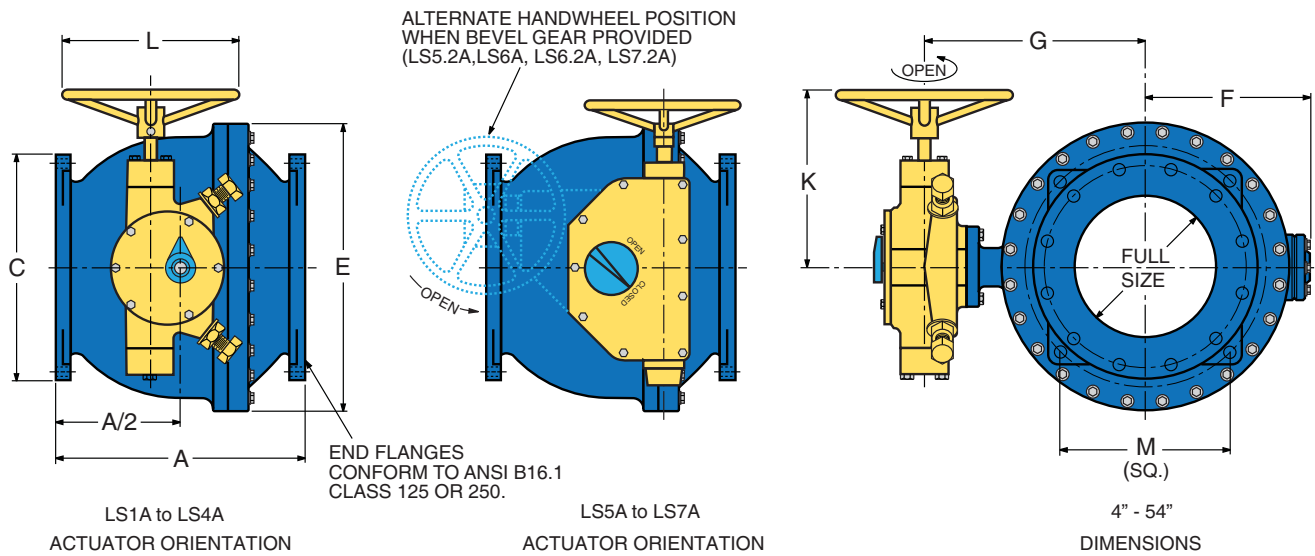

Val-Matic's traveling nut manual actuators are designed to specifically match the torque characteristics of the Val-Matic Ener•G® Ball Valve and are built in accordance with AWWA Standard C507 for Ball Valves. The traveling nut actuator provides characterized closure which allows the valve to slowly close during the last half of travel to reduce pipeline surges. Val-Matic actuators have the exclusive features of externally adjustable stops rated to 450 ft-lbs of input torque.

Dimensions in Inches

Valve Size	AWWA Class	Actuator Size*	No. of Turns	A	C	E	F	G	K	L	M
4	150	LS-1A	15	12.38	9.00	11.75	7.25	10.25	9.38	8	7.11
	300	LS-1A	15	13.00	10.00	11.75	7.25	10.50	9.38	8	7.87
6	150	LS-2.2A	20	15.75	11.00	14.75	8.50	11.38	11.25	12	8.57
	300	LS-2A	20	16.00	12.50	15.00	9.50	12.38	11.25	12	9.63
8	150	LS-2A	20	18.00	13.50	17.88	10.38	13.63	11.25	12	10.34
	300	LS-3.2A	35	18.00	15.00	18.13	11.75	16.13	13.88	12	11.49
10	150	LS-3A	35	19.50	16.00	21.13	12.38	16.00	13.88	12	12.20
	300	LS-3A	35	21.13	17.50	21.63	13.88	17.50	13.88	12	13.34
12	150	LS-3A	35	21.00	19.00	24.25	14.38	18.13	14.88	16	14.32
	300	LS-3A	35	24.00	20.50	24.50	16.50	20.25	14.88	16	15.55
14	150	LS-3A	35	26.25	21.00	27.50	16.38	20.00	14.88	16	15.82
	300	LS-4A	50	27.75	23.00	27.75	18.75	22.63	19.88	24	17.32
16	150	LS-3A	35	27.00	23.50	30.63	18.63	22.25	14.88	16	17.59
	300	LS-4A	50	28.13	25.50	31.63	21.75	25.63	21.38	30	19.18
18	150	LS-4A	50	30.00	25.00	33.88	20.38	24.38	21.38	30	18.74
	300	LS-4A	50	31.00	28.00	34.50	23.63	27.63	21.38	30	20.94
20	150	LS-4A	50	32.00	27.50	36.75	21.88	25.75	21.38	30	20.50
	300	LS-5.3A	100	34.00	30.50	37.38	25.81	30.50	23.97	16	22.71
24	150	LS-5A	100	37.00	32.00	43.13	26.25	31.50	28.25	24	23.77
	300	LS-5A	100	42.75	36.00	43.63	30.88	36.13	28.25	24	26.78
30	150	LS-5.2A	255	46.00	38.75	52.44	31.03	35.50	20.13	16	28.55
	300	LS-5.2A	255	50.25	43.00	53.44	37.25	42.50	20.13	24	39.99
36	150	LS-5.2A	255	54.00	46.00	62.00	38.13	43.38	19.50	24	33.85
	300	LS-6A	425	54.00	50.00	63.00	44.88	51.50	24.88	24	37.12
42	150	LS-6.2A	425	59.50	53.00	71.06	43.75	50.25	24.88	24	38.80
	300	LS-6.2A	425	61.00	57.00	72.56	51.50	58.00	24.88	30	42.07
48	150	LS-6.2A	425	72.00	59.50	79.69	49.50	55.63	24.88	30	43.39
	300	LS-7.2A	720	76.50	65.00	81.19	58.38	67.00	32.25	30	47.72
54	150	LS-6.2A	425	82.00	66.25	89.50	55.00	64.50	24.88	30	49.67
		LS-7.2A	720					67.00	32.25		

*Actuator sizes vary with flow and pressure conditions.

Installation Dimensions

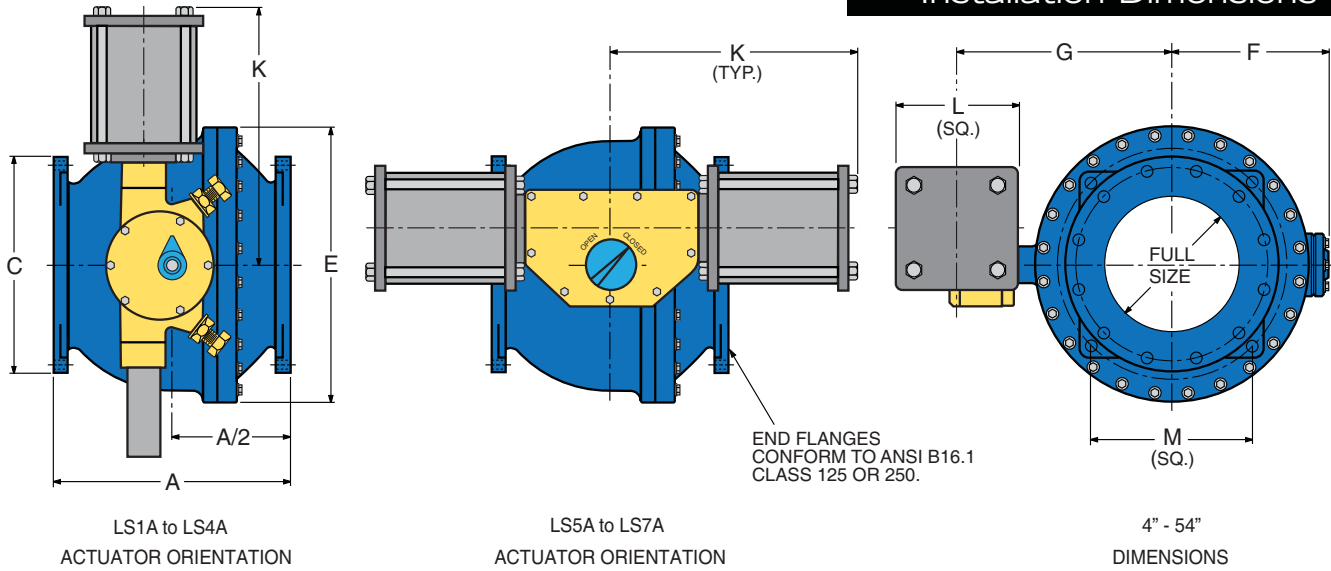

Val-Matic's traveling nut cylinder actuators provide reliable characterized closure and are designed and built in accordance with AWWA Standards C507 for Ball Valves and C541 for Hydraulic and Pneumatic Cylinder and Vane-Type Actuators for Valves and Slide Gates and feature externally adjustable closed stops for easy adjustment. The cylinder heads and barrels are constructed of stainless steel or non-metallic materials and include large NPT ports. The stainless steel piston is fitted with a wear strip for long and reliable seal life. The seals are suitable for air, oil or water supply media to 150 psig and are replaceable without removing the cylinder from the actuator unit.

Dimensions in Inches											
Valve Size	AWWA Class	Actuator Size*	Cylinder Bore	A	C	E	F	G	K	L	M
4	150	LS-1A	6	12.38	9.00	11.75	7.25	10.25	14.00	6.75	7.11
	300	LS-1A	6	13.00	10.00	11.75	7.25	10.50	14.00	6.75	7.87
6	150	LS-2A	6	15.75	11.00	14.75	8.50	11.00	14.00	6.75	8.57
	300	LS-2A	8	16.00	12.50	15.00	9.50	12.38	16.88	8.75	9.63
8	150	LS-2A	8	18.00	13.50	17.88	10.38	13.63	16.88	8.75	10.34
	300	LS-3A	10	18.00	15.00	18.13	11.75	16.13	24.38	10.88	11.49
10	150	LS-3A	10	19.50	16.00	21.13	12.38	14.88	18.38	10.88	12.20
	300	LS-3A	10	21.13	17.50	21.63	13.88	17.50	24.38	10.88	13.34
12	150	LS-3A	10	21.00	19.00	24.25	13.96	18.56	23.43	10.88	14.32
	300	LS-3A	12	24.00	20.50	24.50	16.50	20.25	24.38	12.88	15.55
14	150	LS-3A	12	26.25	21.00	27.50	16.38	20.00	24.38	12.88	15.82
	300	LS-3A	12	27.75	23.00	27.75	18.75	22.63	30.13	12.88	17.32
16	150	LS-3A	12	27.00	23.50	30.63	18.63	22.25	24.38	12.88	17.59
	300	LS-4A	14	28.13	25.50	31.63	21.75	25.63	31.63	15.00	19.18
18	150	LS-4A	12	30.00	25.00	33.88	20.38	24.38	30.13	12.88	18.74
	300	LS-4A	14	31.00	28.00	34.50	23.63	27.63	31.63	15.00	20.94
20	150	LS-4A	14	32.00	27.50	36.75	21.88	25.75	31.63	15.00	20.50
	300	LS-5.3A	14	34.00	30.50	37.38	25.81	30.50	43.44	15.00	22.71
24	150	LS-5A	14	37.00	32.00	43.13	26.25	31.50	42.19	15.00	23.77
	300	LS-5A	18	42.75	36.00	43.63	30.88	36.13	50.00	19.13	26.78
30	150	LS-5.2A	18	46.00	38.75	52.44	31.88	37.13	50.00	19.13	28.55
	300	LS-5.2A	18	50.25	43.00	53.44	37.25	42.50	50.00	19.13	31.99
36	150	LS-5.2A	18	54.00	46.00	62.00	38.13	43.38	50.00	19.13	33.85
	300	LS-6A	18	54.00	50.00	63.00	44.88	51.50	58.88	19.13	37.12
42	150	LS-6.2A	18	59.50	53.00	71.06	43.75	48.88	50.00	19.13	38.80
	300	LS-6.2A	24	61.00	57.00	72.56	51.50	58.00	61.38	25.13	42.07
48	150	LS-6.2A	24	72.00	59.50	79.69	49.50	55.63	61.38	25.13	43.39
	300	LS-7.2A	24	76.50	65.00	81.19	58.38	67.00	75.00	25.13	47.72
54	150	LS-7A	24	82.00	66.25	89.50	55.00	67.00	75.00	25.13	49.67

*Actuator sizes vary with flow and pressure conditions.

Installation Dimensions

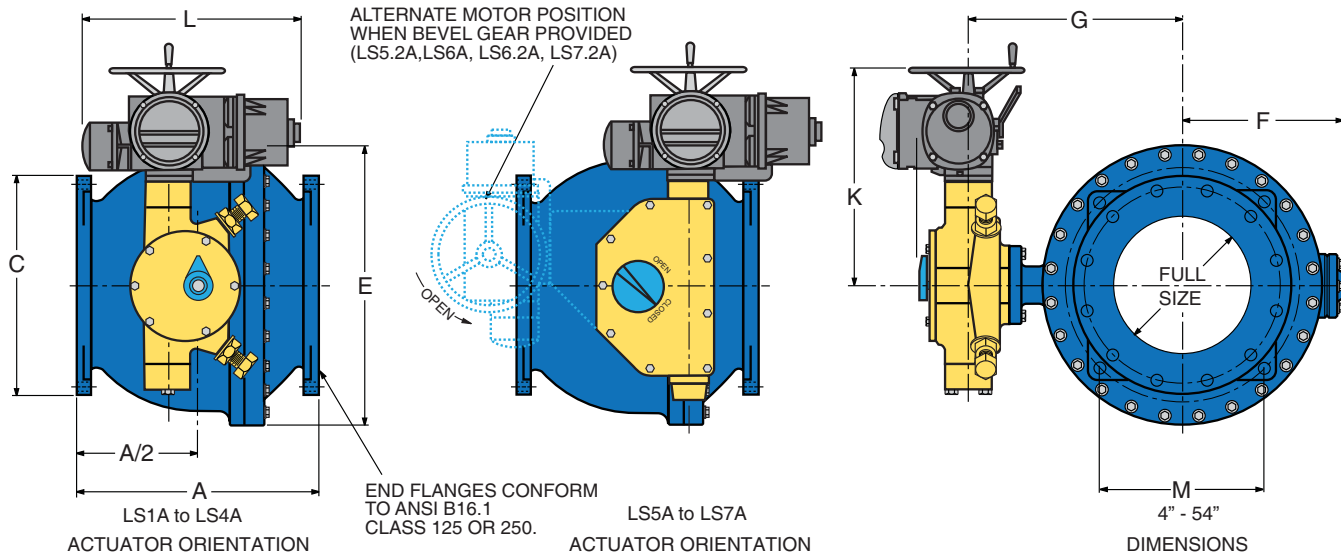

Val-Matic's traveling nut motor actuators are specifically designed to match the torque characteristics of the Val-Matic Ener•G® Ball Valve. The actuators are built in accordance with AWWA Standards C507 for Ball Valves and C542 for Electric Motor Actuators for Valves and Slide Gates and are equipped with externally adjustable stops for easy field adjustment. Motors are available to suit multiple speeds and voltages and are equipped with thermal overloads, torque switches and limit switches to protect the actuator and ball valve. A handwheel gear set with declutch is included to allow users to manually position the valve without electrical power.

Dimensions in Inches

Valve Size	AWWA Class	Actuator Size*	Motor Class	A	C	E	F	G	K	L	M
4	150	LS-1A	M01	12.38	9.00	11.75	7.25	9.56	15.77	23.00	7.11
	300	LS-1A	M01	13.00	10.00	11.75	7.25	10.81	15.77	23.00	7.87
6	150	LS-2A	M01	15.75	11.00	14.63	8.50	11.56	16.59	23.00	8.57
	300	LS-2A	M01	16.00	12.50	14.88	9.50	13.18	16.59	23.00	9.63
8	150	LS-2A	M01	18.00	13.50	17.75	10.38	13.25	16.59	23.00	10.34
	300	LS-3A	M02	18.00	15.00	18.00	11.75	15.68	21.21	26.10	11.49
10	150	LS-2A	M01	19.50	16.00	21.13	12.38	16.56	16.59	23.00	12.20
	300	LS-3A	M02	21.13	17.50	21.63	13.88	16.81	21.21	26.10	13.34
12	150	LS-2A	M01	21.00	19.00	24.13	14.38	17.94	16.59	23.00	14.32
	300	LS-3A	M02	24.00	20.50	24.63	16.50	20.63	21.21	26.10	15.55
14	150	LS-3A	M02	26.25	21.00	27.50	16.38	21.31	21.21	26.10	15.82
	300	LS-4A	M02	27.75	23.00	27.75	18.75	22.25	22.96	26.10	17.32
16	150	LS-3A	M02	27.00	23.50	30.60	18.63	23.25	21.21	26.10	17.59
	300	LS-4A	M02	28.13	25.50	31.44	21.75	26.38	22.96	26.10	19.18
18	150	LS-4A	M02	30.00	25.00	33.88	20.38	24.00	22.96	26.10	18.74
	300	LS-4A	M02	31.00	28.00	34.50	23.63	26.44	22.96	26.10	20.94
20	150	LS-4A	M02	32.00	27.50	36.75	21.88	27.50	22.96	26.10	20.50
	300	LS-5A	M03	34.00	30.50	37.38	25.81	29.81	31.03	26.10	22.71
24	150	LS-5A	M02	37.00	32.00	43.13	26.25	31.13	31.03	26.10	23.77
	300	LS-5A	M02	42.75	36.00	43.63	30.88	34.50	31.03	26.10	26.78
30	150	LS-5.2A	M02	46.00	38.75	52.44	31.03	36.19	25.55	26.10	28.55
	300	LS-5.2A	M02	50.25	43.00	53.44	37.25	41.38	25.55	26.10	31.99
36	150	LS-5.2A	M02	54.00	46.00	62.00	38.13	42.94	25.5	26.10	33.85
	300	LS-6A	M03	54.00	50.00	63.00	44.88	49.81	31.50	26.10	37.12
42	150	LS-6.2A	M03	59.50	53.00	71.06	43.75	49.31	31.50	26.10	38.80
	300	LS-6.2A	M03	61.00	57.00	72.56	51.50	57.13	31.50	26.10	42.07
48	150	LS-6.2A	M03	72.00	59.50	79.69	47.62	55.56	31.50	26.10	43.39
	300	LS-7.2A	M03	76.50	65.00	81.19	56.49	64.44	39.50	26.10	47.72
54	150	LS-7.2A	M03	82.00	66.25	89.50	55.00	65.00	39.50	26.10	49.67

*Actuator sizes vary with flow and pressure conditions.

SCOPE

- 1.1 This specification covers the design, manufacture, and testing of 4" - 54" AWWA Class 150 and 300 Rubber Seated Ball Valves.

STANDARDS AND APPROVALS

- 2.1 The valves shall be designed, manufactured and tested in accordance with American Water Works Association Standard AWWA C507.
- 2.2 The valves shall be certified Lead-Free in accordance with NSF/ANSI 372.
- 2.3 Manufacturer shall have a quality management system that is certified to ISO 9001 by an accredited, certifying body.

DESIGN

- 3.1 The valve shall be constructed with a two-piece body rated for 150 or 300 psi with end flanges in full conformance with ANSI B16.1 Class 125 or Class 250. The main body section and end piece shall contain integrally cast support feet and lifting lugs.
- 3.2 The valve port shall be a 100% clear bore equal to the nominal valve size with no seat hardware in the flow stream when fully open. The ball shall be self-flushing when in intermediate positions for wastewater service.
- 3.3 Double (or single) resilient seats shall provide drop-tight service and shall be located on the ball and mechanically retained with a stainless steel retaining ring and stainless steel nylok cap screws, which shall pass through both the resilient seat and the retaining ring. The retaining ring shall be continuous or investment cast with overlapping sections, serrated grooves and shoulders. The resilient seat shall be field adjustable and replaceable without removing the valve from the pipeline and mate to a continuous 316 stainless steel body seat ring.
- 3.4 Valve shafts shall be inserted into blind hubs in the ball and locked to the ball with taper pins retained with stainless steel jam bolts. The shaft shall be sealed with resilient grit seals in the body bores.
- 3.5 Teflon-lined, fiberglass-backed sleeve bearings shall be located in the body hubs.
- 3.6 An adjustable thrust bearing shall be provided to center the ball in the body.
- 3.7 Shaft seals shall be of the V-type and shall be replaceable without removal of the valve from the line or the shaft from the valve.

ACTUATION

- 4.1 Manual actuators shall be of the traveling nut design with characterized closure per AWWA C507 and equipped with externally adjustable closed position stops capable of withstanding 450 ft-lbs. Actuators shall be lubricated with EP-2 grease and fully enclosed in an iron housing sealed against the entry of water.
- 4.2 Cylinder actuators shall be traveling nut with characterized closure and sized to position the valve with an air, water or oil supply pressure of 80-150 psi and built in accordance with AWWA C541. The rotating mechanism will consist of a lever and traveling nut directly connected to the cylinder rod. The cylinder rod, heads and barrel shall be constructed of stainless steel or non-metallic material for water service. Rod and piston seals shall be of the self-adjustable, wear-compensating type. The piston shall be one piece with a wear strip.
- 4.3 Motor actuators shall be furnished in accordance with AWWA C542 for Power Actuators and factory tested on the production ball valve. The motor unit shall be mounted to a self-locking traveling nut actuator with characterized closure and externally adjustable closed stop. The motor actuator assembly shall be designed for open/close service with a minimum operating time of 60 sec. The motor unit shall be furnished with a position indicator, independently adjustable, 15-amp limit switches, and adjustable torque sensors to protect the valve indicator. A handwheel with a declutch lever shall be provided so that the handwheel does not rotate during electrical operation. Motors shall be sized with a 1.5 safety factor and a power supply of 230/460V, three phase, 60 Hz AC. Electrical operation shall include Local-Off-Remote selector switch, Local Open/Close push buttons and position indication lamps.

MANUFACTURE

- 5.1 Valve interiors and exteriors shall be coated with an NSF/ANSI 61 certified fusion bonded epoxy in accordance with AWWA C550.
- 5.2 Rubber Seated Ball Valves shall be Val-Matic® Series #4000 as manufactured by Val-Matic® Valve & Mfg. Corporation, Elmhurst, IL. USA.



*QuadroSphere® Trunion
Mounted Ball Valves*



VAL-MATIC®



QuadroSphere®
Trunnion Mounted
Ball Valves
Ring Master®
Seating System



API 6D Certified
API 607 Certified

The QuadroSphere® Ball Valve has over 20 years of proven performance in numerous applications in the power, oil & gas, refinery, mining, steel, chemical, geothermal and petrochemical industries.

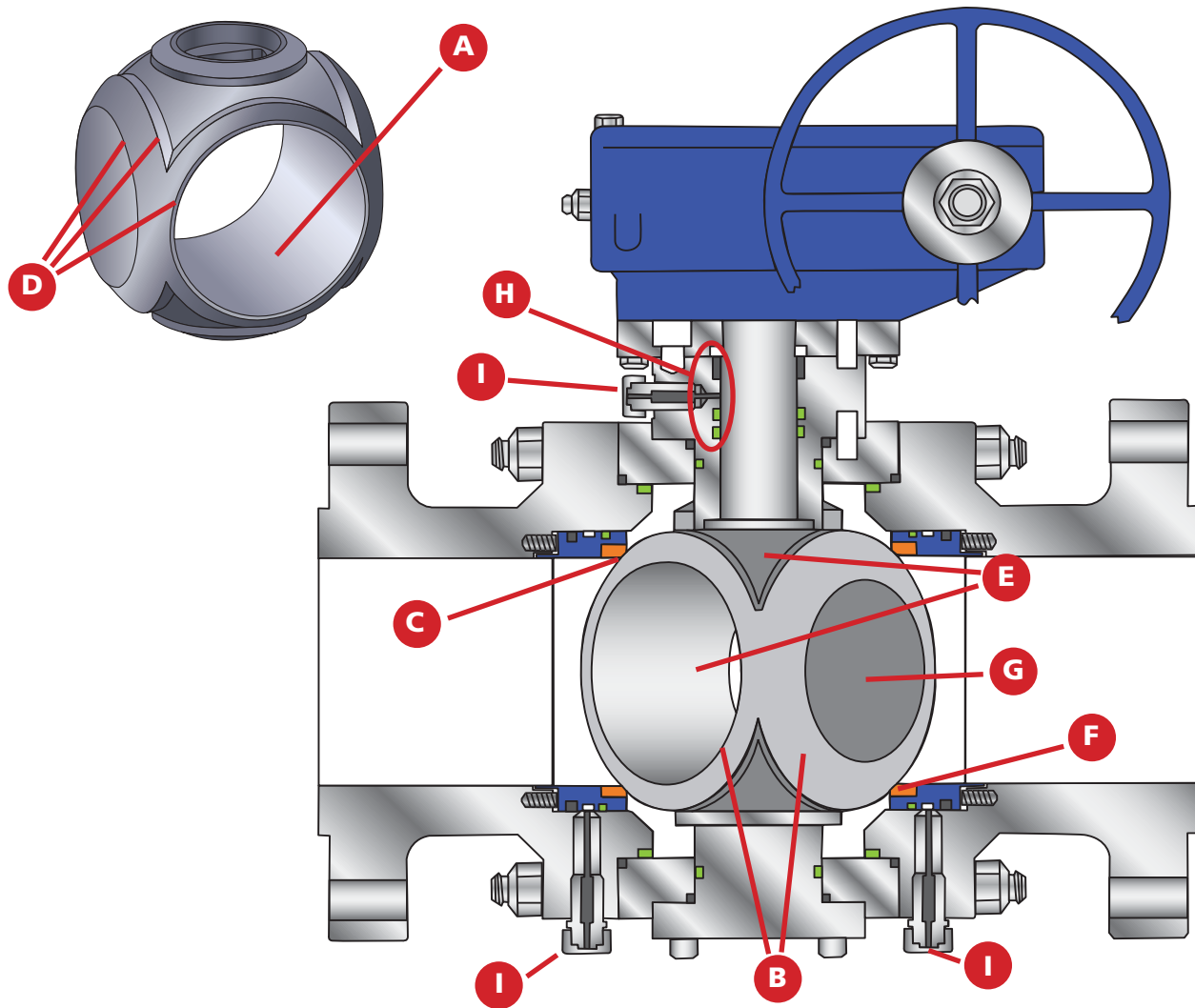

Exclusive QuadroSphere® Advantages

A. QuadroSphere® Ball

Unique contoured full port ball adds 4 additional flow paths: over, under and around the sides for self-flushing the ball cavity.

B. Wear Resistance

Reduced ball to seat contact creating up to 70% less wear.

C. Low Torque

Minimal ball to seat contact when opening or closing lowers the running torque.

D. Self-Cleaning Action

Four recessed surfaces on the ball provide lipped edges for scraping the seats clean to avoid the build-up of solids and scale.

E. Multiple Flow Paths

Reduces cavitation and minimizes velocity spikes, reducing wear and erosion.

F. Protected Seating

Seat surfaces are out of the flow path and fully protected from direct flow.

G. Hardened Ball

Ground and polished hard chrome plated stainless steel ball provides low operating friction and abrasion resistance.

H. Stem Seals

Double O-ring stem seals are backed up by graphite packing compression rings as standard.

I. Injection Fittings

In the event of damage to the seat insert or stem seals, sealant can be injected to temporarily seal the valve until repairs can be made.

QuadroSphere® Ball

The QuadroSphere® Ball is not a typical ball design. Surfaces of the full port ball that are non-essential to sealing have been recessed in all 4 quadrants. The surfaces of the ball that have been recessed create additional flow paths allowing the flow and particulates to move freely above, below and around the sides of the ball when moving from closed to open position. Seat ring contact to the ball has minimal contact area, which reduces wear and operating torques, due to less friction. The recessed surfaces on the ball also provide lipped edges that wipe the seat surfaces clean during opening and closing to avoid particulate buildup. The ball has two sets of seating surfaces to provide shut off in the fully closed position and protect the seats in the fully open position.

Self-Cleaning Features

Typical ball valves allow liquids and solids to be trapped within the body/ball cavity, resulting in solids accumulating around the ball that can cause clogging and/or damage to the seating surfaces. When the QuadroSphere® Ball cycles, its unique 4 recessed surfaces allow solids to be flushed from the body/ball cavity to prevent buildup of the solids around the back of the seat rings and bearings, Figure 1.

Protected Seating Surfaces

The QuadroSphere® Ball protects its seats from media velocity by minimizing contact of the upstream seating surfaces during cycles. When the QuadroSphere® Ball closes, the media applies pressure to the upstream seat ring pushing it against the ball's upstream sealing surface for leak tight performance.

Lower Torque Requirements

The contour machining of the ball substantially reduces the ball to seat surface contact. This creates less resistance during cycles, lowering the torque to operate the QuadroSphere® Ball Valve.

Anti-Blowout Stem

The stem has an integral collar to prevent the stem from being ejected from the valve, while under line pressure per API 6D and ASME B16.34 standards.

Stem Seals & Bearings

The area around the stem seals and bearings is flushed clean each time the valve cycles from open to close. This helps to eliminate solids build up, that can damage the seals and bearings during operation, Figure 1.

Body & Ball Construction

The QuadroSphere® body and ball are forgings to provide superior surface finish and structural integrity. Forgings prevent defects, normally associated with castings such as pitting, sand inclusions, porosity and any need for weld repairs.

70% Less Wear

Unlike typical ball valves the QuadroSphere® Ball maintains a fraction of the resistance across the seating surfaces when cycling, reducing wear up to 70% and improving the performance life of the ball and seats. As the ball cycles, 4 additional flow paths (over, under and around both sides) are created by the recessed surfaces, eliminating localized, high velocity impingement upon the downstream seat as with typical ball valves.

Industry Compliance

The QuadroSphere® Ball Valve has undergone tests to demonstrate its unique abrasion resistant ball design in severe applications. With over 20 years of proven performance, the QuadroSphere® Ball Valve solves the most difficult application problems in many industries. The QuadroSphere® Ball Valve is designed in accordance with API 6D and ASME B16.34 requirements. The valve carries the API 6D Monogram and has been certified to API 607, Fire Test standard. The QuadroSphere® meets standards: API, ASME/ANSI, BS, ISO, MSS and NACE.

QuadroSphere® allows debris to be flushed from the valve body.

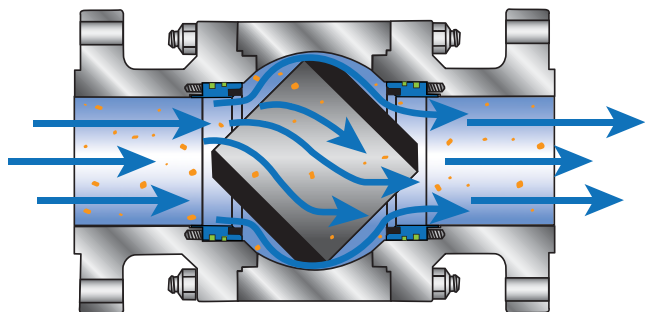

Typical Ball Valve allows debris and solids to accumulate.

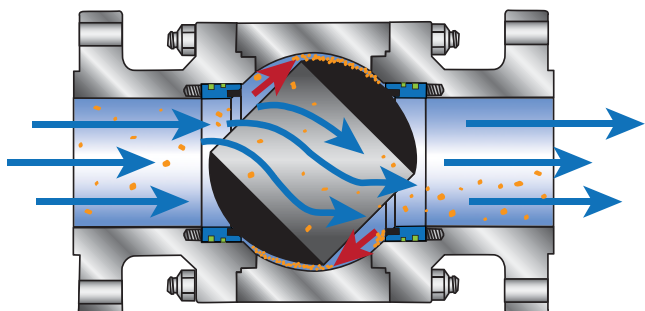
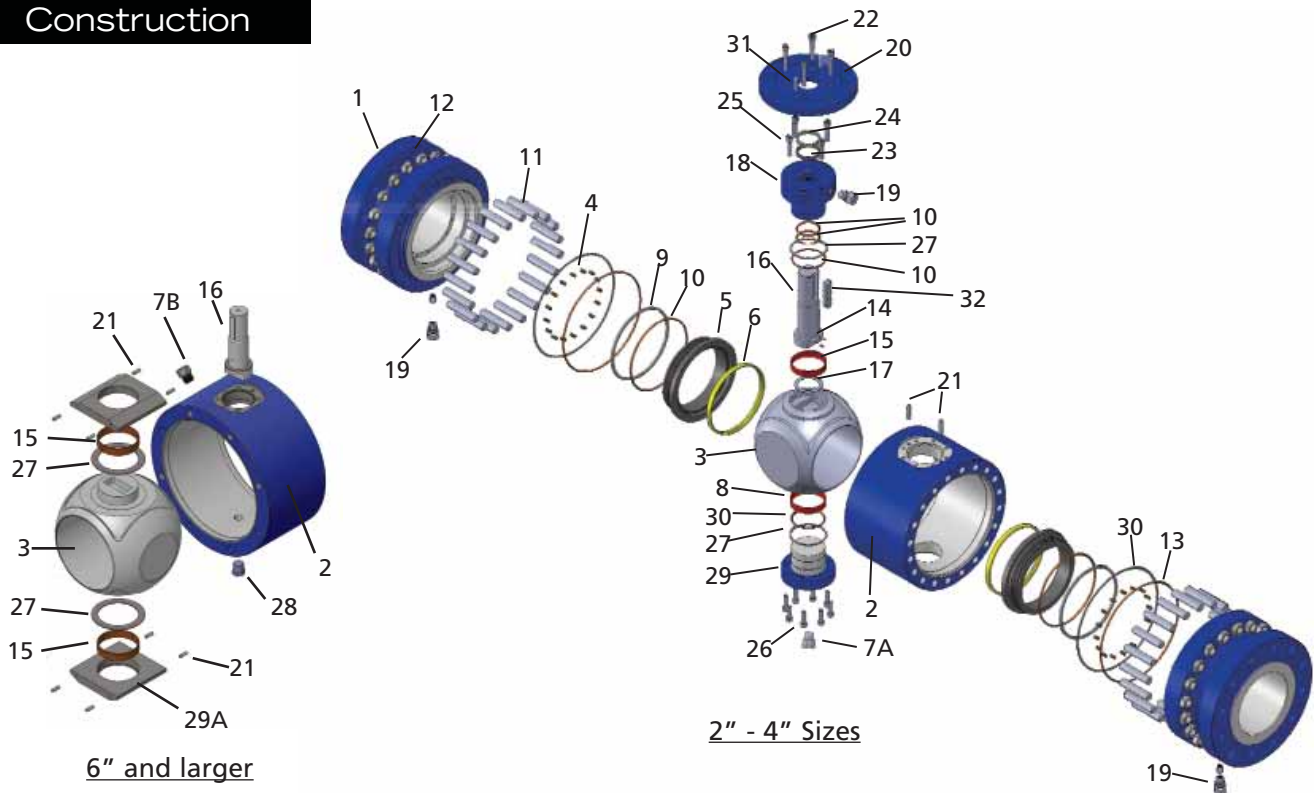

Figure 1. Flow Pattern Comparison

QuadroSphere® Ball Valves

Construction



Assy No.	Component	Standard QuadroSphere® Carbon Steel	Standard QuadroSphere® Stainless Steel	Assy No.	Component	Standard QuadroSphere® Carbon Steel	Standard QuadroSphere® Stainless Steel
1	Body Flange	ASTM A105 CS	ASTM A182 Type 316SS	17	Stem Bearing	RPTFE	RPTFE
2	Body	ASTM A105 CS	ASTM A182 Type 316SS	18	Stem Cover	ASTM A105 CS	ASTM A182 Type 316SS
3	QS Ball	ASTM A182 Type 316SS Hard Chrome Plating	ASTM A182 Type 316SS Hard Chrome Plating	19	Injection Fitting	ASTM A105 CS	ASTM A276 Type 316SS
4	Spring	Inconel X-750	Inconel X-750	20	Adaptor/Packing Retainer	ASTM A105 CS	ASTM A182 Type 316SS
5	Seat Ring	ASTM A182 Type 316SS	ASTM A182 Type 316SS	21	Pin	Carbon Steel	ASTM A276 Type 316SS
6	Seat Insert	RPTFE (150-300) PEEK (600-2500)	RPTFE (150-300) PEEK (600-2500)	22	Screw	ASTM A193-B7M	ASTM A193-B8M
7A	Vent Valve	AISI 316SS	AISI 316SS	23	Packing	Flex Graphite	Flex Graphite
7B	Relief Valve	AISI 316SS	AISI 316SS	24	Gland	ASTM A182 Type 316SS	ASTM A182 Type 316SS
8	Bearing	1045 + PTFE	1045 + PTFE	25	Screw	ASTM A193-B7M	ASTM A193-B8M
9	Seat Gasket	Graphite	Graphite	26	Screw	ASTM A193-B7M	ASTM A193-B8M
10	Seat & Stem O-rings	Viton®	Viton®	27	Gasket	316 + Graphite	316 + Graphite
11	Body Stud	ASTM A193-B7M	ASTM A193-B8M	28	Drain Plug	AISI 316SS	AISI 316SS
12	Body Nut	ASTM A194-2HM	ASTM A194-8M	29	Post Trunnion	ASTM A105 CS	ASTM A182 Type 316SS
13	Body Gasket	316SS + Graphite	316SS + Graphite	29A	Plate Trunnion	4130/4140 + ENP	A182 GR 316
14	Antistatic	ASTM A276 Type 316SS	ASTM A276 Type 316SS	30	O-ring	Viton®	Viton®
15	Bearing	1045 + PTFE	1045 + PTFE	31	Pin	Carbon Steel	ASTM A276 Type 316SS
16	Stem	ASTM A182 Type 316SS	ASTM A182 Type 316SS	32	Key Pin	1045 Carbon Steel	ASTM A479 Type 304SS / 420SS

Component Pressure & Temperature Limits

Component Designation Legend

Seat Insert Material: RPTFE, PEEK, Nylon, Devlon®, Carbon Fiber Filled PEEK (CFFP), Metal

O-Ring Material: Aflas®, HNBR, Chemraz®, Markez®, Kalrez®, Viton®, Viton® AED, FF200, Graphite

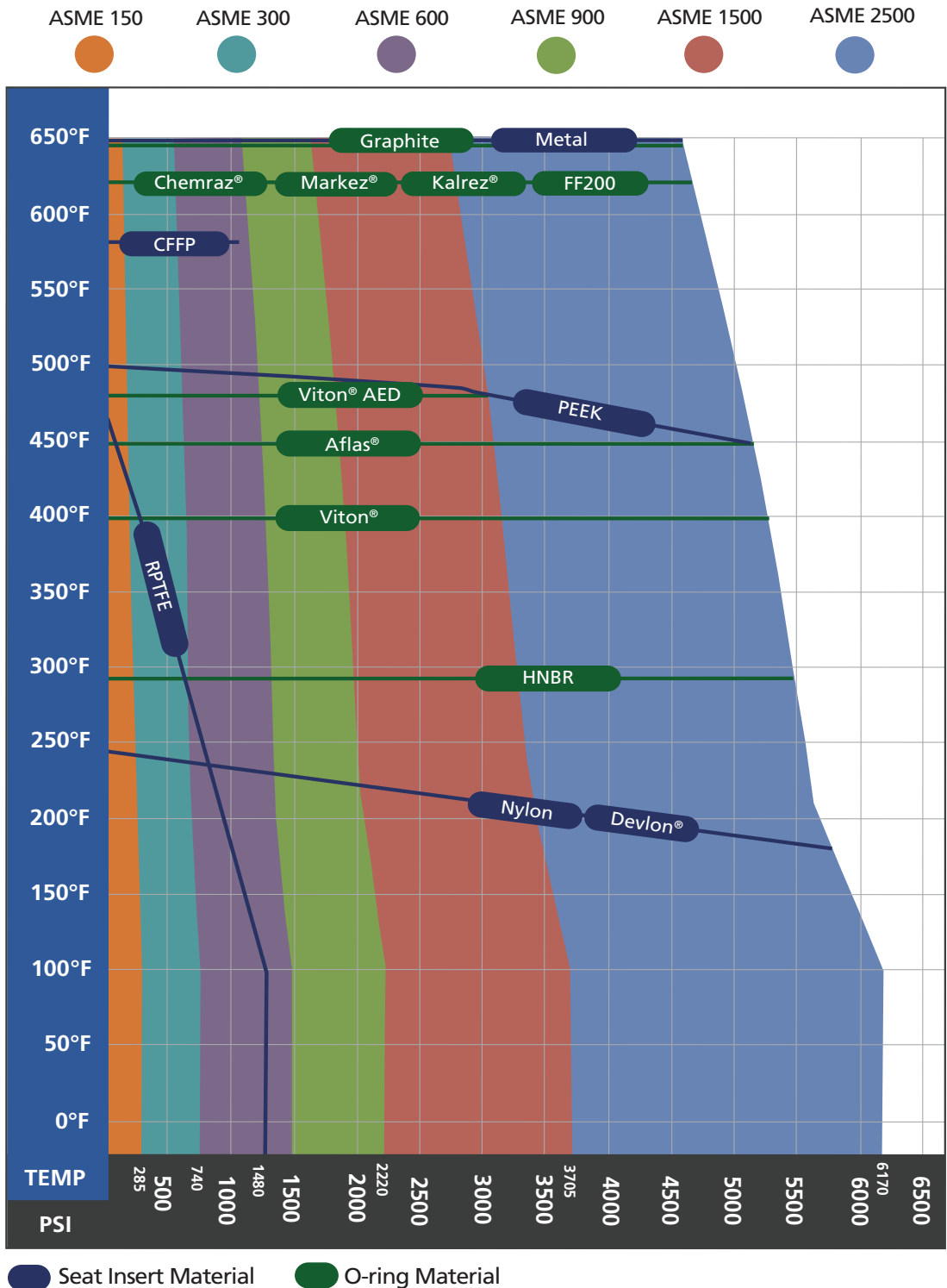

Figure 2 - Pressure and Temperature Limits

Design Features

Ball Valve Single Piston Effect Seating

Single Piston Effect Seating (API 6D DBB)

In the standard configuration, the ball valve seats are floating and are activated by springs and line pressure to seal tightly against the QuadroSphere® Ball. The seats have an O-ring seal on the outside diameter and a resilient seat insert at the center creating a piston effect area. Upstream and downstream line pressure act over this piston area to force the seals with the required thrust to seal tightly against the ball, Figure 3.

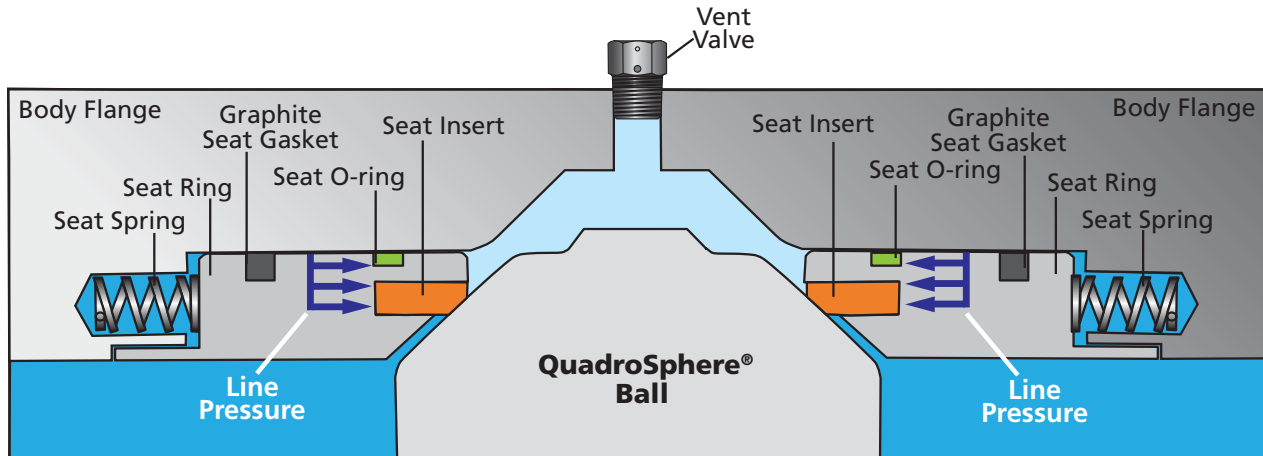

Figure 3 - Bi-directional Sealing

If pressure in the valve cavity between the seats exceeds the upstream or downstream pressure, the piston effect will work in the opposite direction and automatically relieve any overpressure, Figure 4. Additionally, the valve body is equipped with vent and drain connections to verify seat integrity with the valve in service. The single piston effect is defined in API 6D as Double-Block-and-Bleed (DBB) design. Since the cavity is automatically relieved, any leakage through the first seat will also be relieved by the second seat so DBB valves do not provide positive double isolation.

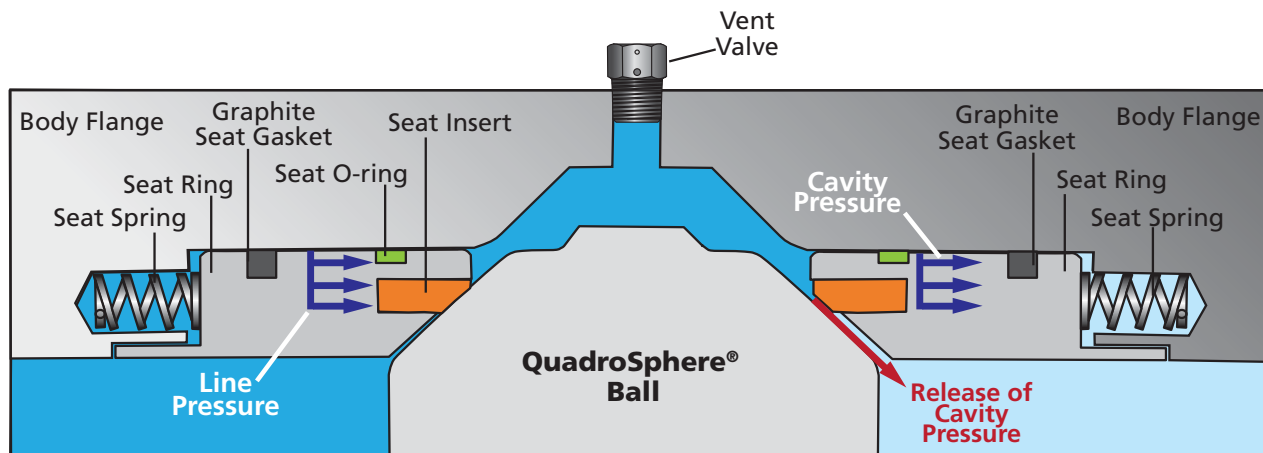

Figure 4 - Self-Relieving Seats

Ball Valve Double Piston Effect Seating

Double Piston Effect Seating (API 6D DIB)

In the optional configuration, the ball valve seats have an enlarged O-ring groove that allows the O-ring to be activated bi-directionally by either the line pressure or the cavity pressure. As with the single piston design, the line pressure acts over the piston area to force the seals with the required thrust to seal tightly against the QuadroSphere® Ball, Figure 5.

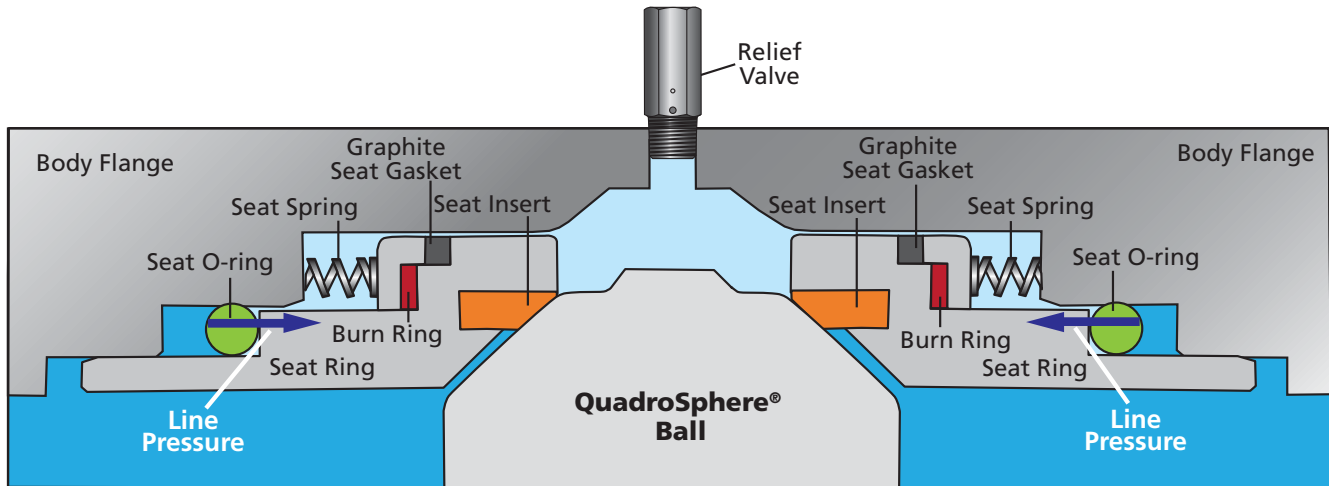

Figure 5 - Cavity Isolation

In addition, the cavity pressure is connected to the opposite O-ring seal and will also force the ball valve seat against the ball, Figure 6. Therefore, both valve seats will seal with line pressure from the same direction when needed, providing positive double isolation. To avoid overpressure in the ball valve cavity due to thermal expansion, an automatic cavity pressure relief device is provided. The double piston effect is defined in API 6D as Double-Isolation-and-Bleed (DIB) and can be provided in one or both directions. Since both the upstream and downstream seats are activated by line and cavity pressure, DIB valves provide reliable double isolation.

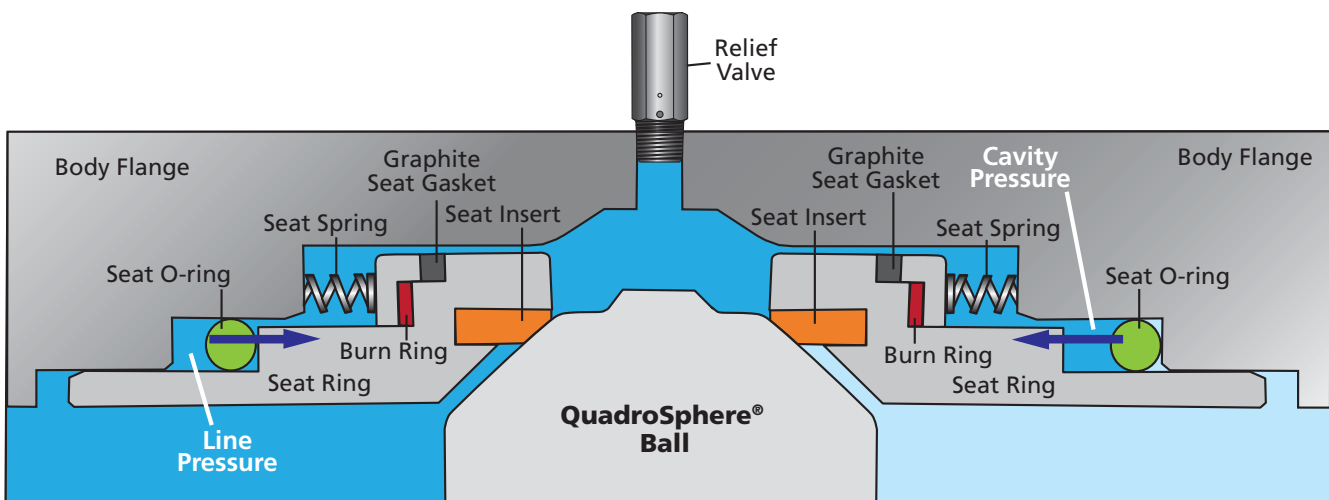

Figure 6 - Double Isolation of Cavity

Design Features

Soft Seated Valves

QuadroSphere® Ball Valves are equipped with two independent floating seat rings. These seat rings have resilient seat inserts installed into the seat ring to provide primary soft seating in addition to the secondary metal to metal seating between the ball and the seat ring. The sealing between the seat ring and the valve body flange is achieved by means of the seat O-ring and graphite seat gasket, Figure 7.

Bi-Directional Seating

The standard QuadroSphere® Ball Valve has bi-directional seating, which means the valve will seal with the line pressure coming from the upstream side of the valve or from the downstream side of the valve. Also the valve can be installed in the pipeline without having to ensure proper seating orientation of the valve, unlike some other ball valves.

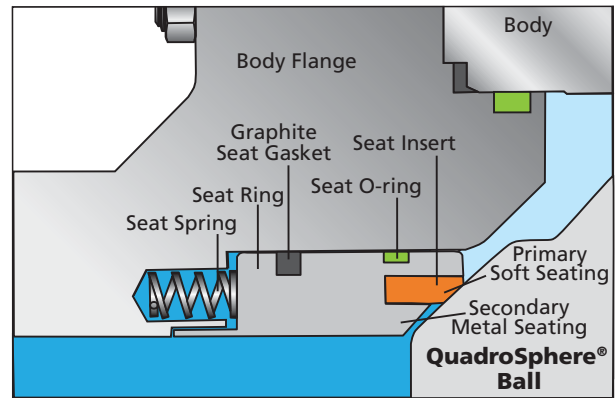

Figure 7 - Soft Seated Valves

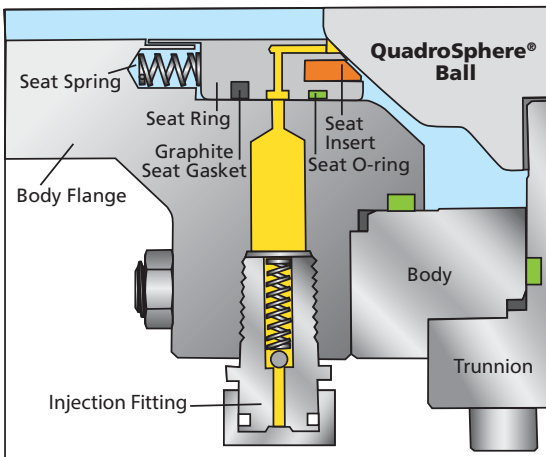

Figure 8 - Emergency Sealant Injection

Emergency Sealant Injection

The design of QuadroSphere® Ball Valves does not require the use of a sealant injection for standard operation. An emergency sealant injection system for stem seals and seat rings is a standard feature on all 6 NPS and larger QuadroSphere® Ball Valves with the single piston design. In the event of damage to the seat insert or stem seals, sealant can be injected to temporarily seal the valve until repairs can be made, Figure 8. (For certain chemical applications, the sealant injection fittings may not be suitable. Consult factory with application for compatibility.)

Fire-Safe - Single Piston

The Fire-Safe QuadroSphere® Ball Valve is designed, tested and certified to API 607. Figure 9 shows the single piston standard seat design. During a fire the seat insert and O-ring are destroyed and the seat gasket, made of graphite material, will remain to seal off the media along with the secondary metal seat on the seat ring.

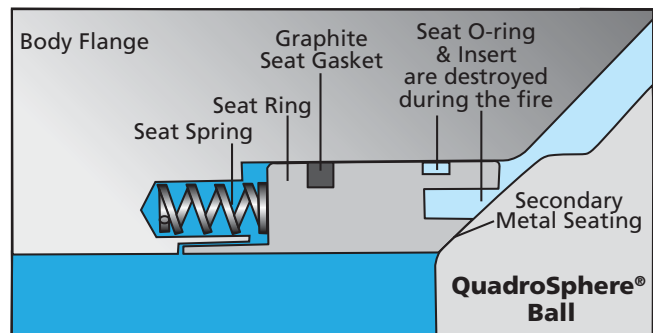

Figure 9 - Fire-Safe Single Piston

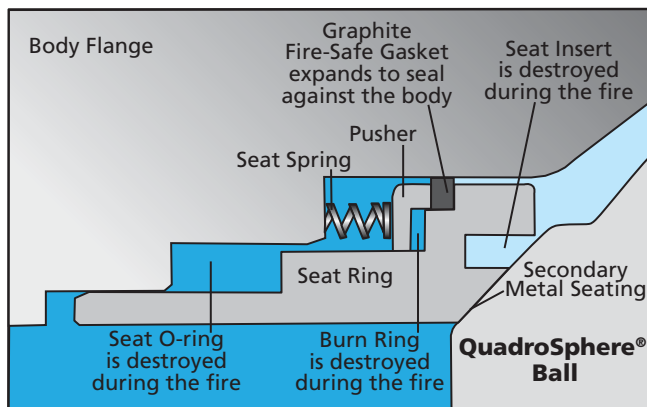

Figure 10 - Fire Safe - Double Piston

Fire-Safe - Double Piston

Figure 10 shows the seat configuration before the fire, where there is a gap between the gasket and the body. Figure 10 shows the seat configuration after a fire, where the burn ring has melted away and permits the seat graphite pusher to compress the gasket against the body to create a seal. The Double Piston Fire-Safe design does not permit the use of the emergency sealant injection.

Industry	Applications
Oil & Gas Pipelines	Tank Farms, Meter Stations, Pumps Isolation, Offshore Platforms, Fracking Water Treatment Systems, Heat Exchanger Water, Compressor Stations, Pig Launchers & Receivers, SAGD
Salt Domes	Salt Dome Brine & Gas, Salt Dome Wells & Storage
Refining	Drum Feed, Drum Blow Down, Vapor Lines, Quench Water, Bypass, Drain, Low Pressure Steam, Hot Oil, Isolation
Geothermal	Concentrated Brine & Natural Gas, Well Christmas Tree Master & Crown Valve, Vent Lines
Power	Fly Ash Water/Slurry, River Water, Pump Isolation, Crude Oil, Low Steam Pressure
Chemical	PVC Reactors Outlet/Diverter Service, PVC Waste Pump Isolation, PVC Slurry, Lock Hopper Isolation, Reactor Feed & Isolation
Pulp & Paper	White, Green and Black Liquor
Petrochemical	LNG Vaporization
Mining/Steel	Tailings, Dirty Mine Water, Gases & Liquids
Wastewater	Sludge, Treatment Chemicals, Waste Oil, Leachate

Installations



Master Valve Geothermal Brine



Salt Cavern Brine Well



Crude Oil Pumping Station Pig Launcher/Receiver



Salt Dome Brine & Gas Pumping Station

Ring Master®

The Ring Master® Seating System shown in Figure 12 provides excellent shut-off and ease of operation in applications when sand, scale, powders and other solids are present in the media. The Ring Master® is composed of a seat retaining ring and a dynamic, pressure-energized seat insert composed of various materials such as RTFE, PEEK, or Metal. The seat is energized with a clean independent external pressure source. Because the pressure behind the dynamic seat is higher than the line pressure, there will be no ingress of media from the pipeline into the seat cavity, ensuring the free axial movement of the seat against the ball under all process conditions.



Figure 11 is a QuadroSphere® Ball Valve equipped with a Ring Master® Seating System, which provides bi-directional shut-off and positive double isolation and bleed service (DIB). It will handle flow from either side and does not have to be installed in a preferred direction. The two seats operate independently of each other and therefore provide reliable double isolation. To avoid overpressure in the ball valve cavity due to thermal expansion, an automatic cavity pressure relief device is provided.

The ball valve seat inserts are activated by wave springs and external pressure to seal tightly against the ball. The external pressure is applied to the seat by a process compatible fluid or gas such as grease, air, nitrogen, or other clean fluid. The body is configured with the appropriate connections, piping, and valves to facilitate the application of the external pressure. The pressure is provided and maintained by either a pre-charged accumulator, an external regulated pressure source, or other clean fluid.

Figure 11 - QuadroSphere® with Ring Master® Seating System

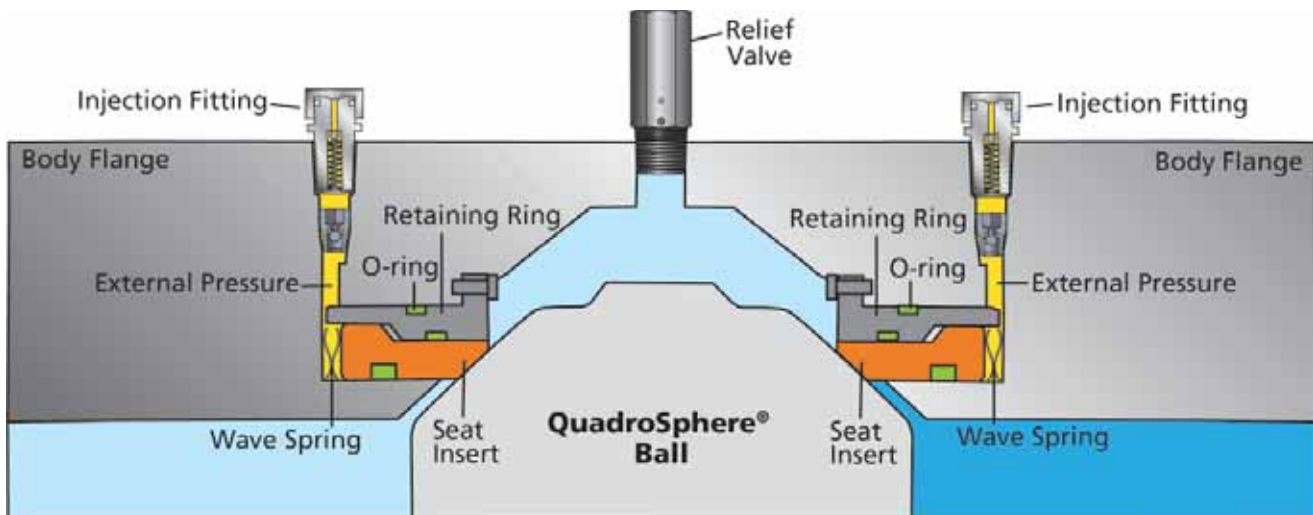

Figure 12 - Ring Master® Seating System

External Sealing Options

Spring Force

The Ring Master® floating seats are activated by wave springs and external pressure to seal tight against the QuadroSphere® Ball. For higher pressures, the external injection fitting can be used to inject sealant into the spring cavity behind the seat insert and provide additional seating force when needed or act as an emergency backup when needed. An internal check valve is provided to allow the removal of the injection fitting so that an external pressure source can also be used.

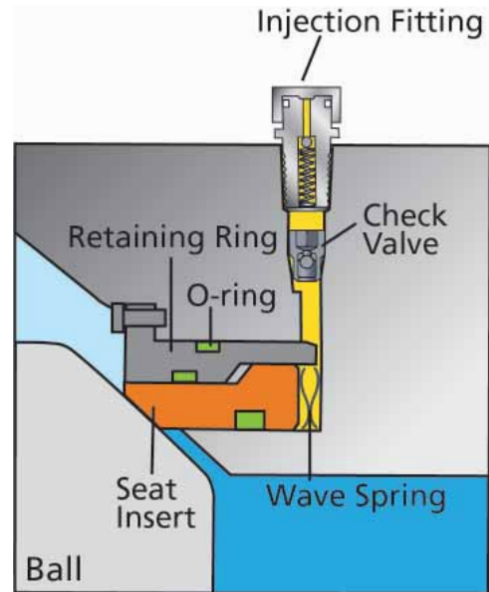
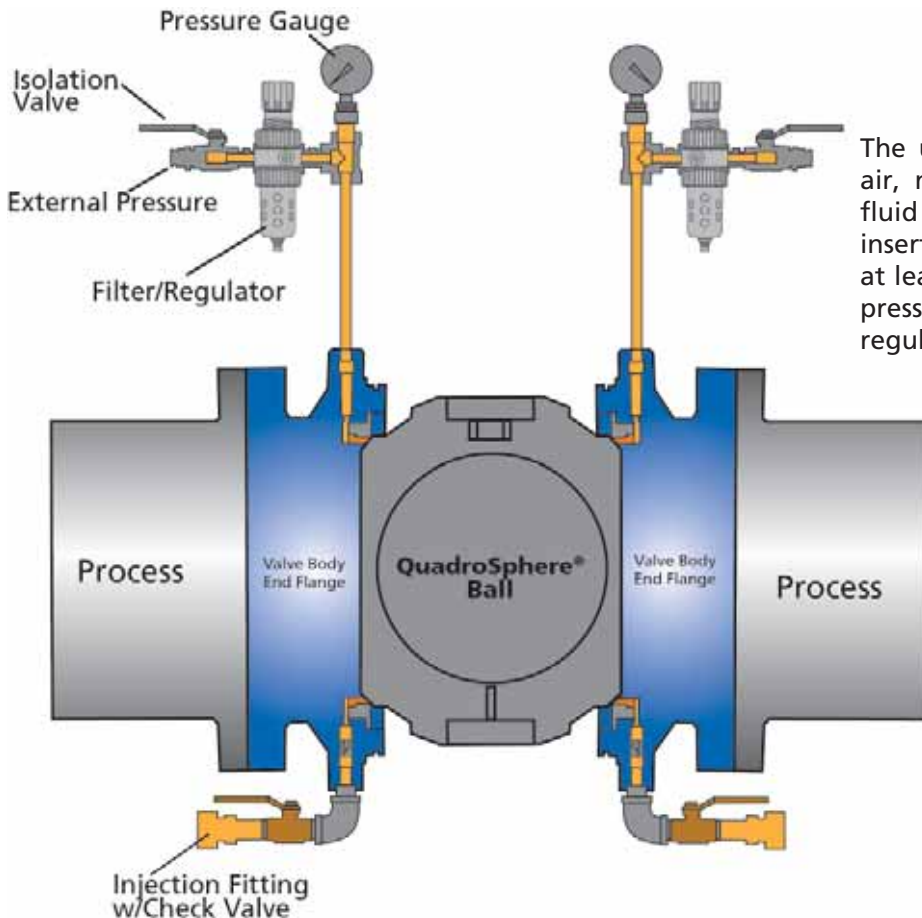

Figure 13 - Spring Force Sealing Option

External Pressure



The use of external pressure such as air, nitrogen, grease, or other clean fluid can be used to power the seat insert. The external pressure should be at least equal to the expected process pressure. The fluid can be filtered and regulated as shown in Figure 14.

Figure 14 - External Pressure Sealing Option

Ring Master®

External Sealing Options

Accumulator & Pressurized Fluid

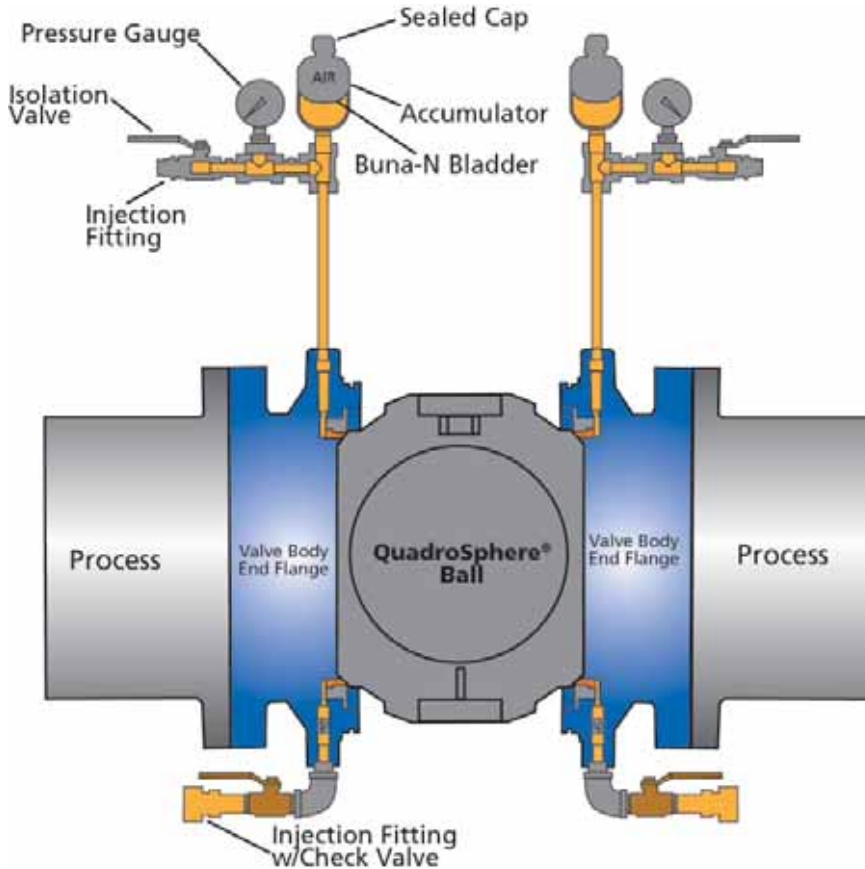

When the process fluid contains solids, an independent sealant or other fluid compatible with the process media is used to pressurize the seat insert to force it against the ball and provide tight shutoff, Figure 15. The pressurized fluid is injected in the bottom port until the seat cavity is filled and pressurized fluid is expelled out of the isolation valve. The isolation valve is closed and the injection is continued until the pre-charged accumulator is filled to the desired sealing pressure, which should be above the maximum system line pressure. The accumulator will maintain that pressure for extended periods independent of changes in the process conditions.

Figure 15 - Accumulator & Pressurized Fluid Option

Installations



QuadroSphere® with Ring Master® Seating System for Geothermal Brine Clarifier Tank Valve



QuadroSphere® with Injection Fitting to be used in Lock Hopper Service for a Pyrolysis Reactor

QuadroSphere® and Ring Master®

Series	ASME Rating	Size Range NPS (DN)	CWP* (psig)
4700A1	150	2 - 24 (50-600)	285
4700A3	300	2 - 24 (50-600)	740
4700A6	600	2 - 24 (50-600)	1480
4700A9	900	2 - 16 (50-400)	2220
4700AA	1500	2 - 16 (50-400)	3705
4700AB	2500	2 - 6 (50-150)	6170

*Based on Carbon Steel
Consult factory for additional sizes and pressure class availability.

Industry Compliance

Basic Design	ASME B16.34/API 6D
Face-to-Face Dimension	API 6D
Flanged End Dimension	ASME B16.5
Inspected & Tested to	API 6D
Firesafe Certification	API 607
Quality Certification	ISO 9001
Fugitive Emission	ISO-15848-2
Actuator Mounting	ISO 5211

Product Options:

Extended bonnet, Double piston effect seats w/ relief valve, Special coatings, NACE
Low pressure seat tests can be performed per customer requirements.

End Connections:

Standard: Flanged

Optional: Butt Weld or Ring Tongue Joint (RTJ)

ASME Ratings

Pressure/Temperature Ratings (PSIG)

Material		Class 150	Class 300	Class 600	Class 900	Class 1500	Class 2500
A105 & LF2	100°F	285	740	1480	2220	3705	6170
	200°F	260	680	1360	2035	3395	5655
	300°F	230	655	1310	1965	3270	5450
	400°F	200	635	1265	1900	3170	5280
	500°F	170	605	1205	1810	3015	5025
	600°F	140	570	1135	1705	2840	4730
F316	100°F	275	720	1440	2160	3600	6000
	200°F	235	620	1240	1860	3095	5160
	300°F	215	560	1120	1680	2795	4660
	400°F	195	515	1025	1540	2570	4280
	500°F	170	480	955	1435	2390	3980
	600°F	140	450	900	1355	2255	3760

Consult factory for higher temperatures.

Available Materials

Component	Material
Body	LF2, LCB, Duplex Stainless Steel
Seat Insert	RPTFE, PEEK, Nylon, Devlon®, Carbon Fiber Filled PEEK (CFFP), Metal
Seat Ring	Stainless Steel, CS/ENP, LF2/ENP, SS410
Seal	Aflas®, Chemraz®, Markez®, Viton® AED, Viton, HNBR, Kalrez®, FF200, Graphite
Stem	17-4PH, Duplex Stainless Steel, Stainless Steel, CS/Plated
Ball Surface	Stellite, Electroless Nickel Plating, Tungsten Carbide Coating
Metal Seat	Seat Ring Faced with Stellite, Electroless Nickel Plating, Tungsten Carbide Coating over various seat ring materials

Note: Consult Factory for other materials.

Material	Temperature	
	Low	High
Aflas®	-5°F	450°F
CFFP	20°F	580°F
Chemraz®	-4°F	615°F
Devlon®	-40°F	250°F
FF200	5°F	615°F
HNBR	-40°F	290°F
Kalrez®	0°F	615°F
Markez®	5°F	615°F
Nylon	-40°F	250°F
PEEK	20°F	500°F
RPTFE	-50°F	450°F
Viton	-15°F	400°F
Viton® AED	-5°F	475°F

Flow Coefficients (Cv)

Size (NPS)	ASME 150	ASME 300	ASME 600	ASME 900	ASME 1500	ASME 2500	Size (DN)
2	450	430	370	330	320	300	50
3	1360	1100	1020	920	830	520	80
4	2000	2000	1850	1760	1660	1200	100
6	5500	5500	4400	4300	4167	2900	150
8	10000	10000	8450	8400	8013		200
10	17000	17000	14250	14160	13309		250
12	24000	24000	24000	21320	17073		300
14	32600	28000	28000	26600	24500		350
16	44700	36000	36000	36000	33215		400
18	57825	56225	57410				450
20	74775	71800	65463				500
24	113284	109414	98963			600	

Trunnion Design • ASME Class 150

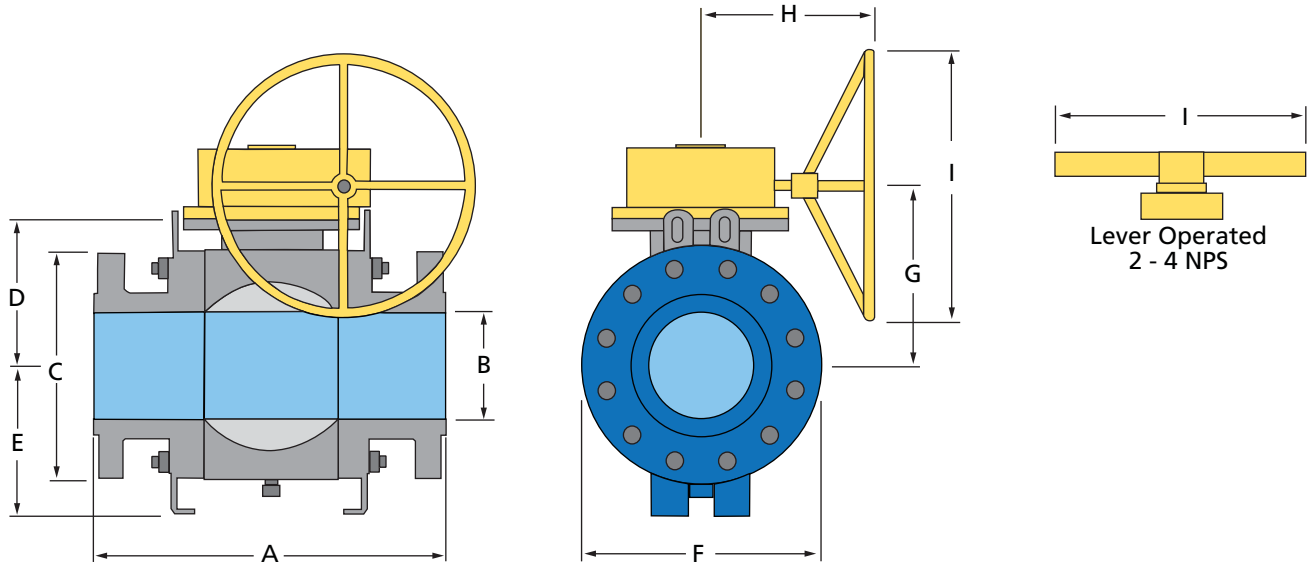

Class 150 - Dimensions in Inches (mm)

Size NPS (DN)	A	B	C	D	E	F	G	H	I	Weight LB (KG)
2 (50)	7.00 (178)	1.93 (49)	6.00 (152.4)	3.88 (98.43)	-	6.02 (153)	6.40 (163)	-	13.80 (350)	56 (25)
3 (80)	8.00 (203)	2.91 (74)	7.50 (191)	5.38 (136.3)	-	7.52 (191)	6.40 (163)	-	18.10 (460)	76 (35)
4 (100)	9.00 (229)	3.94 (100)	9.00 (228.6)	6.19 (157.2)	-	9.13 (232)	7.10 (180)	-	18.10 (460)	115 (52)
6 (150)	15.50 (394)	5.91 (150)	11.00 (279.4)	7.00 (177.8)	7.36 (187)	12.09 (307)	10.90 (277)	11.94 (303.2)	15.70 (400)	415 (189)
8 (200)	18.00 (457)	7.91 (201)	13.50 (342.9)	8.75 (222.3)	8.82 (224)	15.43 (392)	14.10 (358)	11.94 (303.2)	15.70 (400)	752 (342)
10 (250)	21.00 (533)	9.92 (252)	16.00 (406.4)	11.25 (285.8)	10.94 (278)	18.31 (465)	16.20 (412)	14.63 (371.5)	19.70 (600)	1020 (464)
12 (300)	24.00 (610)	11.93 (303)	19.00 (482.6)	12.63 (320.7)	12.05 (306)	21.38 (543)	18.20 (462)	14.63 (371.5)	23.60 (600)	1555 (707)
14 (350)	27.00 (686)	13.15 (334)	21.00 (533.4)	15.70 (400)	15.30 (388)	25.10 (638)	18.50 (470)	20.40 (518)	23.60 (600)	1600 (727)
16 (400)	30.00 (762)	15.16 (385)	23.50 (596.9)	16.70 (423)	17.70 (450)	28.00 (710)	19.40 (493)	18.70 (475)	27.60 (700)	2244 (1020)
18 (450)	34.00 (864)	17.17 (436)	25.00 (635)	19.10 (485)	19.50 (495)	31.90 (810)	22.30 (566)	22.60 (575)	27.60 (700)	2673 (1215)
20 (500)	36.00 (914)	19.17 (487)	27.50 (698.5)	21.10 (537)	21.40 (543)	34.10 (865)	24.30 (618)	22.60 (575)	27.60 (700)	3945 (1793)
24 (600)	42.00 (1067)	21.18 (539)	32.00 (813)	24.30 (616)	23.20 (590.5)	40.40 (1025)	27.80 (705)	23.30 (592)	31.50 (800)	6818 (3099)

- Notes:
1. Ball Diameter Dimensions (B) are per API 6D design convention for full port valves.
 2. Additional materials and design configurations available. Please contact factory.

Installation Dimensions

Trunnion Design • ASME Class 300

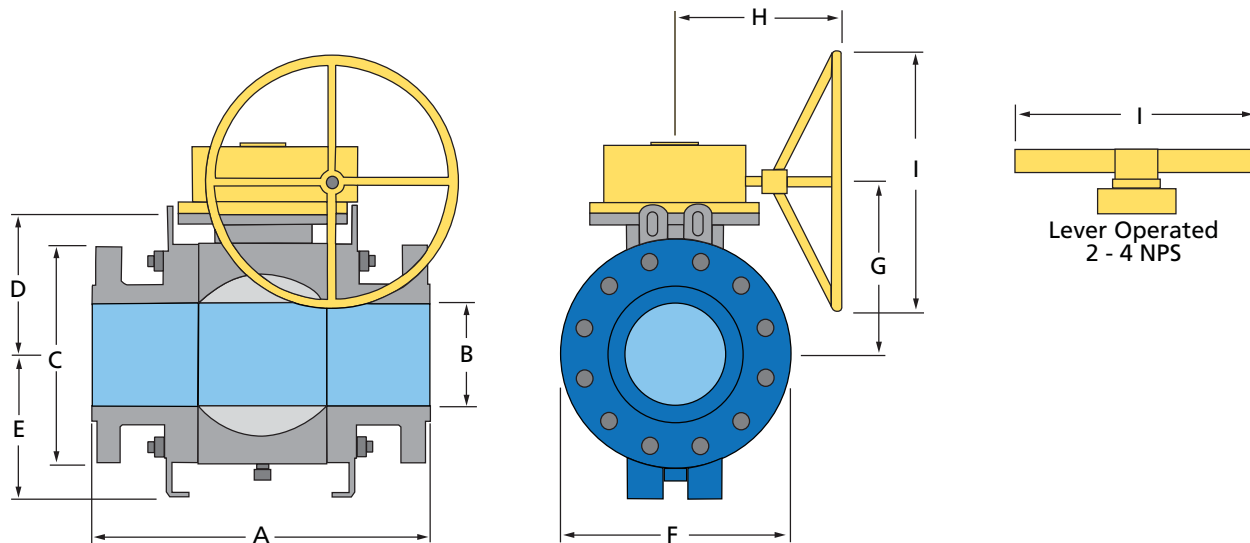

Class 300 - Dimensions in Inches (mm)

Size NPS (DN)	A	B	C	D	E	F	G	H	I	Weight LB (KG)
2 (50)	8.50 (216)	1.93 (49)	6.50 (165.1)	3.88 (98.4)	-	3.90 (100)	6.40 (162.56)	-	13.80 (350)	65 (30)
3 (80)	11.13 (283)	2.91 (74)	8.25 (209.6)	5.38 (136.3)	-	8.30 (210)	6.40 (162.56)	-	17.70 (450)	122 (55)
4 (100)	12.00 (305)	3.94 (100)	10.00 (254)	6.19 (157.2)	-	10.00 (254)	7.10 (180.34)	-	23.60 (600)	202 (92)
6 (150)	15.88 (403)	5.91 (150)	12.50 (317.5)	7.00 (177.8)	7.90 (200)	12.50 (317.5)	10.90 (277)	11.94 (303.2)	15.70 (400)	447 (203)
8 (200)	19.75 (502)	7.91 (201)	15.00 (381)	8.75 (222.3)	9.10 (230)	15.20 (385)	14.10 (358)	11.94 (303.2)	15.70 (400)	785 (357)
10 (250)	22.36 (568)	9.92 (252)	17.50 (444.5)	11.25 (285.8)	11.60 (295)	18.50 (470)	16.20 (412)	14.63 (371.5)	23.60 (600)	1115 (507)
12 (300)	25.50 (648)	11.93 (303)	20.50 (520.7)	12.63 (320.7)	13.00 (330)	21.30 (540)	18.20 (462)	14.63 (371.5)	27.60 (700)	1622 (737)
14 (350)	30.00 (762)	13.15 (334)	23.00 (584.2)	15.70 (400)	15.30 (388)	25.10 (638)	18.50 (470)	20.40 (518)	23.60 (600)	1890 (859)
16 (400)	33.00 (838)	15.16 (385)	25.50 (647.7)	16.70 (423)	16.70 (423)	28.00 (710)	19.40 (493)	22.60 (575)	27.60 (700)	2650 (1205)
18 (450)	36.00 (914)	17.17 (436)	28.00 (711)	19.20 (488)	19.60 (498)	32.30 (820)	22.40 (569)	22.60 (575)	27.60 (700)	3502 (1592)
20 (500)	39.00 (991)	19.17 (487)	30.50 (774.7)	21.20 (538)	21.60 (549)	34.40 (874)	24.70 (627)	23.30 (592)	31.50 (800)	4829 (2195)
24 (600)	45.00 (1143)	21.18 (589)	36.00 (914)	24.60 (624)	23.40 (594)	40.90 (1040)	29.30 (744)	27.30 (693)	35.40 (900)	7612 (3460)

- Notes:
1. Ball Diameter Dimensions (B) are per API 6D design convention for full port valves.
 2. Additional materials and design configurations available. Please contact factory.

Installation Dimensions

Trunnion Design • ASME Class 600

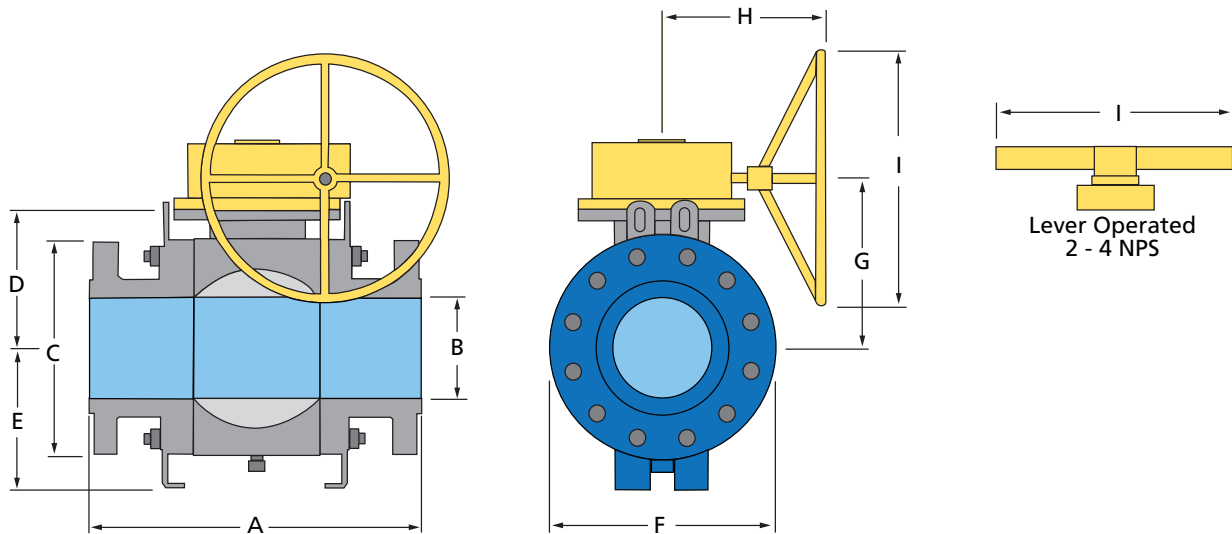

Class 600 - Dimensions in Inches (mm)										
Size NPS (DN)	A	B	C	D	E	F	G	H	I	Weight LB (KG)
2 (50)	11.50 (292)	1.93 (49)	6.50 (165.1)	6.10 (155)	-	6.50 (165)	6.40 (162.56)	-	21.70 (550)	99 (45)
3 (80)	14.00 (356)	2.91 (74)	8.25 (209.55)	6.70 (170)	-	9.00 (229)	6.40 (162.56)	-	27.55 (700)	176 (80)
4 (100)	17.00 (432)	3.94 (100)	10.75 (273.05)	8.00 (201)	-	10.40 (264)	7.10 (180.34)	-	33.50 (850)	308 (140)
6 (150)	22.00 (559)	5.91 (150)	14.00 (356)	9.10 (230)	9.20 (234.5)	12.60 (319)	11.50 (292)	11.94 (303.2)	15.70 (400)	557 (253)
8 (200)	26.00 (660)	7.91 (201)	16.50 (419.1)	11.40 (290.5)	12.40 (316)	17.00 (432)	14.30 (363)	11.94 (303.2)	19.70 (500)	1067 (485)
10 (250)	31.00 (787)	9.92 (252)	20.00 (508)	13.00 (329)	15.70 (399)	20.40 (518)	16.50 (418.5)	14.63 (371.5)	23.6 (600)	1668 (758)
12 (300)	33.00 (838)	11.93 (303)	22.00 (558.8)	15.90 (404.7)	17.80 (451)	24.50 (622)	18.20 (463)	14.63 (371.5)	27.6 (609.6)	2347 (1067)
14 (350)	35.00 (889)	13.15 (334)	23.75 (603.25)	15.70 (400)	15.30 (388.5)	25.10 (638)	18.50 (470)	20.40 (518)	23.60 (600)	2383 (1083)
16 (400)	39.00 (991)	15.16 (385)	27.00 (686)	17.40 (443)	17.60 (445.8)	28.90 (735)	19.40 (493)	22.60 (575)	27.60 (700)	3355 (1525)
18 (450)	43.00 (1092)	17.17 (436)	29.30 (743)	19.60 (498)	20.10 (510.5)	33.10 (840)	22.40 (569)	22.60 (575)	27.60 (700)	4609 (2095)
20 (500)	47.00 (1194)	19.17 (487)	32.00 (812.8)	22.20 (565)	21.30 (542)	36.20 (920)	24.70 (627)	23.30 (592)	31.50 (800)	5804 (2638)
24 (600)	55.00 (1397)	21.18 (589)	37.00 (940)	24.60 (624.5)	23.50 (596)	41.10 (1045)	29.30 (744)	27.30 (693)	35.40 (900)	10419 (4736)

- Notes:
1. Ball Diameter Dimensions (B) are per API 6D design convention for full port valves.
 2. Additional materials and design configurations available. Please contact factory.

Model Number Breakdown

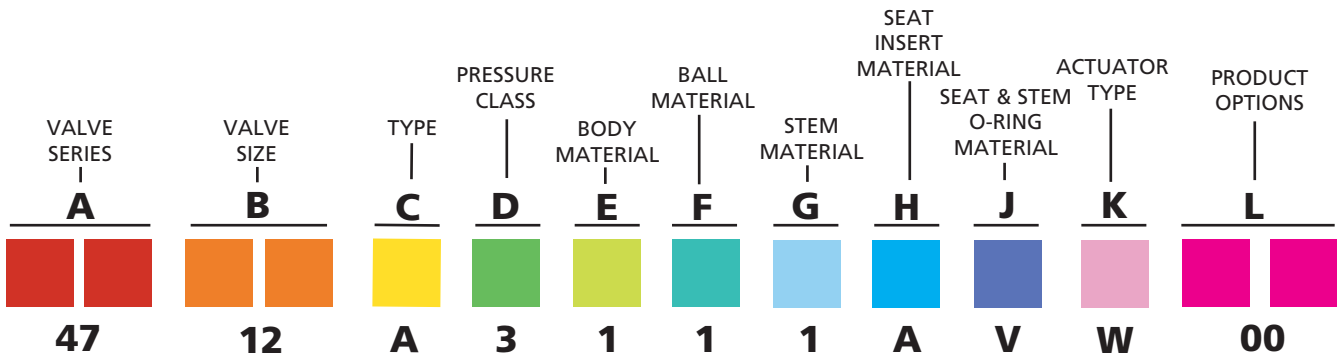

Example: 12 NPS Flanged, Trunnion, 3 Piece, Full Bore Ball Valve, Class 300, Carbon Steel A105 body, T316 stainless steel ball/HC, T316 Stainless Steel Stem, RPTFE Seat Insert, Viton® O-Ring, with a Worm Gear actuator.

A VALVE SERIES	F BALL MATERIAL cont'd
4700 - QuadroSphere® Ball Valve	8 - Stainless Steel 410/HC C - SS316L/HC 9 - T316 Stainless Steel/TCC D - SS316/Stellite #6 A - Stainless Steel 410/TCC E - LF2/TCC B - SS316L/TCC F - A105/TCC
B SIZE	G STEM MATERIAL
Sizes shown in NPS (DN) 2 (50) 8 (200) 16 (400) 3 (80) 10 (250) 18 (450) 4 (100) 12 (300) 20 (500) 6 (150) 14 (350) 24 (600)	1 - T316 SS 5 - Monel, K500 9 - LF2/ENP 2 - T410 SS 6 - Inconel, 625 A - SS316L 3 - T420 SS 7 - F51 SS 4 - 17-4 PH 8 - A105/ENP
C TYPE	H SEAT INSERT MATERIAL
A - RF Flanged, Trunnion, 3 Piece, Full Port B - Butt Weld, Trunnion, 3 Piece, Full Port C - RTJ Flanged, Trunnion, 3 Piece, Full Port D - RF Flanged, Trunnion, 3 Piece, Reduced Port E - RTJ Flanged, Trunnion, 3 Piece, Reduced Port S - Socket Weld, Trunnion, 3 Piece, Full Port T - Threaded, Trunnion, 3 Piece, Full Port	A - RPTFE F - Metal Seat/Stellite #6 B - Devlon® G - Metal Seat/TCC C - PEEK H - PCTFE/KEL-F D - Delrin J - 30% Carbon Fiber Filled PEEK E - Nylon K - TFM 1600 L - Metal Seat/Stellite #21
D ASME PRESSURE CLASS	J SEAT & STEM O-RING MATERIAL
1 - 150 9 - 900 3 - 300 A - 1500 6 - 600 B - 2500	V - Viton® B - Buna-N A - Aflas® D - Viton® AED M - Markez® H - HNBR E - EPDM HT 550°F F - FF200 K - Kalrez® J - E0962-90 EPDM G - Graphite L - FF400 C - Chemraz® N - Parker FF580
E BODY MATERIAL	K ACTUATOR TYPE
1 - Carbon Steel, A105 6 - T316L Stainless Steel, F316L 2 - Carbon Steel, LF2 3 - T316 Stainless Steel, F316 4 - Carbon Steel, LCB 5 - T316L Stainless Steel	B - Bare Stem M - Motor Actuator H - Hydraulic Actuator P - Pneumatic Actuator L - Lever W - Worm Gear
F BALL MATERIAL	L PRODUCT OPTIONS
1 - T316 Stainless Steel, F316/ Hard Chrome Plated (HC) 2 - Carbon Steel, A105 / HC 3 - Carbon Steel, LF2 / HC 4 - Carbon Steel, LCB / HC 5 - Stainless Steel, F51 / HC 6 - Carbon Steel, A105/ENP 7 - Carbon Steel, LF2/ENP	00 - Standard Construction XX - Factory Designation for options, i.e.: Special Coatings Double Piston Effect Seats Ring Master® Seating System Special Testing

SCOPE

1.1 This specification covers the design, manufacture, and testing of QuadroSphere® Trunnion Mounted Full Port Ball Valves furnished in sizes NPS 2 to 24, in ASME Pressure Classes 150 thru 2500.

SPECIFIC DESIGN CONSIDERATIONS

- 2.1 Valve to incorporate QuadroSphere® high integrity ball element to promote self-flushing feature and minimize seat wear.
- 2.2 Valve ball element to be relieved on top and bot-tom adjacent to trunnions to minimize seat and ball element engagement and promote self-flushing feature.
- 2.3 Valve ball element to be truncated on upstream and downstream ends to minimize seat and ball element engagement.
- 2.4 Ball engagement with seat shall be less than that of standard spherical ball during interim valve travel to promote sealing integrity.
- 2.5 Geometry of ball element shall allow (5) separate and distinct flow paths to maximize efficiency of flow during interim valve travel.
- 2.6 Valve seat and ball contact shall be minimized during interim travel such that minimal contact exists between ball and seat.
- 2.7 Valve seat and ball contact shall be reduced to four (4) independent line contact points on each seat during interim valve travel.

OTHER DESIGN CONSIDERATIONS

- 3.1 Valve to be trunnion mounted design to provide bi-directional sealing and to reduce running torque.
- 3.2 Valve ball to be 316 Stainless Steel with Hard Chrome applied as minimum standard.
- 3.3 Valve seats and stem to be 316 Stainless Steel construction as minimum standard.
- 3.4 Valve seats shall be a spring loaded/pressure energized design. They shall have an insert with a secondary metal seat back up.
- 3.5 The stem shall be anti-blowout design with anti-static devices.
- 3.6 NPS 4 valves and smaller to have drain, vent, and stem injection ports.
- 3.7 NPS 6 valves and larger to have drain, vent, stem, and two seat injection ports.
- 3.8 Valve shall incorporate double block and bleed sealing design (DBB).
- 3.9 Valve shall be capable of bi-directional flow.
- 3.10 Valve shall be capable of bi-directional shut-off.
- 3.11 Valve shall exhibit zero leakage per section 11 of API 6D.
- 3.12 Valve seat assemblies shall be field replaceable.
- 3.13 Valve body and ball shall be forged material.

STANDARDS AND APPROVALS

- 4.1 Valve to be manufactured per ASME B16.34 & API 6D.
- 4.2 Valve to carry API 6D Monogram.
- 4.3 Valve face-to-face dimensions to be per API 6D.
- 4.4 Valve Flanged end dimensions to be per ASME B16.5.
- 4.5 Valve Butt Weld end dimensions to be per ASME B31.4.

- 4.6 Valve to be available in anti-static and Fire-Safe design to API 607.
- 4.7 Valve top works shall have ISO 5211 compliant mounting pad.
- 4.8 Valve bolting material shall conform to be ASME B16.34.
- 4.9 Valve shall be permanently marked in accordance with API 6D. Valve shall not be marked on the flanges.
- 4.10 Manufacturer shall have a quality management system that is certified to ISO 9001 by an accredited, certifying body.
- 4.11 Valve shall meet Fugitive Emission Standard ISO-15848-2.

ACTUATION

- 5.1 Manual, electric or pneumatic actuation shall be provided as specified.
- 5.2 Lever handles are available for certain valve sizes and pressure classes. Consult factory.
- 5.3 Manual actuators shall be of the worm and gear design with externally adjustable stops. Actuators shall be lubricated and fully enclosed against the entry of water.
- 5.4 Pneumatic actuators shall be provided as specified.
- 5.5 Electric actuators shall be provided as specified.
- 5.6 Other types of actuation shall be provided as specified.

OPTIONS

- 6.1 Seating surface options are available for the ball and metal seats: Stellite, Electroless Nickel Plating, Tungsten Carbide Coating
- 6.2 Seat materials include: RPTFE, PEEK, Nylon, Devlon® Carbon Fiber Filled PEEK, Graphite and Metal.
- 6.3 Seal materials include: Aflas®, HNBR, Kalrez®, Chemraz®, Markez®, Viton®, Viton® AED and FF200.
- 6.4 NACE compliant trims are as specified for special services.
- 6.5 Double piston effect seating available on one or both ends (DIB).
- 6.6 Special coatings for the exterior and interior of the valve are available per application.
- 6.7 On NPS 6 and larger sizes for high solids service, a Ring Master® seating system shall be provided.

MANUFACTURE

- 7.1 Valve exteriors on carbon steel valves shall be coated with a rust inhibiting coating.
- 7.2 Valve shall be seat and shell tested in accordance with API 6D requirements.
- 7.3 Valve shall be cycle tested and stops set for manual, pneumatic or electric actuators.
- 7.4 QuadroSphere® Ball Valve shall be Val-Matic Model 4700, Trunnion Mounted Full Port Ball Valve as manufactured by Val-Matic® Valve & Mfg. Corporation, Elmhurst, IL. USA or approved equal.



VAL-MATIC®

Your Valve Experts™

Val-Matic Valve and Manufacturing Corp.
905 Riverside Drive, Elmhurst, IL 60126
Phone: (630) 941-7600 Fax: (630) 941-8042
www.valmatic.com
valves@valmatic.com

Copyright © 2020 Val-Matic Valve & Mfg. Corp.
ISO 9001:2015 Certified Company