

ITEM NO.	PART NUMBER	QTY.
1	.ASME 76 - 40BBL - TOP HEAD 2	1
2	INSIDE - BUBBLE JACKET - 48 IN. - BARREL - SUBASSEMBLY.SLDPRT	1
3	40BBL FRMNR - CONE - SUBASSEMBLY	1
4	INSIDE - BARREL - TOP	1
5	OUTSIDE - WRAP - BOTTOM	1
6	OUTSIDE - WRAP - TOP	1
7	76 D. 1.5 THK.INS. SUPPORT RING	1
8	40BBL FRMNR MAN-WAY ASSEM	1
9	4 IN.D. X 4 IN.L. DRY HOP INLET	1
10	2 IN.D. X 3 IN.L. VENT	1
11	2 IN.D. X 3.5 IN.L. RACKING PORT	2
12	76 - 40BBL - LEG - COMPONENT	4
13	40BBL UNI - 8IN. FT PAD	4
14	75 - 40BBL - CONE BOTTOM DISH - COMPONENT	1
15	FOOT RING - 2.25X4.375X.5	4
16	LEG NUT	4
17	1.5 IN.D X 4.5 IN. DRAIN	1
18	CIP INLET - 3X1.125	1
19	1x4 S40 NIPPLE 304	4
20	1.5x1 S40 - NIPPLE RING	2
21	1.D. X 4.5 - SAMPLE PORT	1
22	BEZEL 5.5 x 1 - FULL	4
23	BEZEL 5.5 x 2	2
24	BEZEL 5.5 x 1	2
25	76 - 40BBL - LEG BRACE	4
26	RACKING ARM TUBE ASSEMBLY	1
27	FRMNR - BRIGHT TANK - CIP - PLUMBING - ASSEMBLY	1

[JMB] STAINLESS	JOB NAME: 40BBL UNI SIZE VOL. AND SHAPE		SALES ORDER / CONTACT: JMB STAINLESS	
	TOLERANCE: +/- 1/16"	MATERIAL: 304 S.S.	MODEL NUMBER: 40BBL UNI	REVISION: A
	DRAWN BY: O. W. D.		DATE: Tuesday, January 23, 2018	

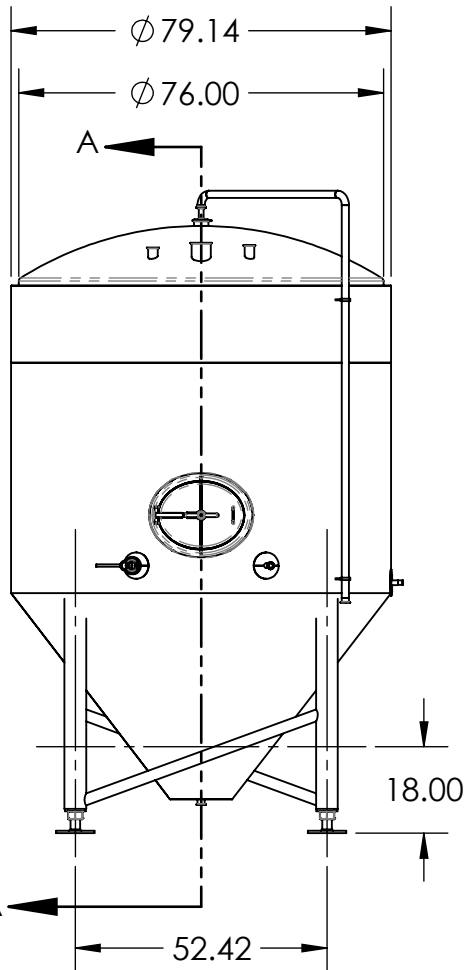

LEG

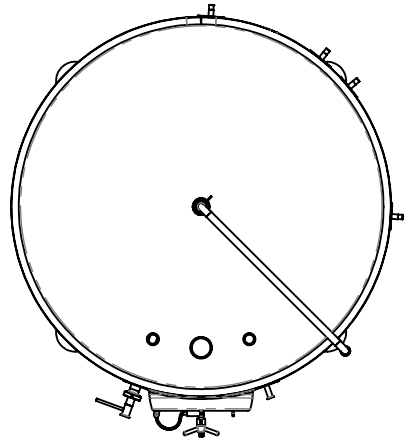
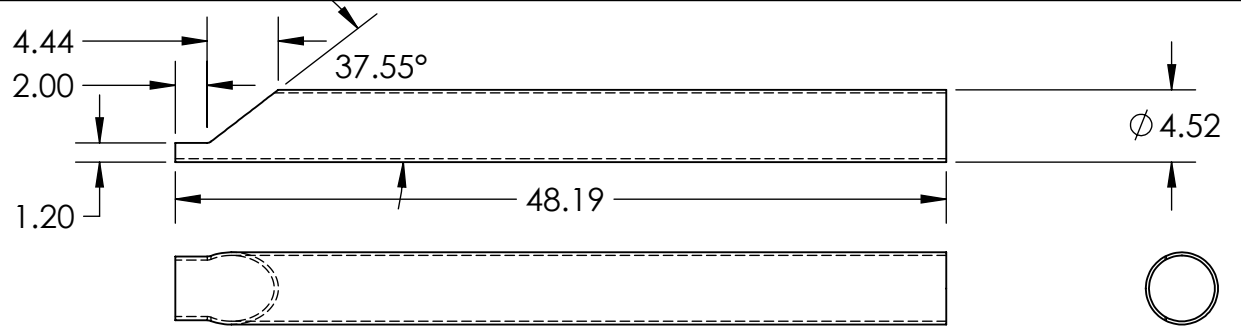

LEG BRACE

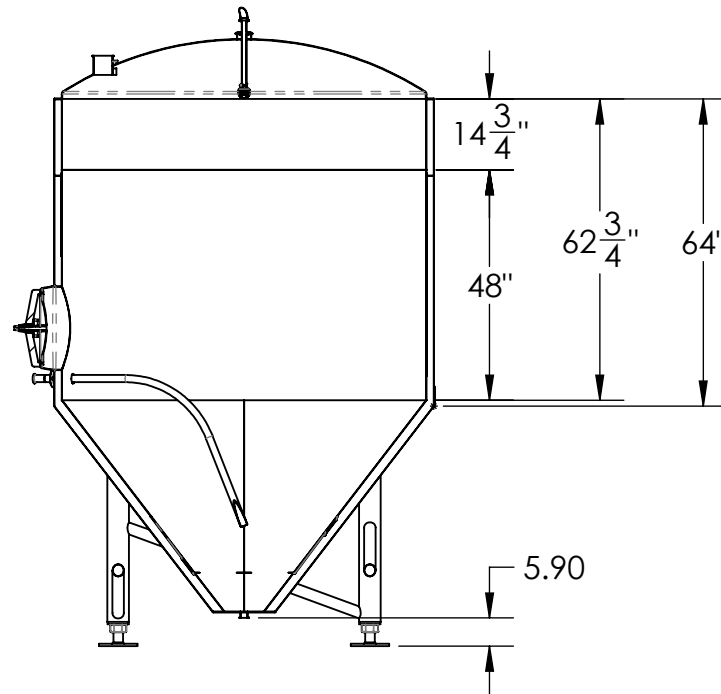
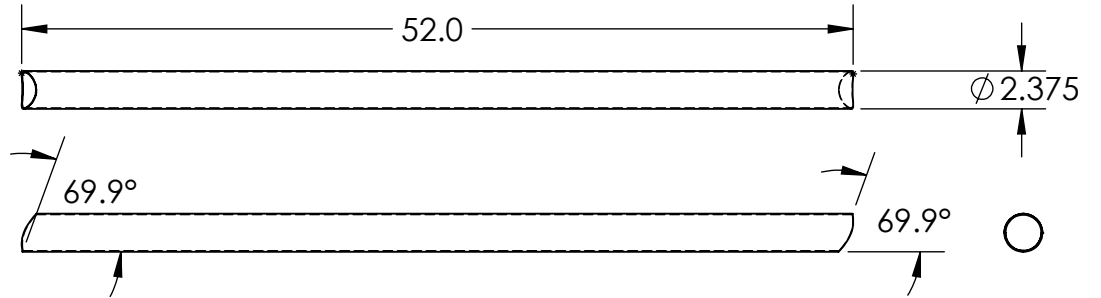

SECTION A-A
SCALE 1 : 40

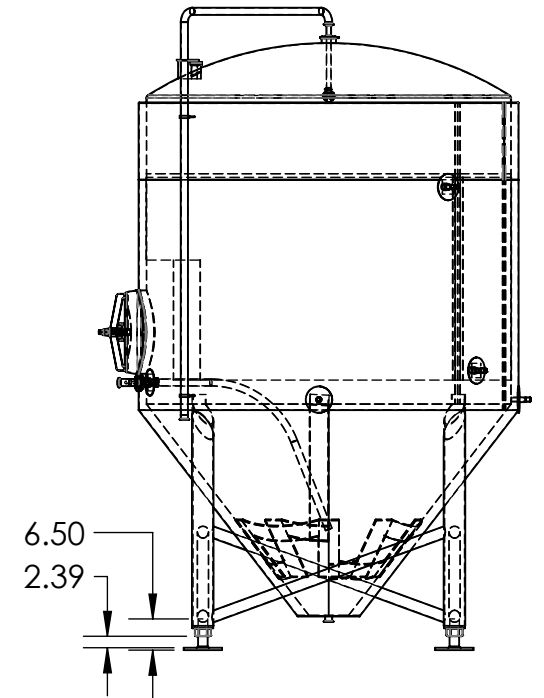

[JMB]
STAINLESS

JOB NAME:	40BBL UNI SIZE VOL. AND SHAPE	SALES ORDER / CONTACT:	JMB STAINLESS
TOLERANCE:	+/- 1/16"	MATERIAL:	304 S.S.
MODEL NUMBER:	40BBL UNI	REVISION:	A
DRAWN BY:	O. W. D.	DATE:	Tuesday, January 23, 2018

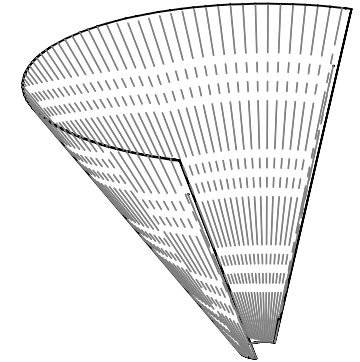
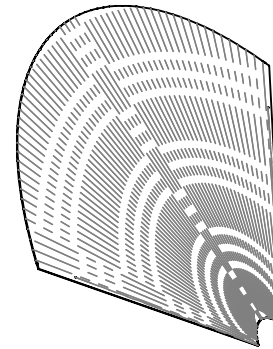
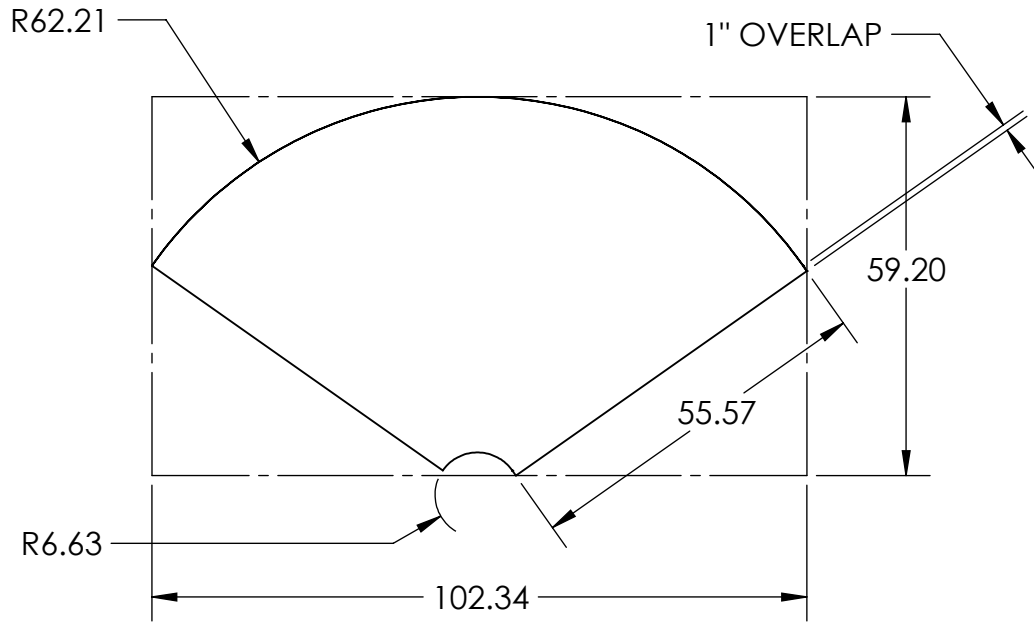

INSIDE 1/2 CONE

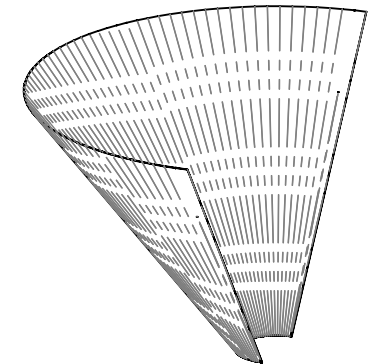
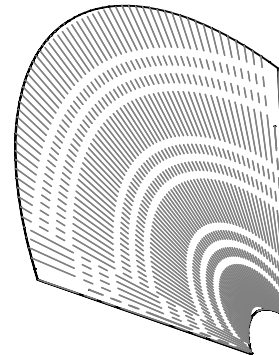
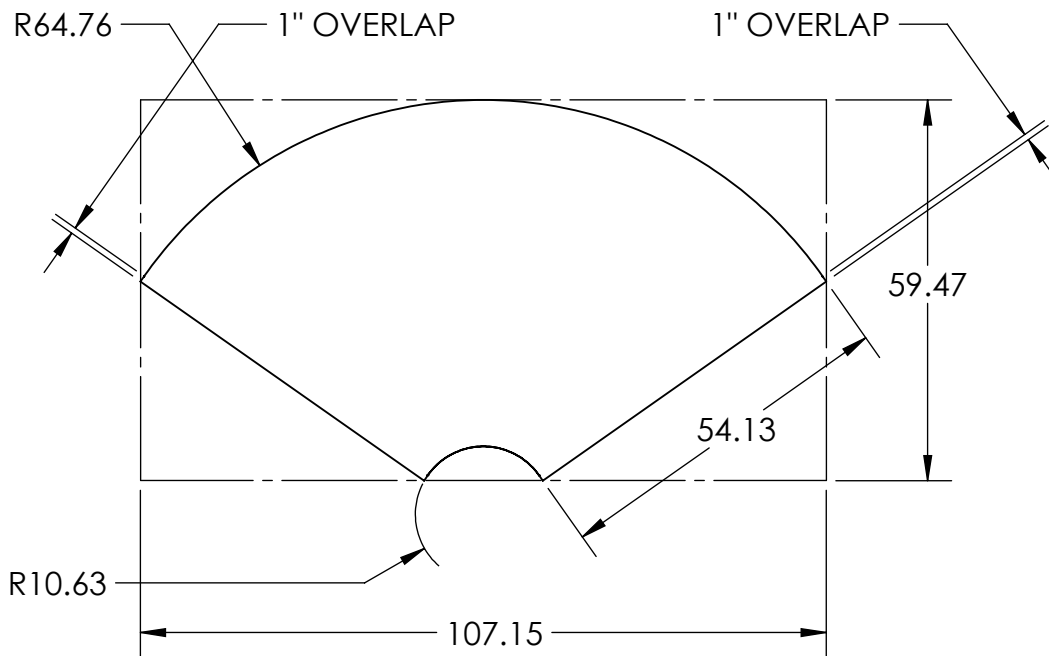

OUTSIDE 1/2 CONE

[JMB]
STAINLESS

JOB NAME:	40BBL UNI SIZE VOL. AND SHAPE	SALES ORDER / CONTACT:	JMB STAINLESS
TOLERANCE:	+/- 1/16"	MATERIAL:	304 S.S.
MODEL NUMBER:	40BBL UNI	DATE:	Tuesday, January 23, 2018
DRAWN BY:	O. W. D.	REVISION:	A

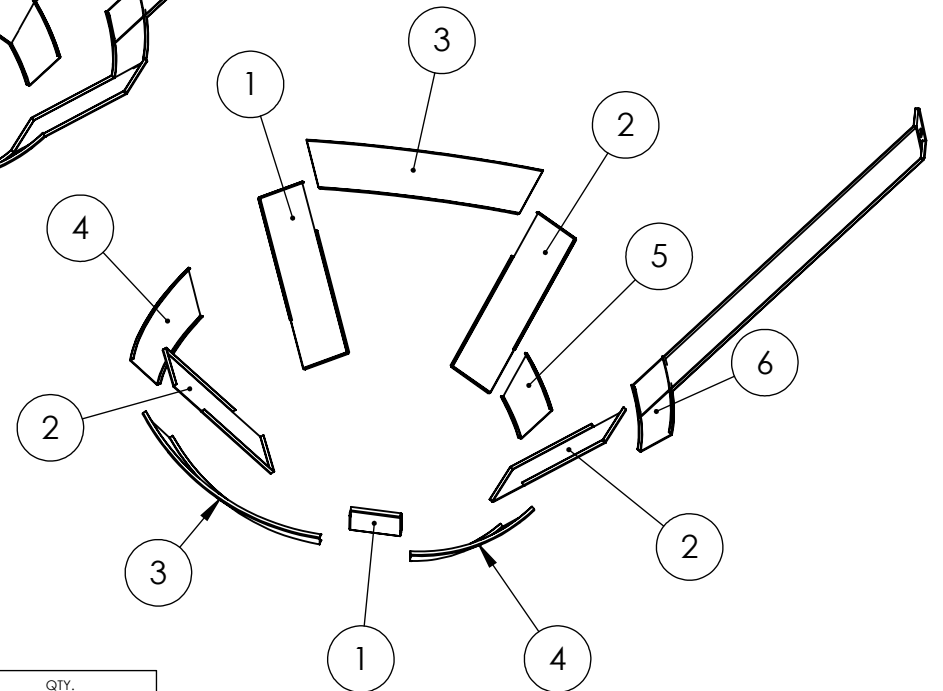
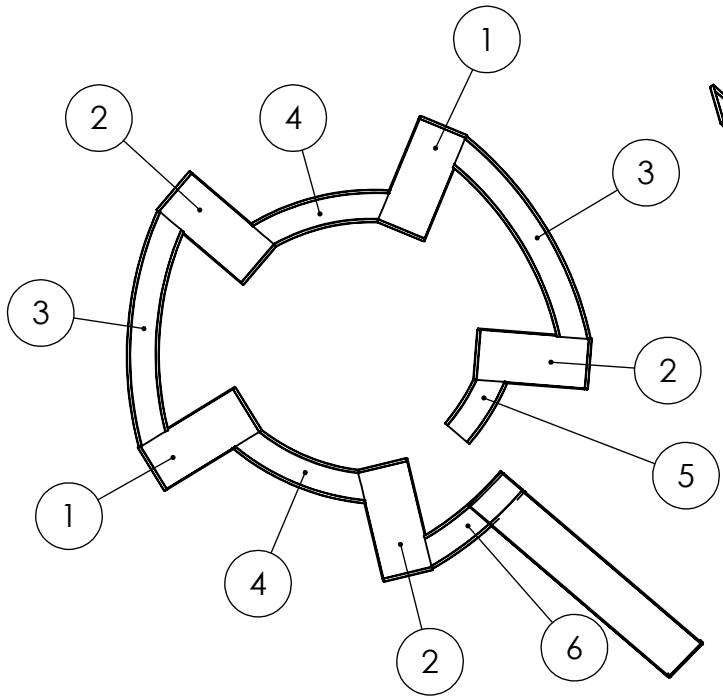
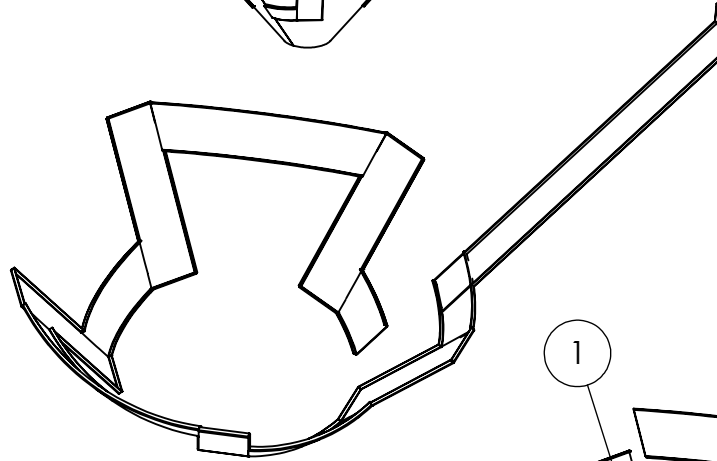
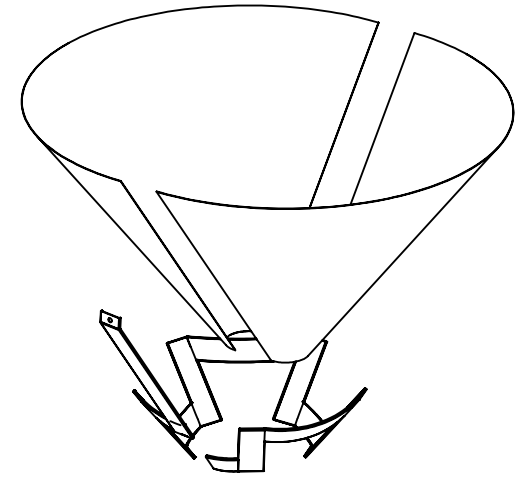
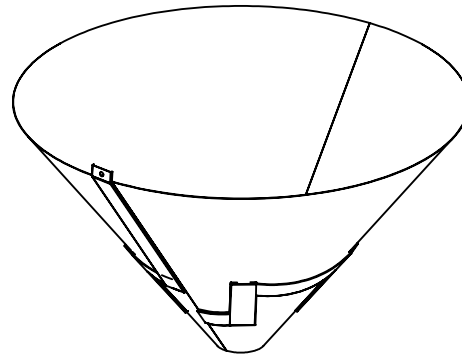
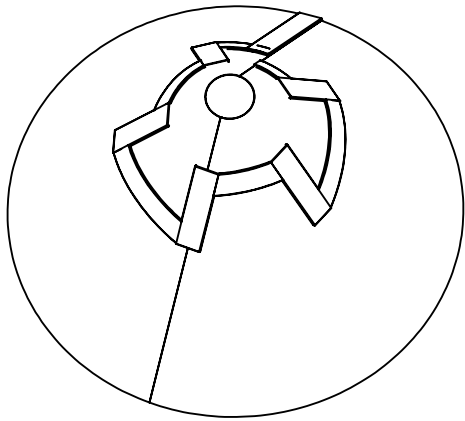

ITEM NO.	PART NUMBER	DESCRIPTION	QTY.
1	V1 - PATTERN	RIGHT	2
2	V1 - PATTERN	LEFT	3
3	V3.0 - PATTERN		2
4	V2.0 - PATTERN		2
5	V2.0 - INLET		1
6	V3.0 - OUTLT		1
7	integrated pattern		1

[JMB]
STAINLESS

JOB NAME: 40BBL UNI SIZE VOL. AND SHAPE	SALES ORDER / CONTACT: JMB STAINLESS
TOLERANCE: +/- 1/16"	MATERIAL: 304 S.S.
MODEL NUMBER: 40BBL UNI	REVISION: A
DRAWN BY: O. W. D.	DATE: Tuesday, January 23, 2018

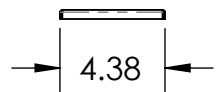

V-1.
(2) RIGHT
(3) LEFT

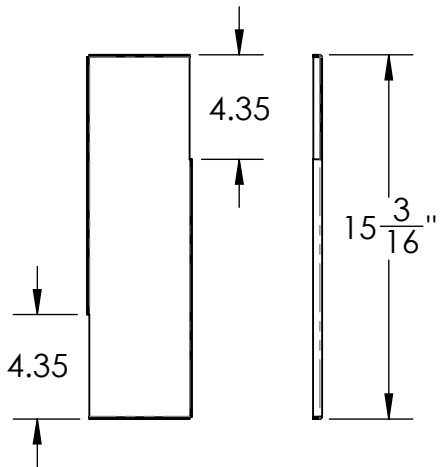

V-2.

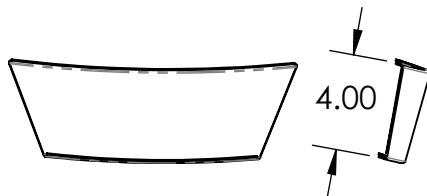
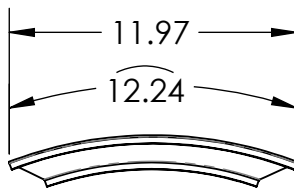
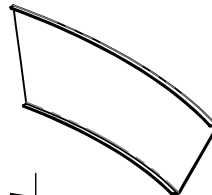

V-3.

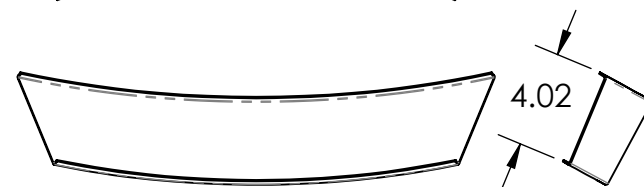
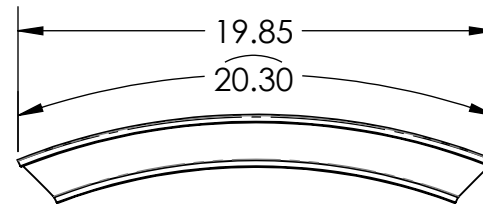
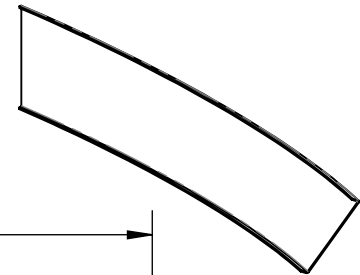

V-3-OUTLET.

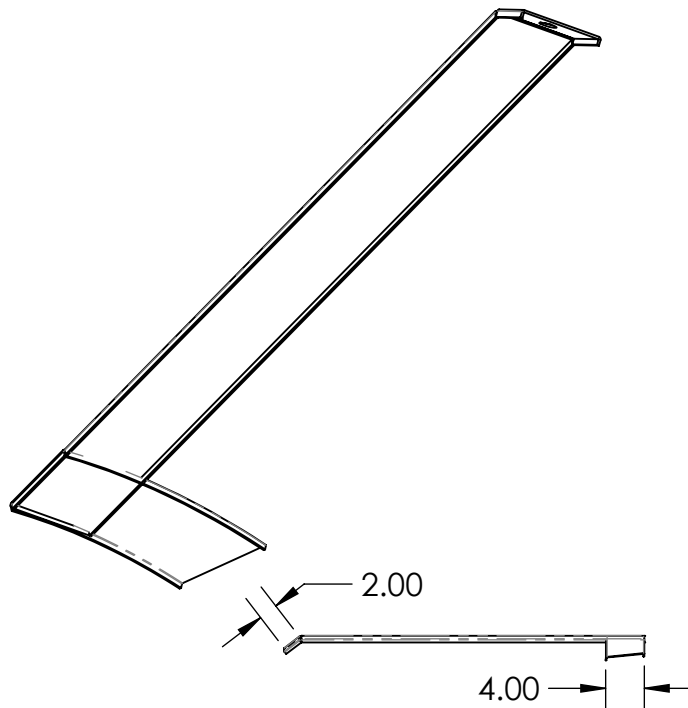
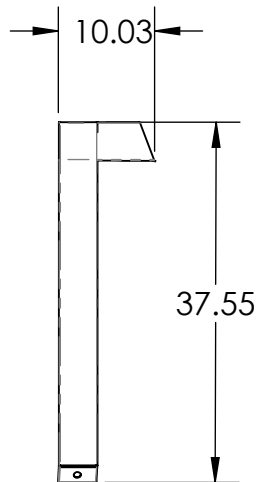

V-2-INLET.

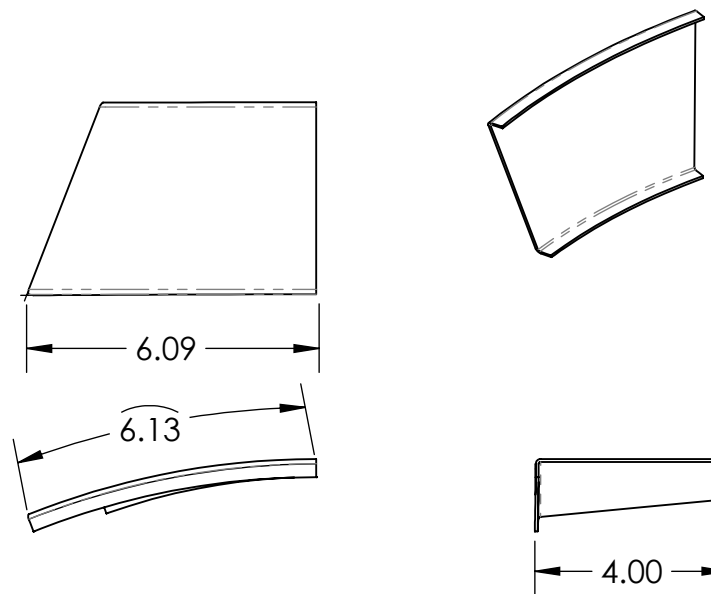

[JMB]
STAINLESS

JOB NAME:	40BBL UNI SIZE VOL. AND SHAPE	SALES ORDER / CONTACT:	JMB STAINLESS
TOLERANCE:	+/- 1/16"	MATERIAL:	304 S.S.
MODEL NUMBER:	40BBL UNI	DATE:	Tuesday, January 23, 2018
DRAWN BY:	O. W. D.	REVISION:	A

V-1.

(2) RIGHT
(3) LEFT

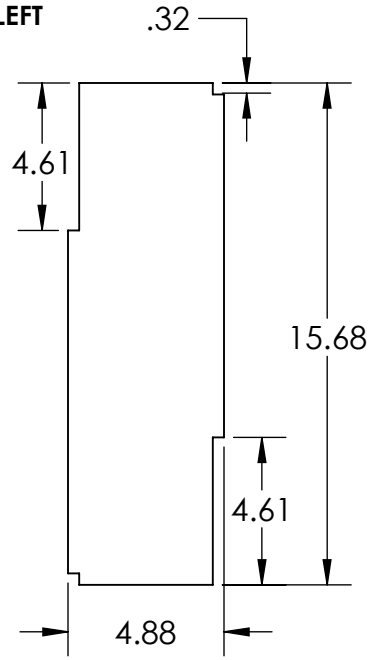

V-2.

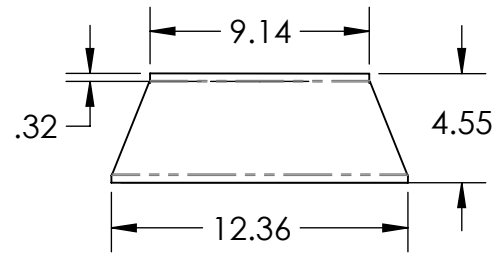
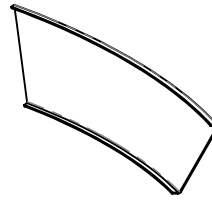

V-3.

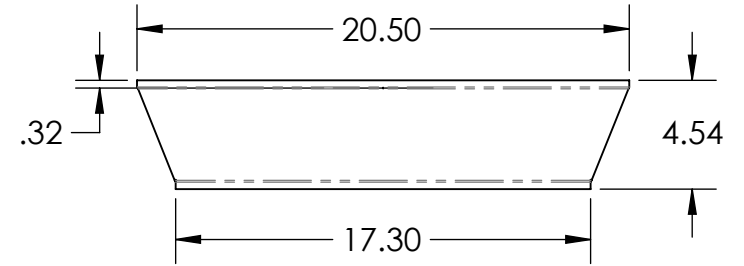
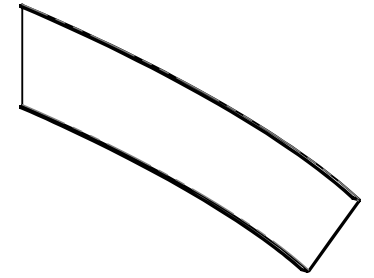

V-3-OUTLET.

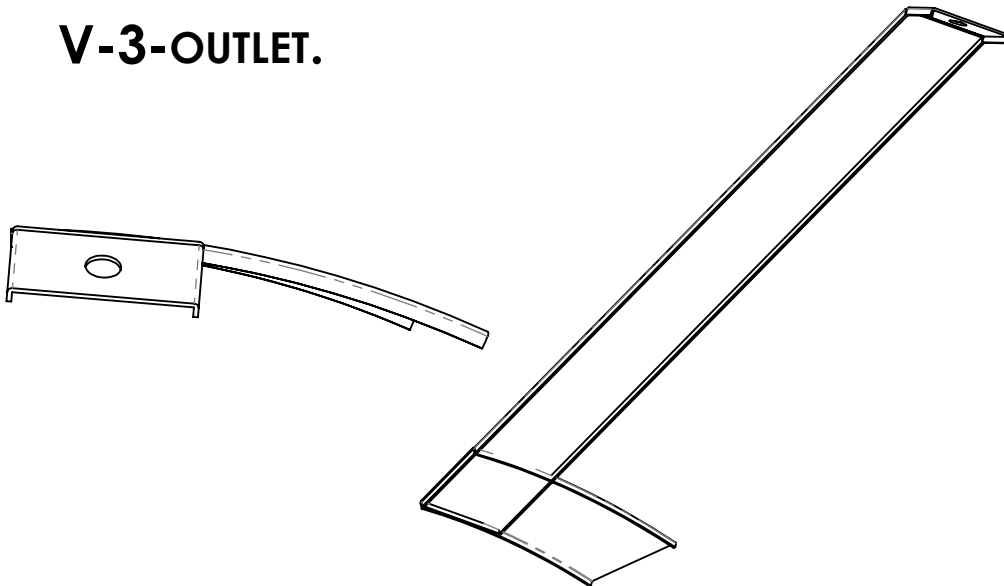

V-2-INLET.

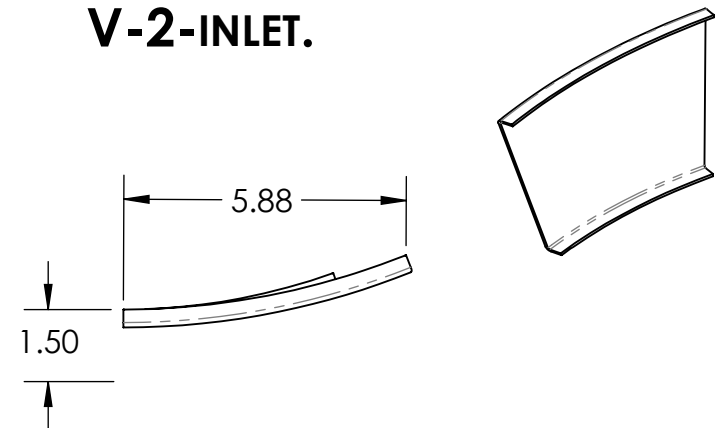

[JMB]
STAINLESS

JOB NAME:	40BBL UNI SIZE VOL. AND SHAPE	SALES ORDER / CONTACT:	JMB STAINLESS
TOLERANCE:	+/- 1/16"	MATERIAL:	304 S.S.
MODEL NUMBER:	40BBL UNI	REVISION:	A
DRAWN BY:	O. W. D.	DATE:	Tuesday, January 23, 2018

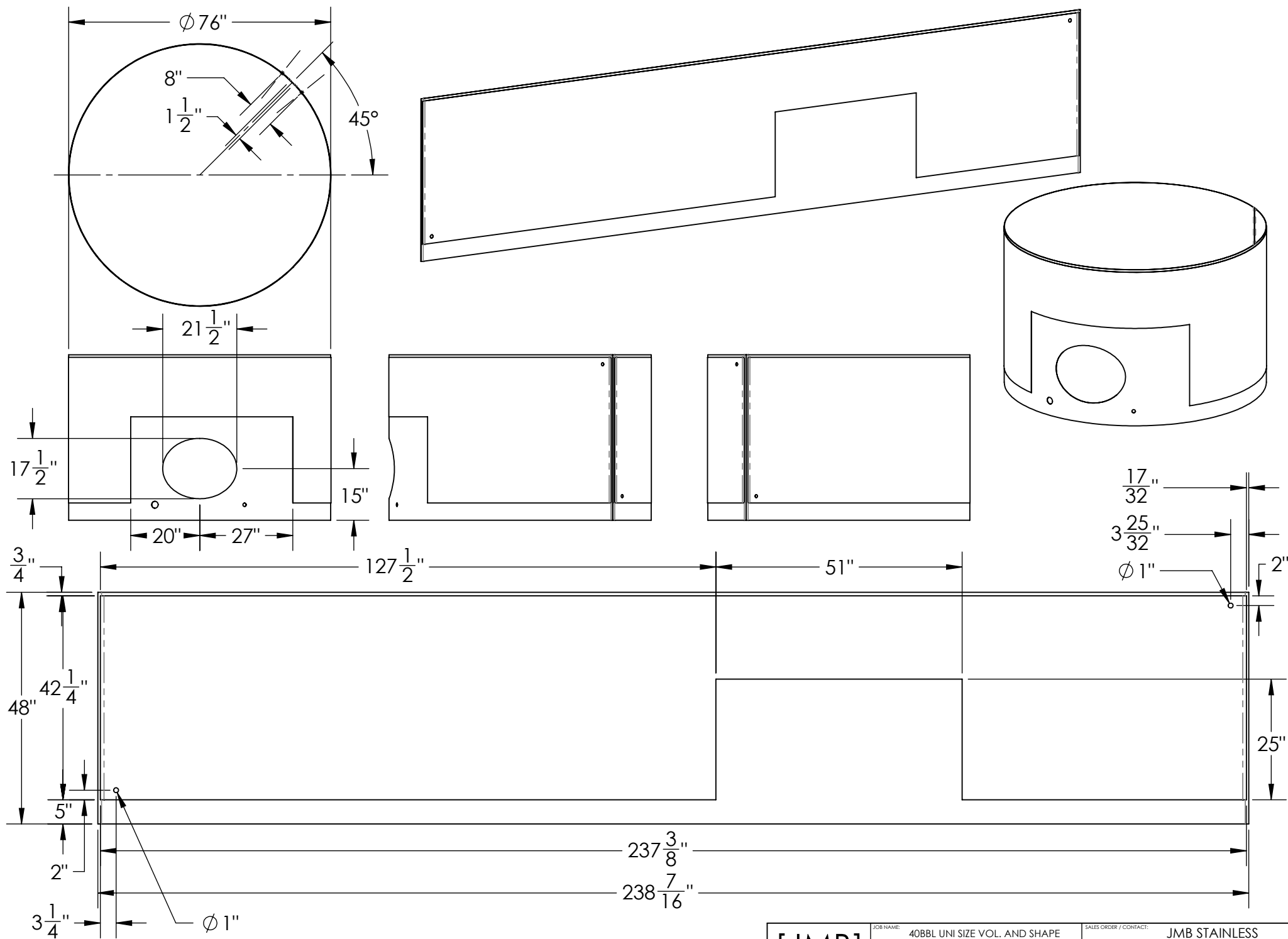

[JMB] STAINLESS	JOB NAME: 40BBL UNI SIZE VOL. AND SHAPE	SALES ORDER / CONTACT: JMB STAINLESS
	TOLERANCE: +/- 1/16"	MATERIAL: 304 S.S.
	MODEL NUMBER: 40BBL UNI	REVISION: A
	DRAWN BY: O. W. D.	DATE: Tuesday, January 23, 2018

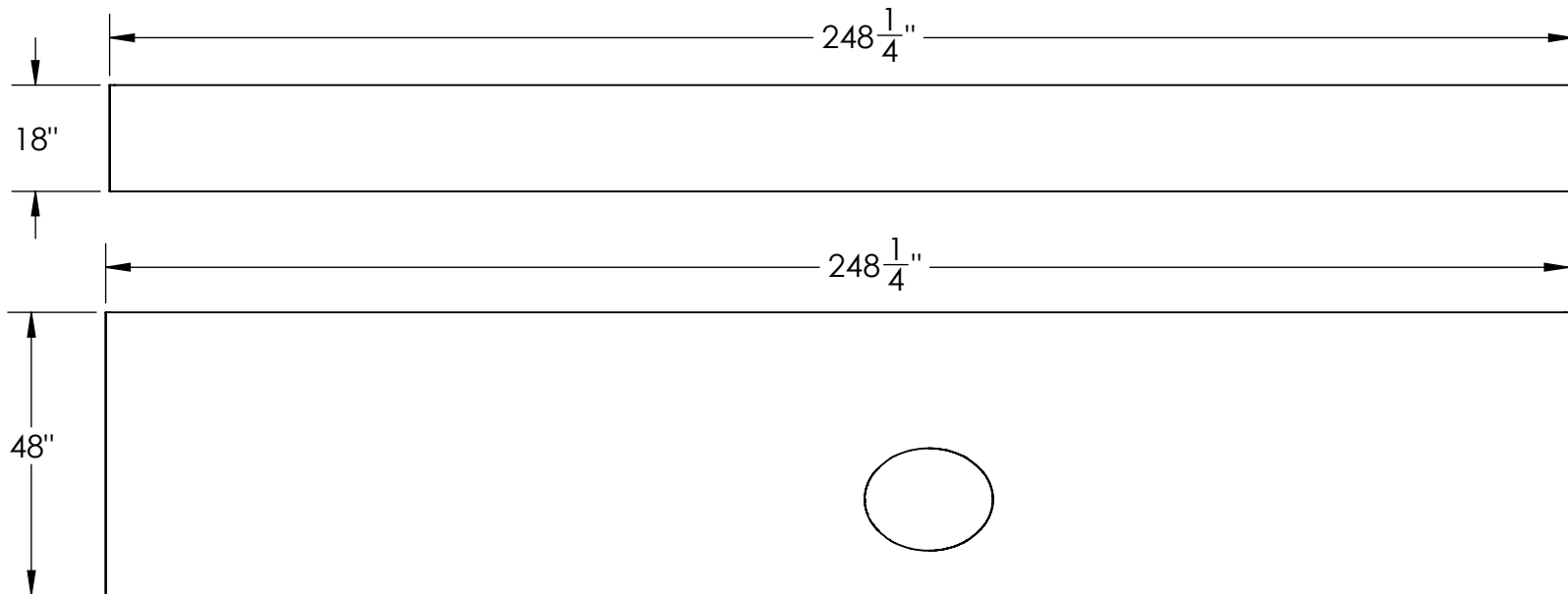
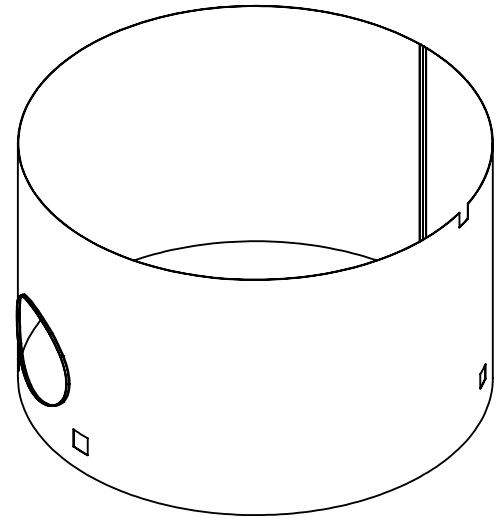
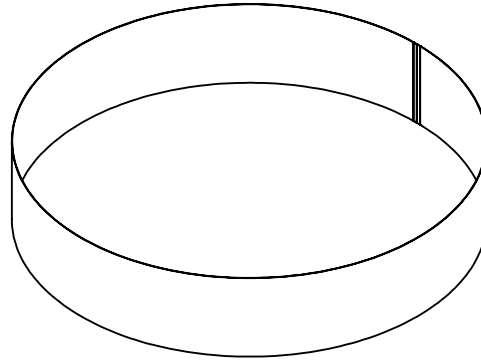
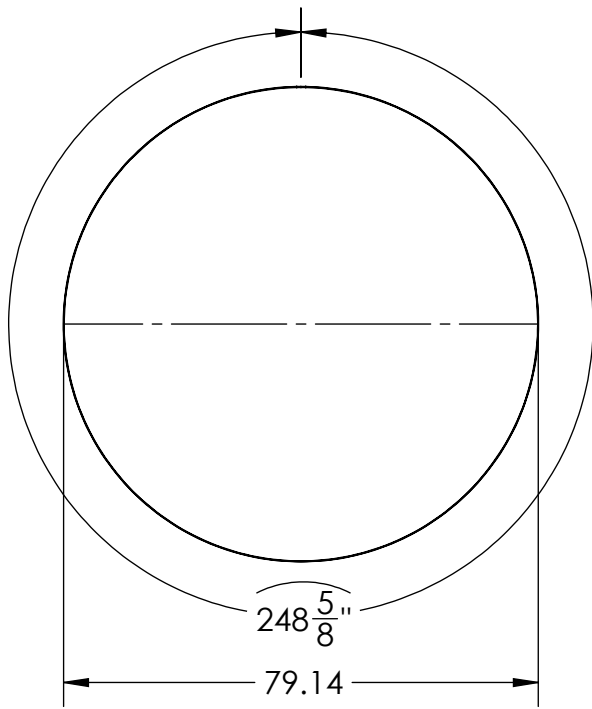

[JMB] STAINLESS	JOB NAME: 40BBL UNI SIZE VOL. AND SHAPE		SALES ORDER / CONTACT: JMB STAINLESS	
	TOLERANCE: +/- 1/16"	MATERIAL: 304 S.S.	MODEL NUMBER: 40BBL UNI	REVISION: A
	DRAWN BY: O. W. D.		DATE: Tuesday, January 23, 2018	

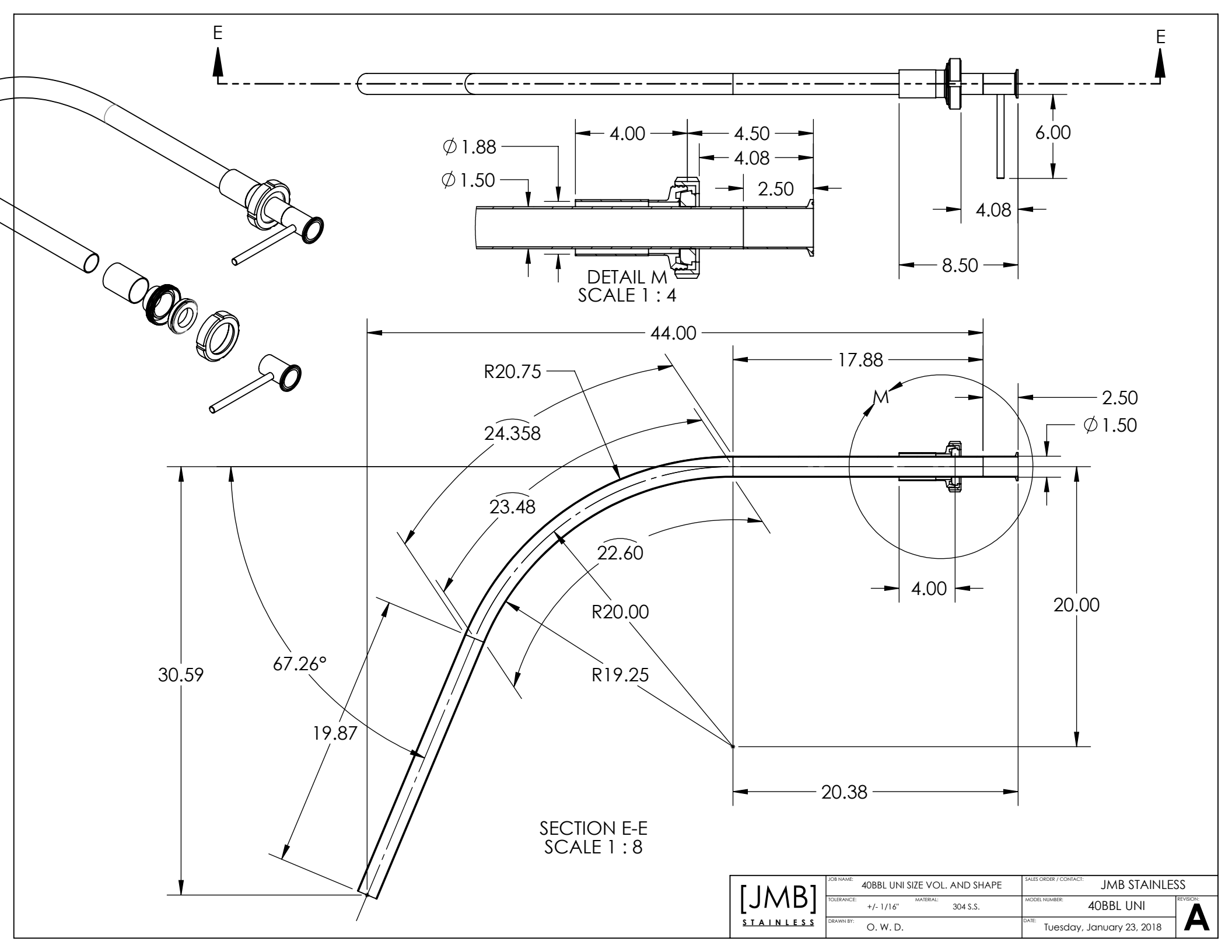

DETAIL M
SCALE 1 : 4

SECTION E-E
SCALE 1 : 8

[JMB]
STAINLESS

JOB NAME: 40BBL UNI SIZE VOL. AND SHAPE
TOLERANCE: +/- 1/16"
DRAWN BY: O. W. D.

MATERIAL: 304 S.S.

SALES ORDER / CONTACT: JMB STAINLESS
MODEL NUMBER: 40BBL UNI
DATE: Tuesday, January 23, 2018

REVISION: **A**