

TANK: 926.5 GALLONS  
 BASKET: 138.5 GALLONS

<b>[JMB]</b> STAINLESS	JOB NAME: TTANK 1K 76	SALES ORDER / CONTACT: JMB STAINLESS
	TOLERANCE: +/- 1/16"	MATERIAL: 304 S.S.
	MODEL NUMBER: TTNK1K 76	REVISION: <b>A</b>
DRAWN BY: O. W. D.	DATE: Tuesday, August 2, 2016	

DETAIL U  
SCALE 1 : 8

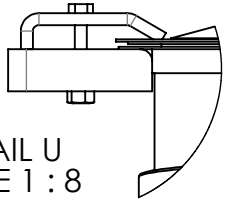

DETAIL V  
SCALE 1 : 8

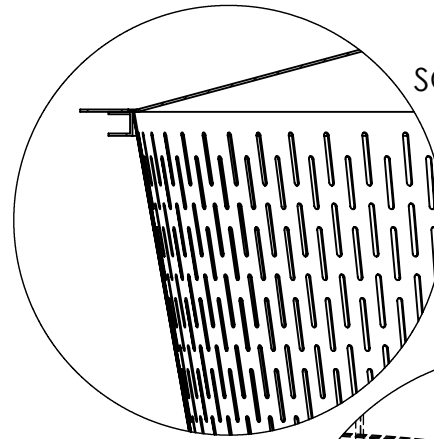

DETAIL R  
SCALE 1 : 8

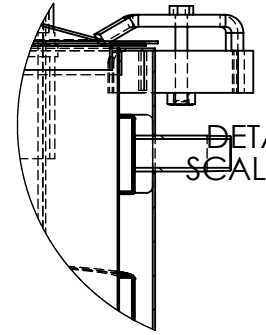

DETAIL T  
SCALE 1 : 8

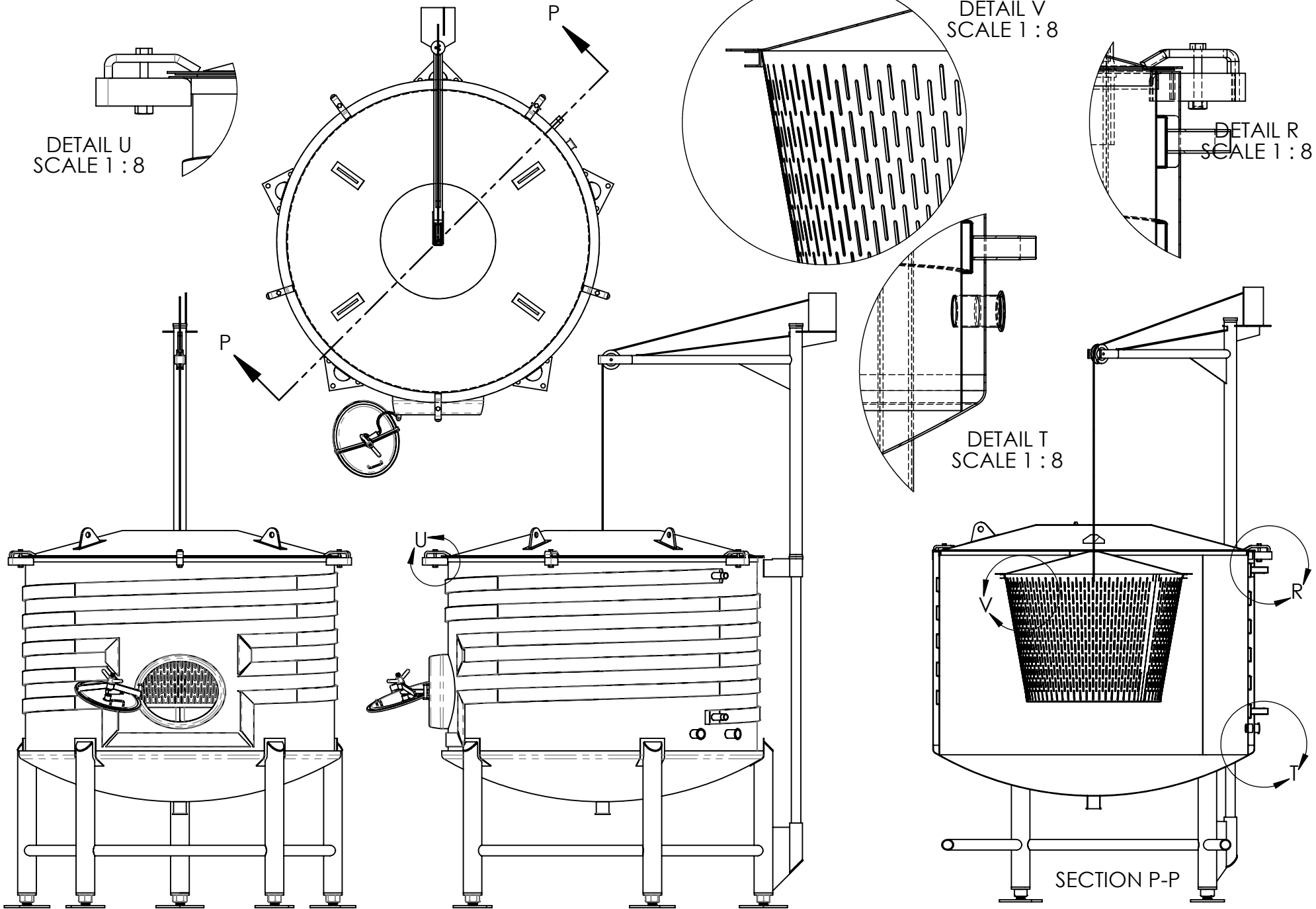
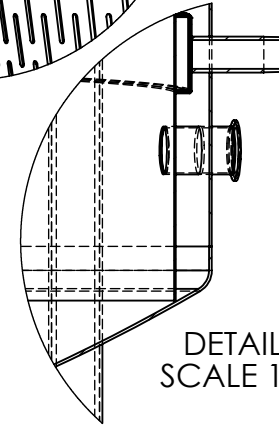

SECTION P-P

TANK: 926.5 GALLONS  
BASKET: 138.5 GALLONS

**[JMB]**  
STAINLESS

JOB NAME:	T TANK 1K 76	SALES ORDER / CONTACT:	JMB STAINLESS
TOLERANCE:	+/- 1/16"	MATERIAL:	304 S.S.
DRAWN BY:	O. W. D.	MODEL NUMBER:	TTNK1K 76
		DATE:	Tuesday, August 2, 2016

REVISION:  
**A**

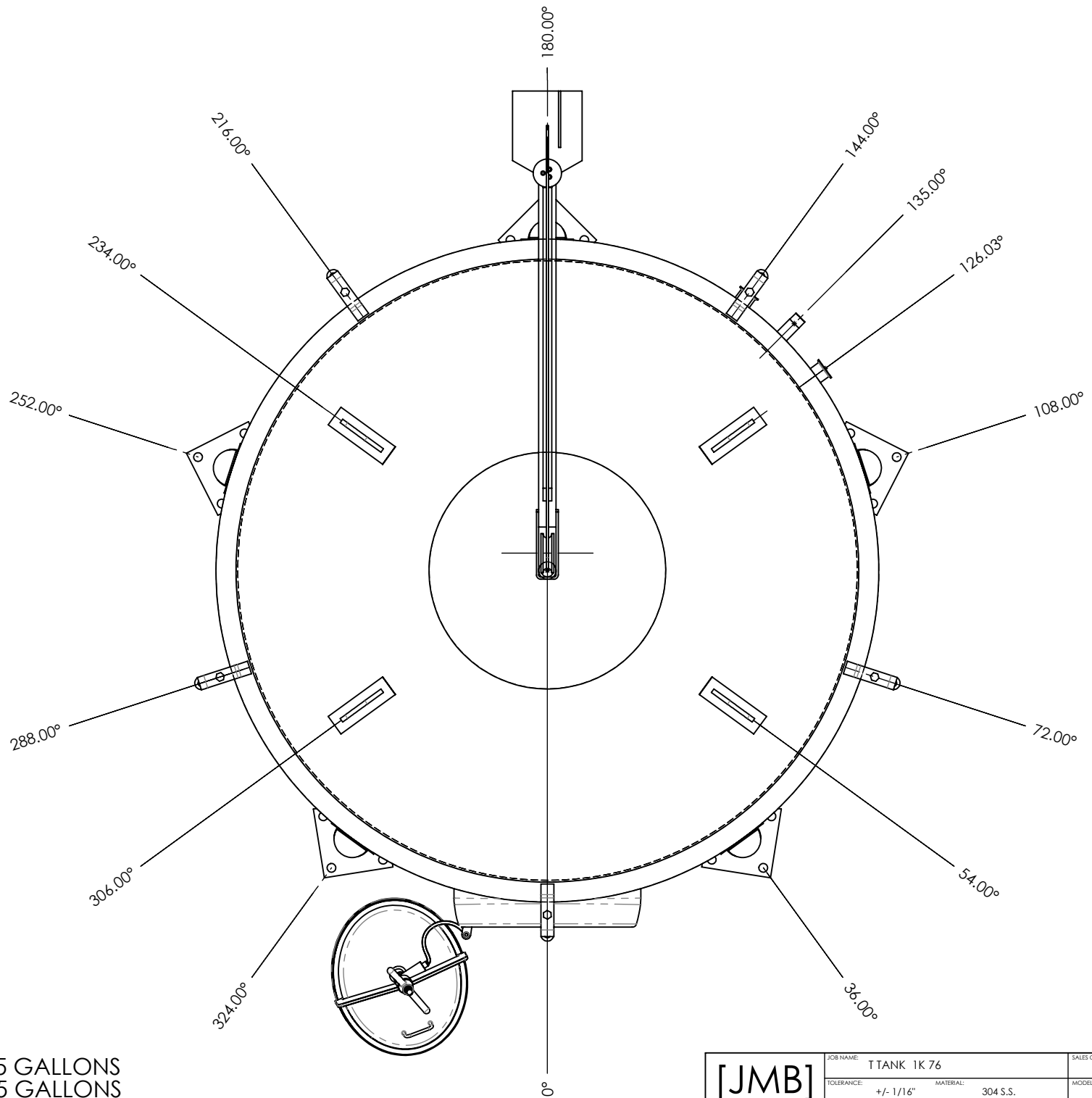

TANK: 926.5 GALLONS  
 BASKET: 138.5 GALLONS

<b>[JMB]</b> STAINLESS	JOB NAME: TTANK 1K 76	SALES ORDER / CONTACT: JMB STAINLESS
	TOLERANCE: +/- 1/16"    MATERIAL: 304 S.S.	MODEL NUMBER: TTNK1K 76
	DRAWN BY: O. W. D.	DATE: Tuesday, August 2, 2016

REVISION: **A**

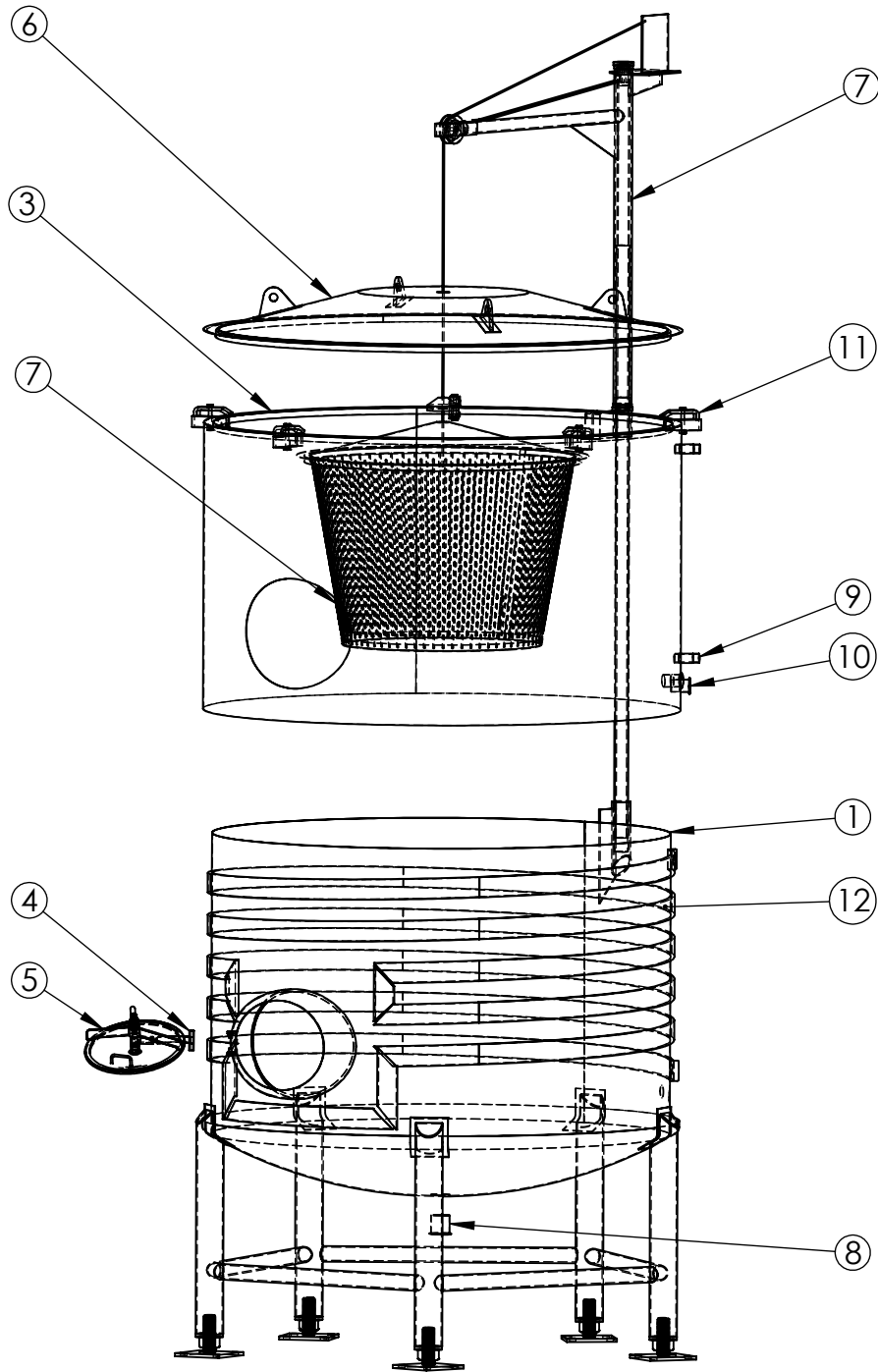

ITEM NO.	PART NUMBER	QTY.
1	BOTTOM OF TANK	1
	BASE ASSEMBLY	1
	LEG ASSEMBLY	5
	LEG TUBE	1
	LEG TOP CAP	1
	LEG BACKER PLATE	1
	-	-
	NUT CAP WELDMENT	1
	LEG BTM RING	1
	LEG NUT	1
	FOOT PAD WELDMENT	1
	FOOT PAD	1
	THREADED FOOT ROD	1
	CROSS BRACE	5
	BARREL HEAD WELDMENT	1
	BOTTOM HEAD	1
	BARREL 1	1
	-	-
	- MAN-WAY 21 1-2 IN. X 17 1-2 IN.	1
2	WRAP 1.1	1
	-	-
3	ROLLED L CHANNEL	1
	-	-
4	- MAN-WAY DOOR HINGE - ASSEM	1
	- MAN-WAY RNDBAR	1
	- MAN-WAY HNGBAR	1
5	- MAN-WAY DOOR - ASSEM	1
	- MAN-WAY DOOR	1
	- MAN-WAY BUSHING	1
	- MAN-WAY BAR	1
	- MAN-WAY WASHER	1
	- MAN-WAY HNGLOC	1
6	TOP HEAD ASSEMBLY	1
	TOP HEAD	1
	LIFTING LUGS	5
	HORIZ LUG BACKER PAD	1
	-	-
	TOP	1
	CONE HEAD - ROLLED L	1
	-	-
7	TEA CRANE	1
8	3in Ferrule TT	1
9	1.1-2x8 S40 W NIPPLE 304 TT	2
10	2in Ferrule TT	2
11	RMVBL TP CLAMP - SA	5
	RT CLMP B	1
	-	-
	RT CLMP A	1
	-	-
	RT CLAMP BOLT	1
	RT CLAMP NUT	1
12	HELIX JACKET - ASSEM B	1
	HELICAL JACKET 1 B	24
	HELICAL JACKET ZIGZAG STEP45 B	2
	HELICAL JACKET ENDPLATE B	2
	HELICAL JACKET Z B	1
	HELICAL JACKET ZR B	1
	HELICAL JACKET ZL B	1

**[JMB]**  
STAINLESS

JOB NAME: T TANK 1K 76  
 TOLERANCE: +/- 1/16" MATERIAL: 304 S.S.  
 DRAWN BY: O. W. D.

SALES ORDER / CONTACT: JMB STAINLESS  
 MODEL NUMBER: TTNK1K 76  
 DATE: Tuesday, August 2, 2016

REVISION: **A**

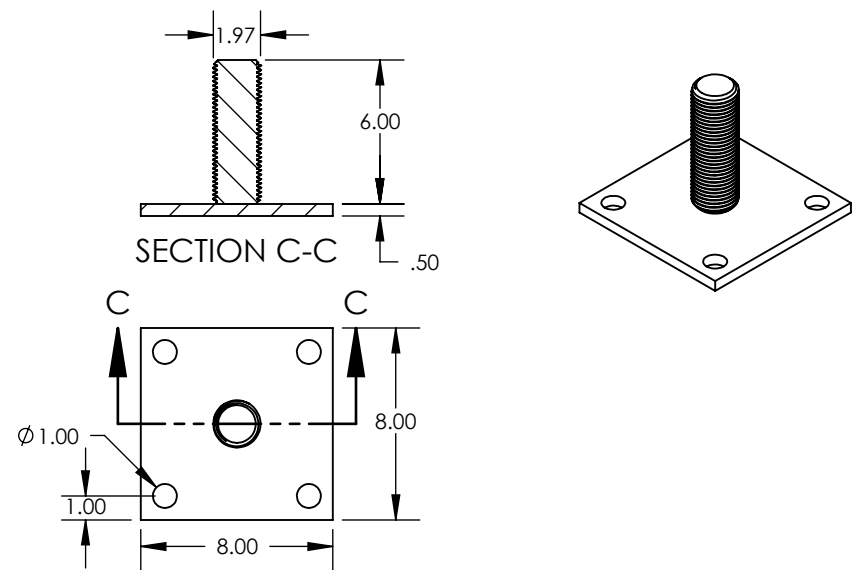
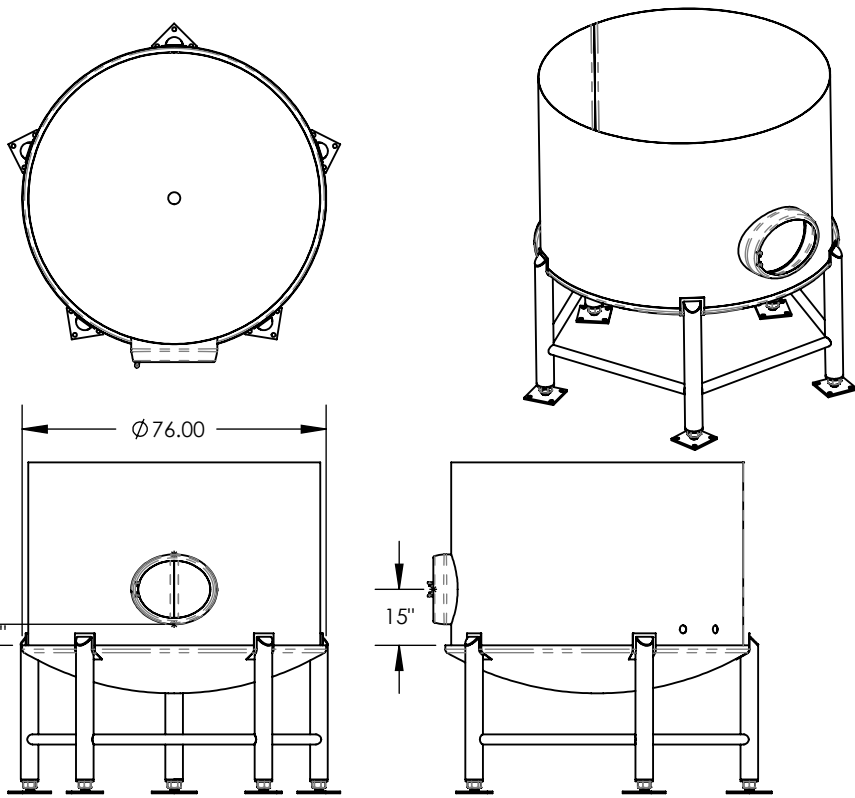
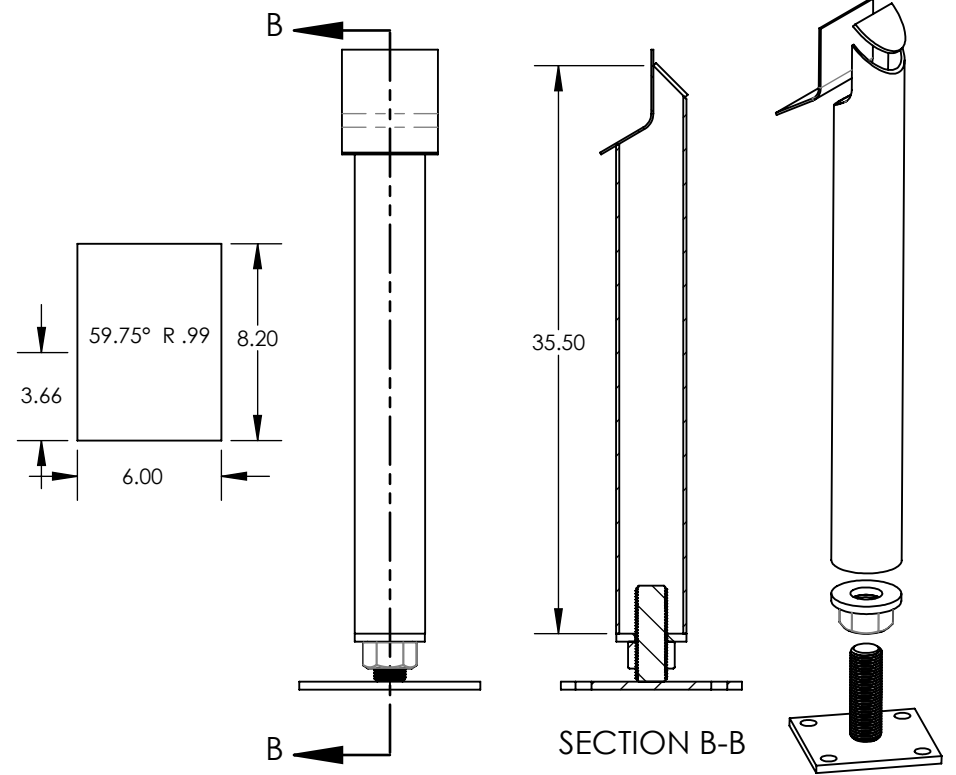
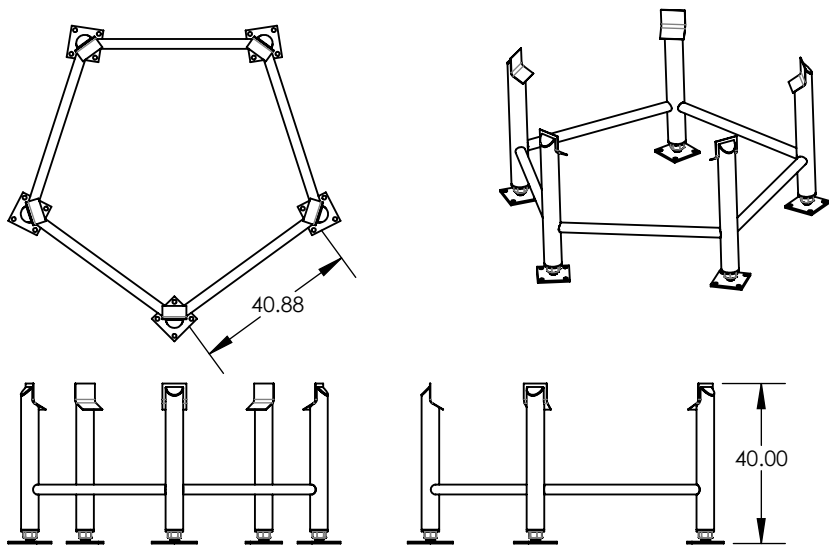

**[JMB]**  
STAINLESS

JOB NAME: TTANK 1K 76

TOLERANCE: +/- 1/16" MATERIAL: 304 S.S.

DRAWN BY: O. W. D.

SALES ORDER / CONTACT: JMB STAINLESS

MODEL NUMBER: TTNK1K 76

DATE: Tuesday, August 2, 2016

REVISION: **A**

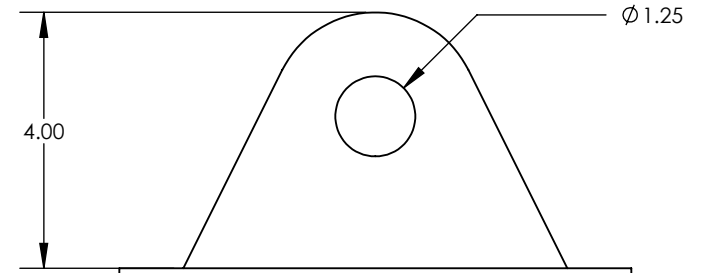
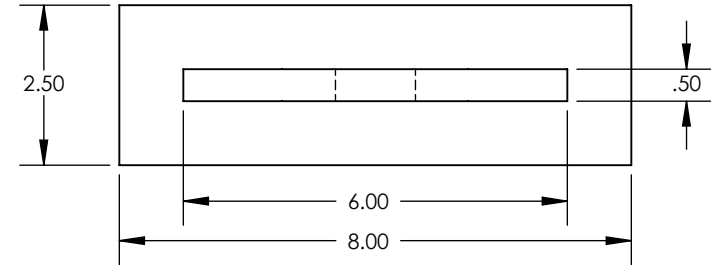
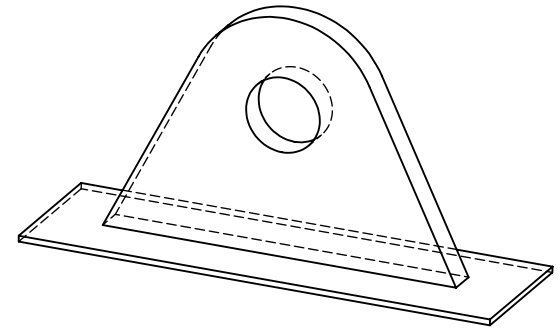
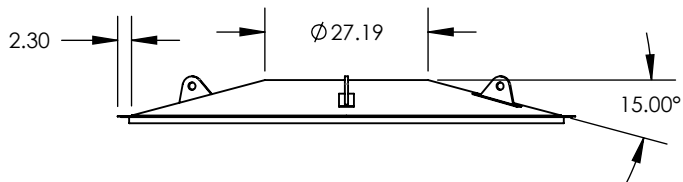
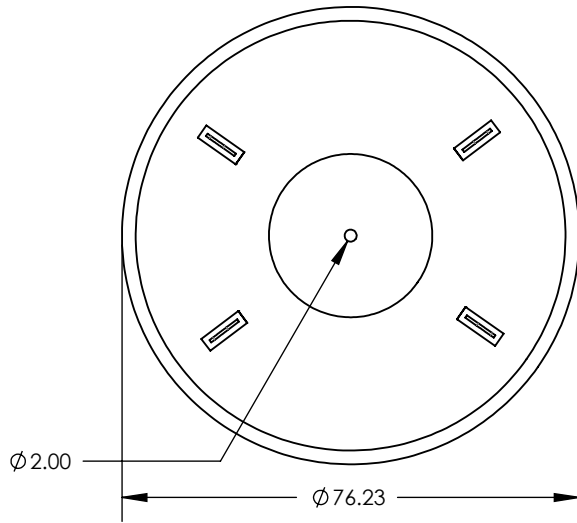
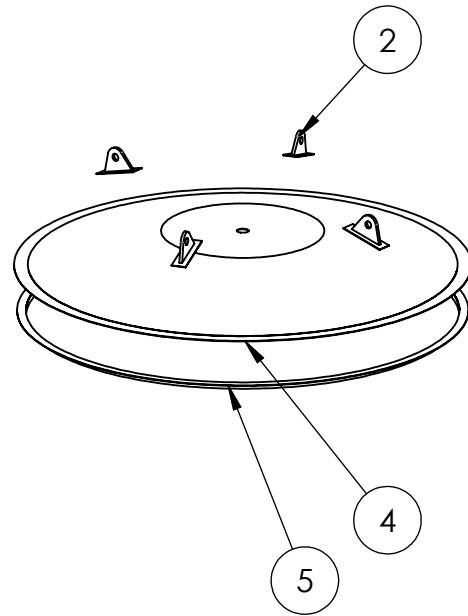
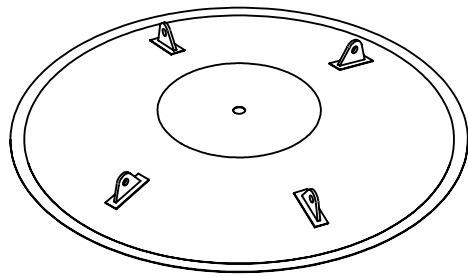

ITEM NO.	PART NUMBER	DESCRIPTION	QTY.
1	TOP HEAD		1
2	LIFTING LUGS		5
3	HORIZ LUG BACKER PAD		1
		Sheet	-
4	TOP		1
5	CONE HEAD - ROLLED L		1
		Sheet	-

**[JMB]**  
STAINLESS

JOB NAME: TTANK 1K 76	SALES ORDER / CONTACT: JMB STAINLESS
TOLERANCE: +/- 1/16"	MATERIAL: 304 S.S.
MODEL NUMBER: TTNK1K 76	REVISION: <b>A</b>
DRAWN BY: O. W. D.	DATE: Tuesday, August 2, 2016

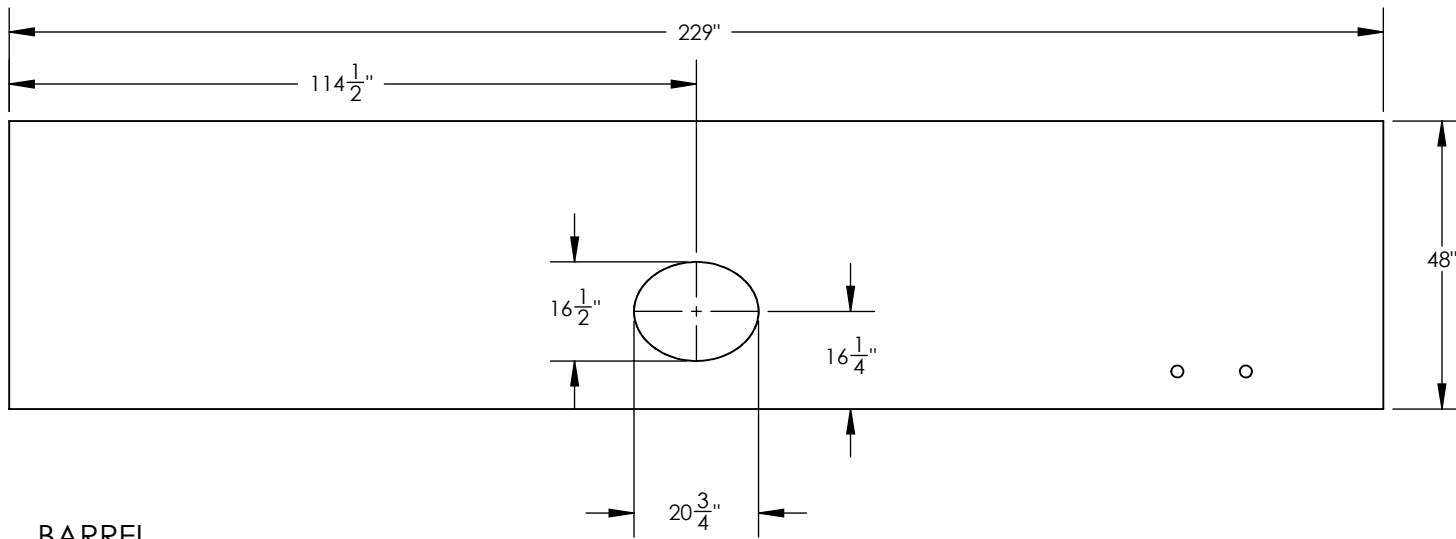

BARREL

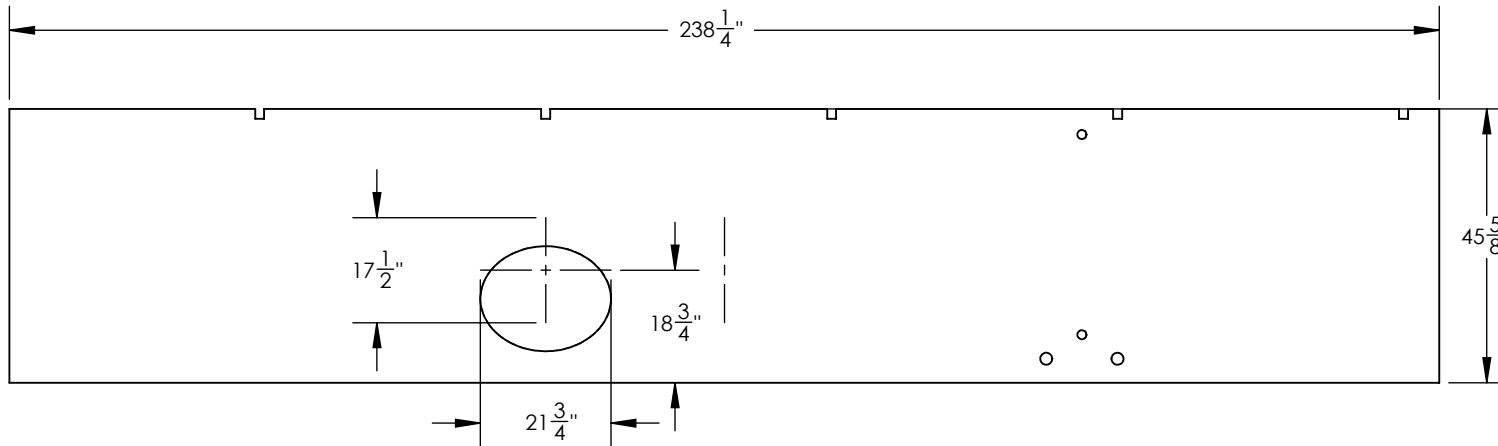
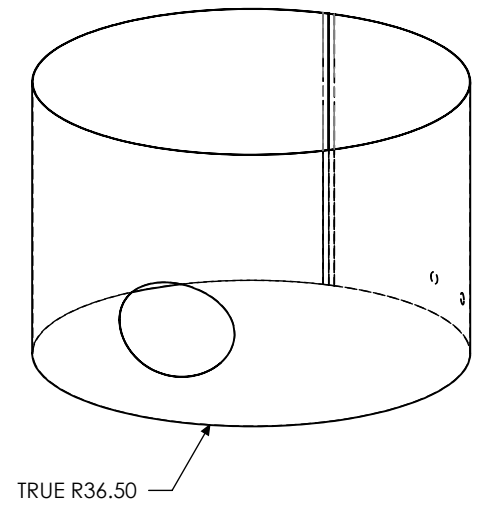

WRAP

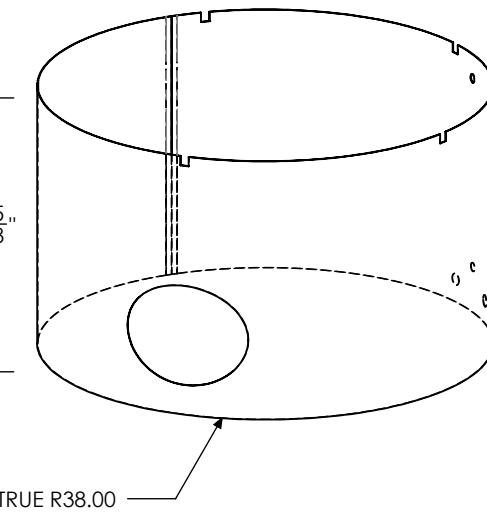

**[JMB]**  
STAINLESS

JOB NAME: TTANK 1K 76  
 TOLERANCE: +/- 1/16"  
 MATERIAL: 304 S.S.  
 DRAWN BY: O. W. D.

SALES ORDER / CONTACT: JMB STAINLESS  
 MODEL NUMBER: TTNK1K 76  
 DATE: Tuesday, August 2, 2016

REVISION: **A**

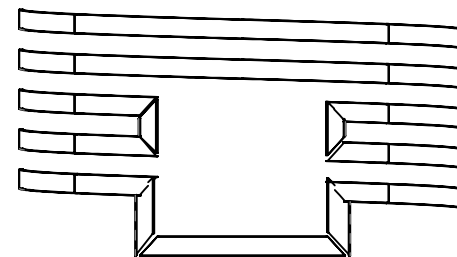
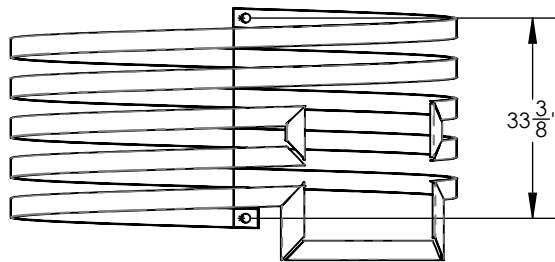
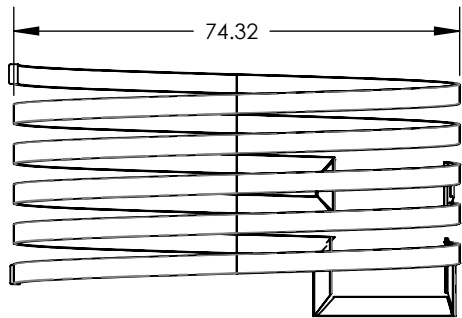
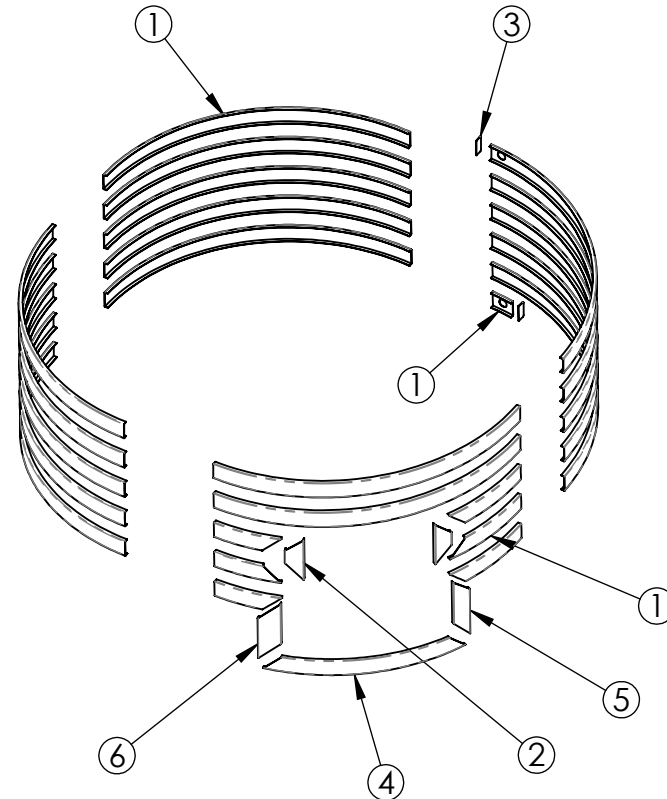
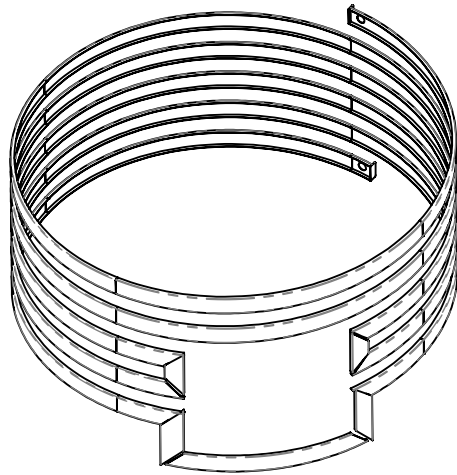
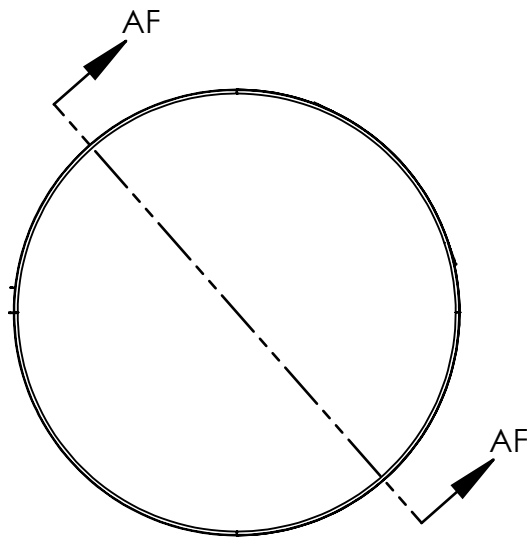

SECTION AF-AF

ITEM NO.	PART NUMBER	DESCRIPTION	QTY.
1	HELICAL JACKET 1 B		24
2	HELICAL JACKET ZIGZAG STEP45 B		2
3	HELICAL JACKET ENDPLATE B		2
4	HELICAL JACKET Z B		1
5	HELICAL JACKET ZR B		1
6	HELICAL JACKET ZL B		1

**[JMB]**  
STAINLESS

JOB NAME: TTANK 1K 76	SALES ORDER / CONTACT: JMB STAINLESS
TOLERANCE: +/- 1/16"	MATERIAL: 304 S.S.
MODEL NUMBER: TTNK1K 76	REVISION: <b>A</b>
DRAWN BY: O. W. D.	DATE: Tuesday, August 2, 2016



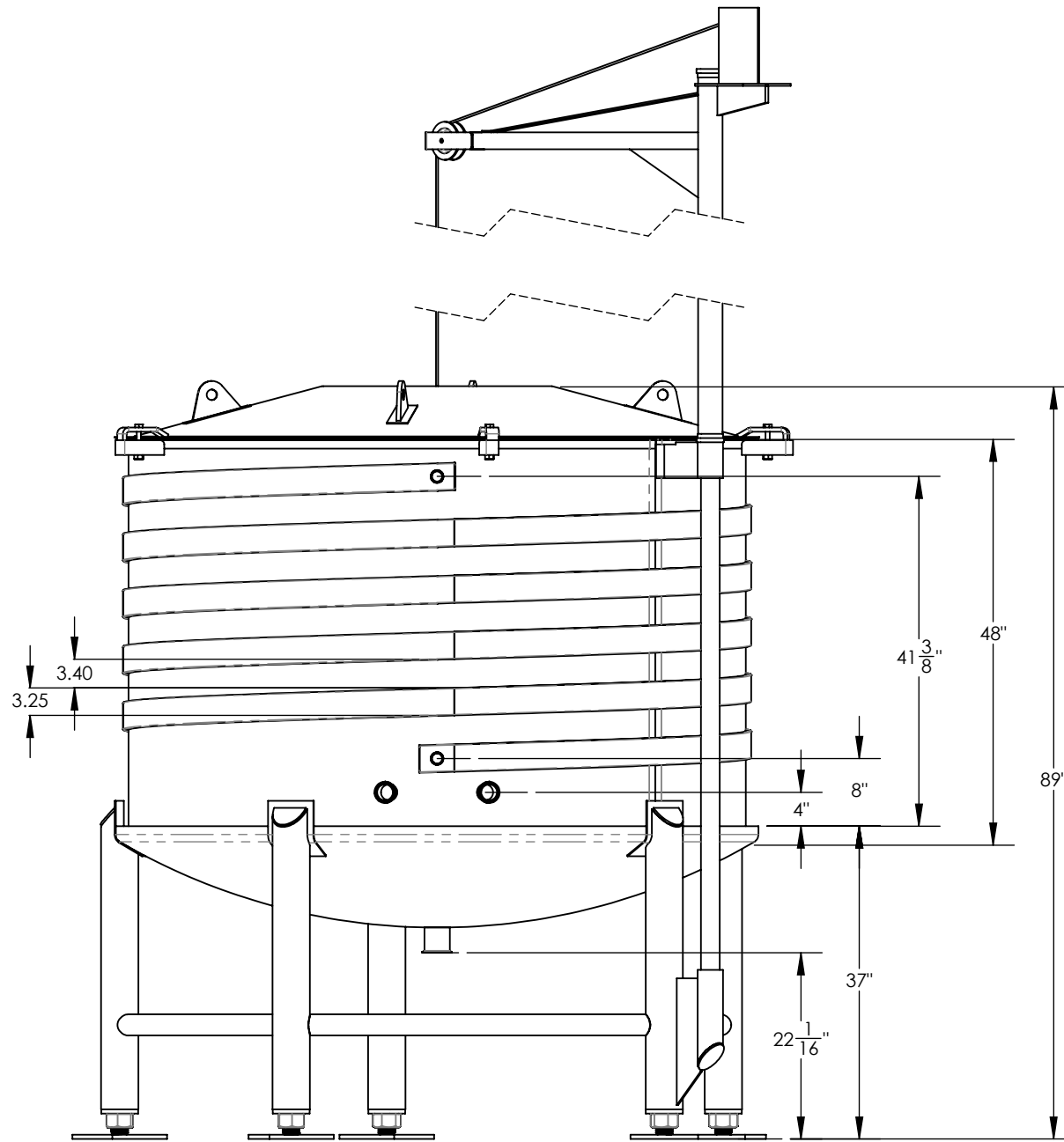

<b>[JMB]</b> STAINLESS	JOB NAME: TTANK 1K 76	SALES ORDER / CONTACT: JMB STAINLESS
	TOLERANCE: +/- 1/16" MATERIAL: 304 S.S.	MODEL NUMBER: TTNK1K 76
	DRAWN BY: O. W. D.	DATE: Tuesday, August 2, 2016
	REVISION: <b>A</b>	