

SECTION A-A

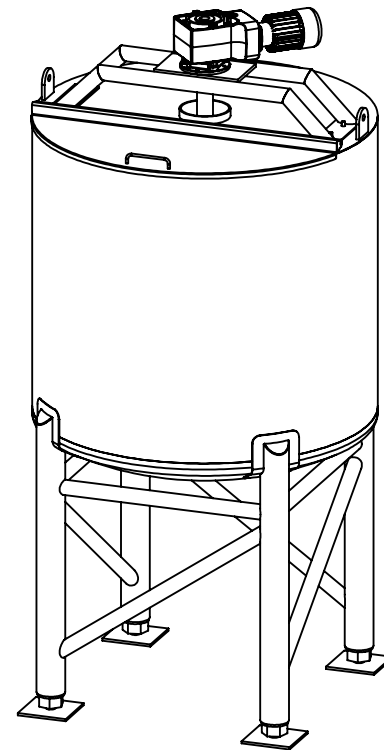

[RAD] STAINLESS	JOB NAME: ORTHO VIEW	SALES ORDER / CONTACT: RAD STAINLESS
	TOLERANCE: +/- 1/16" MATERIAL: 304 S.S.	MODEL NUMBER: 48 D. - TANK
	DRAWN BY: O. W. D.	DATE: Monday, July 8, 2019

REVISION: **A**

#	NAME	DESCRIPTION	Q
1	ICT - 54 D. - BARREL		1
2	ICT - 54 D. - HEAD		1
3	ICT - 54 D. - LEG		4
4	2.5 in. TC		1
5	ICT - 54 D. - FOOT PAD		4
6	ICT - 54 D. - LID TOP		1
7	ICT - 54 D. - CB Diagonal		4
8	ICT - 54 D. - FLIP TOP		1
9	ICT - 54 D. - CB Horizontal		4
10	ICT - 54 D. - Lift LUG		2
11	NORD MTR Solid		1
12	ICT - 54 D. - BRIDGE Plate		1
13	ICT - 54 D. - BRIDGE Leg		2
14	ICT - 54 D. - BRIDGE Foot pad		2
15	FULL SWEEP AGITATION 1 - ict		1
16	SPIDER 2in. Pipe		1
17	SPIDER BUSHING 2in. Pipe		1

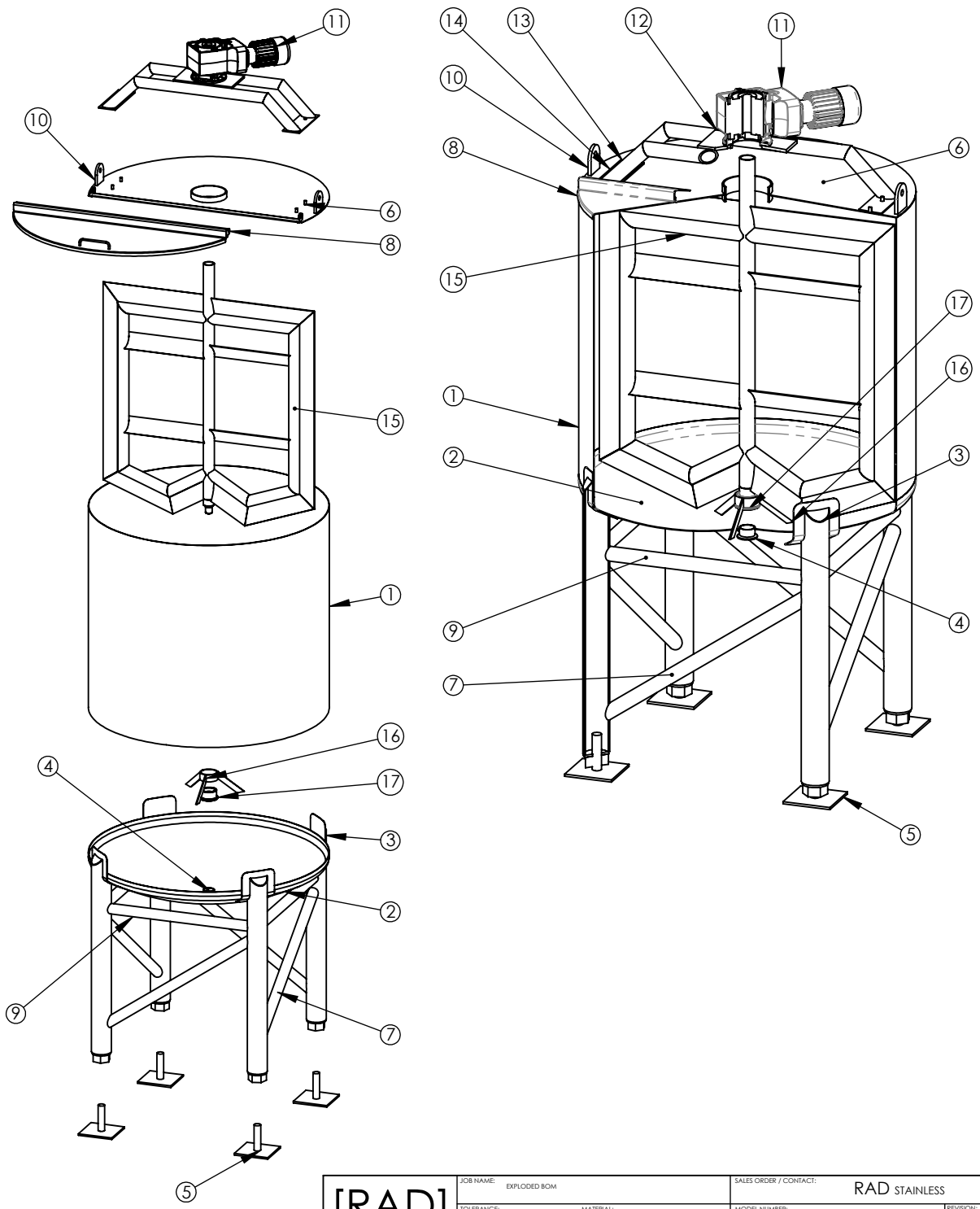

[RAD] STAINLESS	JOB NAME: EXPLODED BOM		SALES ORDER / CONTACT: RAD STAINLESS	
	TOLERANCE: +/- 1/16"	MATERIAL: 304 S.S.	MODEL NUMBER: 48 D. - TANK	REVISION: A
	DRAWN BY: O. W. D.		DATE: Monday, July 8, 2019	

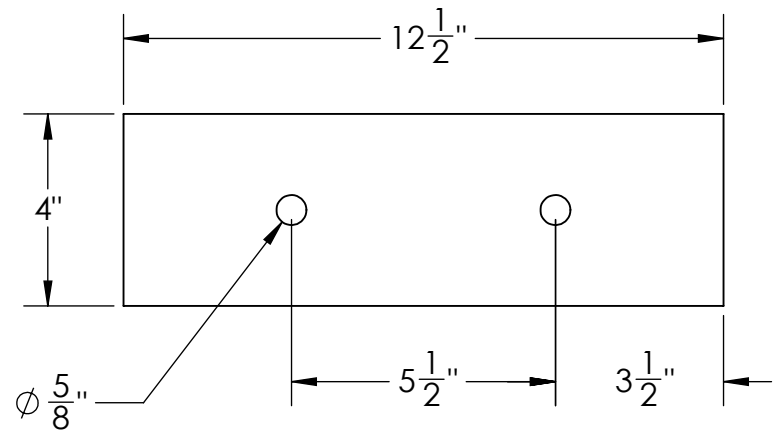
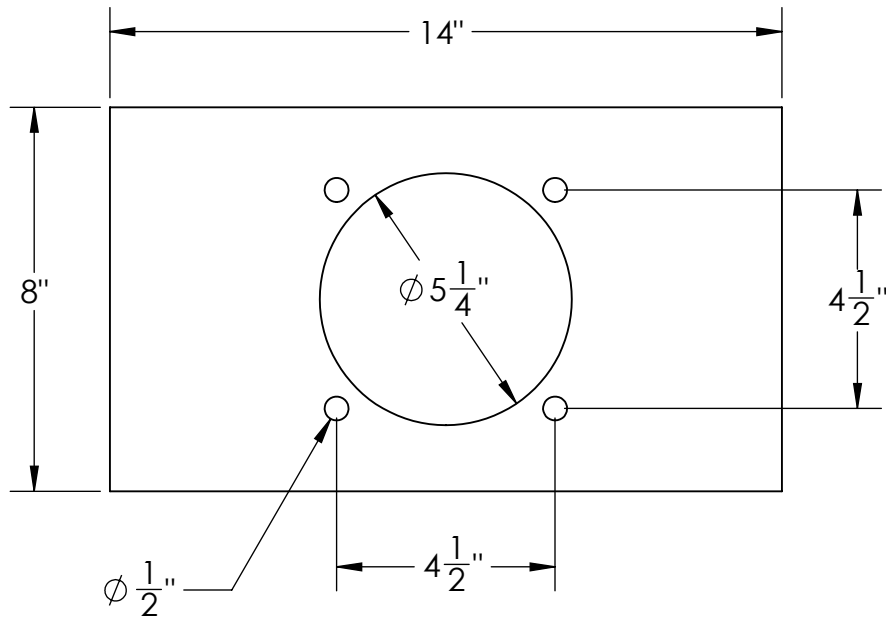
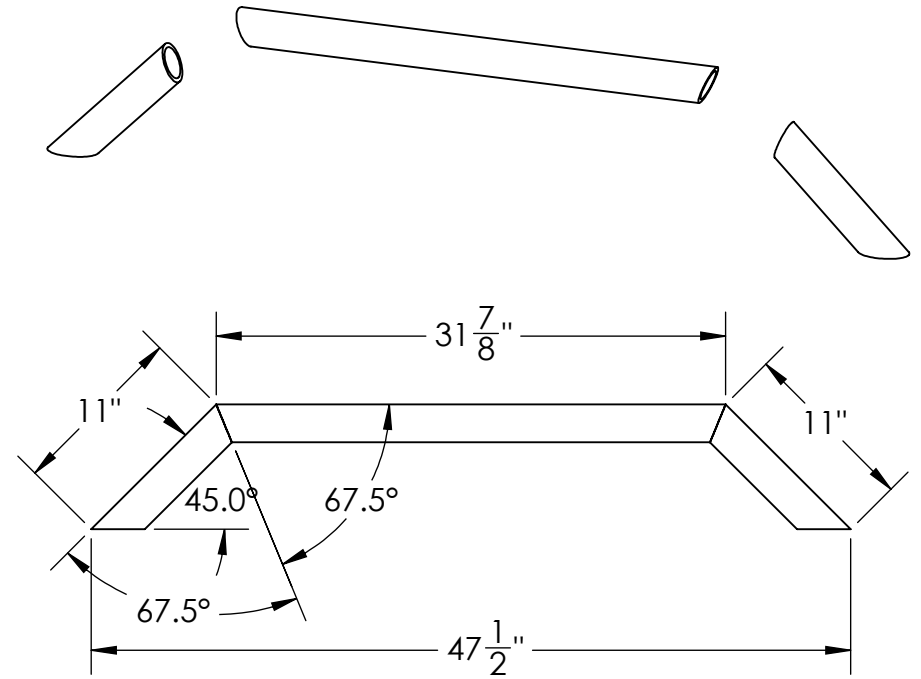
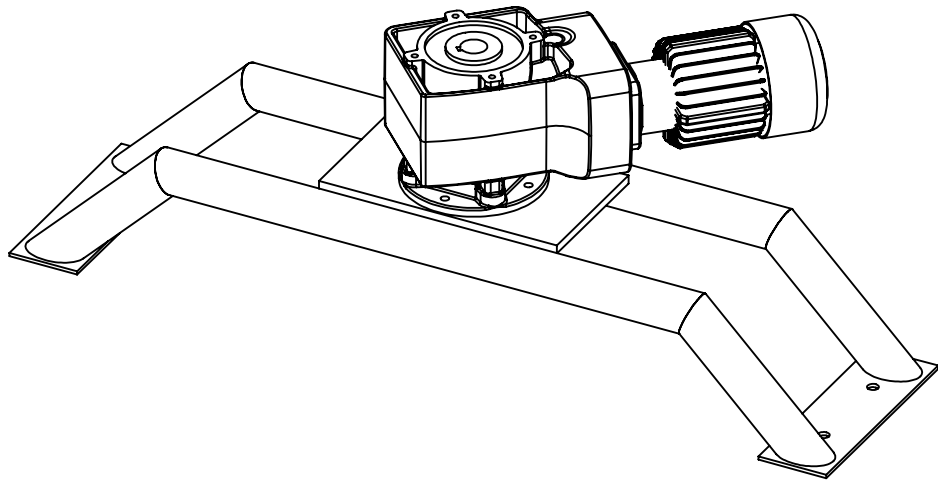

[RAD]
STAINLESS

JOB NAME: BRIDGE
TOLERANCE: +/- 1/16" MATERIAL: 304 S.S.
DRAWN BY: O. W. D.

SALES ORDER / CONTACT: RAD STAINLESS
MODEL NUMBER: 48 D. - TANK
DATE: Monday, July 8, 2019

REVISION:
A

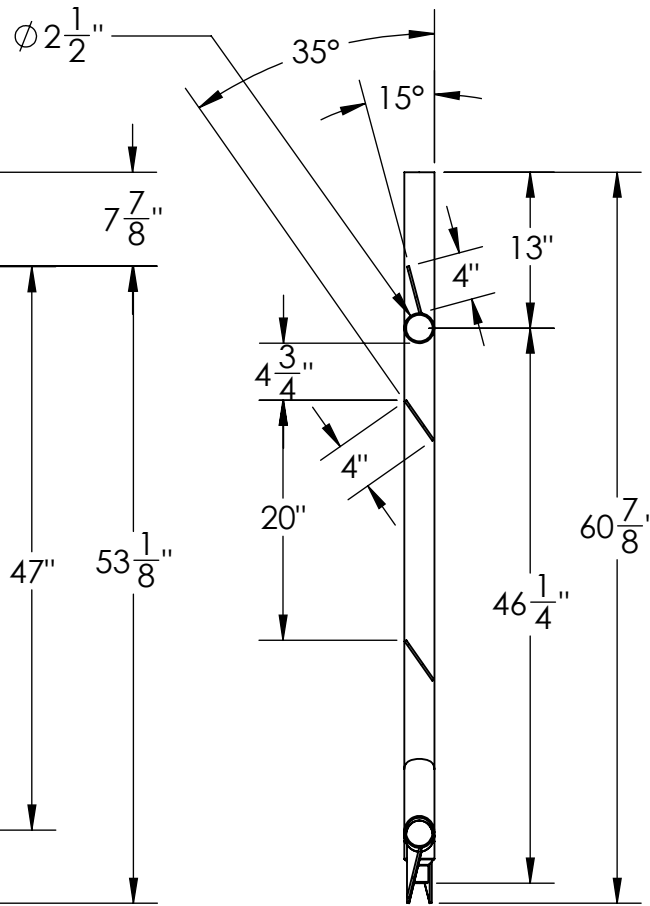
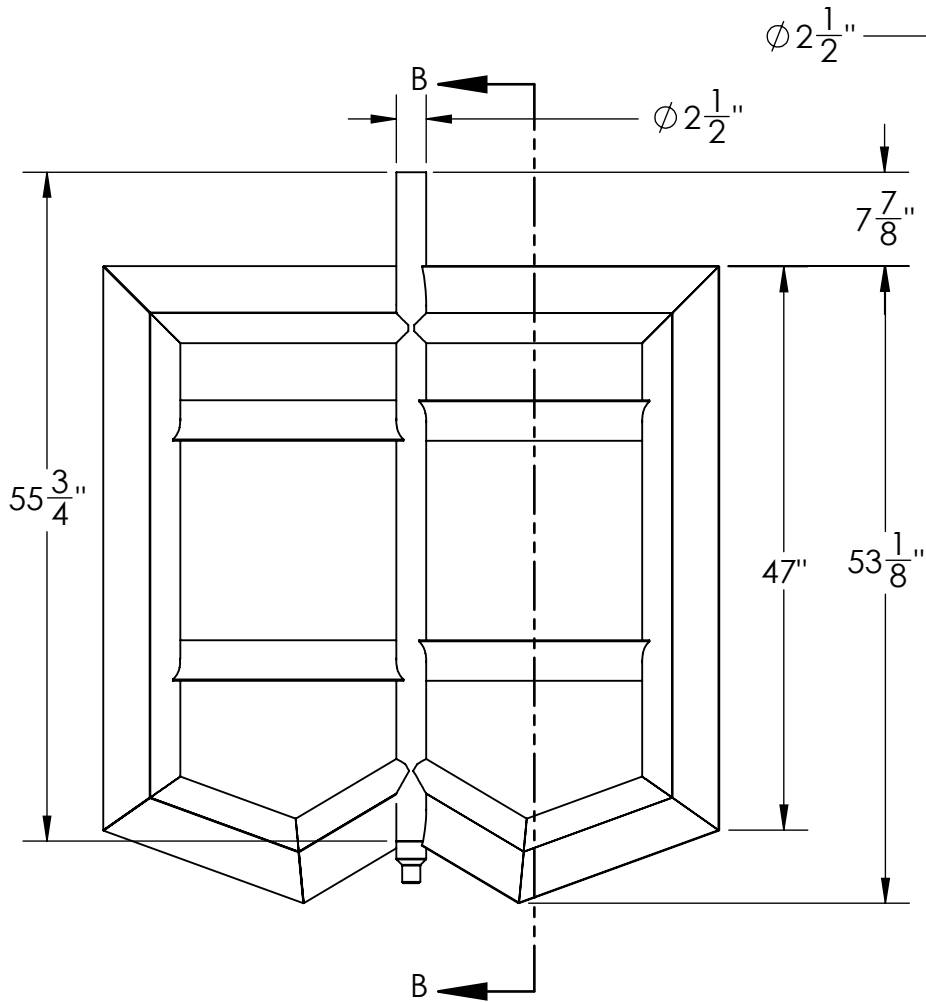
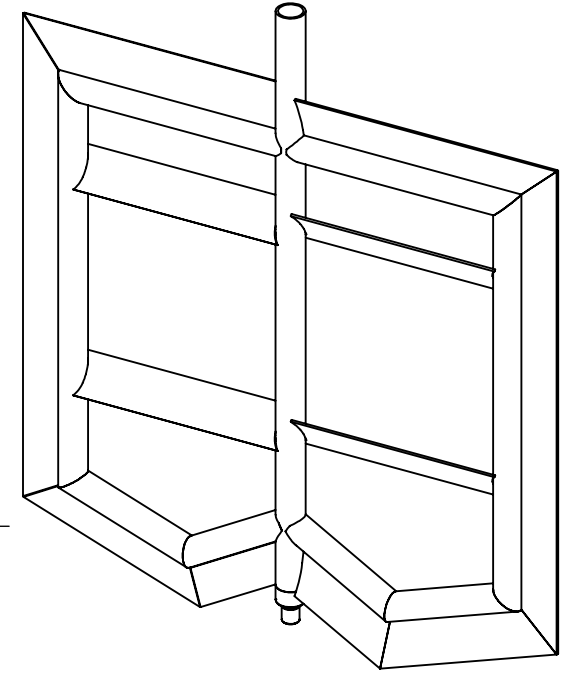
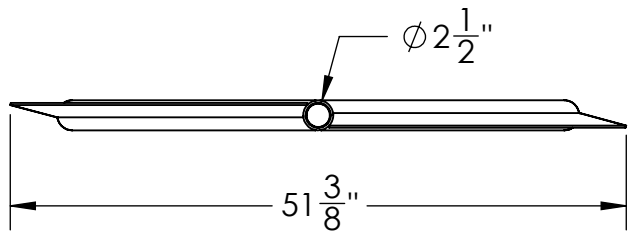

SECTION B-B

[RAD] STAINLESS	JOB NAME: AGITATOR	SALES ORDER / CONTACT: RAD STAINLESS
	TOLERANCE: +/- 1/16" MATERIAL: 304 S.S.	MODEL NUMBER: 48 D. - TANK
	DRAWN BY: O. W. D.	DATE: Monday, July 8, 2019

REVISION: **A**

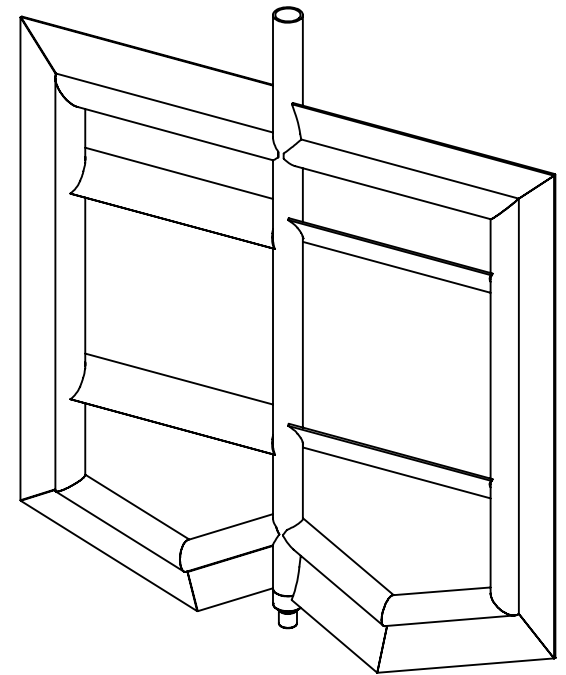
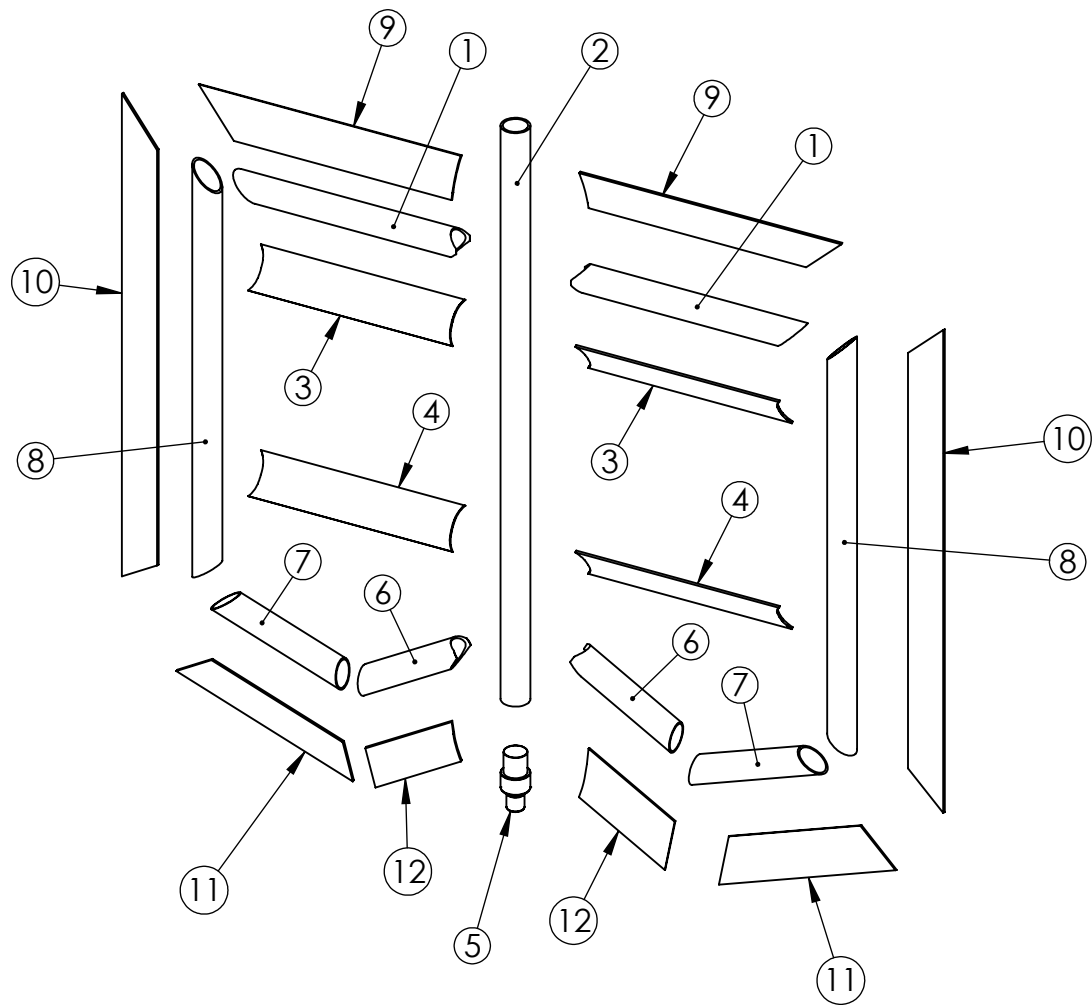

ITEM NO.	QTY.	DESCRIPTION	LENGTH
1	2	PIPE, SCH 40, 2 1/8" DIA.	21 1/2"
2	1	PIPE, SCH 40, 2 1/8" DIA.	55 3/4"
3	2	BLADE 1A 1/8"x4"	19 1/4"
4	2	BLADE 2A 1/8"x4"	19 1/4"
5	1	SPINDLE 2 1/2" DIA.	5 1/2"
6	2	PIPE, SCH 40, 2 1/8" DIA.	11 3/8"
7	2	PIPE, SCH 40, 2 1/8" DIA.	13 1/8"
8	2	PIPE, SCH 40, 2 1/8" DIA.	40 3/8"
9	2	BLADE 3A 1/8"x4"	24 3/4"
10	2	BLADE 4A 1/8"x4"	47"
11	2	BLADE 5A 1/8"x4"	17 3/4"
12	2	BLADE 6A 1/8"x4"	11 1/4"

[RAD]
STAINLESS

JOB NAME: AGITATOR EXPLODED

TOLERANCE: +/- 1/16"

DRAWN BY: O. W. D.

MATERIAL: 304 S.S.

SALES ORDER / CONTACT: RAD STAINLESS

MODEL NUMBER: 48 D. - TANK

DATE: Monday, July 8, 2019

REVISION: **A**