

THE GENERAL CONTRACTOR SHALL CHECK AND VERIFY ALL DIMENSIONS AND REPORT ALL ERRORS AND OMISSIONS TO THE ARCHITECTS. DO NOT SCALE THE DRAWINGS. THIS DRAWING SHALL NOT BE USED FOR CONSTRUCTION PURPOSES UNTIL SIGNED BY THE CONSULTANTS.

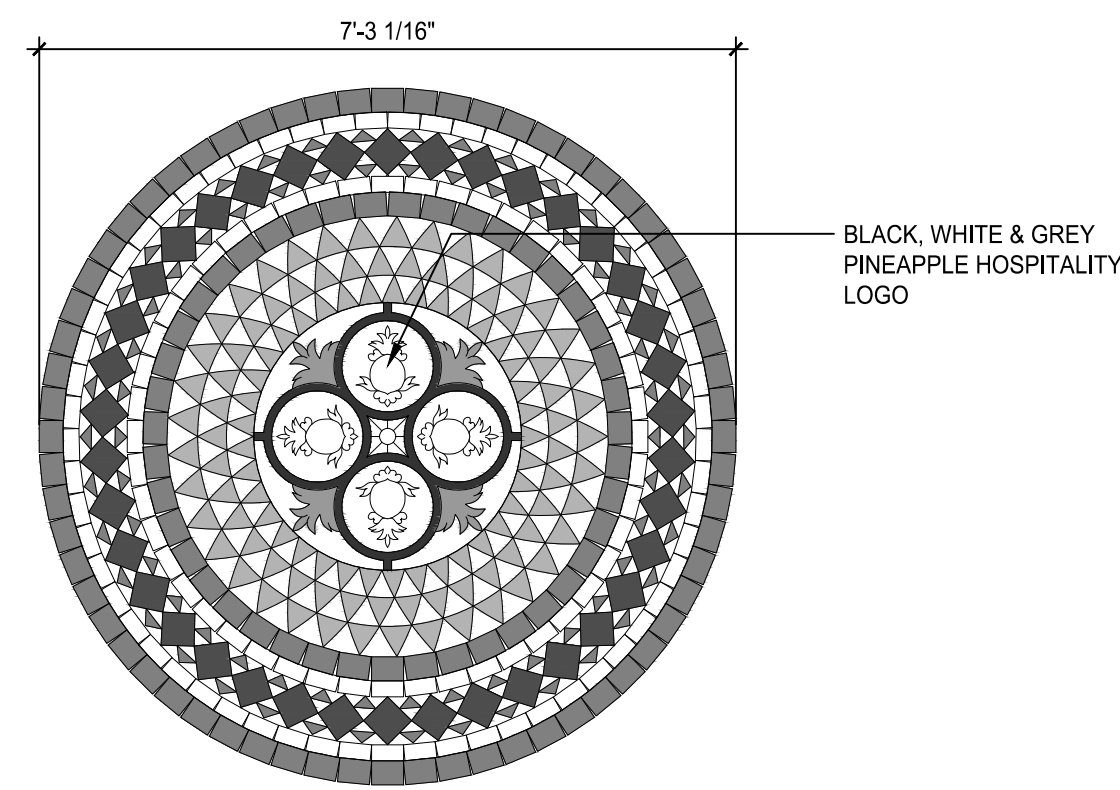

2 TAB: TILE MEDALLION W/ PINEAPPLE LOGO (T-3)
SCALE: 1/2" = 1'-0"

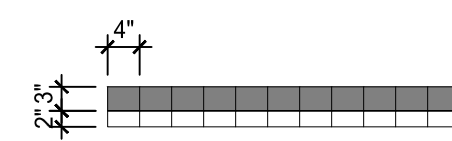

3 TAB: MARBLE BORDER TILE (T-2)
SCALE: 1/2" = 1'-0"

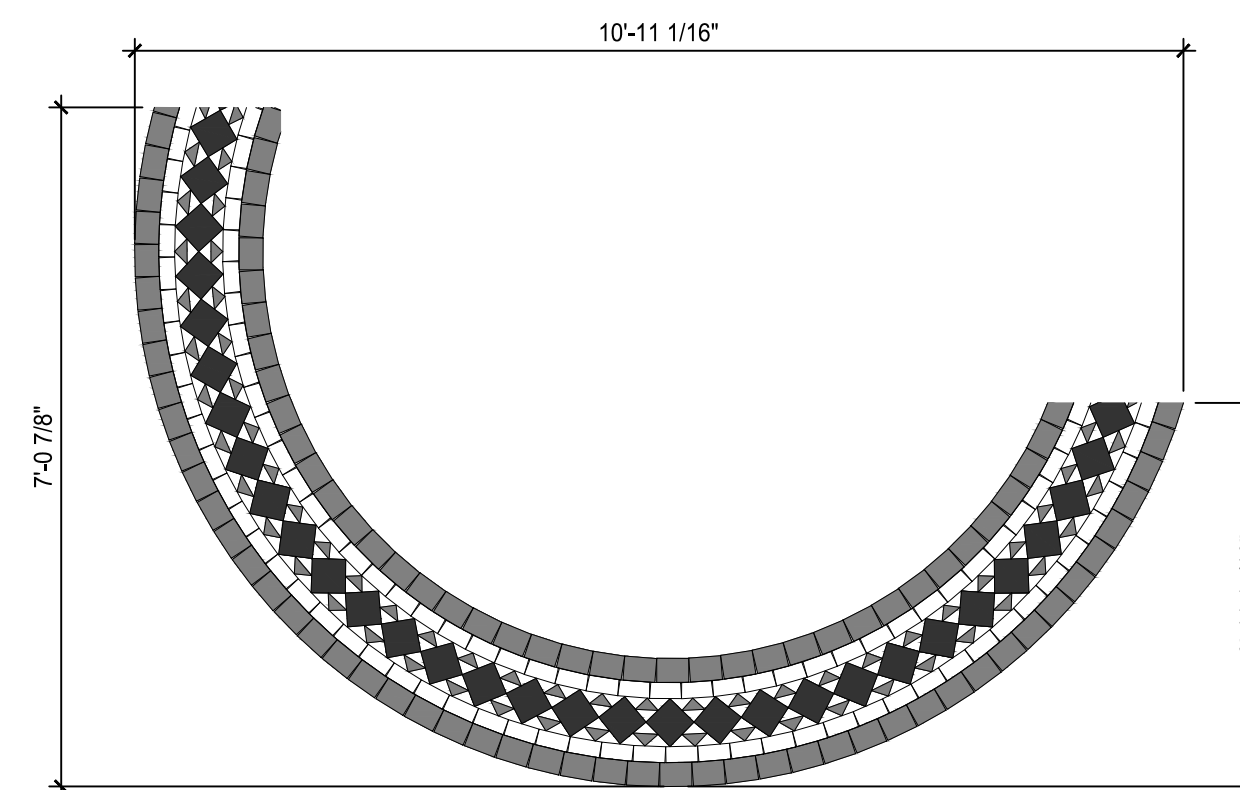

4 TAB: TILE BANDING AT ENTRANCE (T-4)
SCALE: 1/2" = 1'-0"

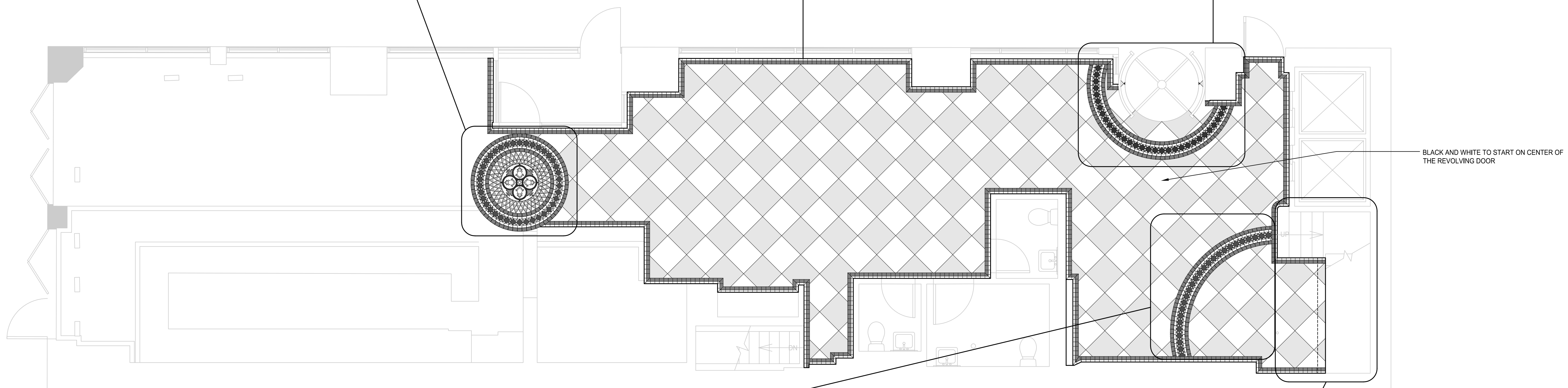

REVISIONS:

#	DATE	DESCRIPTION
01		
02		
03		
04		
05		
06		
07		
08		
09		
10		
11		
12		
13		
14		
15		
16		
17		
18		
19		
20		

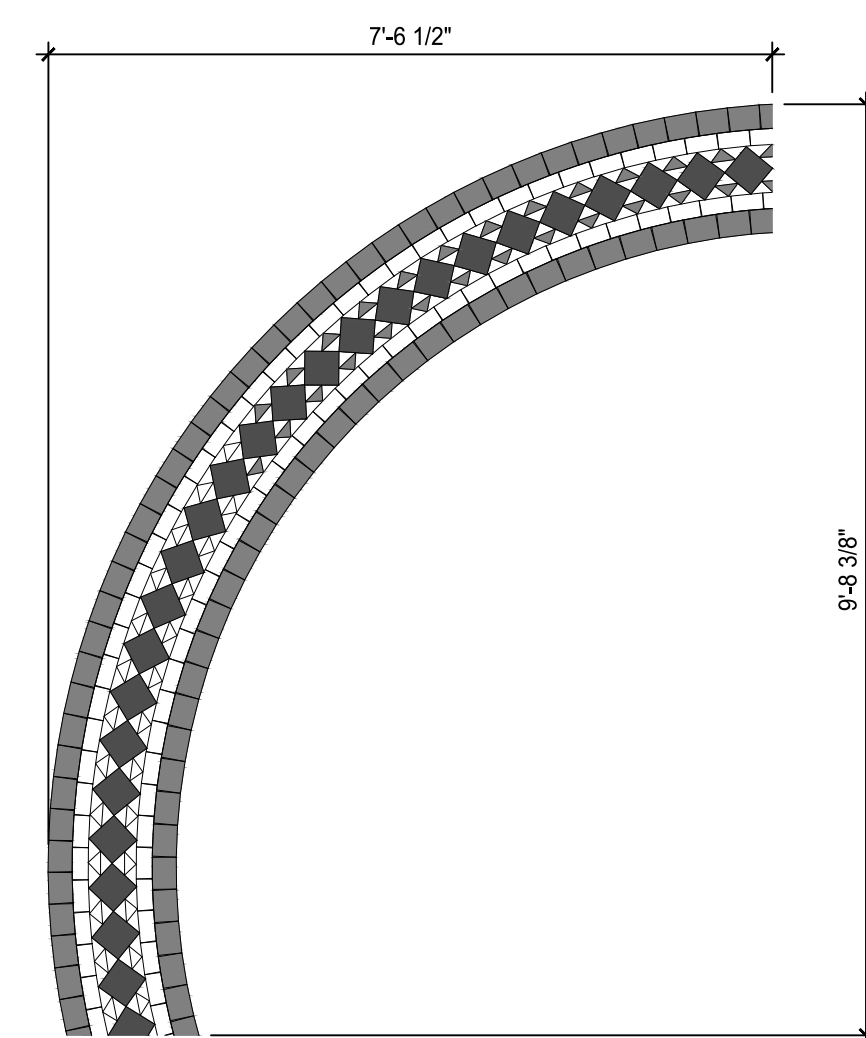

5 TAB: TILE BANDING AT RECEPTION (T-5)
SCALE: 1/2" = 1'-0"

1 THE ALISE BOSTON - TILE FLOOR PATTERN
SCALE: 1/4" = 1'-0"

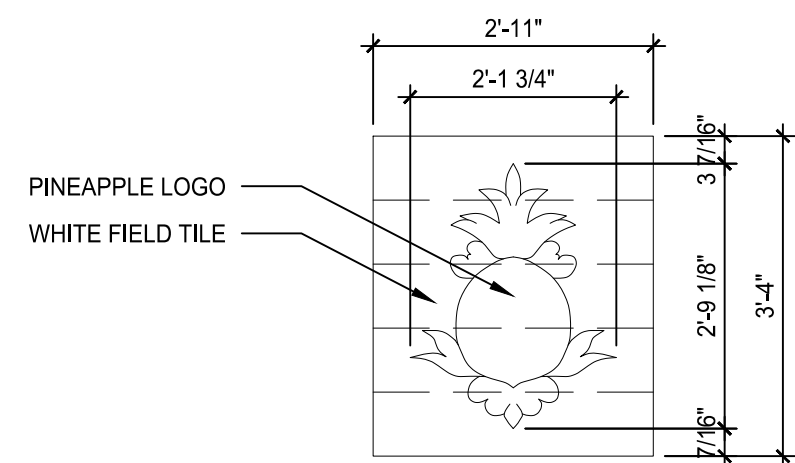

6 TAB: STAIR FACE DESIGN - 1 OF 3
SCALE: 1/2" = 1'-0"

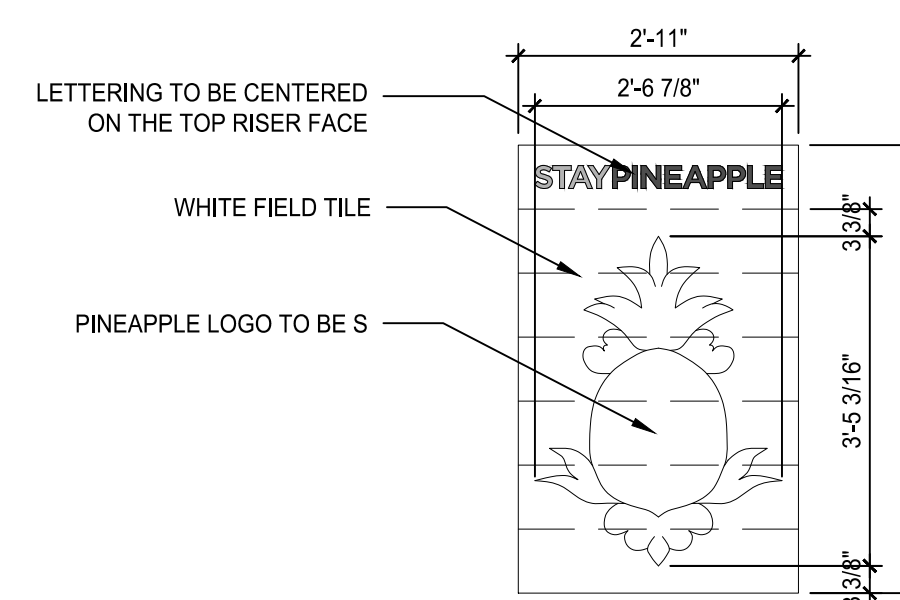

7 TAB: STAIR FACE DESIGN - 2 OF 3
SCALE: 1/2" = 1'-0"

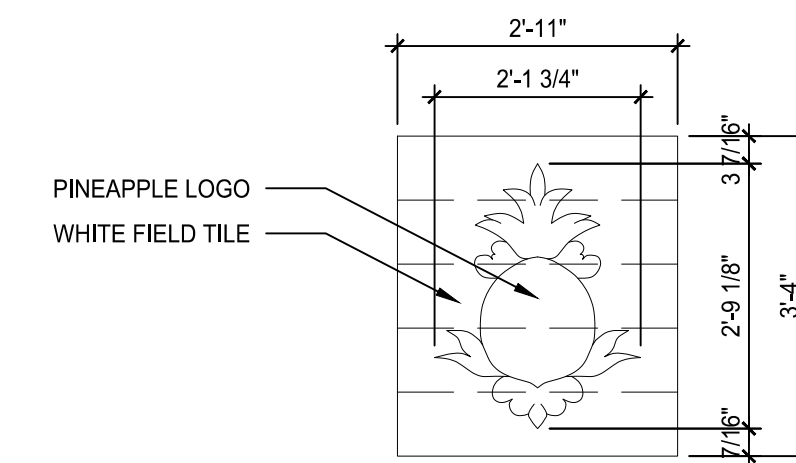

8 TAB: STAIR FACE DESIGN - 3 OF 3
SCALE: 1/2" = 1'-0"



155 108TH AVENUE NE
SUITE 500
BELLEVUE, WA 98004
TEL. 425.974.7148
FAX 425.455.5749

CONTACT:
DINA BELON, DIRECTOR OF REAL ESTATE
407.256.7742

DRAWN BY: PK
CHECKED BY:
DATE: 10/22/2018

PROJECT NAME:
THE ALISE BOSTON
26 CHANDLER STREET
BOSTON, MA 02116

SHEET TITLE:
LOBBY TILE PLAN

SHEET NO:
PH4.02