

8

7

6

5

4

3

2

1

QTY	PART #	MATERIAL	DESCRIPTION
1	CN-ASSY		CONCENTRATOR ASSEMBLY
1	JG-ASSY		JIG ASSEMBLY
1	FN-ASSY		FUNNEL ASSEMBLY
1	CB-ASSY		CONTROL BOX ASSEMBLY
1	PT-ASSY		PLATFORM ASSEMBLY
1	GR-ASSY		GEAR ASSEMBLY
1	FT-ASSY		FRONT TROUGH ASSEMBLY
1	RT-ASSY		REAR TROUGH ASSEMBLY
1	LD-ASSY		LOADER ASSEMBLY

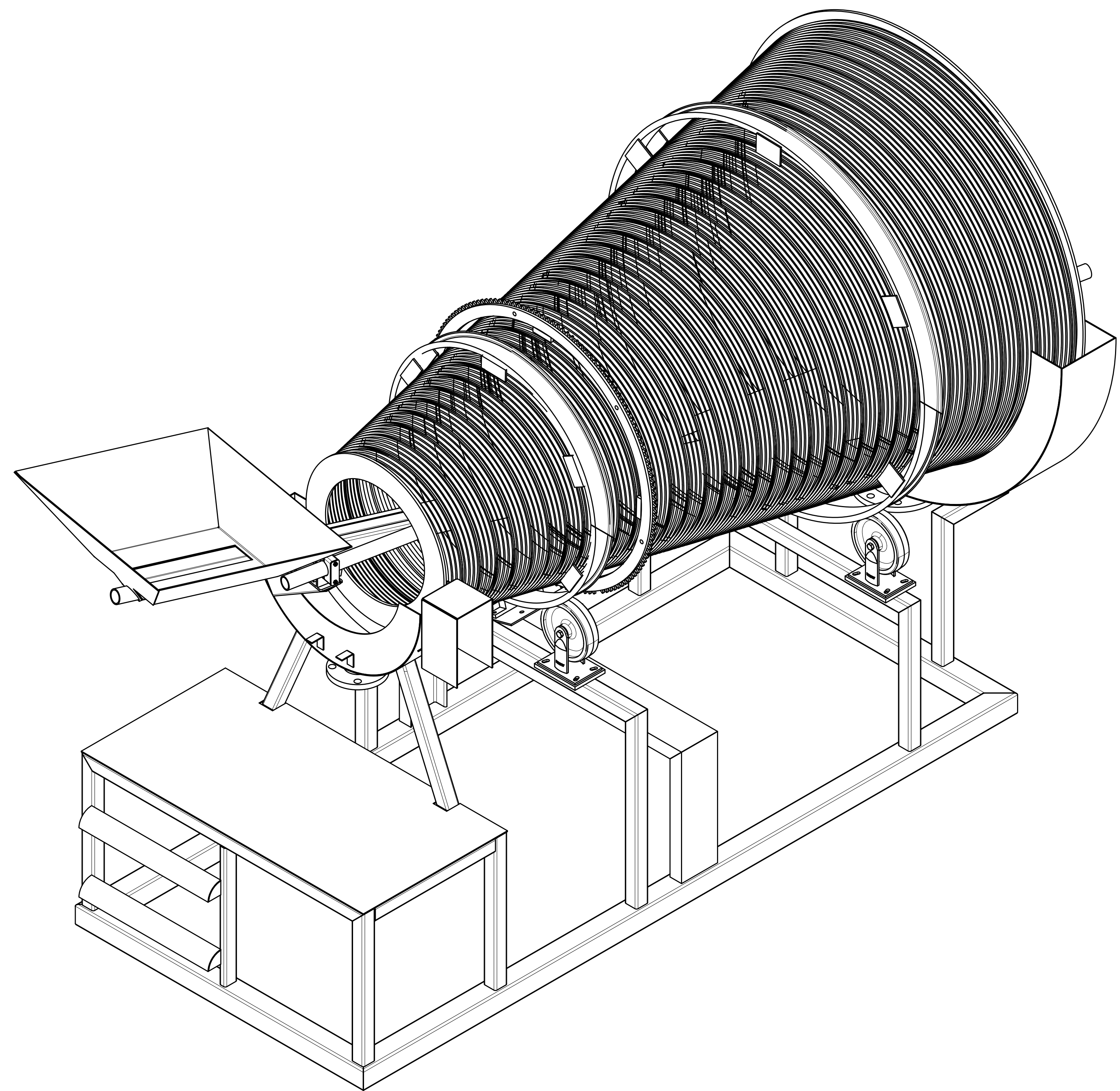

VAZAR INC. 3025 ELDRIDGE AVE BELLINGHAM, WA	DRAWN BY:		TOLERANCES UNLESS NOTED OTHERWISE		ASSY:	NEXT ASSY:	PART NO:	QTY:	SCALE
	CHECKED BY:		FRACTIONS: $\pm 1/16"$	ANGLES: $\pm 30'$	CONCENTRATOR ASSEMBLY			MATERIAL:	SIZE:
	DATE CREATED:		DECIMALS: $\pm 0.10$					DESC:	ANSI
	LAST REVISION:				TITLE	UNIT: DEHAVILLAND	MODEL: DHC-3	SHEET	
MFG BY	REV:								

8

7

6

5

4

3

2

1

H

H

G

G

F

F

E

E

D

D

C

C

B

B

A

A

4

3

2

1

QTY	PART #	MATERIAL	DESCRIPTION
1	TRR-01	11ga Sheet Metal	OUTSIDE TROUGH EDGE
1	TRR-02	11 ga Sheet Metal	TROUGH WALL
1	TRR-03	11ga Sheet Metal	INSIDE TROUGH WALL
2	TRR-04	HSS 2 x 2 x .125	REAR TROUGH SUPPORT ARM
2	TRR-05	HSS 2 x 2 x .125	REAR TROUGH SUPPORT LEG
1	TRR-06	A36 Steel	REAR TROUGH DRAIN
1	TRR-07	11ga Sheet Metal	CHUTE END SUPPORT
1	TRR-08	$\frac{3}{8}$ x 4 Flat Bar	PIPE SUPPORT ARM

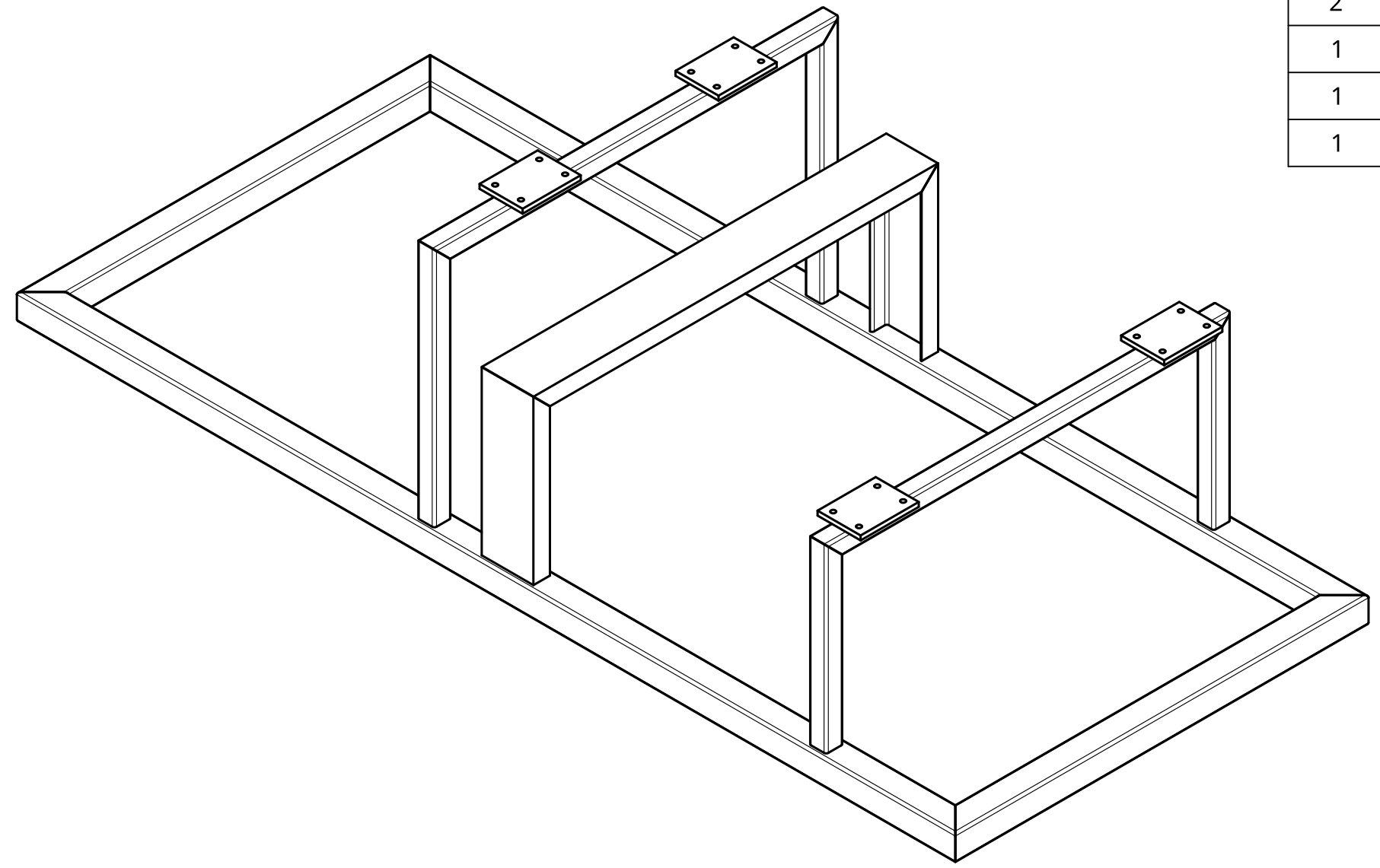

D

D

C

C

B

B

A

A

VAZAR INC. 3025 ELDRIDGE AVE BELLINGHAM, WA	DRAWN BY:	JOSHUA HUPP	TOLERANCES UNLESS NOTED OTHERWISE			ASSY:	JIG	NEXT ASSY:		PART NO:		QTY:		SCALE	1:12
	CHECKED BY:		FRACTIONS:	$\pm 1/16"$	ANGLES:	$\pm 30'$	<i>Jig Assembly</i>			MATERIAL:	A36 Steel		SIZE:	<b>B</b>	
	DATE CREATED:	03/02/2020	DECIMALS:	$\pm 0.10$						DESC:		ANSI			
	LAST REVISION:	05/10/2021	FINISH AS PER FS-2576												
MFG BY	REV:		WELD AS PER AC 43.13-IA STEEL			TITLE			UNIT:	DEHAVILLAND	MODEL:	DHC-3	SHEET	2 OF 23	

4

3

2

1

4

3

2

1

QTY	PART #	MATERIAL	DESCRIPTION
2	BS-01	HSS 3x3x.120 x108-15/16	BASE LENGTH
2	BS-02	HSS 3x3x.120 x47-15/16	BASE WIDTH

D

D

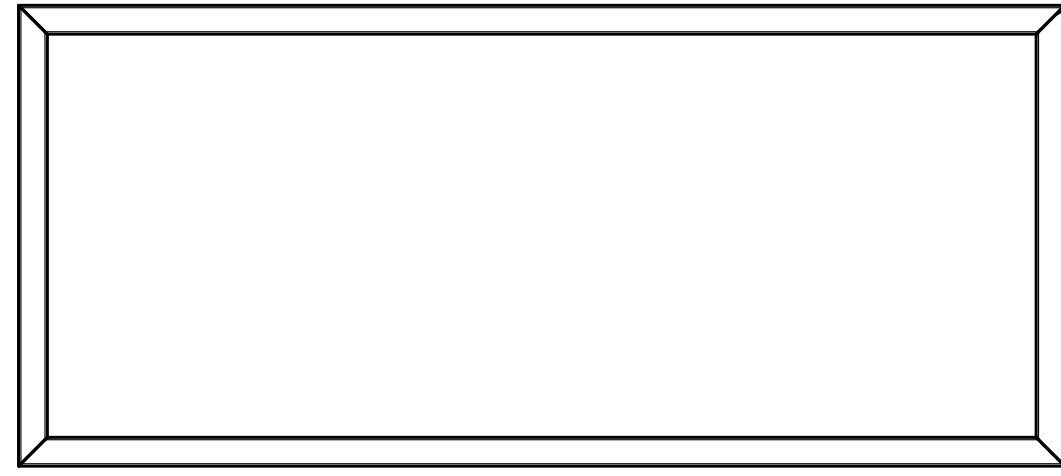

SCALE 1:20

C

C

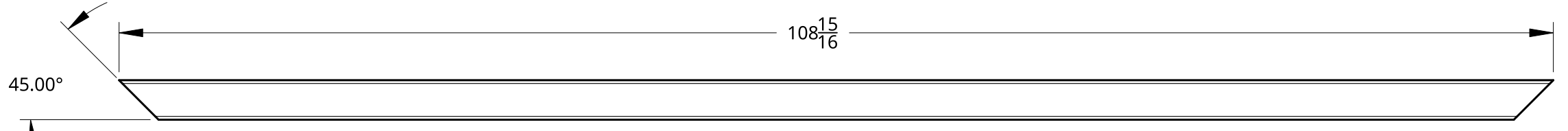
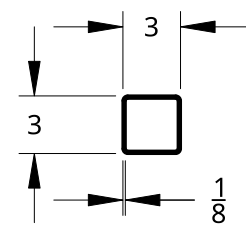

B

B

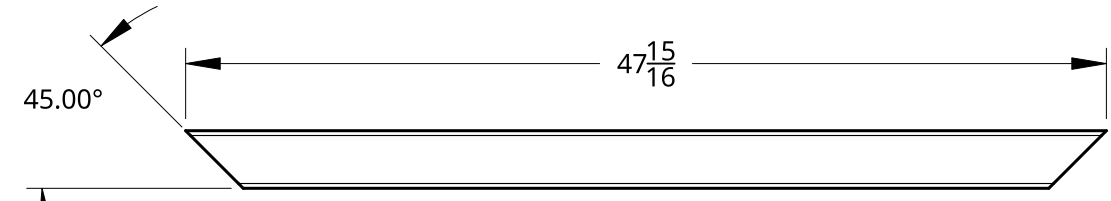
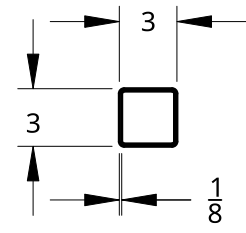

A

A

VAZAR INC. 3025 ELDRIDGE AVE BELLINGHAM, WA	DRAWN BY:	JOSHUA HUPP	TOLERANCES UNLESS NOTED OTHERWISE			ASSY:	BS	NEXT ASSY:		PART NO:		QTY:		SCALE	1:10
	CHECKED BY:		FRACTIONS:	± 1/16"	ANGLES:	± 30'	<i>Jig Base</i>			MATERIAL:	A36 Steel		SIZE:	B	
	DATE CREATED:	03/02/2020	DECIMALS:	± 0.10	FINISH AS PER FS-2576					DESC:			ANSI		
	LAST REVISION:	05/10/2021	WELD AS PER AC 43.13-IA STEEL			TITLE			UNIT:	DEHAVILLAND	MODEL:	DHC-3	SHEET	3 OF 23	

4

3

2

1

4

3

2

1

QTY	PART #	MATERIAL	DESCRIPTION
2	CS-01	HSS 2x2x.120 x28	FRONT CASTER SUPPORT LEG
2	CS-02	HSS 2x2x.120 x20 <sup>3</sup> / <sub>4</sub>	REAR CASTER SUPPORT LEG
2	CS-03	HSS 2x2x.120 x46 <sup>15</sup> / <sub>16</sub>	CASTER SUPPORT CONNECTOR
4	CS-04	PL 1/2x5x6 <sup>3</sup> / <sub>4</sub>	CASTER SUPPORT PLATE

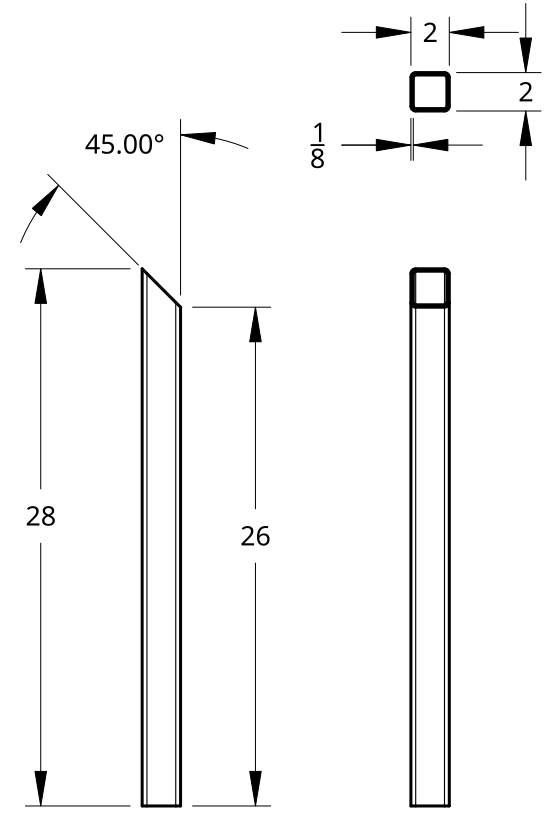

CS-01 - Front Caster Support Leg

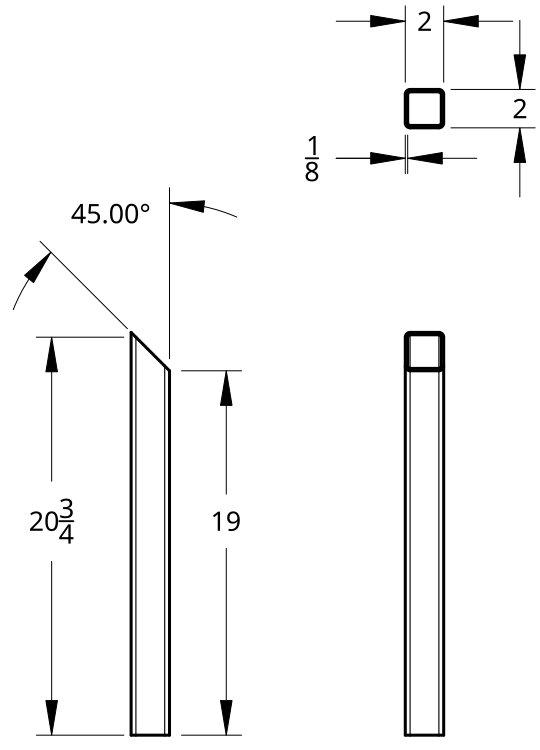

CS-02 - Rear Caster Support Leg

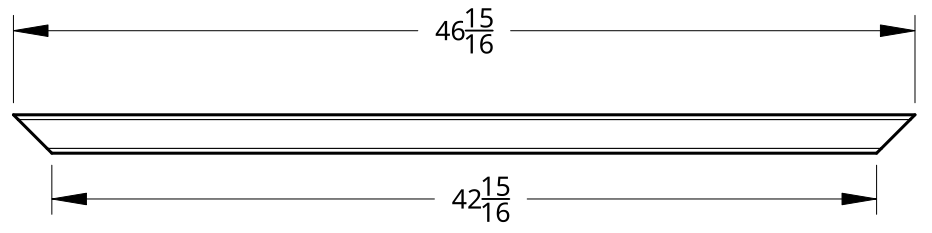

CS-04 - Caster Support Plate

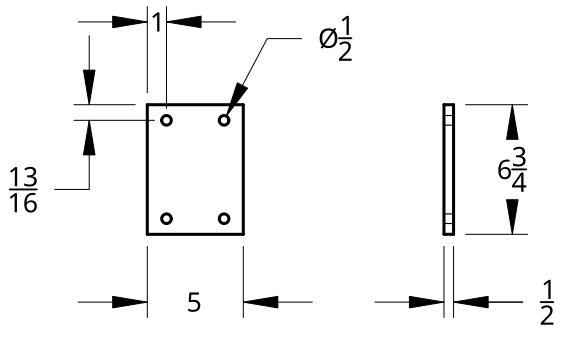

CS-03 - Caster Support Connector

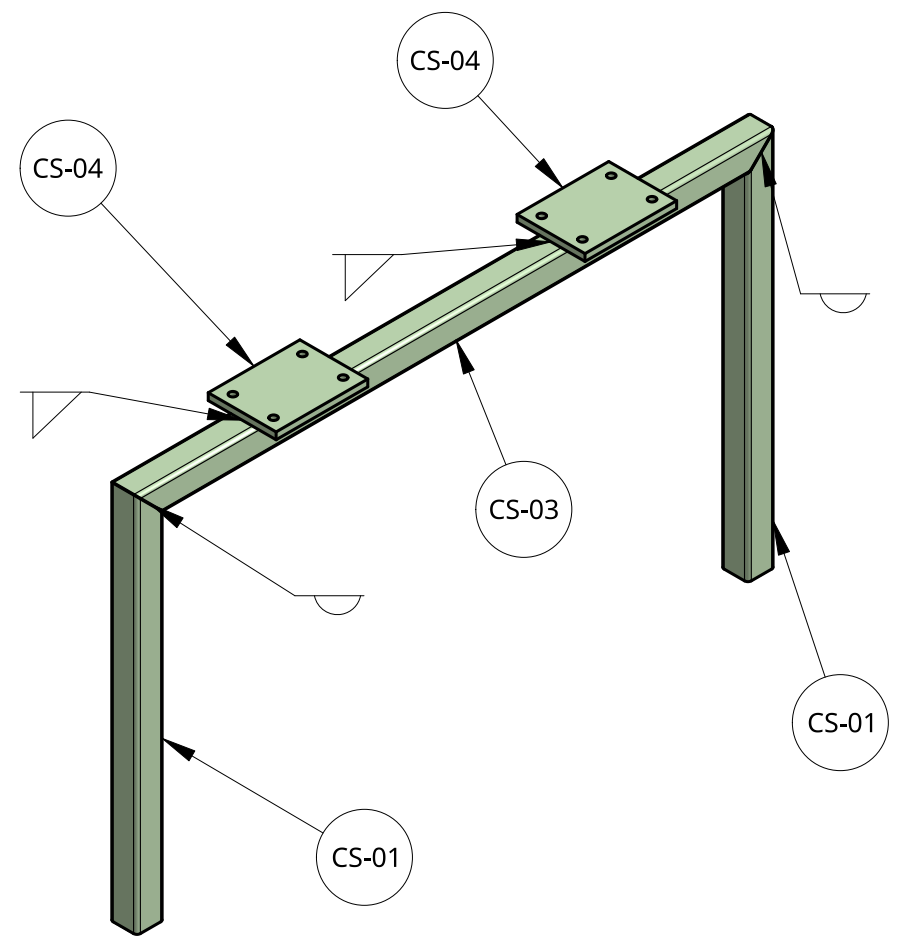

D

D

C

C

B

B

A

A

VAZAR INC. 3025 ELDRIDGE AVE BELLINGHAM, WA	DRAWN BY:	JOSHUA HUPP	TOLERANCES UNLESS NOTED OTHERWISE		ASSY:	CS	NEXT ASSY:		PART NO:		QTY:		SCALE	1:10
	CHECKED BY:		FRACTIONS:	± 1/16"	ANGLES:	± 30'	CASTER SUPPORT			MATERIAL:		A36	SIZE:	B
	DATE CREATED:	03/02/2020	DECIMALS:	± 0.10	FINISH AS PER FS-2576					DESC:		ANSI		
	LAST REVISION:	05/10/2021	WELD AS PER AC 43.13-IA STEEL		TITLE					UNIT:	DEHAVILLAND	MODEL:	DHC-3	SHEET
MFG BY	REV:													

4

3

2

1

4

3

2

1

QTY	PART #	MATERIAL	DESCRIPTION
2	CS-01	HSS 2x2x.120 x28	FRONT CASTER SUPPORT LEG
2	CS-02	HSS 2x2x.120 x20 <sup>3</sup> / <sub>4</sub>	REAR CASTER SUPPORT LEG
2	CS-03	HSS 2x2x.120 x46 <sup>15</sup> / <sub>16</sub>	CASTER SUPPORT CONNECTOR
4	CS-04	PL 1/2x5x6 <sup>3</sup> / <sub>4</sub>	CASTER SUPPORT PLATE

D

D

C

C

B

B

A

A

<b>VAZAR INC.</b> 3025 ELDRIDGE AVE BELLINGHAM, WA	DRAWN BY:	JOSHUA HUPP	TOLERANCES UNLESS NOTED OTHERWISE			ASSY:		NEXT ASSY:		PART NO:		QTY:		SCALE	<b>B</b>
	CHECKED BY:		FRACTIONS:	± 1/16"	ANGLES:	± 30'				MATERIAL:		SIZE:			
	DATE CREATED:	03/02/2020	DECIMALS:	± 0.10							ANSI				
	LAST REVISION:	05/10/2021	FINISH AS PER FS-2576												
MFG BY	REV:		WELD AS PER AC 43.13-IA STEEL			TITLE			UNIT:	DEHAVILLAND	MODEL:	DHC-3	SHEET	5 OF 23	

4

3

2

1

4

3

2

1

QTY	PART #	MATERIAL	DESCRIPTION
2	PL-01	HSS 2 x 2 x .125	PLATFORM BRIDGE
4	PL-02	HSS 2 x 2 x .125	PLATFORM LEG
2	PL-03	HSS 2 x 2 x .125	PLATFORM CONNECTOR
3	PL-04	HSS 2 x 2 x .125	PLATFORM SUPPORT
4	PL-05	1/4 Plate	PLATFORM STEP FLANGE
2	PL-06	Expanded Metal	PLATFORM STEP COVER
1	PL-07	Expanded Metal	PLATFORM TOP

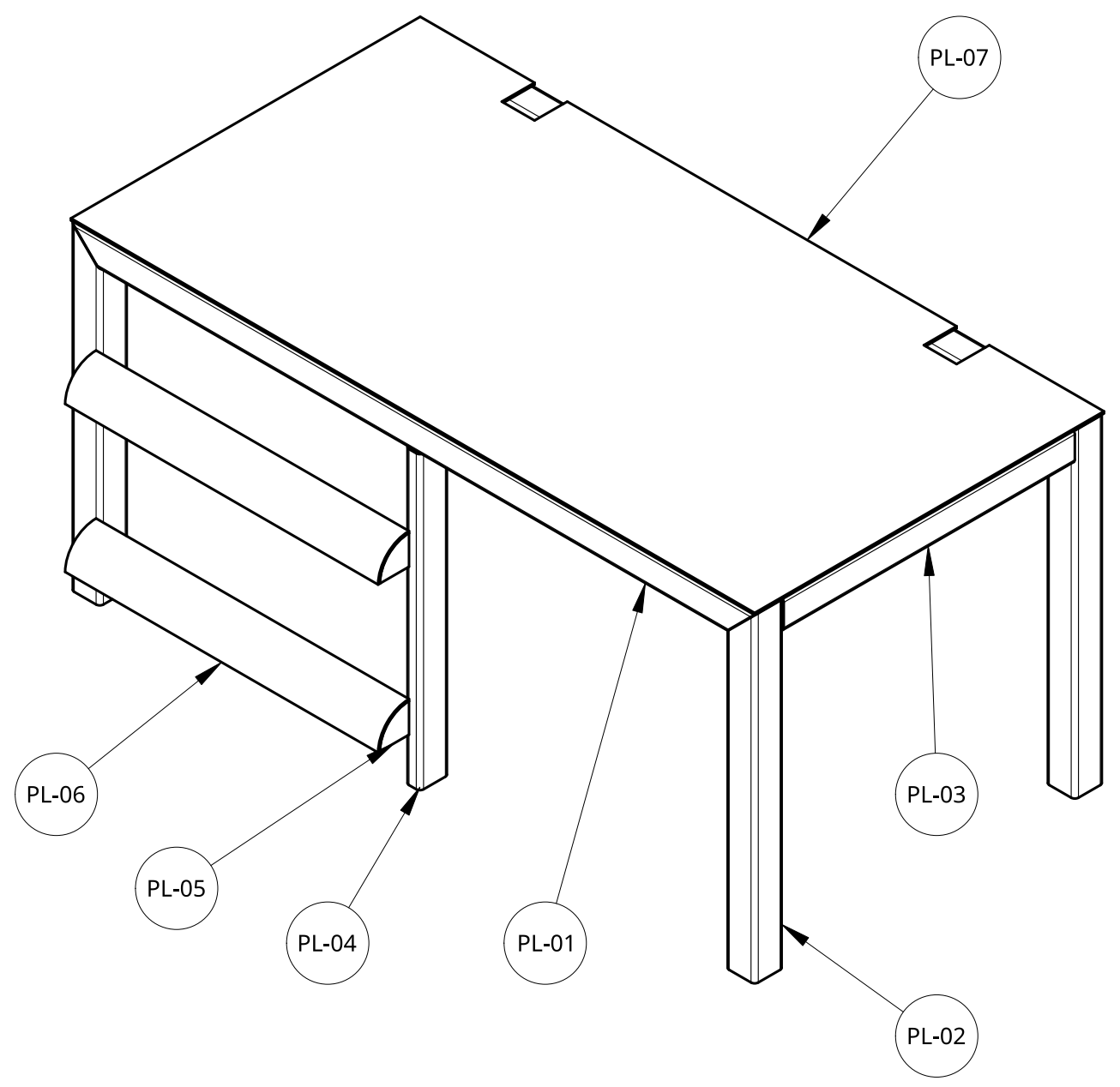

D

D

C

C

B

B

A

A

VAZAR INC. 3025 ELDRIDGE AVE BELLINGHAM, WA	DRAWN BY:	JOSHUA HUPP	TOLERANCES UNLESS NOTED OTHERWISE			ASSY:	PL	NEXT ASSY:		PART NO:		QTY:		SCALE	1:8
	CHECKED BY:		FRACTIONS:	± 1/16"	ANGLES:	± 30'	PLATFORM ASSEMBLY			MATERIAL:	A36 Steel		SIZE:	B	
	DATE CREATED:	03/02/2020	DECIMALS:	± 0.10						DESC:		ANSI			
	LAST REVISION:	05/10/2021	FINISH AS PER FS-2576												
MFG BY	REV:		WELD AS PER AC 43.13-IA STEEL			TITLE			UNIT:	DEHAVILLAND	MODEL:	DHC-3	SHEET	6 OF 23	

4

3

2

1

4

3

2

1

QTY	PART #	MATERIAL	DESCRIPTION
2	PL-01	HSS 2x2x.125x46- <sup>15</sup> / <sub>16</sub>	PLATFORM SUPPORT BRIDGE
4	PL-02	HSS 2x2x.125x22	PLATFORM LEG
2	PL-03	HSS 2x2x.125x20	PLATFORM CONNECTOR
2	PL-04	HSS 2x1x.125x20	PLATFORM SUPPORT

D

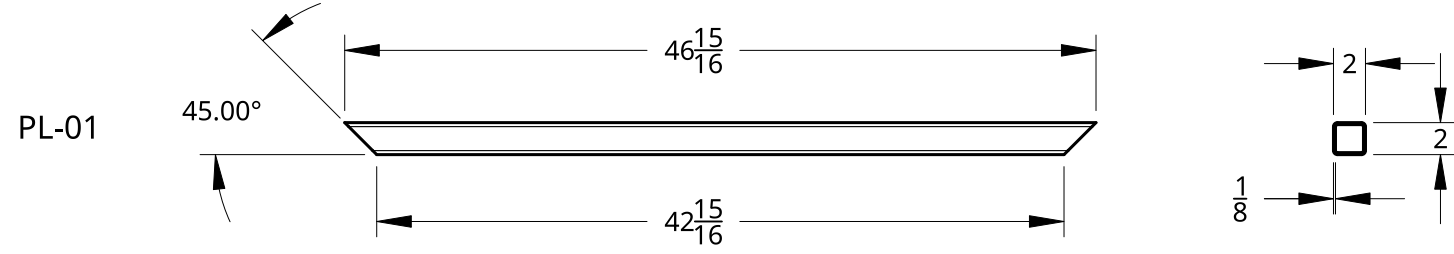

D

C

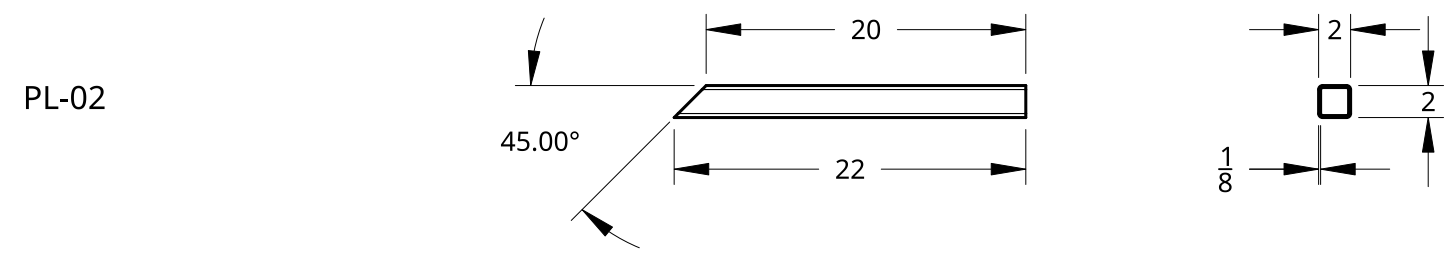

C

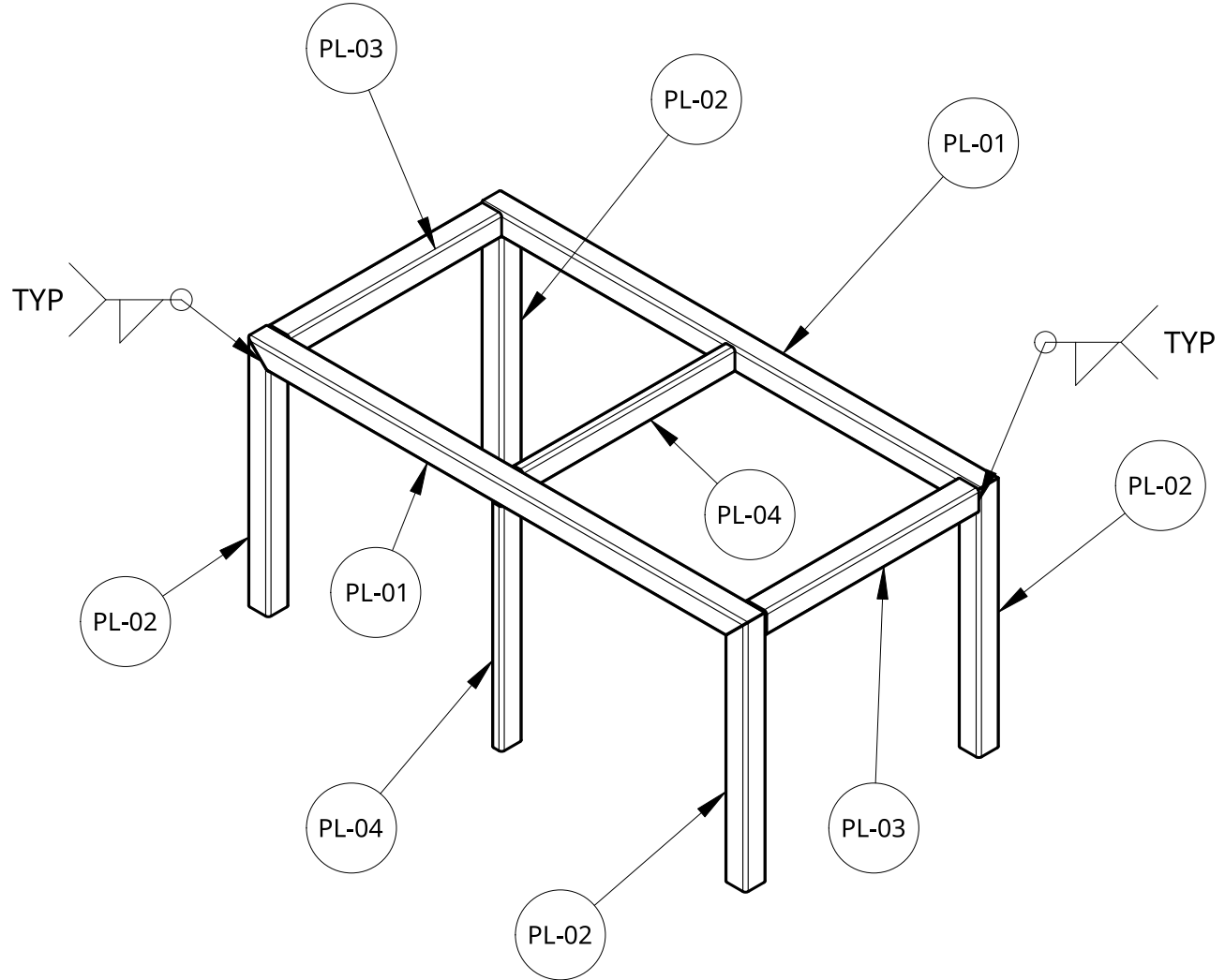
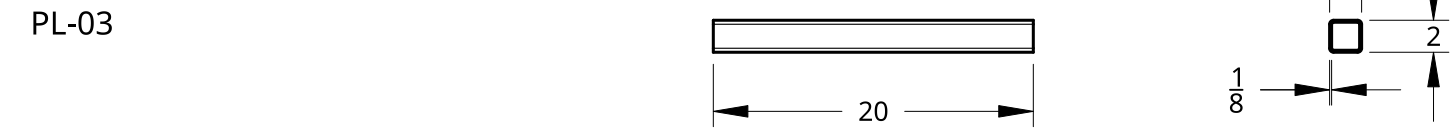

B

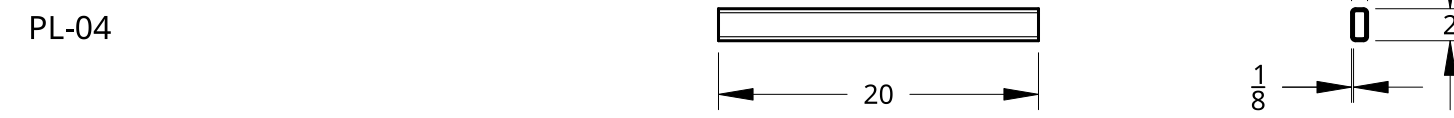

B

A

VAZAR INC. 3025 ELDRIDGE AVE BELLINGHAM, WA	DRAWN BY:	JOSHUA HUPP	TOLERANCES UNLESS NOTED OTHERWISE		ASSY:	PL	NEXT ASSY:		PART NO:		QTY:		SCALE	1:12
	CHECKED BY:		FRACTIONS:	± 1/16"	ANGLES:	± 30'	PLATFORM ASSY			MATERIAL:	HSS		SIZE:	B
	DATE CREATED:	03/02/2020	DECIMALS:	± 0.10							STEEL ASTM A36		ANSI	
	LAST REVISION:	05/10/2021	FINISH AS PER FS-2576								DESC:			
MFG BY	REV:		WELD AS PER AC 43.13-IA STEEL		TITLE			UNIT:	DEHAVILLAND	MODEL:	DHC-3	SHEET	7 OF 23	

A

4

3

2

1

4

3

2

1

QTY	PART #	MATERIAL	DESCRIPTION
4	PL-05	1/4 Plate	PLATFORM STEP FLANGE
2	PL-06	Expanded Metal 1 5/8 x 4 7/8	PLATFORM STEP COVER
1	PL-07	Expanded Metal 1 5/8 x 4 7/8	PLATFORM TOP

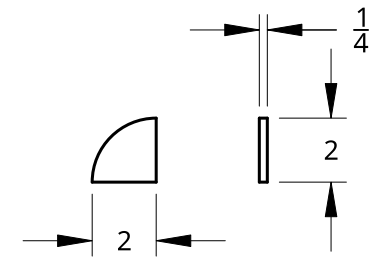

PL-05 - PLATFORM STEP FLANGE

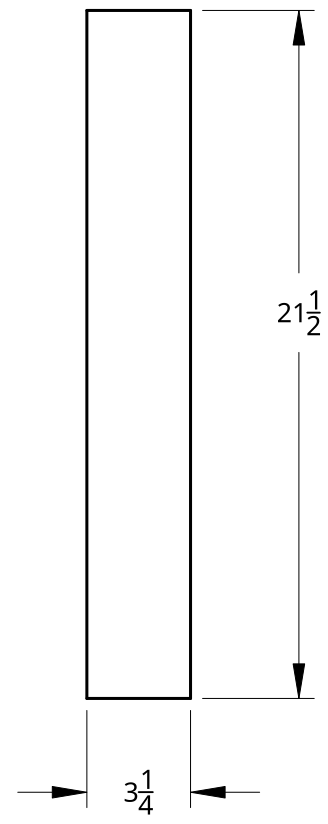

PL-06 - Platform Step  
(Rolled and spot welded to Step Flange)

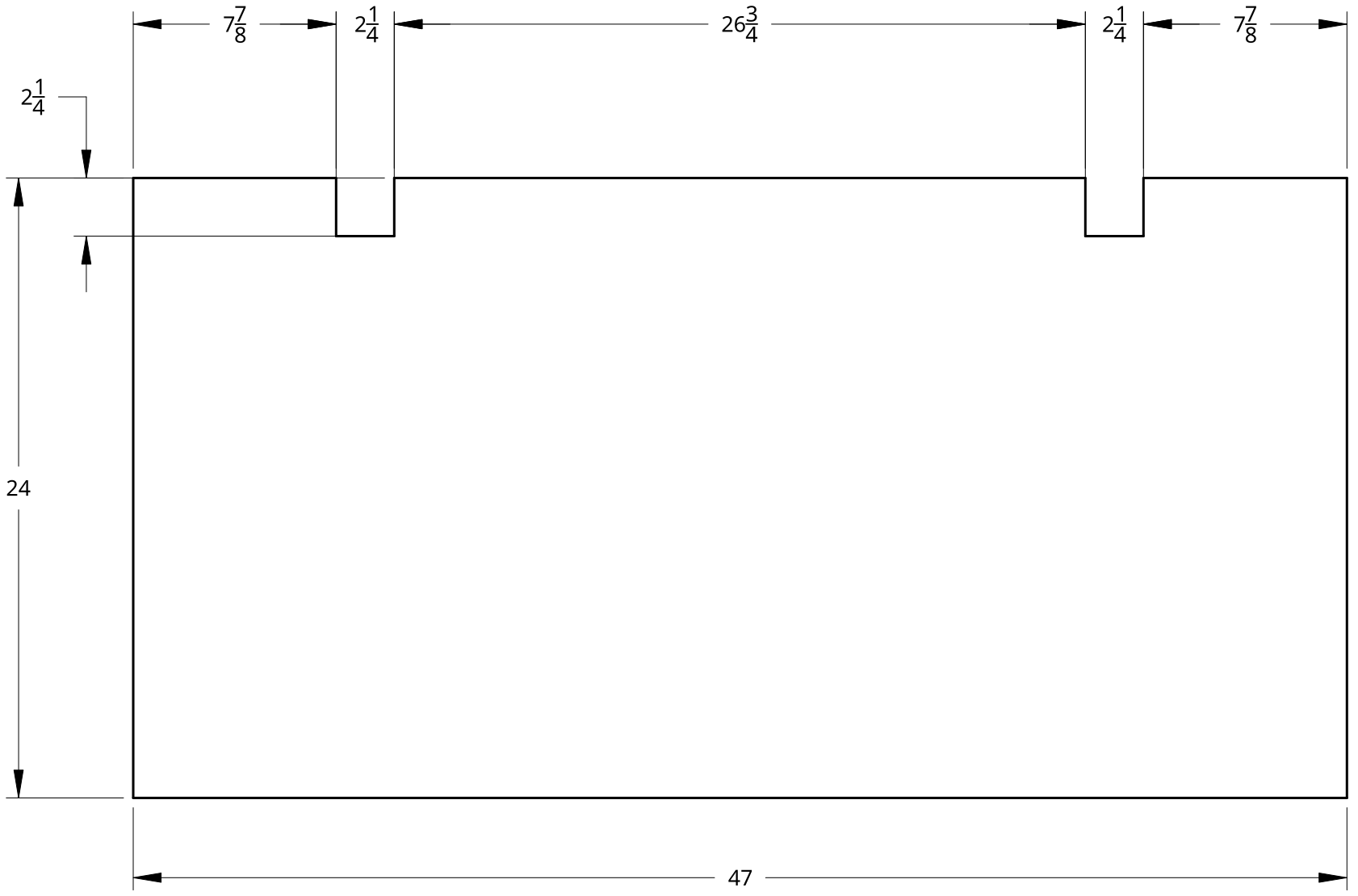

PL-07 - Platform Top

D

D

C

C

B

B

A

A

VAZAR INC. 3025 ELDRIDGE AVE BELLINGHAM, WA	DRAWN BY:	JOSHUA HUPP	TOLERANCES UNLESS NOTED OTHERWISE			ASSY:	PL	NEXT ASSY:		PART NO:		QTY:		SCALE	1:6
	CHECKED BY:		FRACTIONS:	± 1/16"	ANGLES:	± 30'	EXPANDED METAL PLATFORMS			MATERIAL:	Expanded Metal 1-5/8 x 4-7/8		SIZE:	B	
	DATE CREATED:	03/02/2020	DECIMALS:	± 0.10						DESC:	EXPANDED METAL		ANSI		
	LAST REVISION:	05/10/2021	FINISH AS PER FS-2576							UNIT:	DEHAVILLAND	MODEL:	DHC-3	SHEET	8 OF 23
MFG BY	REV:		WELD AS PER AC 43.13-IA STEEL			TITLE									

4

3

2

1



4

3

2

1

QTY	PART #	MATERIAL	DESCRIPTION
31	FN-01	Aluminum Extrusion @12ft	FUNNEL
1	FN-02	$\frac{3}{8}$ x Aluminum Flat Bar	REAR FUNNEL CAP
1	FN-03	$\frac{3}{8}$ Aluminum Plate	FRONT FUNNEL CAP
1	FN-04	1/8 x 3 Aluminum Channel	REAR WHEEL CHANNEL
1	FN-05	1/8 x 3 Aluminum Channel	FRONT WHEEL CHANNEL
1	FN-06	1/4 A36 Steel	CHAIN GEAR
1	FN-07	$\frac{3}{8}$ Aluminum Flat Bar	CHAIN GEAR SUPPORT
28	FN-08	Aluminum Flat Bar	SUPPORT FLANGE

D

D

C

C

B

B

A

A

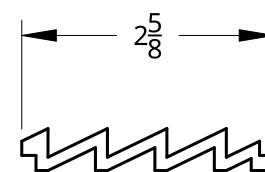
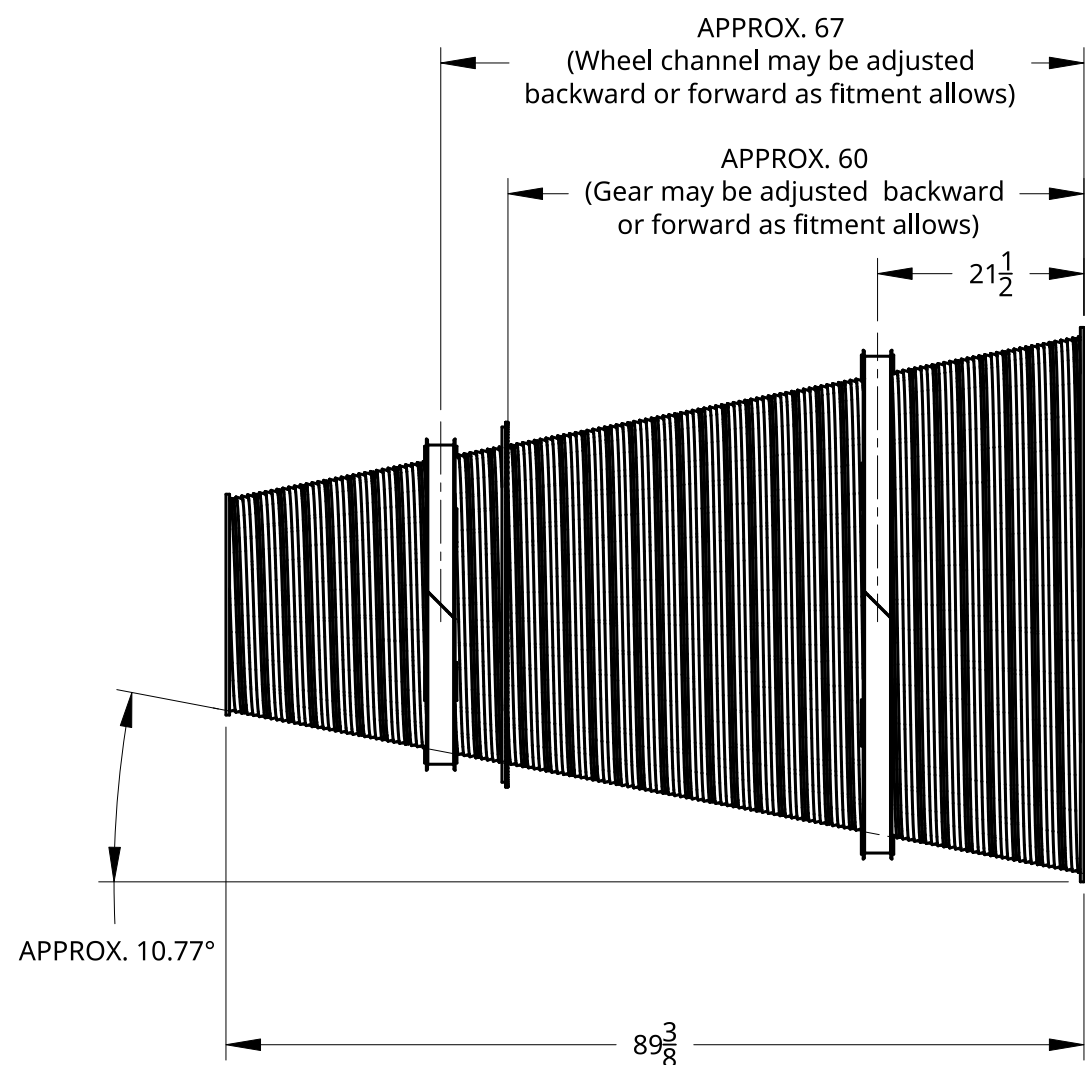

SCALE 1:2

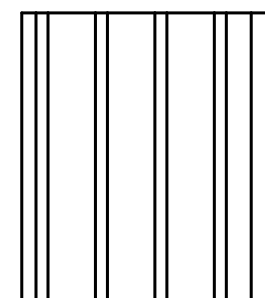

SCALE 1:2

Aluminum Extrusion  
Roll @ approximately 10.75  
degrees and a pitch of  
~2-7/16 in

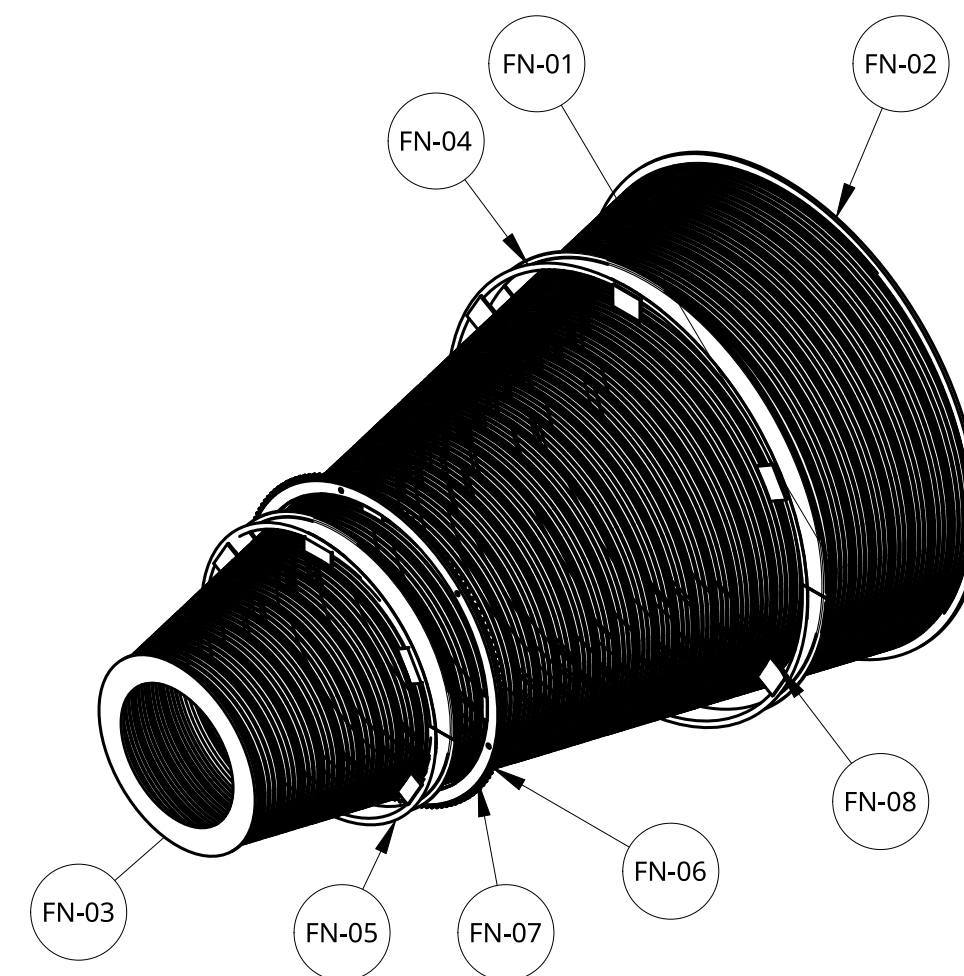

VAZAR INC. 3025 ELDRIDGE AVE BELLINGHAM, WA	DRAWN BY:	JOSHUA HUPP	TOLERANCES UNLESS NOTED OTHERWISE		ASSY:	FN	NEXT ASSY:	TRF	PART NO:	FN-ASSY	QTY:	1	SCALE	1:20
	CHECKED BY:		FRACTIONS:	± 1/16"	ANGLES:	± 30'	FUNNEL ASSEMBLY					SIZE:	B	
	DATE CREATED:	03/02/2020	DECIMALS:	± 0.10						MATERIAL:				ANSI
	LAST REVISION:	05/10/2021	FINISH AS PER FS-2576			DESC:						SHEET		9 OF 23
MFG BY	REV:	WELD AS PER AC 43.13-IA STEEL		TITLE			UNIT:	DEHAVILLAND	MODEL:	DHC-3				

4

3

2

1

4

3

2

1

QTY	PART #	MATERIAL	DESCRIPTION
2	FN-02	ALUM x 6 x 120	REAR FUNNEL END CAP
1	FN-03	ALUM Plate	FRONT FUNNEL END CAP

D

D

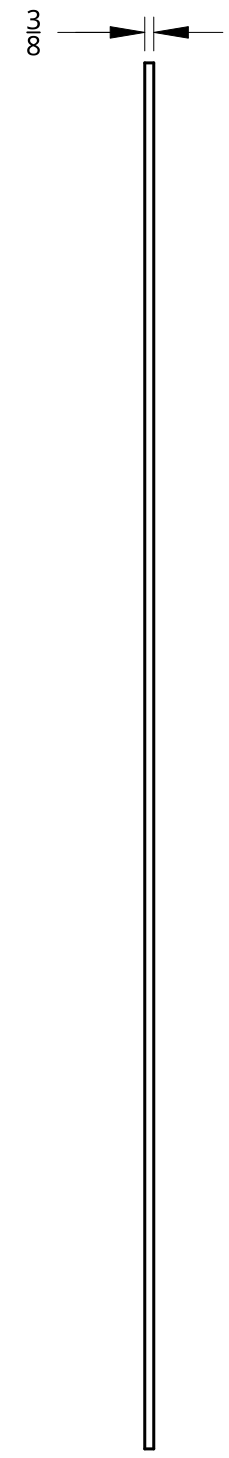
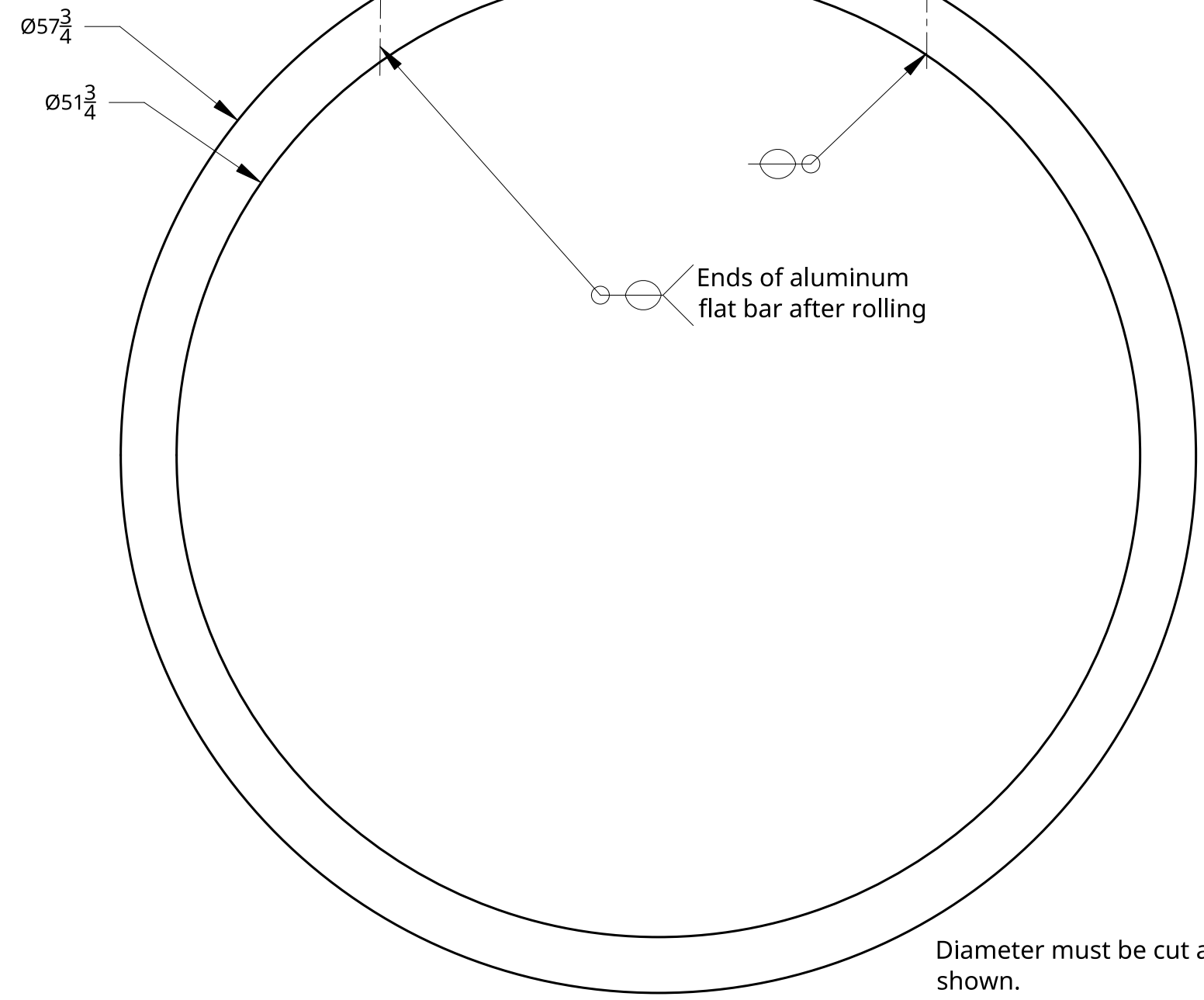

C

C

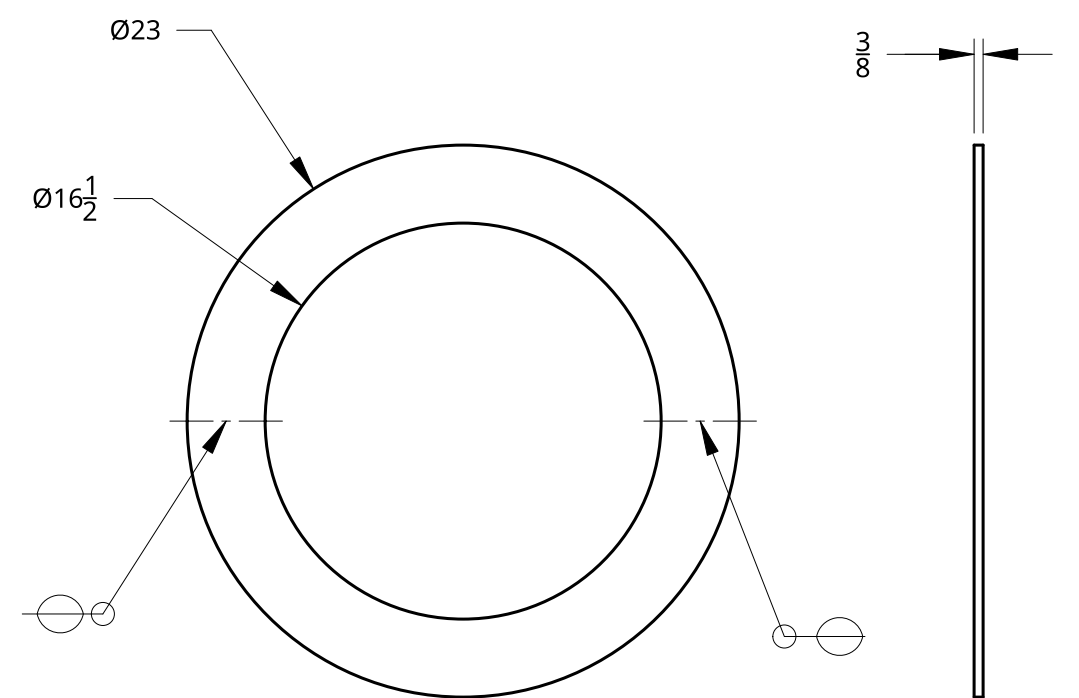

B

B

A

A

VAZAR INC. 3025 ELDRIDGE AVE BELLINGHAM, WA	DRAWN BY:	JOSHUA HUPP	TOLERANCES UNLESS NOTED OTHERWISE			ASSY:	FN	NEXT ASSY:		PART NO:	FN-02 & FN-03	QTY:		SCALE	1:8
	CHECKED BY:		FRACTIONS:	$\pm 1/16"$	ANGLES:	$\pm 30'$	<i>FUNNEL END CAPS</i>			MATERIAL:	ALUMINUM - 1060		SIZE:	<b>B</b>	
	DATE CREATED:	03/02/2020	DECIMALS:	$\pm 0.10$	FINISH AS PER FS-2576					DESC:			ANSI		
	LAST REVISION:	05/10/2021	WELD AS PER AC 43.13-IA STEEL			TITLE				UNIT:	DEHAVILLAND	MODEL:	DHC-3	SHEET	10 OF 23
MFG BY	REV:														

4

3

2

1

4

3

2

1

D

D

C

C

B

B

A

A

QTY	PART #	MATERIAL	DESCRIPTION
1	FN-04	ALUM Channel 3/4 x 3 x 161.75"	REAR WHEEL CHANNEL
1	FN-05	ALUM Channel 3/4 x 3 x 103.75"	FRONT WHEEL CHANNEL
24	FN-08	ALUM Flat Bar $\frac{3}{16}$ x 4 x varies	SUPPORT FLANGES

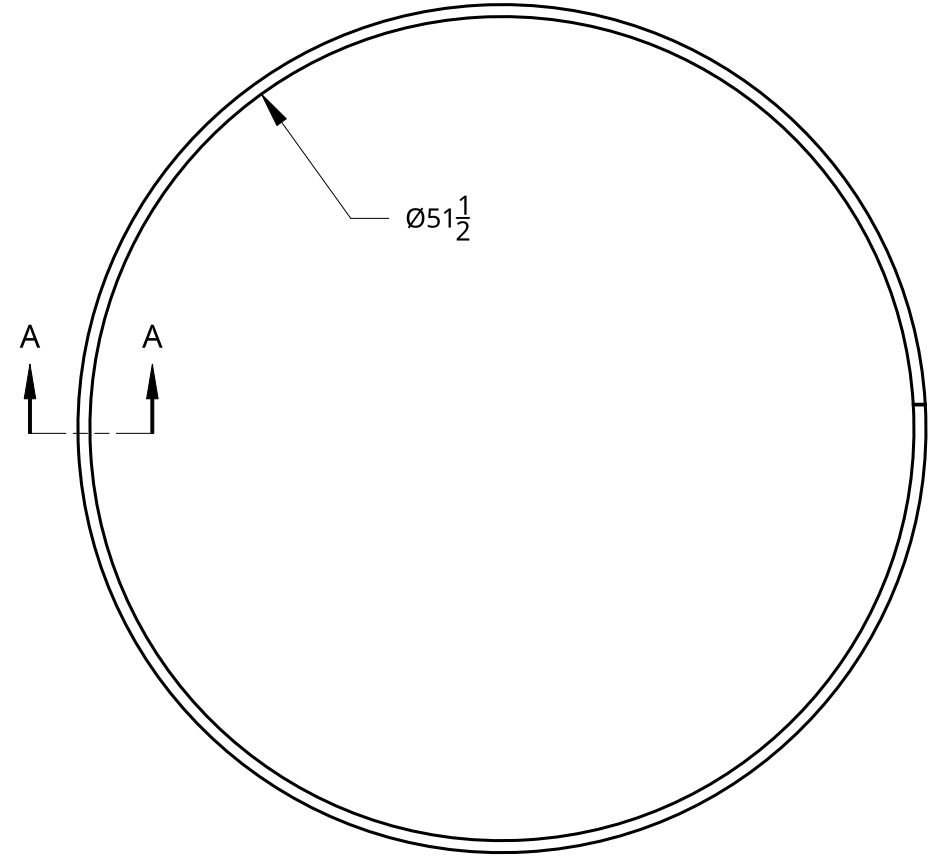

FN-04

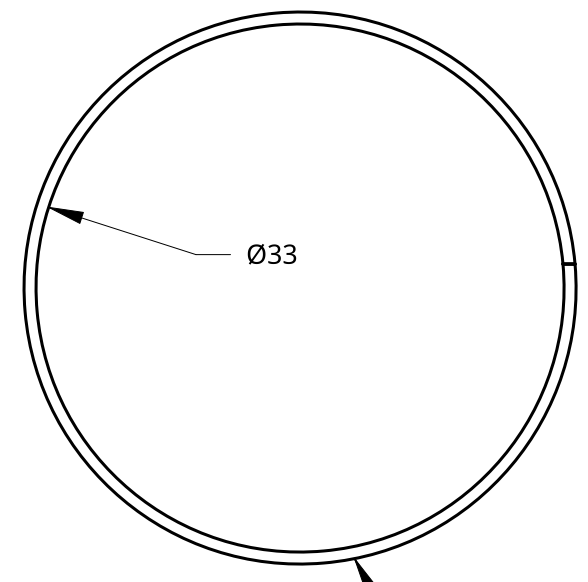
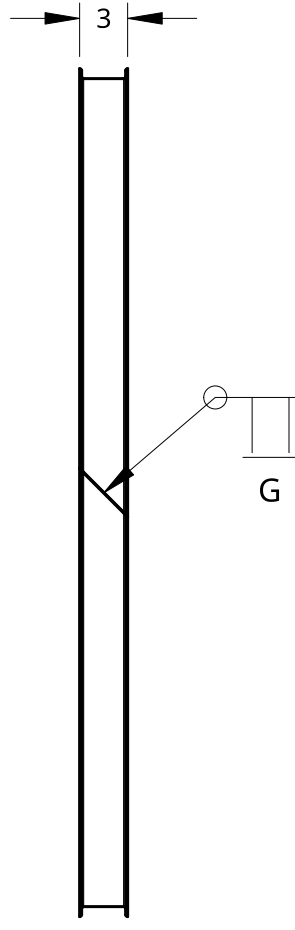

FN-05

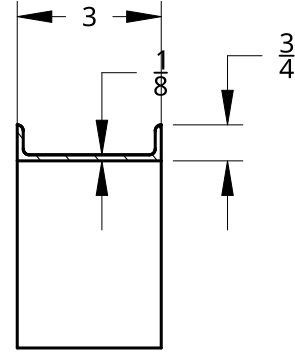
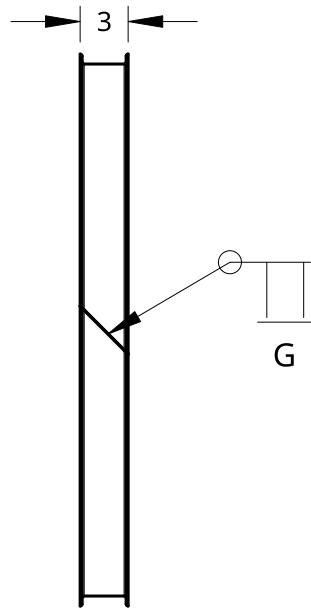

SECTION A - A  
SCALE 1:4

Weld (6) 3/16" plates to each side of channel and weld to funnel. Size will vary due to distance between channel and funnel.

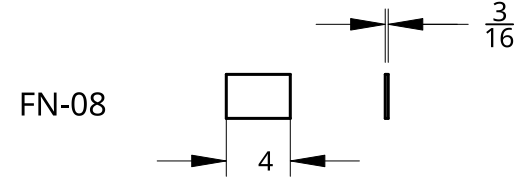

FN-08

<b>VAZAR INC.</b> 3025 ELDRIDGE AVE BELLINGHAM, WA	DRAWN BY:	JOSHUA HUPP	TOLERANCES UNLESS NOTED OTHERWISE			ASSY:	FN	NEXT ASSY:		PART NO:	FN-04 & FN-05	QTY:		SCALE	1:12
	CHECKED BY:		FRACTIONS:	± 1/16"	ANGLES:	± 30'	<i>FUNNEL WHEEL CHANNELS</i>			MATERIAL:	ALUMINUM - 1060		SIZE:	<b>B</b>	
	DATE CREATED:	03/02/2020	DECIMALS:	± 0.10	FINISH AS PER FS-2576					DESC:			ANSI		
	LAST REVISION:	05/10/2021	WELD AS PER AC 43.13-IA STEEL			TITLE				UNIT:	DEHAVILLAND	MODEL:	DHC-3	SHEET	11 OF 23
MFG BY	REV:														

4

3

2

1

4

3

2

1

QTY	PART #	MATERIAL	DESCRIPTION
1	FN-06	A36 Steel Gear 38"Ø	CHAIN GEAR
1	FN-07	ALUM Flat Bar $\frac{3}{8}$ x $1\frac{1}{2}$ x 112"	CHAIN GEAR SUPPORT
6	FN-08	ALUM $\frac{3}{8}$ x 3 x varies Shims	SUPPORT FLANGE

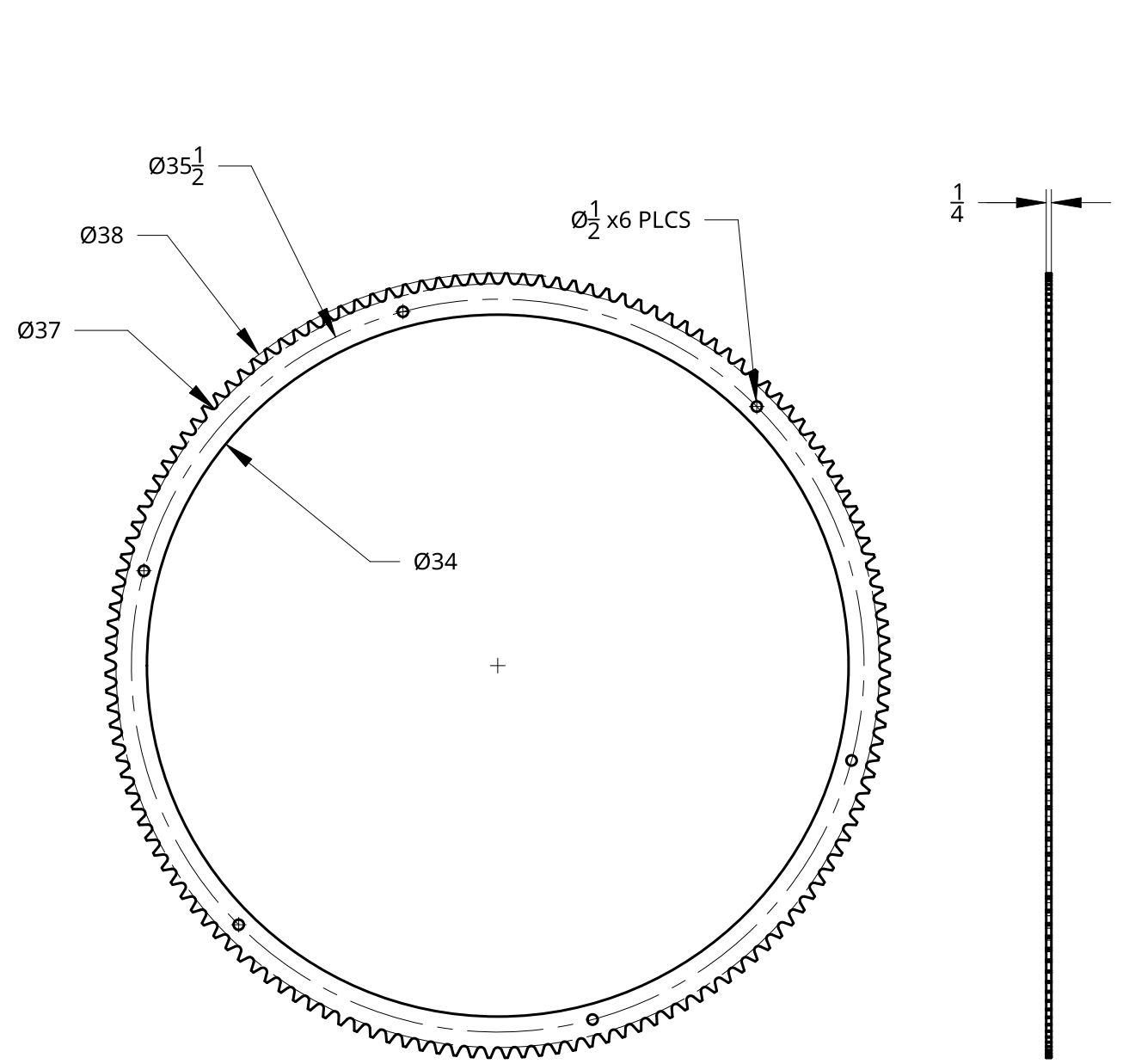
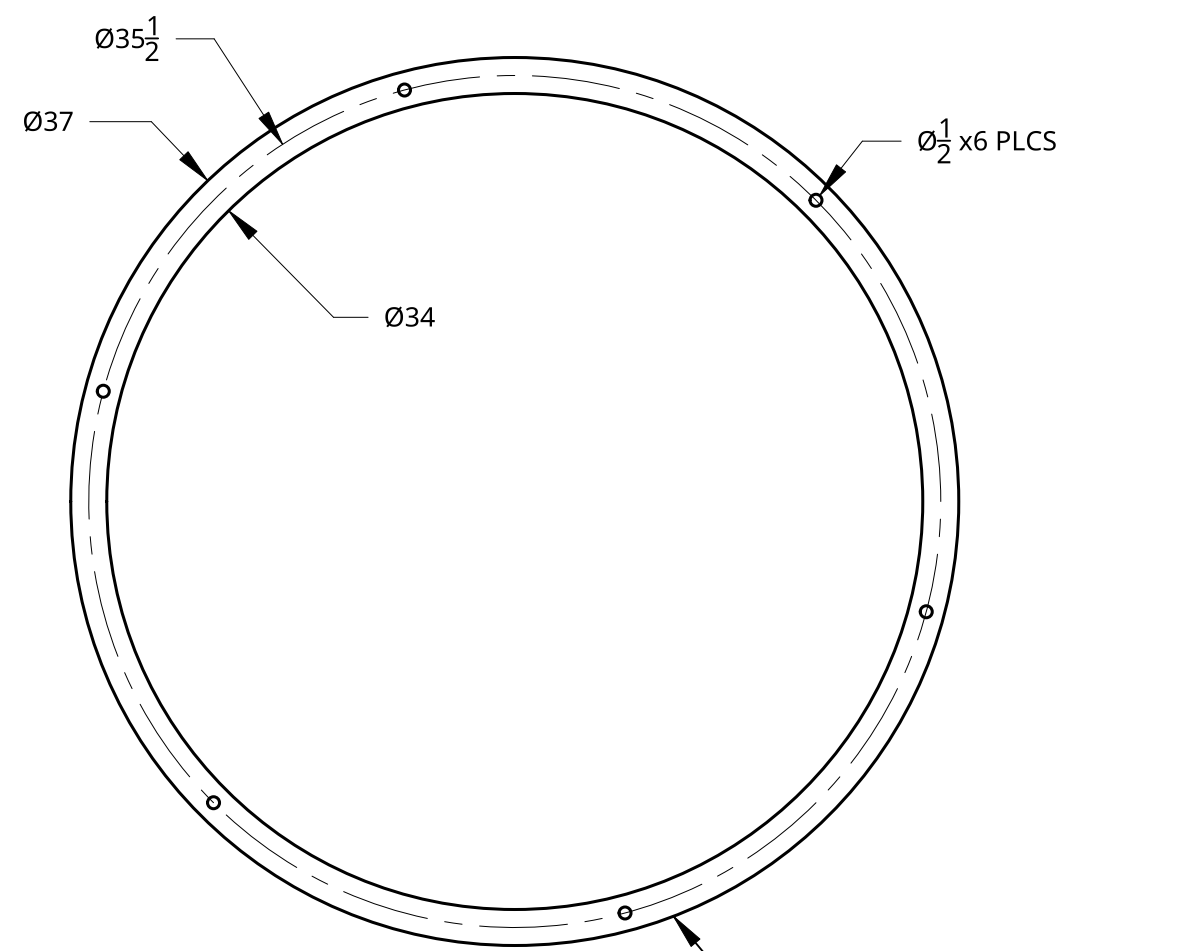

NOTE: Attach Gear to Aluminum Ring with 1/2" Bolts & Nuts

A	VAZAR INC. 3025 ELDRIDGE AVE BELLINGHAM, WA	DRAWN BY:	JOSHUA HUPP	TOLERANCES UNLESS NOTED OTHERWISE			ASSY:	FN	NEXT ASSY:		PART NO:		QTY:		SCALE	1:8
		CHECKED BY:		FRACTIONS:	$\pm 1/16"$	ANGLES:	$\pm 30'$	GEAR ASSEMBLY			MATERIAL:	ALUMINUM 1160	SIZE:	B		
		DATE CREATED:	03/02/2020	DECIMALS:	$\pm 0.10$	FINISH AS PER FS-2576	DESC:				STEEL ASTM A36	ANSI				
		LAST REVISION:	05/10/2021	WELD AS PER AC 43.13-IA STEEL			TITLE				UNIT:	DEHAVILLAND	MODEL:	DHC-3	SHEET	12 OF 23
MFG BY	REV:															

4

3

2

1

D

D

C

C

B

B

A

A

4

3

2

1

QTY	PART #	MATERIAL	DESCRIPTION
1	TRF-01	11ga Sheet Metal	OUTSIDE TROUGH EDGE
1	TRF-02	11ga Sheet Metal	TROUGH WALL
1	TRF-03	11ga Sheet Metal	INSIDE TROUGH WALL
1	TRF-04	HSS 3 x 3 x .125	CHUTE SUPPORT ARM
1	TRF-05	11ga Sheet Metal	CHUTE SUPPORT ARM CAP
1	TRF-06	A36 Plate	CHUTE SUPPORT ARM SWIVEL
2	TRF-07	HSS 2 x 1 $\frac{13}{16}$ x .125	FRONT TROUGH SUPPORT LEG
1	TRF-08	A36 Steel	DRAIN
2	TRF-09	11ga Sheet Metal	SUPPORT FLANGES

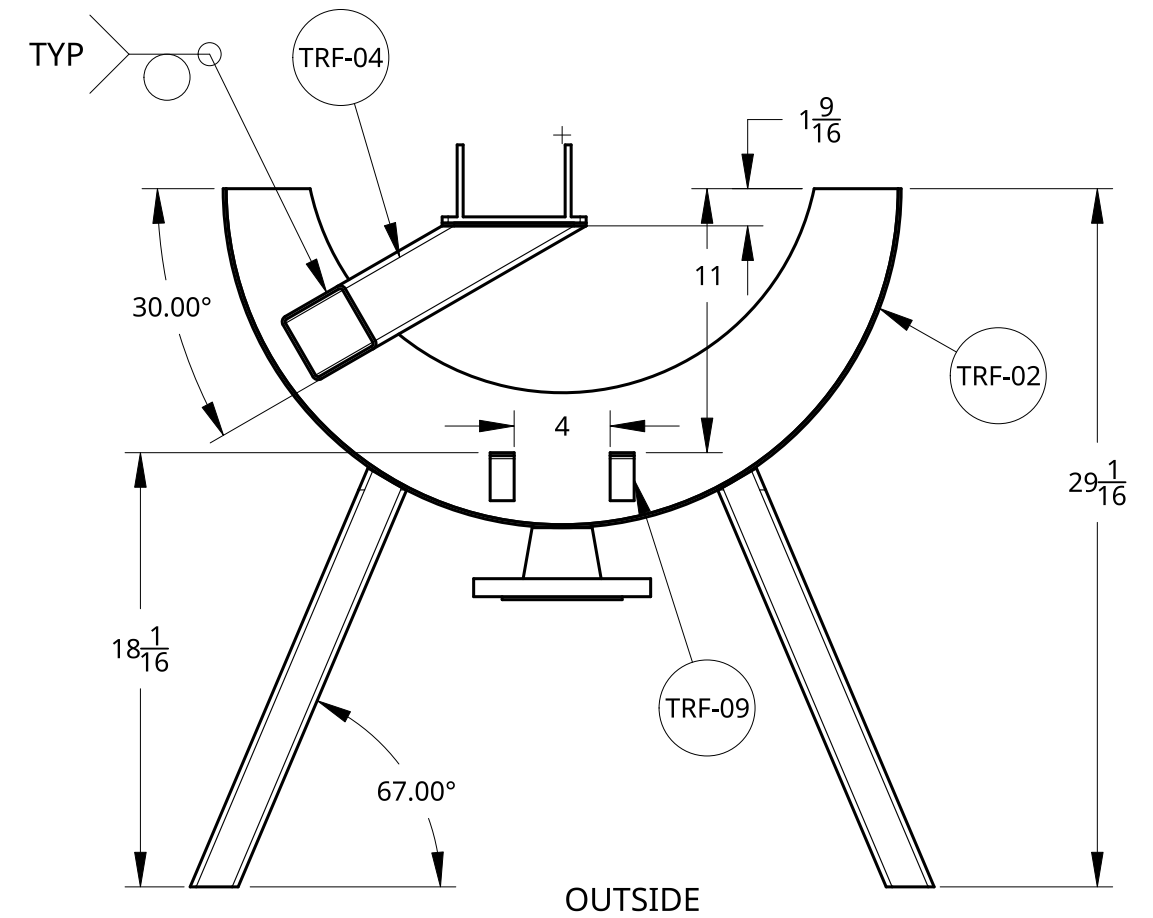
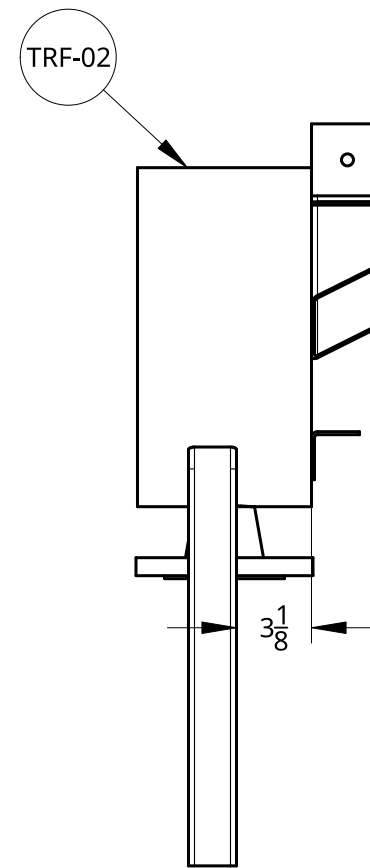
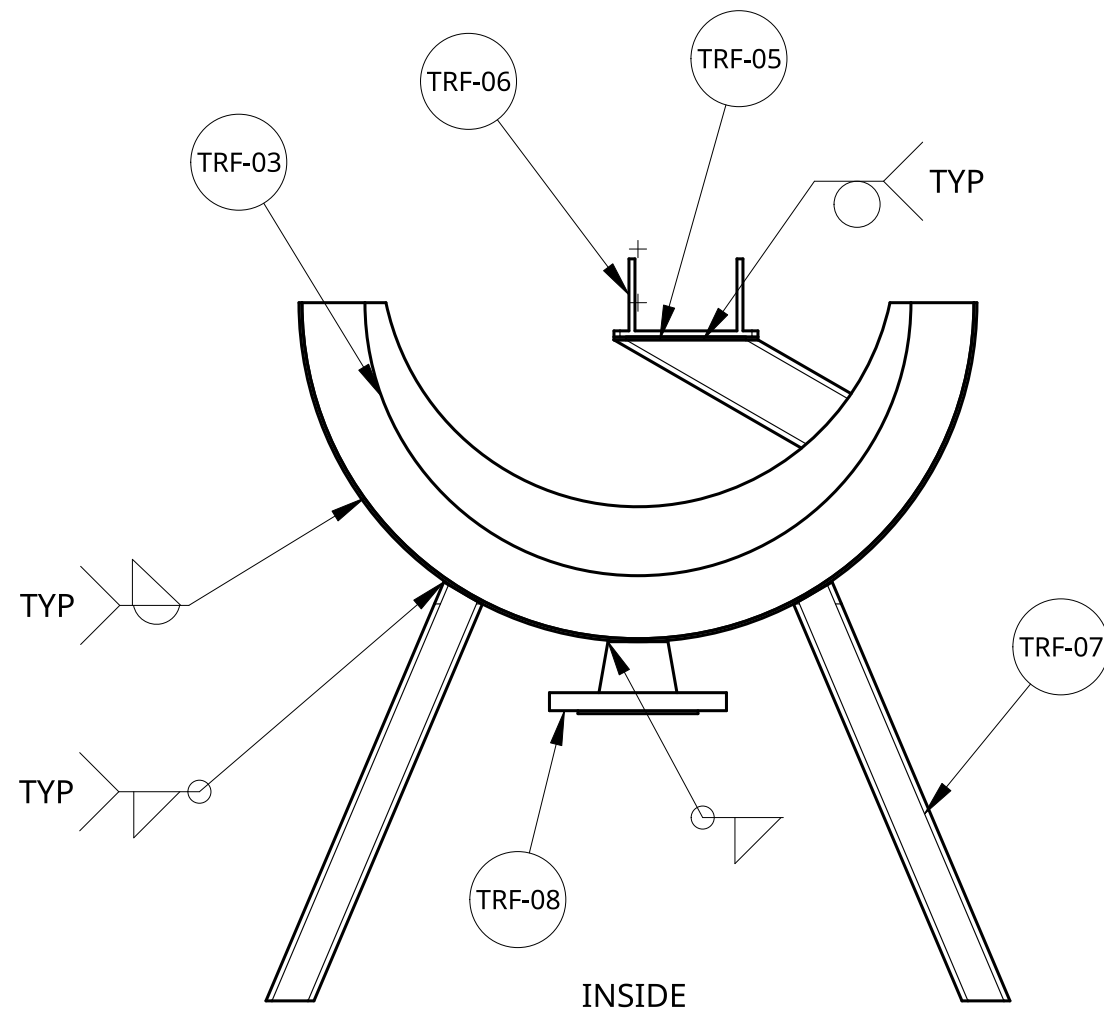

D

D

C

C

B

B

A

A

VAZAR INC. 3025 ELDRIDGE AVE BELLINGHAM, WA	DRAWN BY:	JOSHUA HUPP	TOLERANCES UNLESS NOTED OTHERWISE		ASSY:	TRF	NEXT ASSY:		PART NO:		QTY:		SCALE	1:8	
	CHECKED BY:		FRACTIONS:	$\pm 1/16"$	ANGLES:	$\pm 30'$	FRONT CONE TROUGH ASSEMBLY			MATERIAL:		A36 Steel		SIZE:	B
	DATE CREATED:	03/02/2020	DECIMALS:	$\pm 0.10$	FINISH AS PER FS-2576					DESC:		ANSI			
	LAST REVISION:	05/10/2021	WELD AS PER AC 43.13-IA STEEL			TITLE			UNIT:	DEHAVILLAND	MODEL:	DHC-3	SHEET	13 OF 23	

4

3

2

1

4

3

2

1

QTY	PART #	MATERIAL	DESCRIPTION
1	TRF-01	11ga Sheet Metal	OUTSIDE TROUGH EDGE
1	TRF-02	11 ga Sheet Metal	TROUGH WALL
1	TRF-03	11ga Sheet Metal	INSIDE TROUGH WALL
2	TRF-09	FB $\frac{1}{8}$ x 1 x $3\frac{13}{16}$	SUPPORT FLANGE

D

D

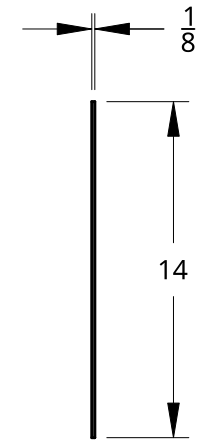
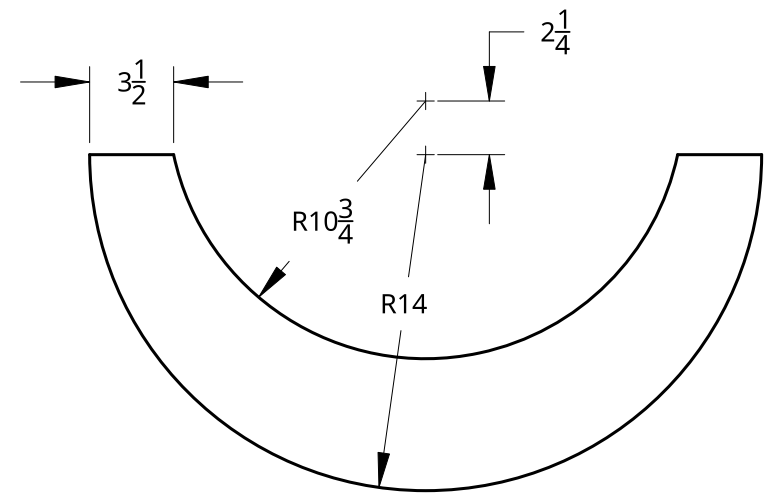

TRF-01

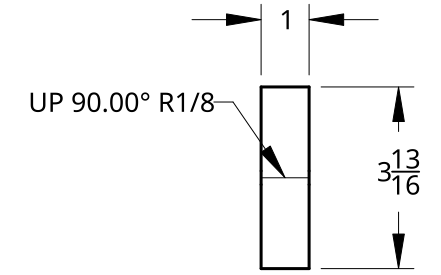
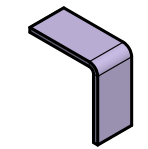
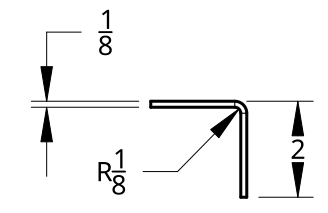

TRF-09 - Front Support Flange  
SCALE 1:4

C

C

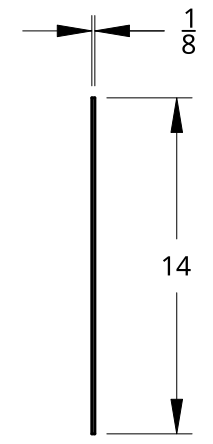
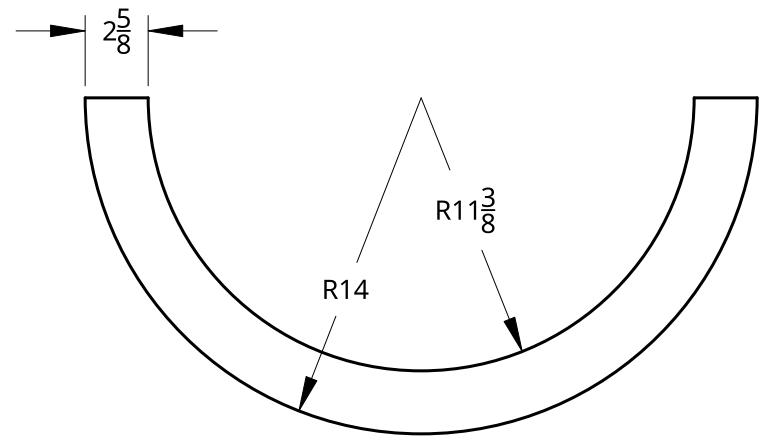

TRF-02

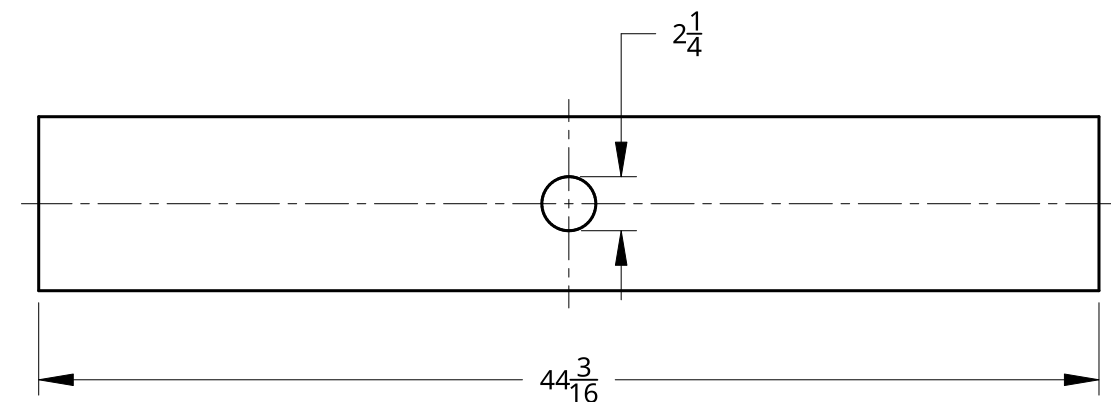

TRF-03

B

B

A

A

VAZAR INC. 3025 ELDRIDGE AVE BELLINGHAM, WA	DRAWN BY:	JOSHUA HUPP	TOLERANCES UNLESS NOTED OTHERWISE		ASSY:		NEXT ASSY:		PART NO:		QTY:	1	SCALE	1:8
	CHECKED BY:		FRACTIONS:	± 1/16"	ANGLES:	± 30'	Trough			MATERIAL:		A36 Steel	SIZE:	B
	DATE CREATED:	03/02/2020	DECIMALS:	± 0.10	FINISH AS PER FS-2576					DESC:		STEEL ASTM A36		
	LAST REVISION:	05/10/2021	WELD AS PER AC 43.13-IA STEEL		TITLE		UNIT:	DEHAVILLAND	MODEL:	DHC-3	SHEET	14 OF 23		

4

3

2

1

4

3

2

1

QTY	PART #	MATERIAL	DESCRIPTION
1	TRF-04	HSS 3 x 3 x .125	CHUTE SUPPORT ARM
2	TRF-07	HSS 2 x 1 $\frac{13}{16}$ x .125	FRONT TROUGH SUPPORT LEG

D

D

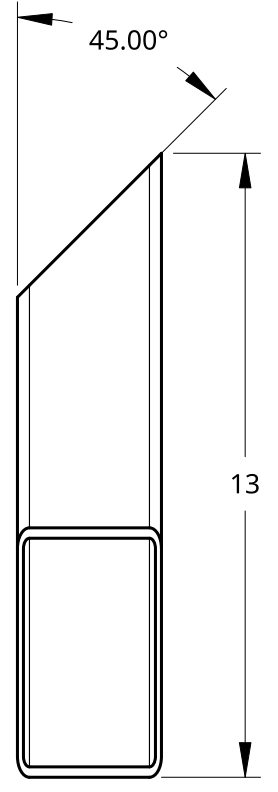

SECTION B - B

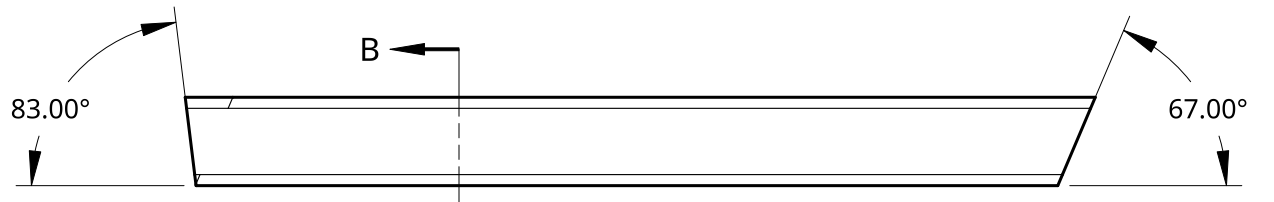
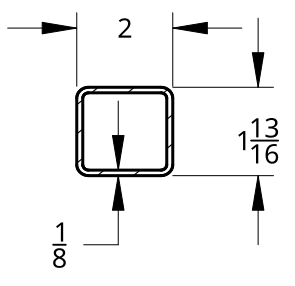

TRF-07 - Front Trough Leg

C

C

B

B

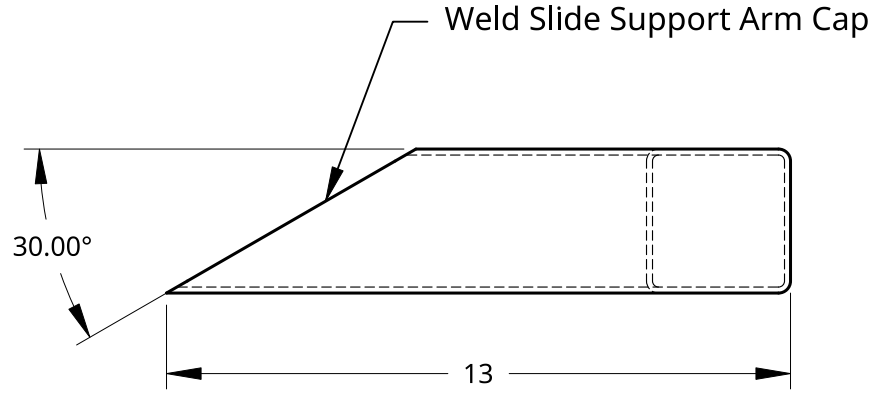
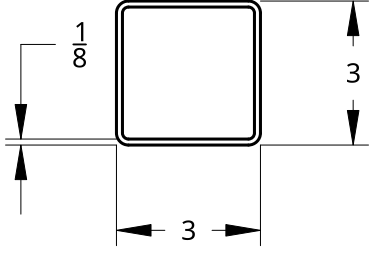

TRF-04 - Chute Support Arm

A

A

VAZAR INC. 3025 ELDRIDGE AVE BELLINGHAM, WA	DRAWN BY:	JOSHUA HUPP	TOLERANCES UNLESS NOTED OTHERWISE			ASSY:		NEXT ASSY:		PART NO:		QTY:		SCALE	1:4
	CHECKED BY:		FRACTIONS:	± 1/16"	ANGLES:	± 30'	<i>Trough Support Tubes</i>			MATERIAL:	A36 Steel		SIZE:	B	
	DATE CREATED:	03/02/2020	DECIMALS:	± 0.10						DESC:	STEEL ASTM A36		ANSI		
	LAST REVISION:	05/10/2021	FINISH AS PER FS-2576								UNIT:	DEHAVILLAND	MODEL:	DHC-3	SHEET
MFG BY	REV:		WELD AS PER AC 43.13-IA STEEL			TITLE									

4

3

2

1

4

3

2

1

QTY	PART #	MATERIAL	DESCRIPTION
1	TRF-08	A36 Steel	DRAIN

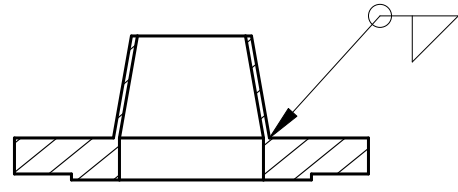
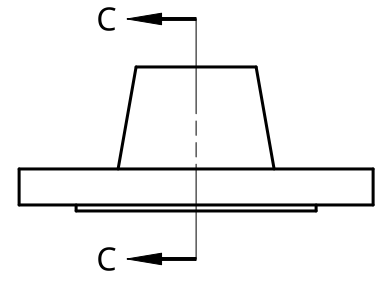

SECTION C - C

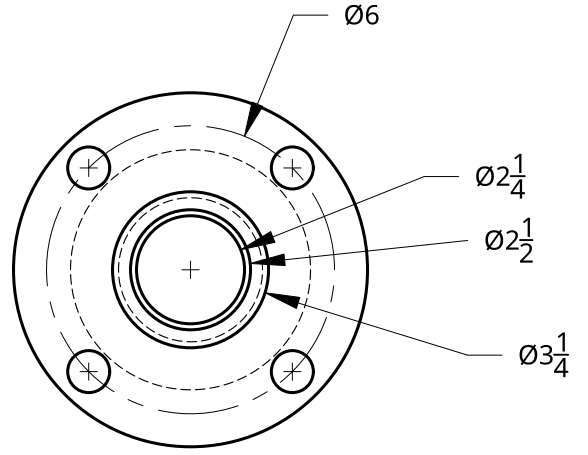
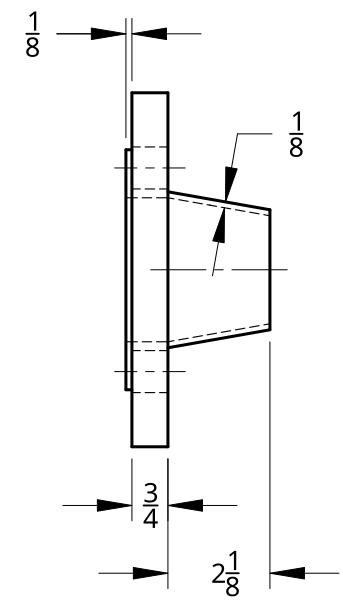
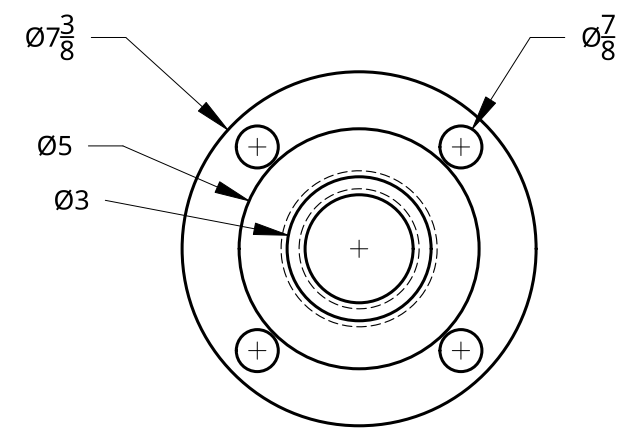
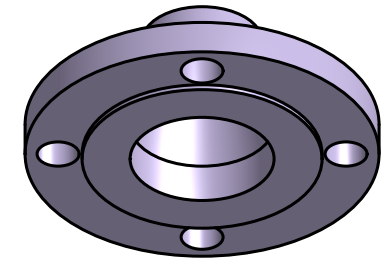
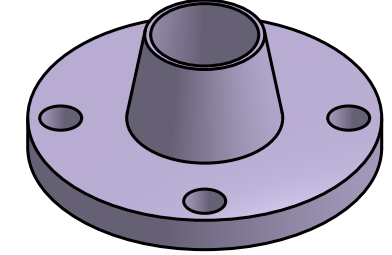

D

D

C

C

B

B

A

A

VAZAR INC. 3025 ELDRIDGE AVE BELLINGHAM, WA	DRAWN BY: JOSHUA HUPP	TOLERANCES UNLESS NOTED OTHERWISE		ASSY:	NEXT ASSY:	PART NO:	QTY:	SCALE	1:4
	CHECKED BY:	FRACTIONS: ± 1/16"	ANGLES: ± 30'	Front Trough Drain			MATERIAL: A36 Steel	SIZE:	B
	DATE CREATED: 03/02/2020	DECIMALS: ± 0.10					MATERIAL: STEEL ASTM A36	ANSI	
	LAST REVISION: 05/10/2021	FINISH AS PER FS-2576					DESC:		
MFG BY	REV:	WELD AS PER AC 43.13-IA STEEL		TITLE	UNIT: DEHAVILLAND	MODEL: DHC-3	SHEET	16 OF 23	

4

3

2

1



4

3

2

1

QTY	PART #	MATERIAL	DESCRIPTION
1	TRF-05	11ga Sheet Metal	CHUTE SUPPORT ARM CAP
2	TRF-06a	FB 1/4 x 3 x 3	CHUTE SUPPORT ARM SWIVEL ARM
1	TRF-06b	FB 1/4 x 3 x 6	CHUTE SUPPORT ARM SWIVEL BASE

D

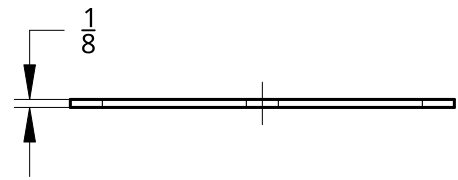

Grind edge to match tube corners (optional)

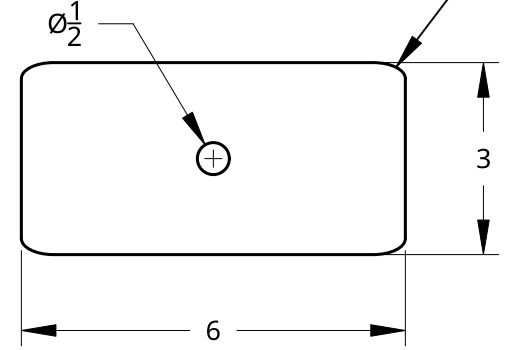

TRF-05 - Chute Support Arm Cap

C

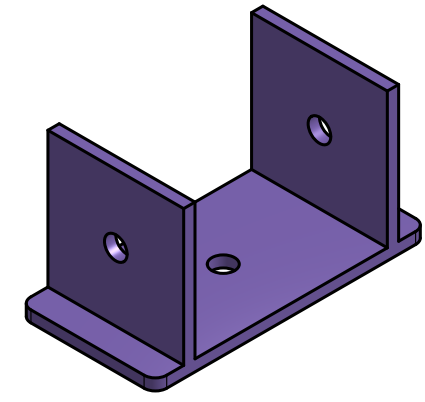

TRF-06 - Chute Support Arm Swivel

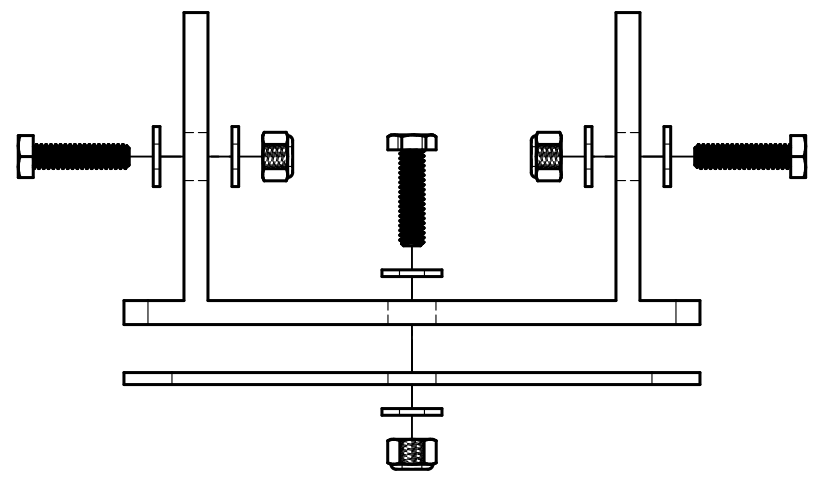

Chute Support Assembly

B

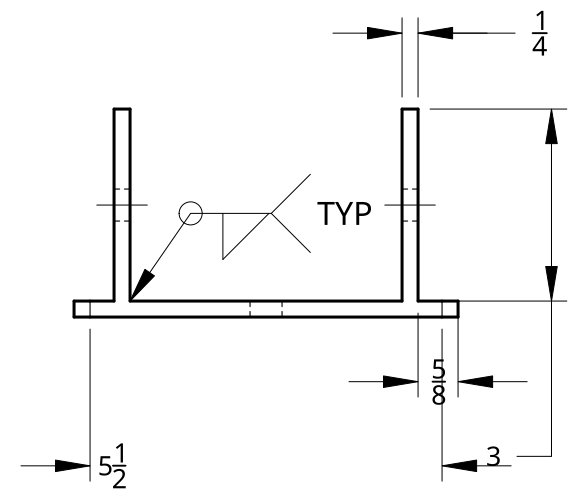
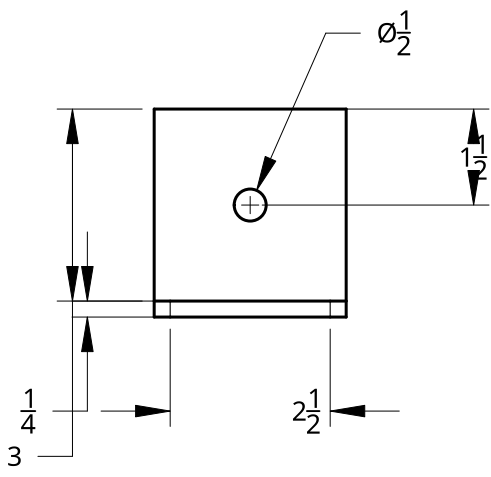

A

VAZAR INC. 3025 ELDRIDGE AVE BELLINGHAM, WA	DRAWN BY:	JOSHUA HUPP	TOLERANCES UNLESS NOTED OTHERWISE			ASSY:	TRF	NEXT ASSY:		PART NO:		QTY:		SCALE	1:3
	CHECKED BY:		FRACTIONS:	± 1/16"	ANGLES:	± 30'	CHUTE SUPPORT ASSEMBLY			MATERIAL:	A36 Steel		SIZE:	B	
	DATE CREATED:	03/02/2020	DECIMALS:	± 0.10	FINISH AS PER FS-2576					DESC:			ANSI		
	LAST REVISION:	05/10/2021	WELD AS PER AC 43.13-IA STEEL			TITLE				UNIT:	DEHAVILLAND	MODEL:	DHC-3	SHEET	17 OF 23

4

3

2

1

D

C

B

A

4

3

2

1

QTY	PART #	MATERIAL	DESCRIPTION
1	TRR-01	11ga Sheet Metal	OUTSIDE TROUGH EDGE
1	TRR-02	11 ga Sheet Metal	TROUGH WALL
1	TRR-03	11ga Sheet Metal	INSIDE TROUGH WALL
2	TRR-04	HSS 2 x 2 x .125	REAR TROUGH SUPPORT ARM
2	TRR-05	HSS 2 x 2 x .125	REAR TROUGH SUPPORT LEG
1	TRR-06	A36 Steel	REAR TROUGH DRAIN
1	TRR-07	11ga Sheet Metal	CHUTE END SUPPORT
1	TRR-08	3/8 x 4 Flat Bar	PIPE SUPPORT ARM

D

D

C

C

B

B

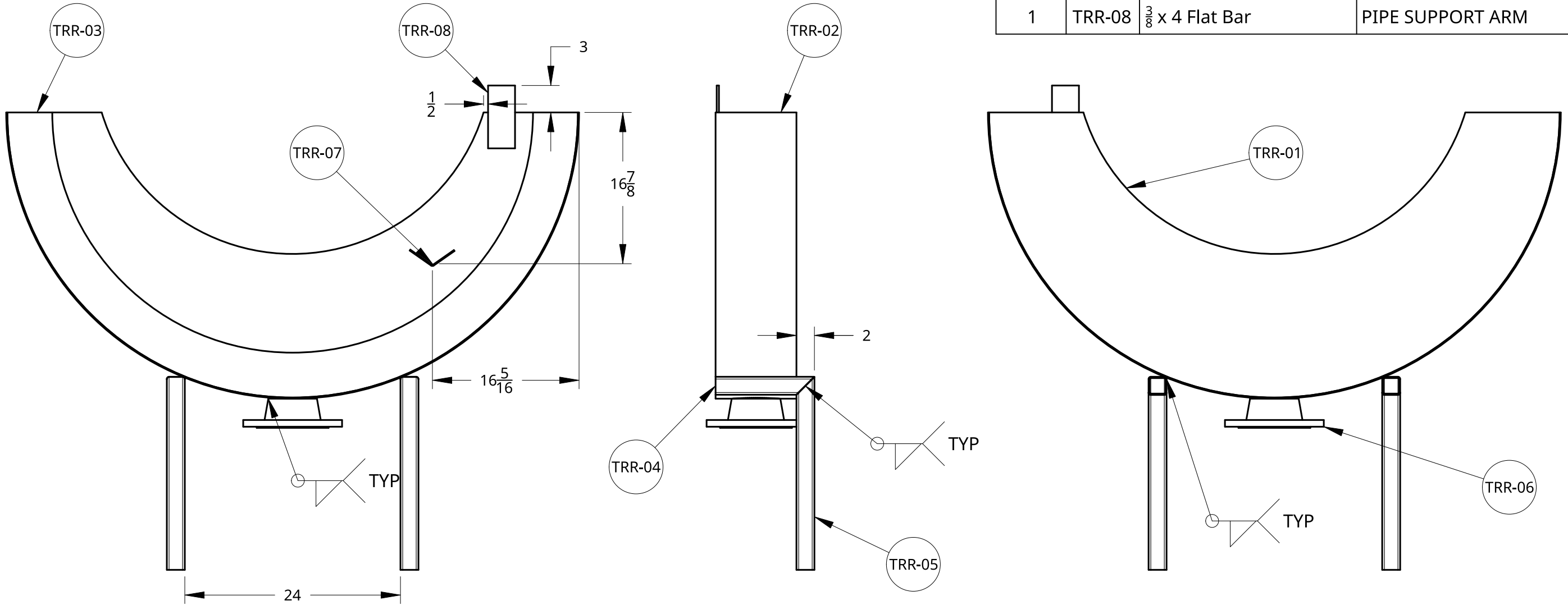

A

A

VAZAR INC. 3025 ELDRIDGE AVE BELLINGHAM, WA	DRAWN BY:	JOSHUA HUPP	TOLERANCES UNLESS NOTED OTHERWISE		ASSY:	TRR	NEXT ASSY:		PART NO:		QTY:		SCALE	1:12
	CHECKED BY:		FRACTIONS:	± 1/16"	ANGLES:	± 30'	REAR TROUGH ASSEMBLY			MATERIAL:			SIZE:	<b>B</b>
	DATE CREATED:	03/02/2020	DECIMALS:	± 0.10	FINISH AS PER FS-2576					DESC:			ANSI	
	LAST REVISION:	05/10/2021	WELD AS PER AC 43.13-IA STEEL		TITLE			UNIT:	DEHAVILLAND	MODEL:	DHC-3	SHEET	18 OF 23	

4

3

2

1

4

3

2

1

QTY	PART #	MATERIAL	DESCRIPTION
1	TRR-01	11ga Sheet Metal	OUTSIDE TROUGH EDGE
1	TRR-02	11 ga Sheet Metal	TROUGH WALL
1	TRR-03	11ga Sheet Metal	INSIDE TROUGH WALL
1	TRR-07	11ga Sheet Metal	CHUTE END SUPPORT
1	TRR-08	1/4 x 3 Flat Bar	PIPE SUPPORT ARM

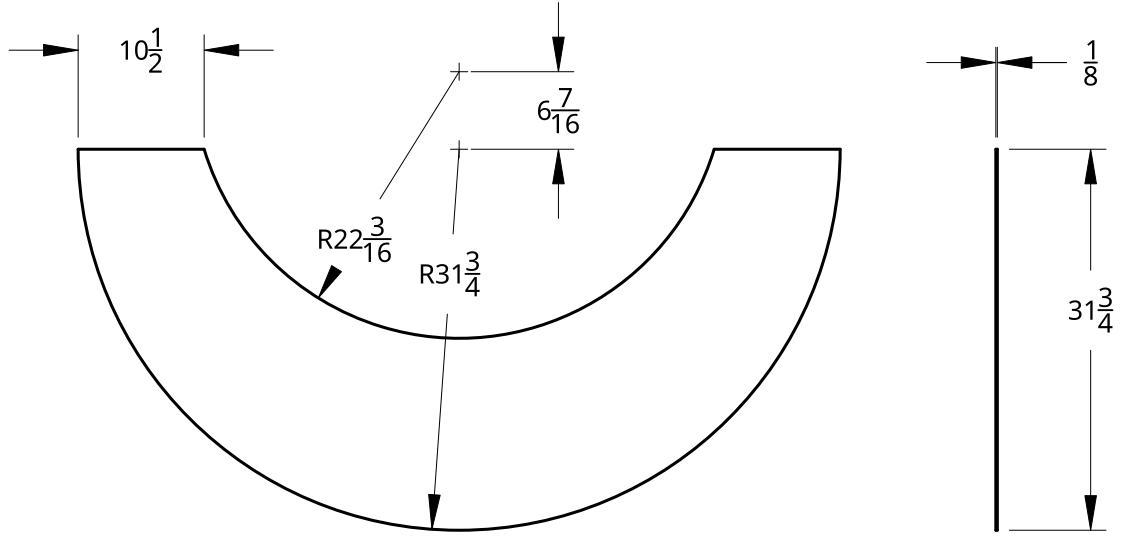

TRR-01

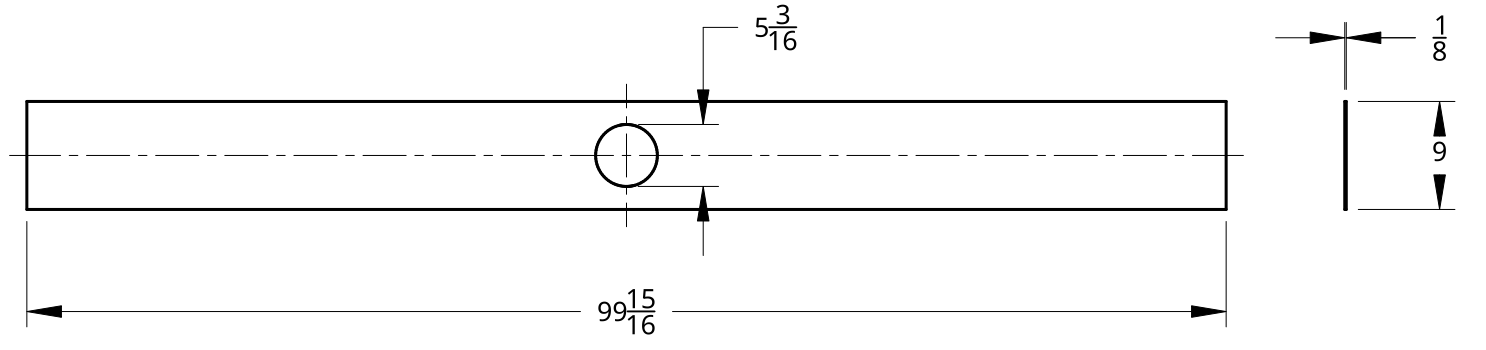

TRR-02

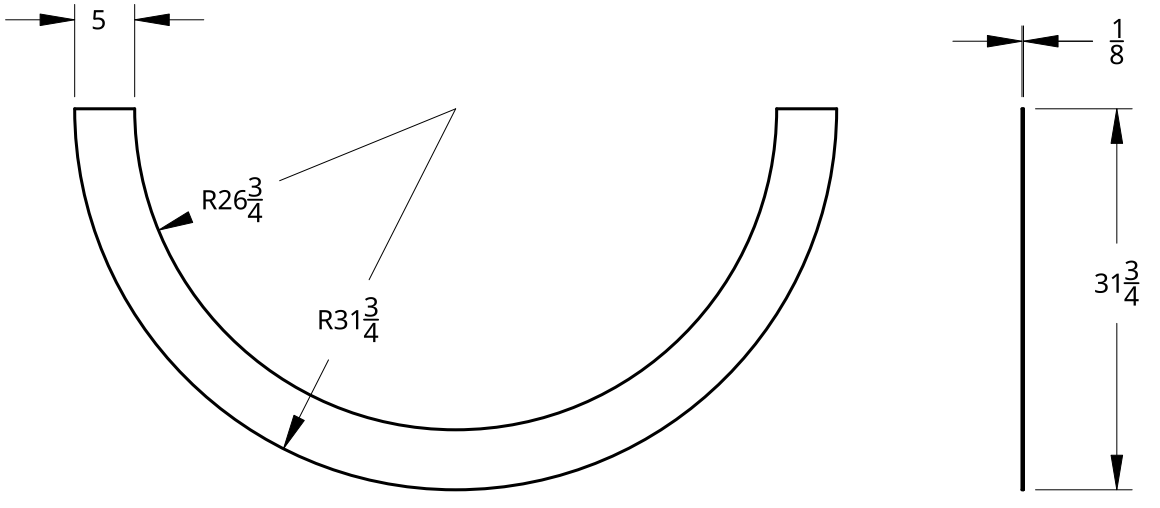

TRR-03

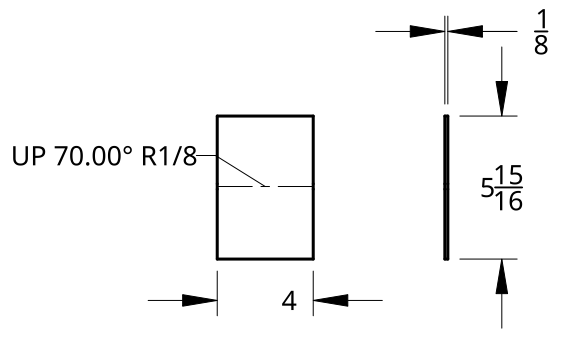

SCALE 1:8

TRR-07 - CHUTE END SUPPORT

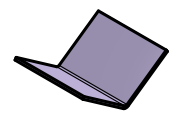

SCALE 1:8

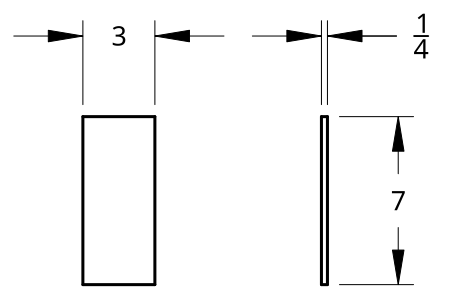

SCALE 1:8

TRR-08 - PIPE SUPPORT ARM

D

D

C

C

B

B

A

A

VAZAR INC. 3025 ELDRIDGE AVE BELLINGHAM, WA	DRAWN BY:	JOSHUA HUPP	TOLERANCES UNLESS NOTED OTHERWISE			ASSY:	TRR	NEXT ASSY:		PART NO:		QTY:		SCALE	1:16
	CHECKED BY:		FRACTIONS:	± 1/16"	ANGLES:	± 30'	REAR TROUGH ASSEMBLY				MATERIAL:	A36 Steel	SIZE:	B	
	DATE CREATED:	03/02/2020	DECIMALS:	± 0.10	FINISH AS PER FS-2576						MATERIAL:	11ga Sheet Metal	ANSI		
	LAST REVISION:	05/10/2021	WELD AS PER AC 43.13-IA STEEL								TITLE	UNIT:	DEHAVILLAND	MODEL:	DHC-3
MFG BY	REV:														

4

3

2

1

4

3

2

1

QTY	PART #	MATERIAL	DESCRIPTION
2	TRR-04	HSS 2 x 2 x .125	REAR TROUGH SUPPORT ARM
2	TRR-05	HSS 2 x 2 x .125	REAR TROUGH SUPPORT LEG

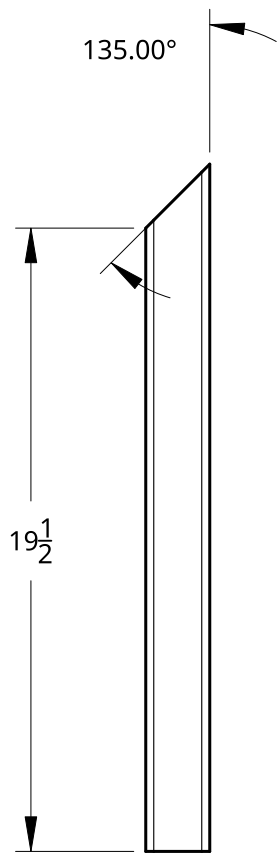
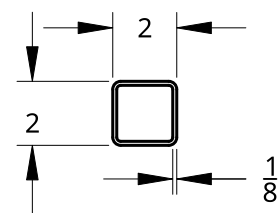

TRR-05 - Rear Trough Support Legs

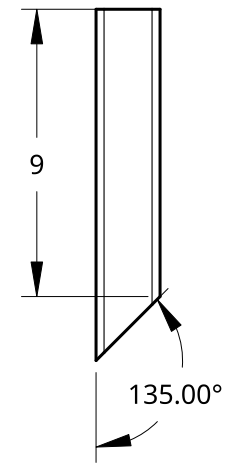
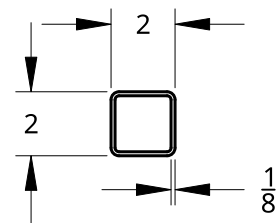

TRR-04 - Rear Trough Support Arm



D

D

C

C

B

B

A

A

VAZAR INC. 3025 ELDRIDGE AVE BELLINGHAM, WA	DRAWN BY:	JOSHUA HUPP	TOLERANCES UNLESS NOTED OTHERWISE			ASSY:	TRR	NEXT ASSY:		PART NO:		QTY:		SCALE	1:6
	CHECKED BY:		FRACTIONS:	± 1/16"	ANGLES:	± 30'	REAR TROUGH SUPPORT			MATERIAL:	A36 Steel		SIZE:	B	
	DATE CREATED:	03/02/2020	DECIMALS:	± 0.10						DESC:	2x2x.125 SST		ANSI		
	LAST REVISION:	05/10/2021	FINISH AS PER FS-2576												
MFG BY	REV:		WELD AS PER AC 43.13-IA STEEL			TITLE			UNIT:	DEHAVILLAND	MODEL:	DHC-3	SHEET	20 OF 23	

4

3

2

1

4

3

2

1

QTY	PART #	MATERIAL	DESCRIPTION
1	TRR-06	A36 Steel	REAR TROUGH DRAIN

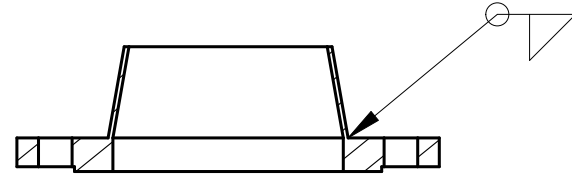
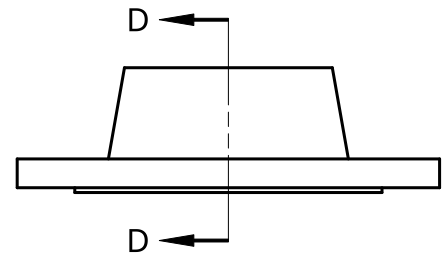

SECTION D - D

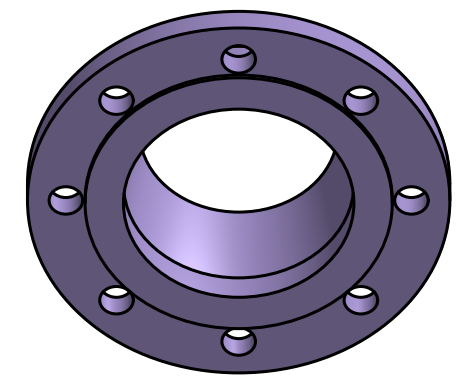
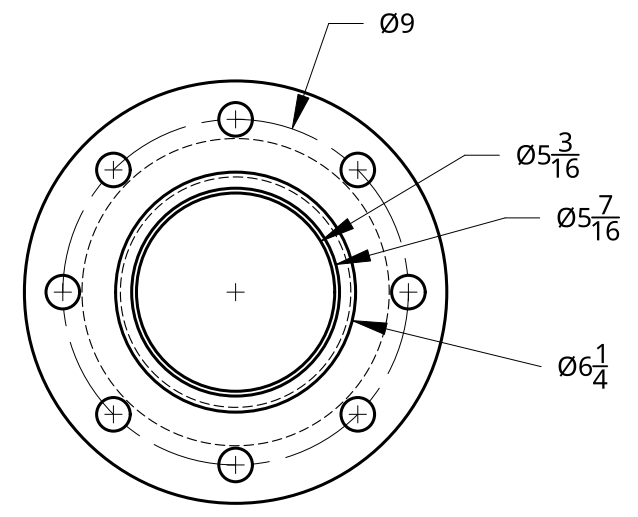
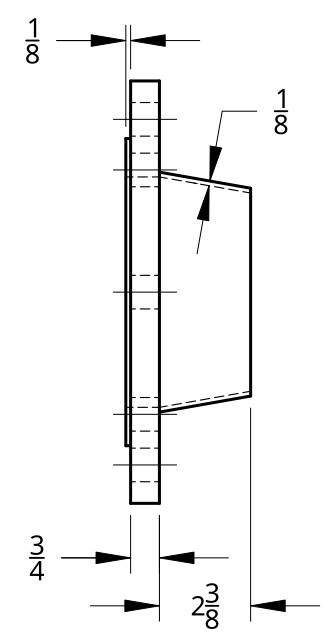
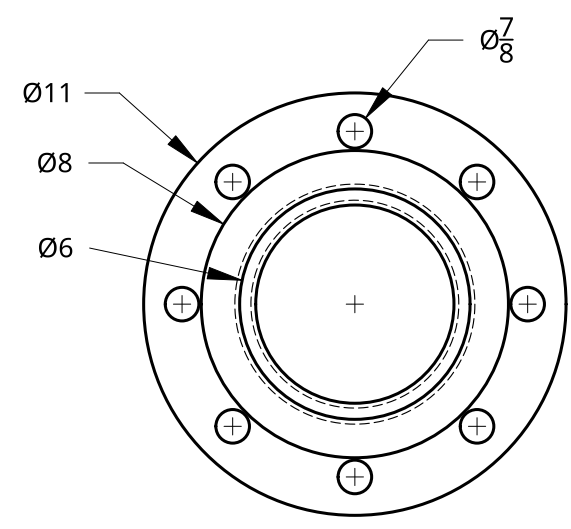
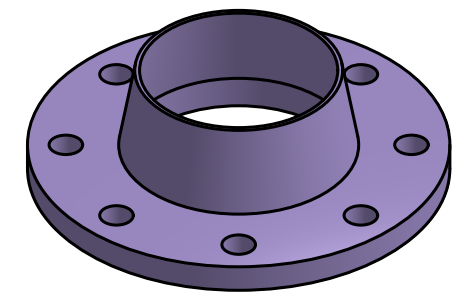

D

D

C

C

B

B

A

A

VAZAR INC. 3025 ELDRIDGE AVE BELLINGHAM, WA	DRAWN BY:	JOSHUA HUPP	TOLERANCES UNLESS NOTED OTHERWISE			ASSY:	TRR	NEXT ASSY:		PART NO:		QTY:		SCALE	1:5
	CHECKED BY:		FRACTIONS:	± 1/16"	ANGLES:	± 30'	Rear Trough Drain				MATERIAL:	A36 Steel	SIZE:	B	
	DATE CREATED:	03/02/2020	DECIMALS:	± 0.10	FINISH AS PER FS-2576						DESC:		ANSI		
	LAST REVISION:	05/10/2021	WELD AS PER AC 43.13-IA STEEL			TITLE				UNIT:	DEHAVILLAND	MODEL:	DHC-3	SHEET	21 OF 23

4

3

2

1

4

3

2

1

QTY	PART #	MATERIAL	DESCRIPTION
1	CB-01	11ga Sheet Metal	CONTROL BOX
1	CB-01	11 ga Sheet Metal	SUPPORT HINGE

D

D

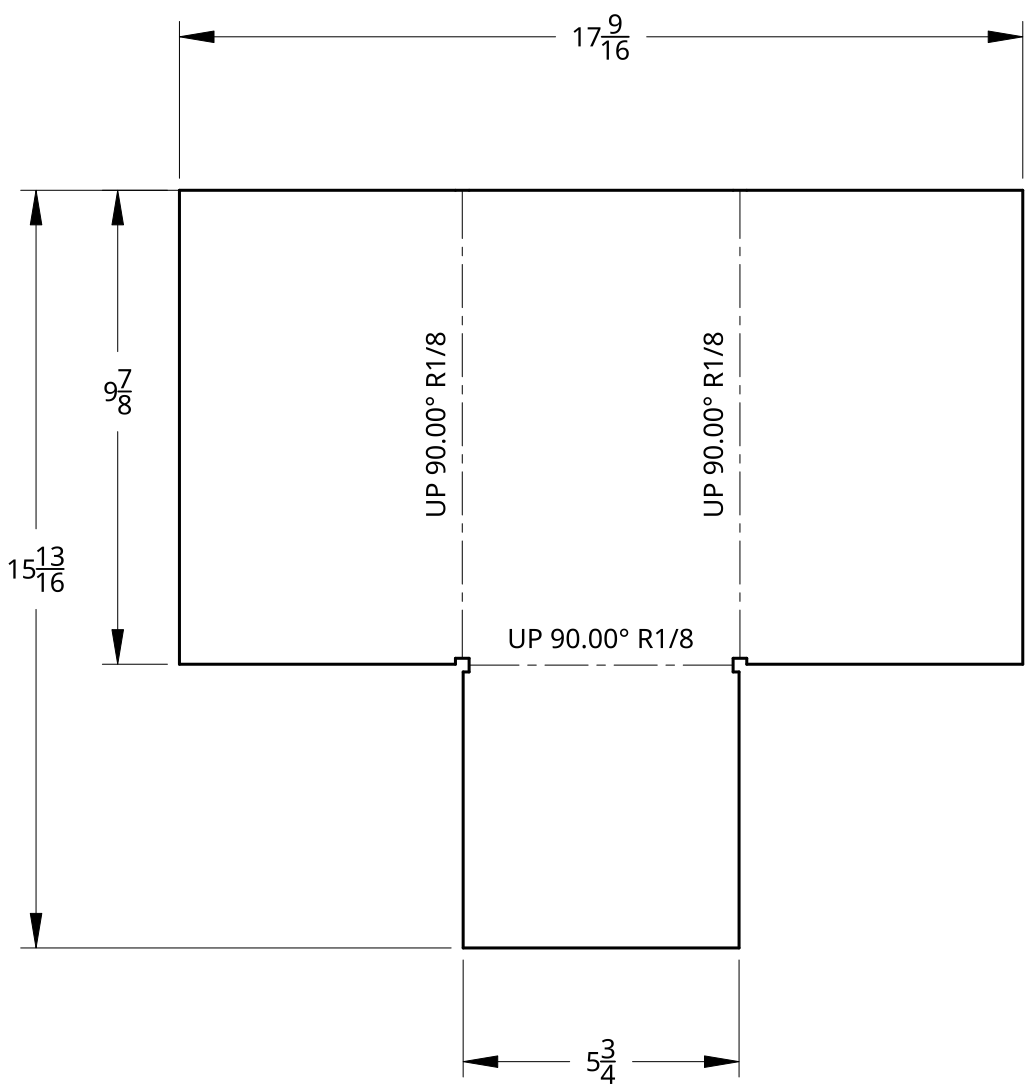

CB-01 CONTROL BOX

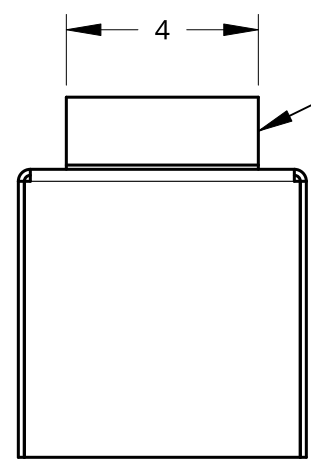

CB-02 SUPPORT HINGE  
1/8 x 2 x 4

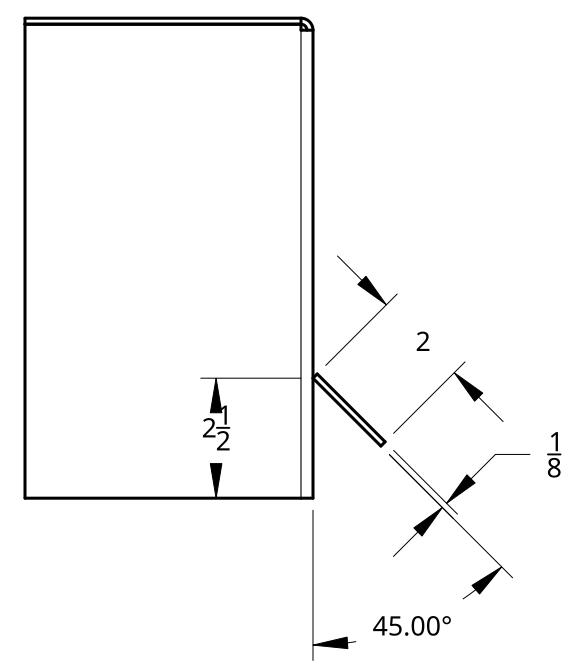
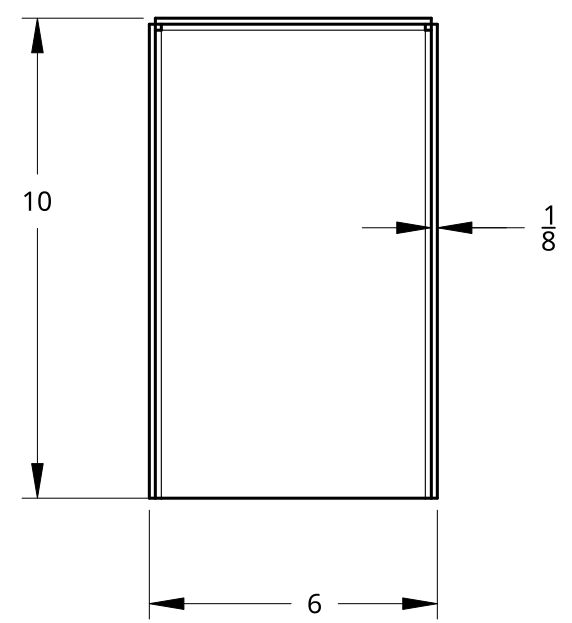

C

C

B

B

A

A

VAZAR INC. 3025 ELDRIDGE AVE BELLINGHAM, WA	DRAWN BY:	JOSHUA HUPP	TOLERANCES UNLESS NOTED OTHERWISE			ASSY:	CB	NEXT ASSY:		PART NO:	CB-ASSY	QTY:	1	SCALE	1:4
	CHECKED BY:		FRACTIONS:	± 1/16"	ANGLES:	± 30'	CONTROL BOX			MATERIAL:	A36		SIZE:	B	
	DATE CREATED:	03/02/2020	DECIMALS:	± 0.10	FINISH AS PER FS-2576					DESC:	---		ANSI		
	LAST REVISION:	10/10/2020	WELD AS PER AC 43.13-IA STEEL			TITLE			UNIT:	DEHAVILLAND	MODEL:	DHC-3	SHEET	19 OF 22	

4

3

2

1

4

3

2

1

QTY	PART #	MATERIAL	DESCRIPTION
1	LD-01	11ga Sheet Metal	LOADER BUCKET
1	LD-02	11 ga Sheet Metal	LOADER BUCKET CAP
1	LD-03	11ga Sheet Metal	LOADER CHUTE
1	LD-04	1- $\frac{1}{2}$ Pipe	LOADER VALVE
1	LD-05	11ga Sheet Metal	LOADING CHUTE SUPPORT BRACKET
1	LD-06	A36 Steel	PIPE SUPPORT BRACKET
1	TRR-07	11ga Sheet Metal	CHUTE END SUPPORT
1	TRR-08	$\frac{3}{8}$ x 4 Flat Bar	PIPE SUPPORT FLANGE

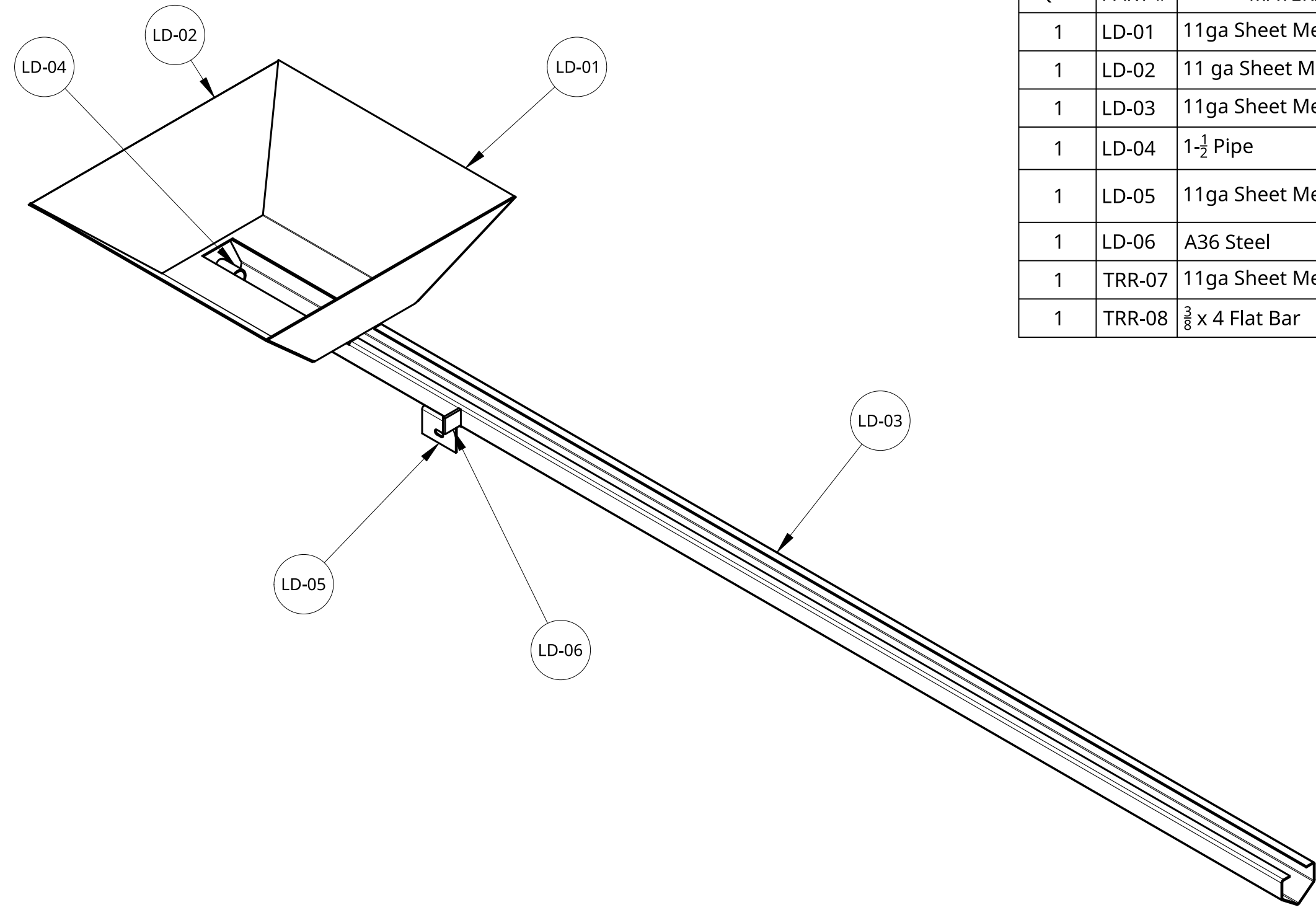

D

D

C

C

B

B

A

A

VAZAR INC. 3025 ELDRIDGE AVE BELLINGHAM, WA	DRAWN BY:	JOSHUA HUPP	TOLERANCES UNLESS NOTED OTHERWISE			ASSY:	LD	NEXT ASSY:		PART NO:		QTY:		SCALE	1:10
	CHECKED BY:		FRACTIONS:	$\pm 1/16"$	ANGLES:	$\pm 30'$	LOADER ASSEMBLY				MATERIAL:		SIZE:	B	
	DATE CREATED:	03/02/2020	DECIMALS:	$\pm 0.10$							DESC:		ANSI		
	LAST REVISION:	05/10/2021	FINISH AS PER FS-2576												
MFG BY	REV:		WELD AS PER AC 43.13-IA STEEL			TITLE			UNIT:	DEHAVILLAND	MODEL:	DHC-3	SHEET	23 OF 23	

4

3

2

1