

2

1

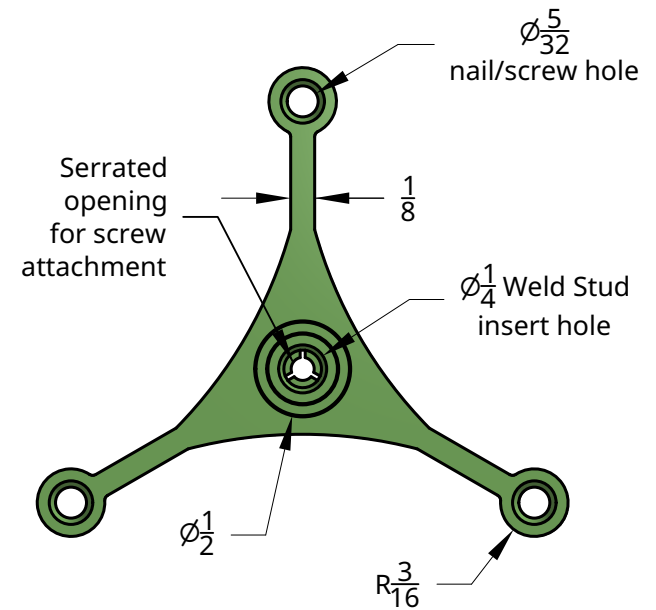
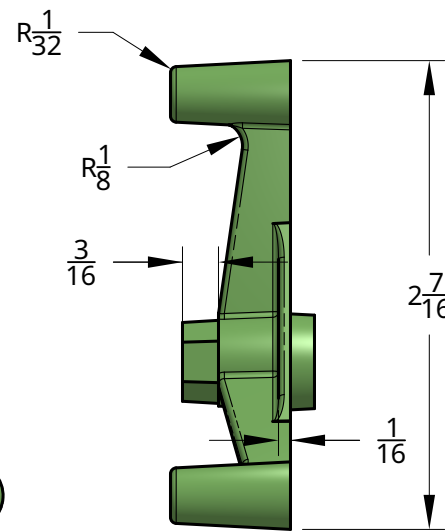
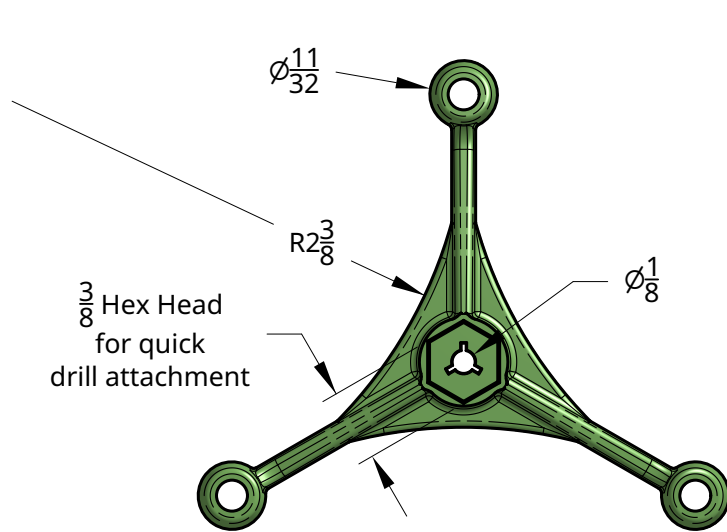
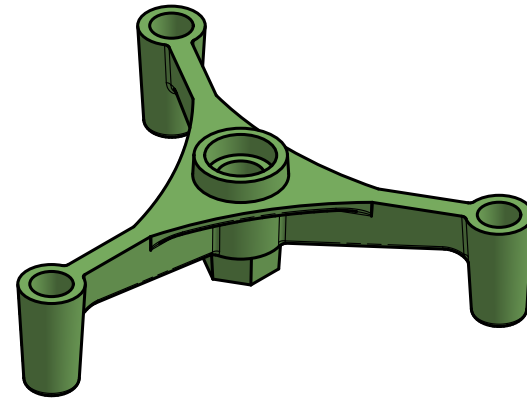
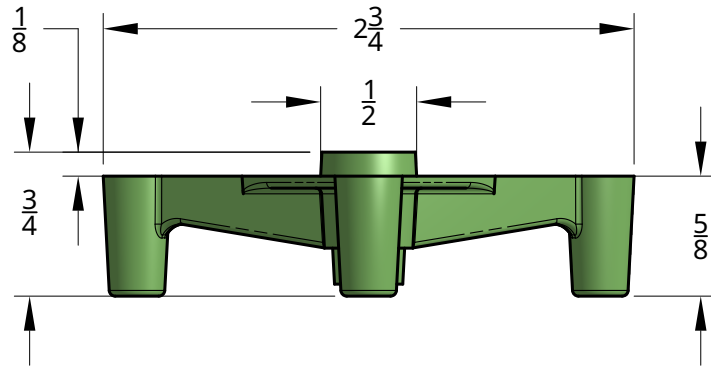

NOTE: 3 degree draft on all extrusions for injection molding

CUSTOMER:		MATERIAL:		QTY:		DATE CREATED	THIS DOCUMENT IS THE PROPERTY OF
DWG NO:	STUD RAIL SWIVEL ASSEMBLY	THICKNESS:		SCALE	1:1	05/11/2020	MORSE STEEL
		TOLERANCE:	+/- 1/16" U.N.O.	SHEET	3 OF 4	LAST REVISION	
DRAWN BY:	JOSHUA HUPP	FUEL:		ANSI: A	REV: 2	07/04/2020	ANY USE OF OR REPRODUCTION WITHOUT WRITTEN PERMISSION IS PROHIBITED

2

1