

PRODUCTSPECIFICATION:		QTY:	FINISHING:
A	120° L-SHAPE WORKTOP 1200L X 1200D X 700D X 700D C/W HATCH HOLE & SCALLOP WITH ABS EDGING	3	ZAORA OAK 7315
B	EDGE METAL BASE C/W 2 FRONT CONNECTOR 1380L X 725H	3	BLACK
C	3 WAY 120° CONNECTION BASE C/W CABLE PANEL 725H	1	BLACK
D	120° BEAM (1200L X 1200W)	3	BLACK
E	HALF HANGING PANEL BRACKET L/R	6	
F	FRAMELESS TRANS 20 PANEL 900L X 750H	3	GA910 SILVER
G	WOODEN FLIPPER 180° C/WBRUSH & SOFT CLOSE 400L	3	ZAORA OAK 7315
H	WIRE TRAY 900L	3	BLACK
I	GROMMET HOLE WITH CAP 60D	3	BLACK
TOTAL SET: 5		PERSPECTIVE VIEW ALL DIMENSION IS IN MM	



MATIC OFFICE SYSTEM SDN BHD (547300-D)
45E-2A, (TINGKAT 2) BANGUNAN BANGSARIA
Jalan Maarof, Bangsar Baru, Bangsar
59000 Kuala Lumpur
t. +60322012045 f. +60322016024
urf. www.matic.com.my

CLIENT'S CONFIRMATION & APPROVAL

COMPANY : DMX GROUP (MALAYSIA) SDN BHD

REPRESENTATIVE NAME : JAMES

DATE :06.03.2023

SIGNATURE & COMPANY STAMP

PROJECT INFORMATION :

DRAWING NO:001/22/R0

FURNITURE TYPE : EDGE CLUSTER OF 3

DRAWING TYPE : ITEM 1

QUOTATION NO : M00888-22 R10

DRAWING INFORMATION :

DRAWN BY : FARAH

CHECKED BY: YIN QIAN/SEECAY

B.D. NAME : JEFT

PROJECT ID : MT23-P0022

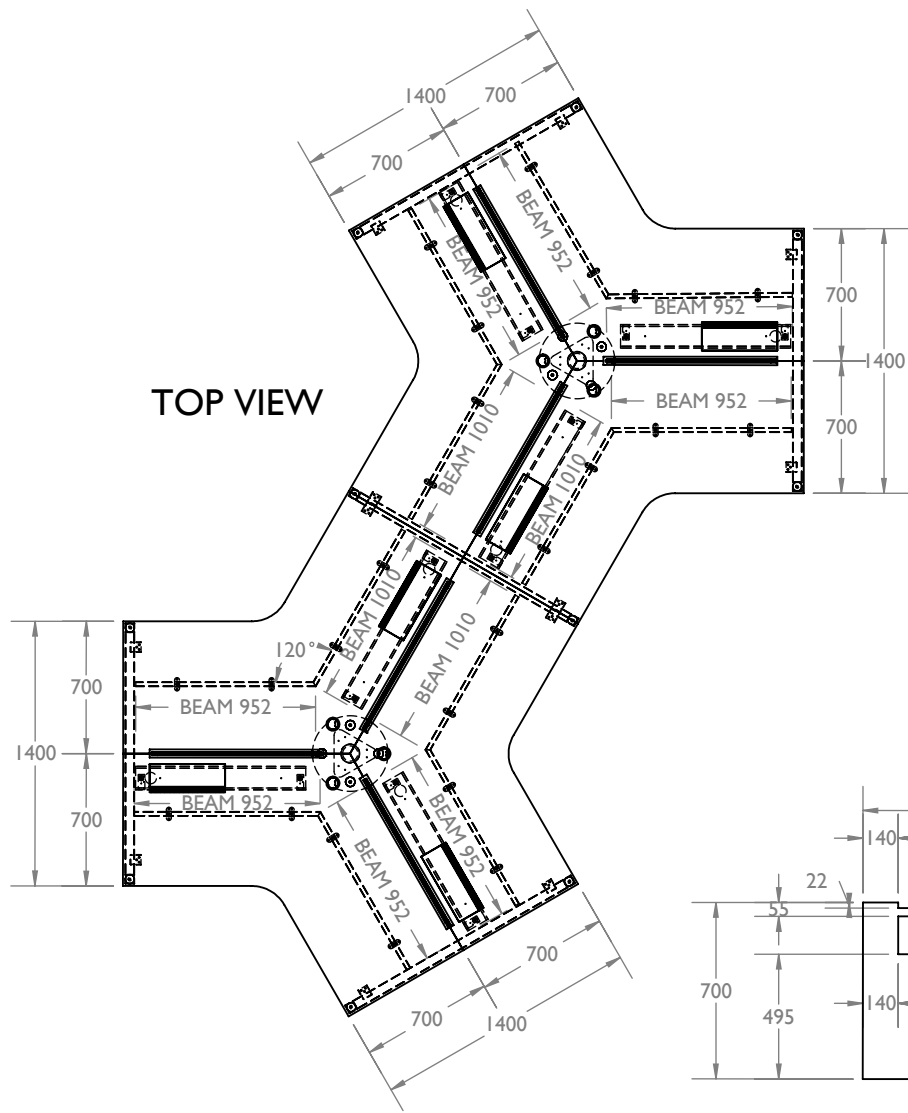

TOP VIEW

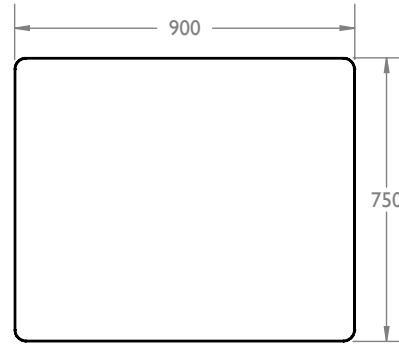

TRANS 20 PANEL

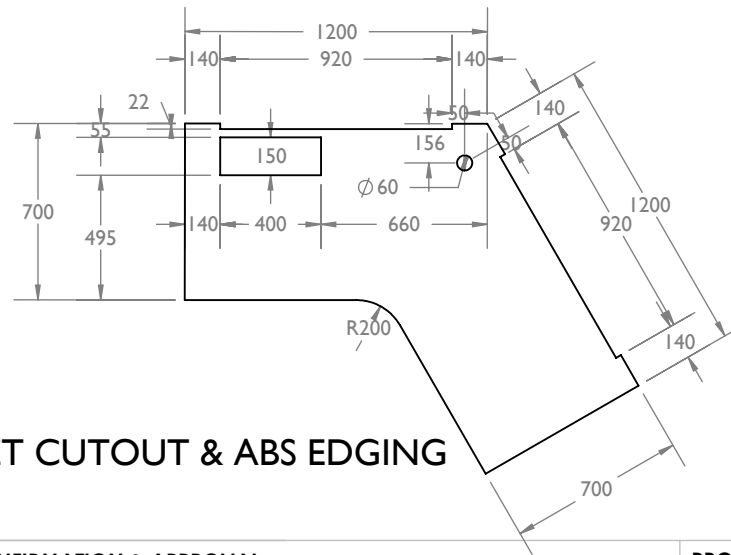

FLIPPER, GROMMET CUTOUT & ABS EDGING

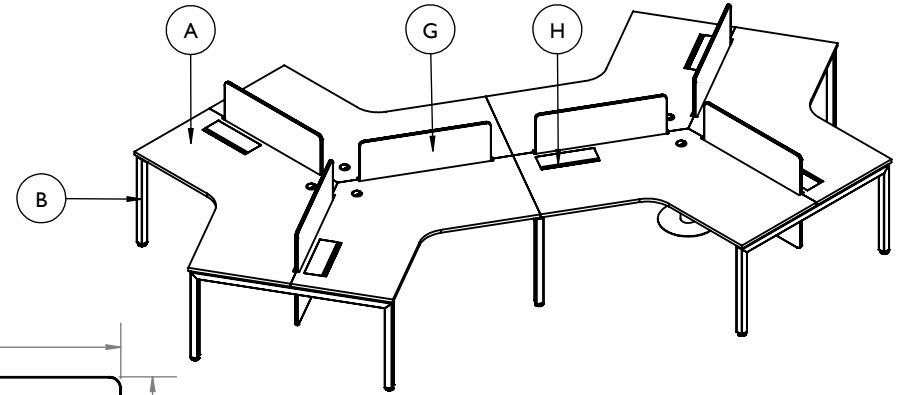

PRODUCTSPECIFICATION:		QTY:	FINISHING:
A	120° L-SHAPE WORKTOP 1200L X 1200D X 700D C/W HATCH HOLE & SCALLOP WITH ABS EDGING	6	ZAORA OAK 7315
B	EDGE METAL BASE C/W 2 FRONT CONNECTOR 1380L X 725H	4	BLACK
C	EDGE METAL BASE C/W 2 FRONT & 2 BACK CONNECTOR 1380L X 725H	1	BLACK
D	120° BEAM (1200L X 1200W)	6	BLACK
E	3 WAY 120° CENTER CONNECTION BASE C/W CABLE PANEL 725H	2	BLACK
F	HALF HANGING PANEL BRACKET L/R	12	
G	FRAMELESS TRANS 20 PANEL 900L X 750H	6	GA910 SILVER
H	WOODEN FLIPPER 180° C/W BRUSH & SOFT CLOSE 400L	6	ZAORA OAK 7315
I	WIRE TRAY 900L	6	BLACK
J	GROMMET HOLE WITH CAP 60D	6	BLACK
TOTAL SET: 7		PERSPECTIVE VIEW ALL DIMENSION IS IN MM	



MATIC OFFICE SYSTEM SDN BHD (547300-D)
45E-2A, (TINGKAT 2) BANGUNAN BANGSARIA
Jalan Maarof, Bangsar Baru, Bangsar
59000 Kuala Lumpur
t. +60322012045 f. +60322016024
urf. www.matic.com.my

CLIENT'S CONFIRMATION & APPROVAL

COMPANY : DMX GROUP (MALAYSIA) SDN BHD

REPRESENTATIVE NAME : JAMES

DATE : 06.03.2023

SIGNATURE & COMPANY STAMP

PROJECT INFORMATION :

DRAWING NO:002/22/R0

FURNITURE TYPE : EDGE CLUSTER OF 6

DRAWING TYPE : ITEM 2

QUOTATION NO : M00888-22 R10

DRAWING INFORMATION :

DRAWN BY : FARAH

CHECKED BY: YIN QIAN

B.D. NAME : JEFT

PROJECT ID : MT23-P0022

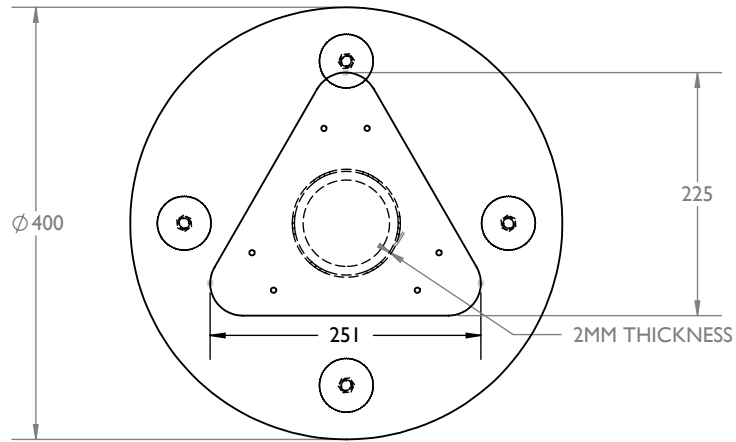

TOP VIEW

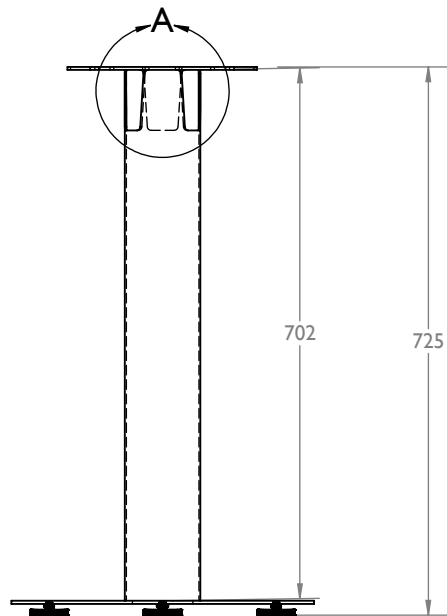

FRONT VIEW

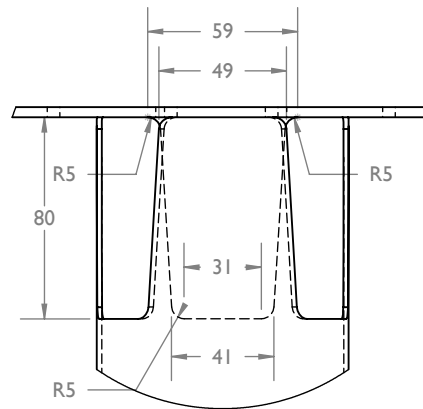

DETAIL A

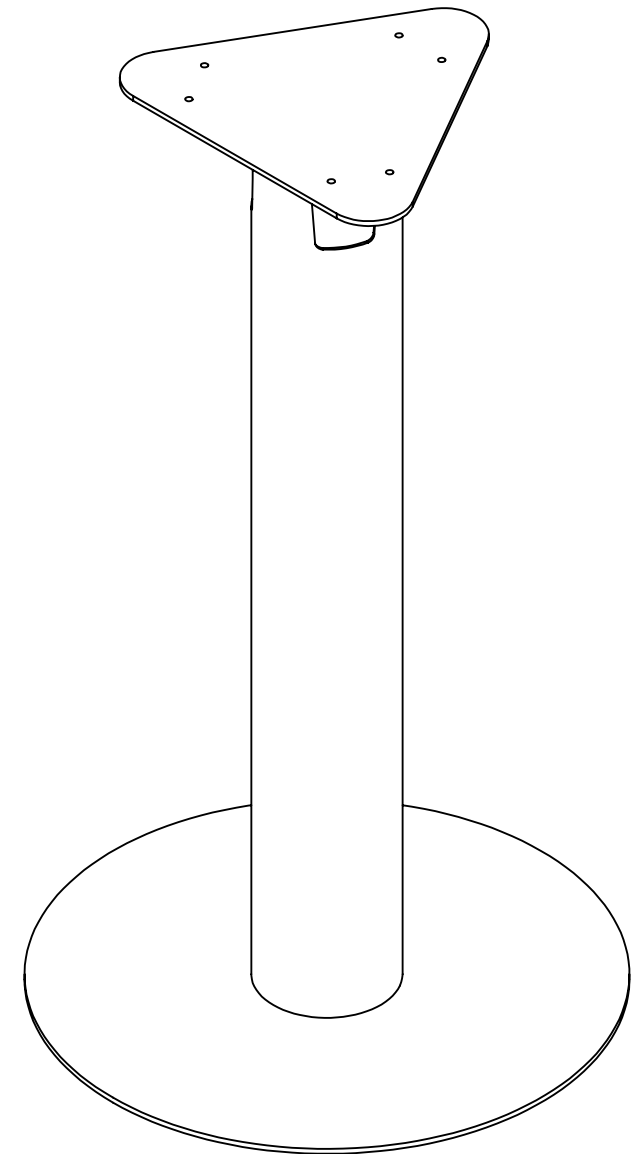

ISOMETRIC VIEW



MATIC OFFICE SYSTEM SDN BHD (547300-D)
 45E-2A, (TINGKAT 2) BANGUNAN BANGSARIA
 Jalan Maarof, Bangsar Baru, Bangsar
 59000 Kuala Lumpur
 t. +60322012045 f. +60322016024
 urf. www.matic.com.my

CLIENT'S CONFIRMATION & APPROVAL

COMPANY : DMX GROUP (MALAYSIA) SDN BHD

REPRESENTATIVE NAME : JAMES

DATE : 06.03.2023

SIGNATURE & COMPANY STAMP

PROJECT INFORMATION :

DRAWING NO:002/22/R0

FURNITURE TYPE : 120° CENTER CONNECTION BASE

DRAWING TYPE : DETAIL DRAWING

QUOTATION NO : M00888-22 R10

DRAWING INFORMATION :

DRAWN BY : FARAH

CHECKED BY: YIN QIAN

B.D. NAME : JEFT

PROJECT ID : MT23-P0022

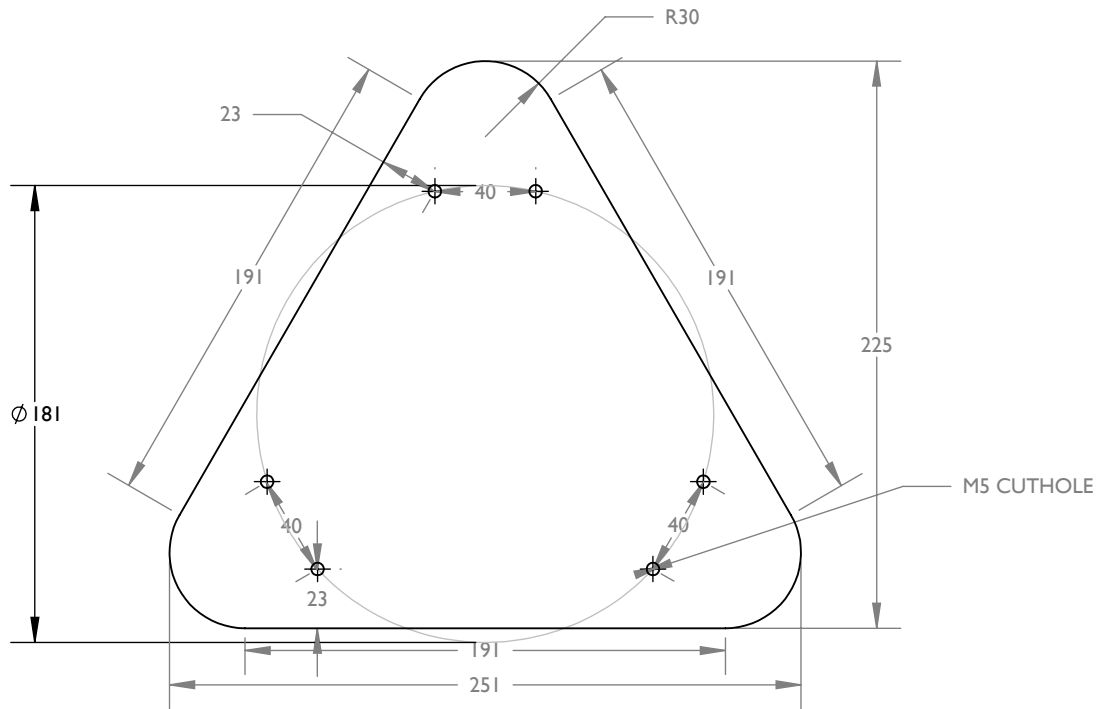

TOP VIEW

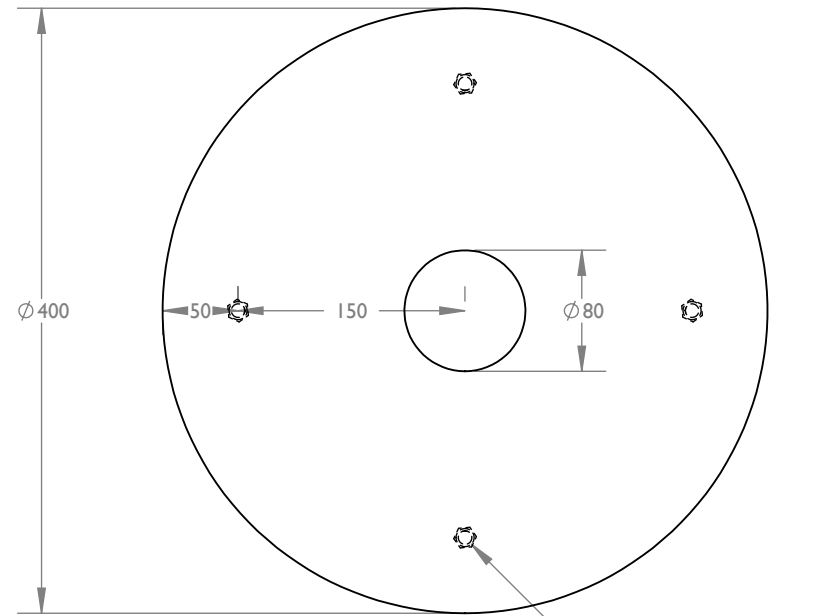

TOP VIEW

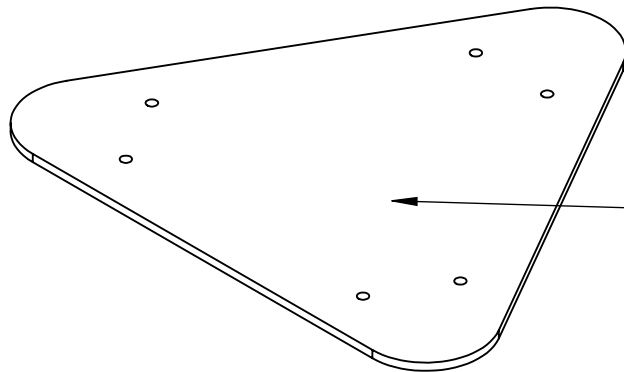

ISOMETRIC VIEW

THICKNESS 4MM

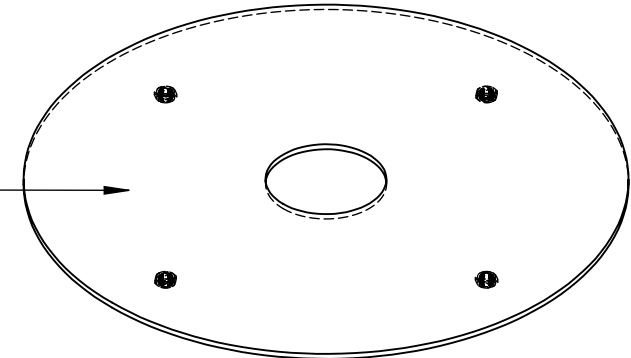

ISOMETRIC VIEW



MATIC OFFICE SYSTEM SDN BHD (547300-D)
 45E-2A, (TINGKAT 2) BANGUNAN BANGSARIA
 Jalan Maarof, Bangsar Baru, Bangsar
 59000 Kuala Lumpur
 t. +60322012045 f. +60322016024
 urf. www.matic.com.my

CLIENT'S CONFIRMATION & APPROVAL

COMPANY : DMX GROUP (MALAYSIA) SDN BHD

REPRESENTATIVE NAME : JAMES

DATE : 06.03.2023

SIGNATURE & COMPANY STAMP

PROJECT INFORMATION :

DRAWING NO:002/22/R0

FURNITURE TYPE : 120° CENTER
 CONNECTION BASE

DRAWING TYPE : DETAIL DRAWING

QUOTATION NO : M00888-22 R10

DRAWING INFORMATION :

DRAWN BY : FARAH

CHECKED BY: YIN QIAN

B.D. NAME : JEFT

PROJECT ID : MT23-P0022

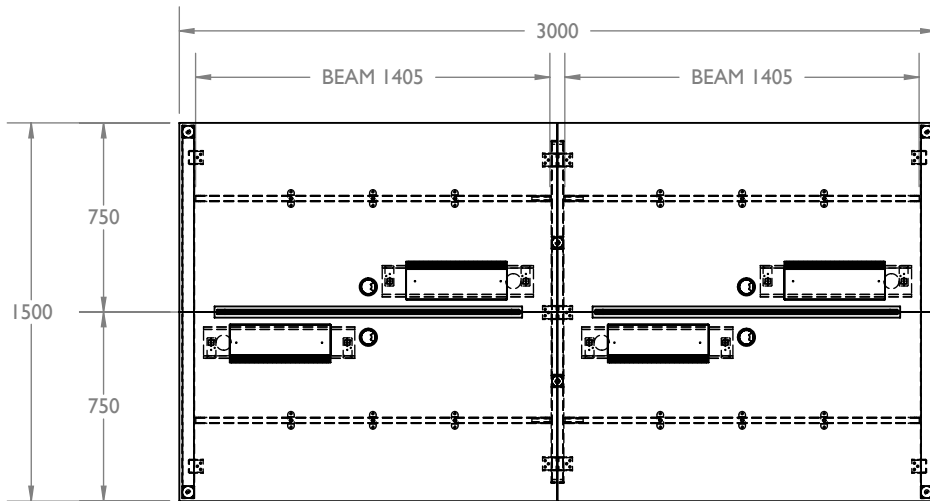

TOP VIEW

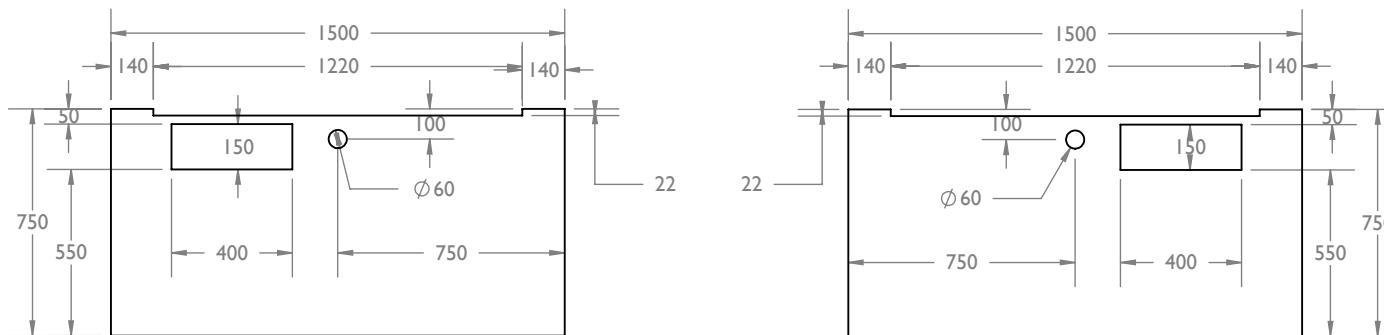

FLIPPER, GROMMET CUTOUT & ABS EDGING

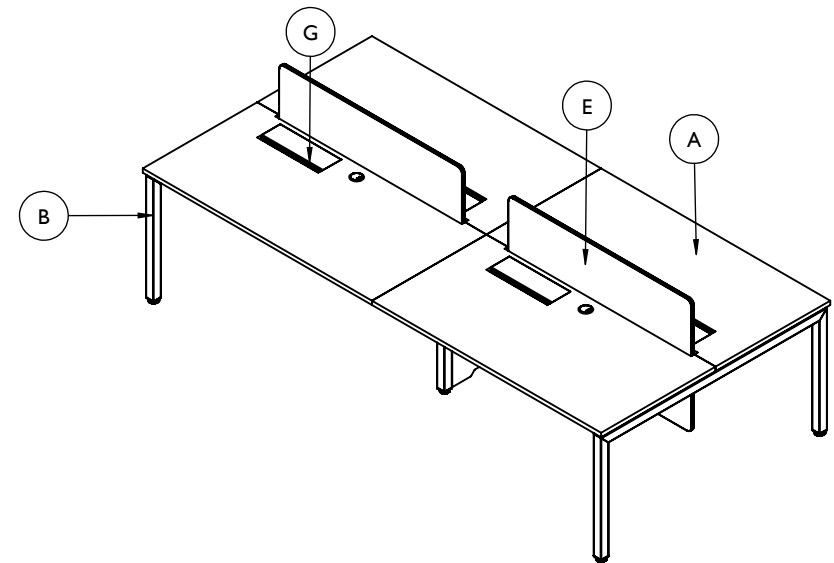

PRODUCTSPECIFICATION:		QTY:	FINISHING:
A	RECTANGULAR WORKTOP C/W HATCH HOLE & SCALLOP WITH ABS EDGING 1500L X 750D	4	ZAORA OAK 7315
B	EDGE METAL BASE CW 2 FRONT CONNECTOR 1480L X 725H	2	BLACK
C	CENTER BASE C/W 2 FRONT & 2 BACK CONNECTOR & CABLE PANEL 1350L X 725H	1	BLACK
D	METAL BEAM 1405L	4	BLACK
E	FRAMELESS TRANS 20 PANEL 1200L X 750H	2	GA910 SILVER
F	HALF HANGING PANEL BRACKET L/R	4	
G	WOODEN FLIPPER 180° OPENING C/W BRUSH & SOFT CLOSE 400L	4	ZAORA OAK 7315
H	WIRE TRAY 600L	4	BLACK
I	GROMMET HOLE WITH CAP 60D	4	BLACK
TOTAL SET: 1		PERSPECTIVE VIEW ALL DIMENSION IS IN MM	



MATIC OFFICE SYSTEM SDN BHD (547300-D)
45E-2A, (TINGKAT 2) BANGUNAN BANGSARIA
Jalan Maarof, Bangsar Baru, Bangsar
59000 Kuala Lumpur
t. +60322012045 f. +60322016024
urf. www.matic.com.my

CLIENT'S CONFIRMATION & APPROVAL

COMPANY : DMS GROUP (MALAYSIA) SDN BHD

REPRESENTATIVE NAME : JAMES

DATE : 06.03.2023

SIGNATURE & COMPANY STAMP

PROJECT INFORMATION :

DRAWING NO:003/22/R0

FURNITURE TYPE : EDGE W STATION
CLUSTER OF 4 F2F

DRAWING TYPE : ITEM 3

QUOTATION NO : M00888-22 R10

DRAWING INFORMATION :

DRAWN BY : FARAH

CHECKED BY: YIN QIAN/SEECAY

B.D. NAME : JEFT

PROJECT ID : MT23-P0022

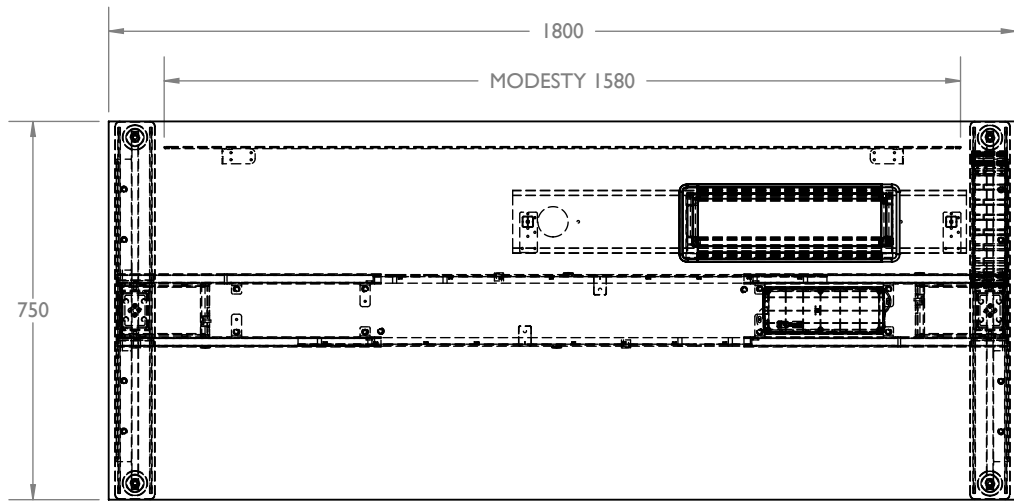

TOP VIEW

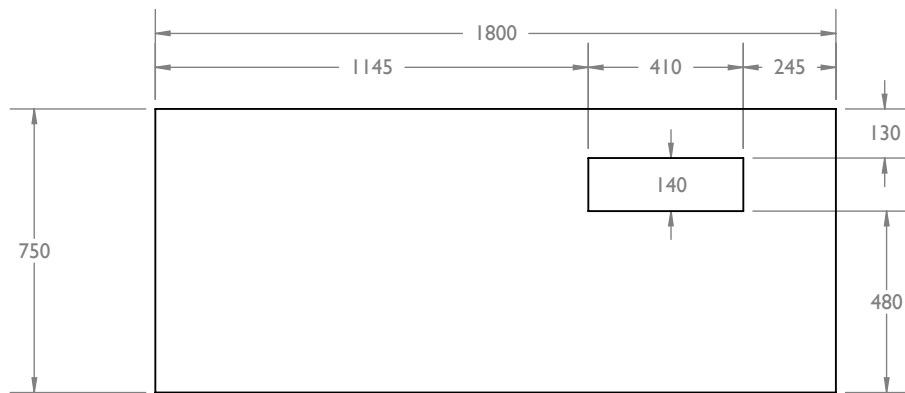

FLIPPER CUTOUT

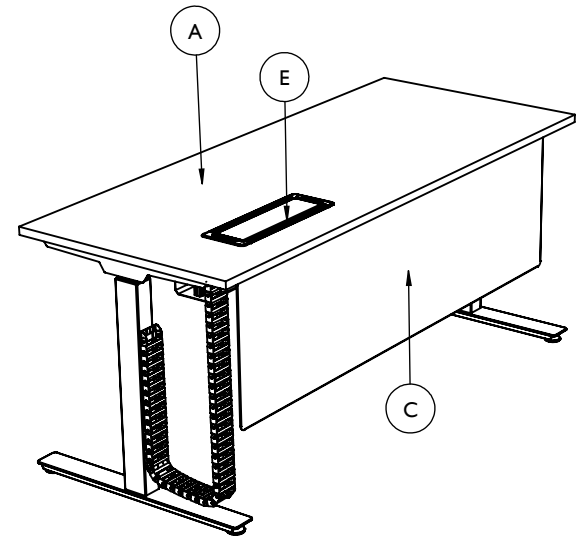

PRODUCT SPECIFICATION:		QTY:	FINISHING:
A	RECTANGULAR WORKTOP C/W HATCH HOLE 1800L X 750D	1	WHITE 601
B	RISE ADJUSTABLE METAL BASE STRUCTURE 725H (REFER QUO.FOR DETAILS)	1	BLACK
C	METAL MODESTY PLAIN (NO PERFORATED HOLES) 1580L X 450D	1	BLACK
D	MODESTY BRACKET L/R	2	
E	ALUMINIUM FLIPPER C/W SOFT CLOSE 400L	1	WHITE
F	WIRE TRAY 900L	1	BLACK
G			
H			
TOTAL SET: 1		PERSPECTIVE VIEW ALL DIMENSION IS IN MM	



MATIC OFFICE SYSTEM SDN BHD (547300-D)
 45E-2A, (TINGKAT 2) BANGUNAN BANGSARIA
 Jalan Maarof, Bangsar Baru, Bangsar
 59000 Kuala Lumpur
 t. +60322012045 f. +60322016024
 urf. www.matic.com.my

CLIENT'S CONFIRMATION & APPROVAL

COMPANY : DMX GROUP (MALAYSIA) SDN BHD

REPRESENTATIVE NAME : JAMES

DATE : 06.03.2023

SIGNATURE & COMPANY STAMP

PROJECT INFORMATION :

DRAWING NO:004/22/R0

FURNITURE TYPE : RISE RECTANGULAR TABLE

DRAWING TYPE : ITEM 4

QUOTATION NO : M00888-22 R10

DRAWING INFORMATION :

DRAWN BY : FARAH

CHECKED BY: YIN QIAN/SEECAY

B.D. NAME : JEFT

PROJECT ID : MT23-P0022



TOP VIEW

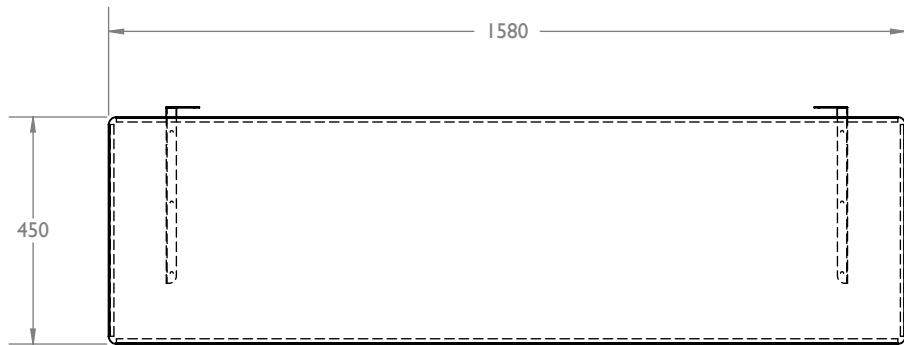

FRONT VIEW

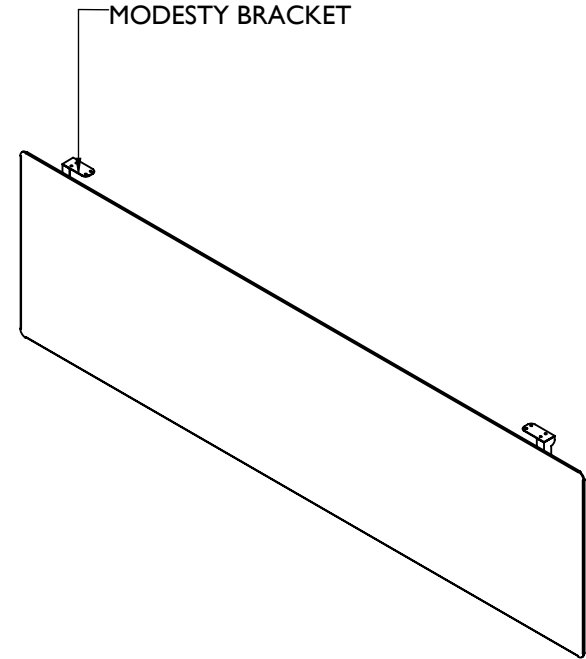

PRODUCT SPECIFICATION :		FINISHING:
A	METAL MODESTY PLAIN (NO PERFORATED HOLES) C/W 2 MODESTY BRACKET 1580L X 450D	BLACK
TOTAL SETS: 1		PERSPECTIVE VIEW ALL DIMENSION IS IN MM



MATIC OFFICE SYSTEM SDN BHD (547300-D)
 45E-2A, (TINGKAT 2) BANGUNAN BANGSARIA
 Jalan Maarof, Bangsar Baru, Bangsar
 59000 Kuala Lumpur
 t. +60322012045 f. +60322016024
 urf. www.matic.com.my

CLIENT'S CONFIRMATION & APPROVAL

COMPANY : DMX GROUP (MALAYSIA) SDN BHD

REPRESENTATIVE NAME : JAMES

DATE : 06.03.2023

SIGNATURE & COMPANY STAMP

PROJECT INFORMATION :

DRAWING NO:004/22/R0

FURNITURE TYPE : STEEL MODESTY

DRAWING TYPE : ITEM 4 - DETAILED

QUOTATION NO : M00888-22 R10

DRAWING INFORMATION :

DRAWN BY : FARAH

CHECKED BY: YIN QIAN/SEECAY

B.D. NAME : JEFT

PROJECT ID : MT23-P0022

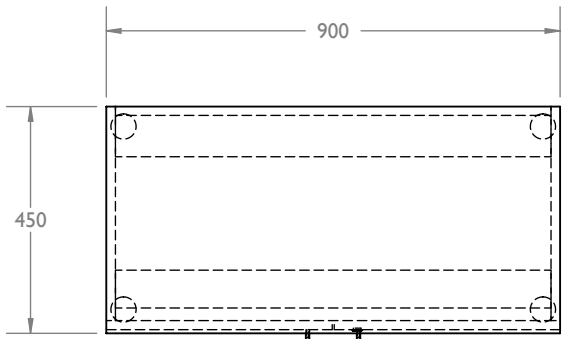

TOP VIEW

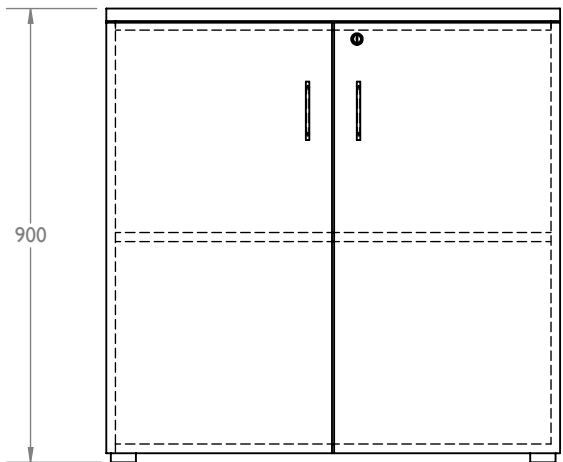

FRONT VIEW

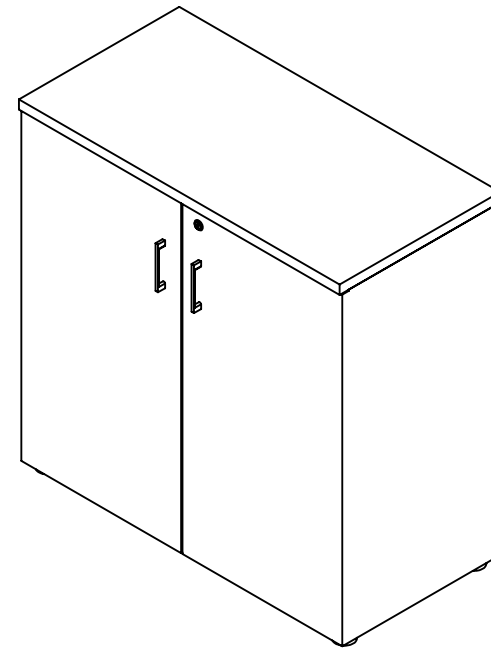

ISOMETRIC VIEW

PRODUCT SPECIFICATION :		FINISHING:
A	SWING DOOR LOW CABINET WITH STANDARD HANDLE 900L X 450D X 900H	FULL WHITE 60I
TOTAL SETS: I		PERSPECTIVE VIEW ALL DIMENSION IS IN MM



MATIC OFFICE SYSTEM SDN BHD (547300-D)
 45E-2A, (TINGKAT 2) BANGUNAN BANGSARIA
 Jalan Maarof, Bangsar Baru, Bangsar
 59000 Kuala Lumpur
 t. +60322012045 f. +60322016024
 urf. www.matic.com.my

CLIENT'S CONFIRMATION & APPROVAL

COMPANY : DMX GROUP (MALAYSIA) SDN BHD

REPRESENTATIVE NAME : JAMES

DATE : 06.03.2023

SIGNATURE & COMPANY STAMP

PROJECT INFORMATION :

DRAWING NO:005/22/R0

FURNITURE TYPE : PULITO SWING DOOR CABINET

DRAWING TYPE : ITEM 5

QUOTATION NO : M00888-22 R10

DRAWING INFORMATION :

DRAWN BY : FARAH

CHECKED BY: YIN QIAN/SEECAY

B.D. NAME : JEFT

PROJECT ID : MT23-P0022

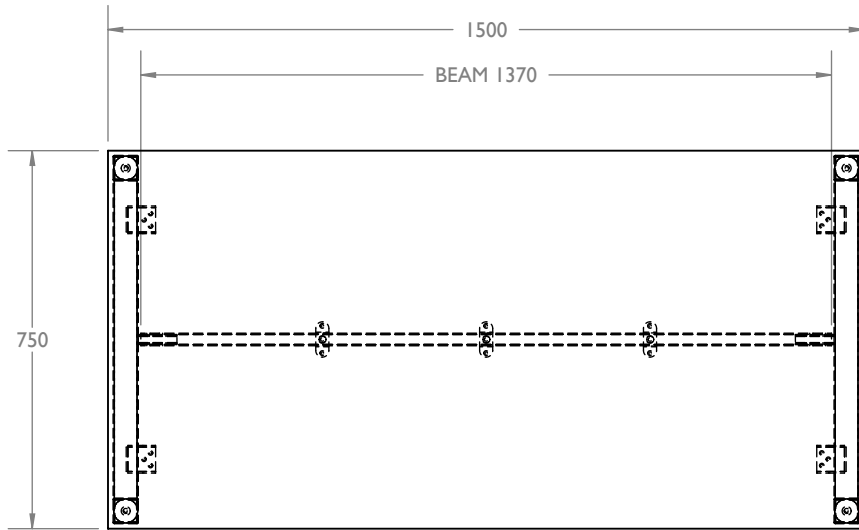

TOP VIEW

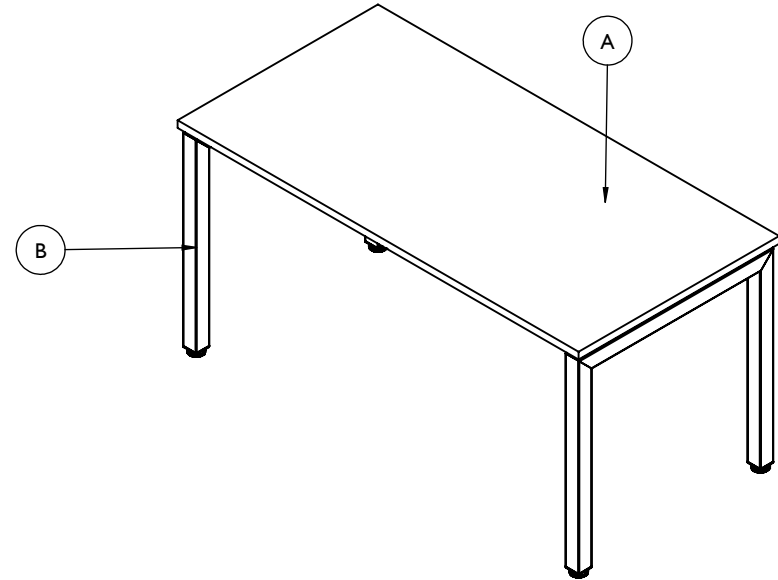

PRODUCTSPECIFICATION:		QTY:	FINISHING:
A	RECTANGULAR WORKTOP 1500L X 750D	1	ZAORA OAK 7315
B	EDGE METAL BASE I FRONT CONNECTOR 730L X 725H	2	BLACK
C	METAL BEAM 1370L	1	BLACK
D	JOINT BRACKET	2	
E			
F			
G			
H			
TOTAL SET: 1			PERSPECTIVE VIEW ALL DIMENSION IS IN MM



MATIC OFFICE SYSTEM SDN BHD (547300-D)
 45E-2A, (TINGKAT 2) BANGUNAN BANGSARIA
 Jalan Maarof, Bangsar Baru, Bangsar
 59000 Kuala Lumpur
 t. +60322012045 f. +60322016024
 urf. www.matic.com.my

CLIENT'S CONFIRMATION & APPROVAL

COMPANY : DMX GROUP (MALAYSIA) SDN BHD

REPRESENTATIVE NAME : JAMES

DATE : 06.03.2023

SIGNATURE & COMPANY STAMP

PROJECT INFORMATION :

DRAWING NO:006/22/R0

FURNITURE TYPE : EDGE W.STATION

DRAWING TYPE : ITEM 6

QUOTATION NO : M00888-22 R10

DRAWING INFORMATION :

DRAWN BY : FARAH

CHECKED BY: YIN QIAN/SEECAY

B.D. NAME : JEFT

PROJECT ID : MT23-P0022

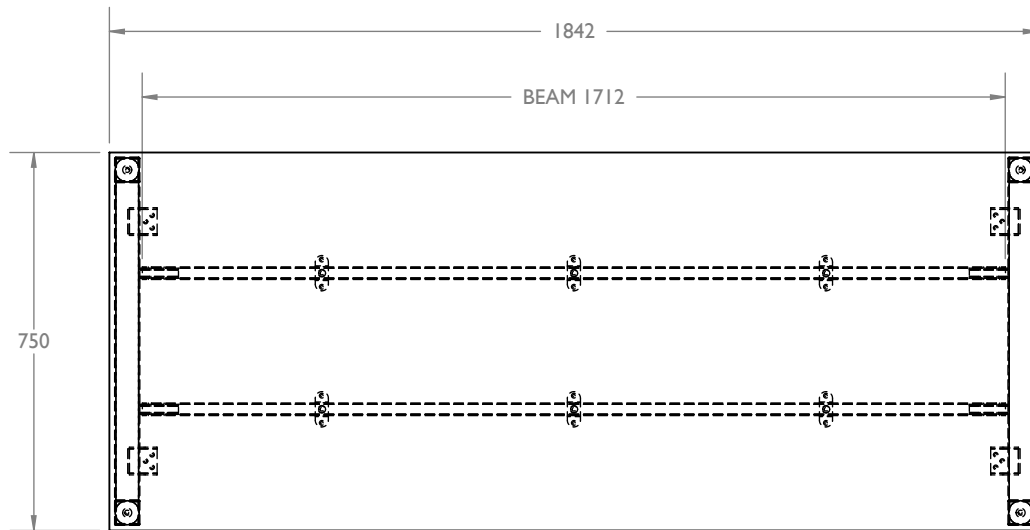

TOP VIEW

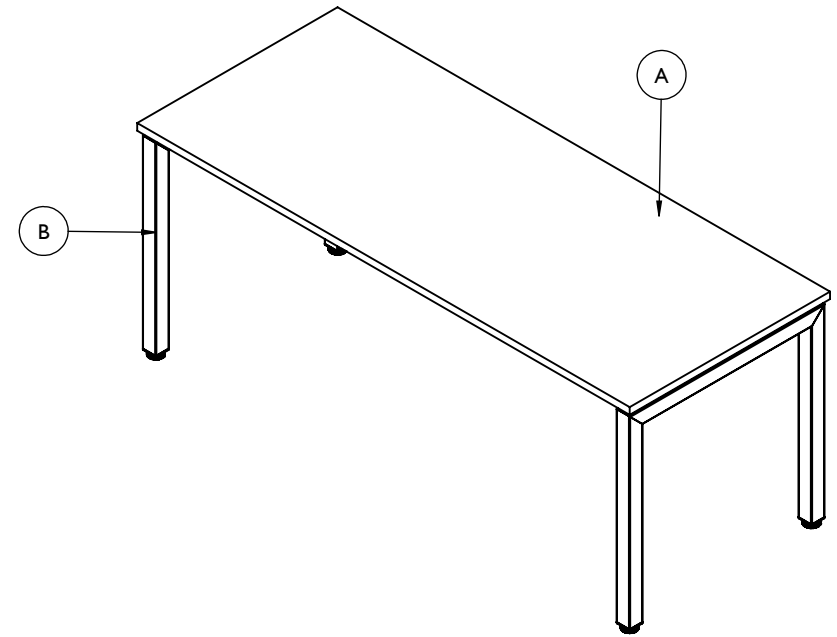

PRODUCTSPECIFICATION:		QTY:	FINISHING:
A	RECTANGULAR WORKTOP 1842L X 750D	1	ZAORA OAK 7315
B	EDGE METAL BASE 2 FRONT CONNECTOR 730L X 725H	2	BLACK
C	METAL BEAM 1712L	2	BLACK
D	JOINT BRACKET	2	
E			
F			
G			
H			
TOTAL SET: 2			PERSPECTIVE VIEW ALL DIMENSION IS IN MM



MATIC OFFICE SYSTEM SDN BHD (547300-D)
 45E-2A, (TINGKAT 2) BANGUNAN BANGSARIA
 Jalan Maarof, Bangsar Baru, Bangsar
 59000 Kuala Lumpur
 t. +60322012045 f. +60322016024
 urf. www.matic.com.my

CLIENT'S CONFIRMATION & APPROVAL

COMPANY : DMX GROUP (MALAYSIA) SDN BHD

REPRESENTATIVE NAME : JAMES

DATE : 06.03.2023

SIGNATURE & COMPANY STAMP

PROJECT INFORMATION :

DRAWING NO:007/22/R0

FURNITURE TYPE : EDGE W.STATION

DRAWING TYPE : ITEM 7

QUOTATION NO : M00888-22 R10

DRAWING INFORMATION :

DRAWN BY : FARAH

CHECKED BY: YIN QIAN/SEECAY

B.D. NAME : JEFT

PROJECT ID : MT23-P0022

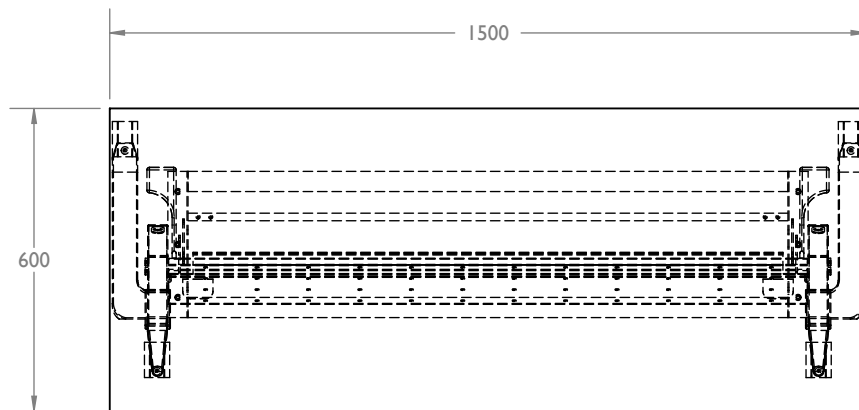
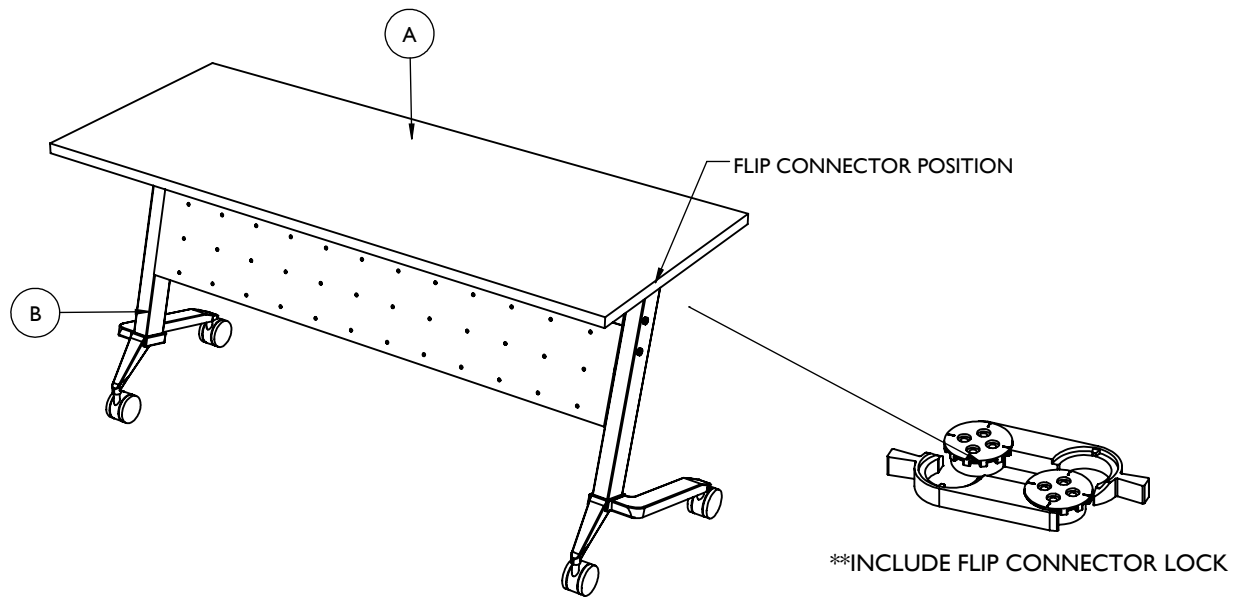

TOP VIEW

PRODUCTSPECIFICATION:		QTY:	FINISHING:
A	RECTANGULAR DESK 1500L X 600D	1	GRAPHITE 200
B	FLIP METAL BASE STRUCTURE C/W METAL MODESTY 1500L X 725H	1	BLACK
C	FLIP CONNECTOR LOCK	2	
D			
E			
F			
G			
H			
TOTAL SET: 6		PERSPECTIVE VIEW ALL DIMENSION IS IN MM	



MATIC OFFICE SYSTEM SDN BHD (547300-D)
 45E-2A, (TINGKAT 2) BANGUNAN BANGSARIA
 Jalan Maarof, Bangsar Baru, Bangsar
 59000 Kuala Lumpur
 t. +60322012045 f. +60322016024
 urf. www.matic.com.my

CLIENT'S CONFIRMATION & APPROVAL

COMPANY : DMX GROUP (MALAYSIA) SDN BHD

REPRESENTATIVE NAME : JAMES

DATE : 06.03.2022

SIGNATURE & COMPANY STAMP

PROJECT INFORMATION :

DRAWING NO:008/22/R0

FURNITURE TYPE : FLIP C/W MODESTY

DRAWING TYPE : ITEM 8

QUOTATION NO : M00888-22 R10

DRAWING INFORMATION :

DRAWN BY : FARAH

CHECKED BY: YIN QIAN/SEECAY

B.D. NAME : JEFT

PROJECT ID : MT23-P0022

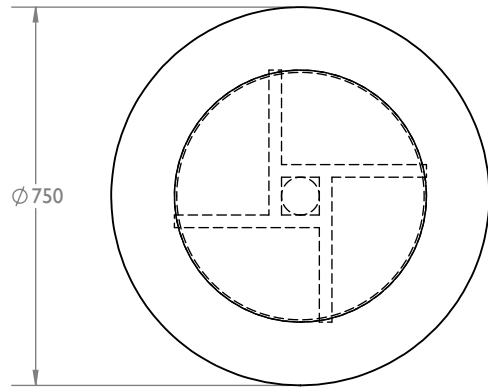

TOP VIEW

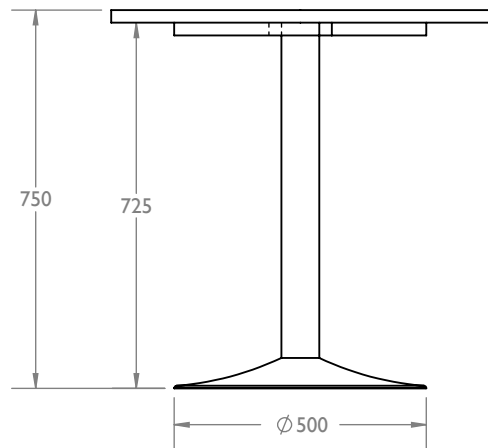

FRONT VIEW

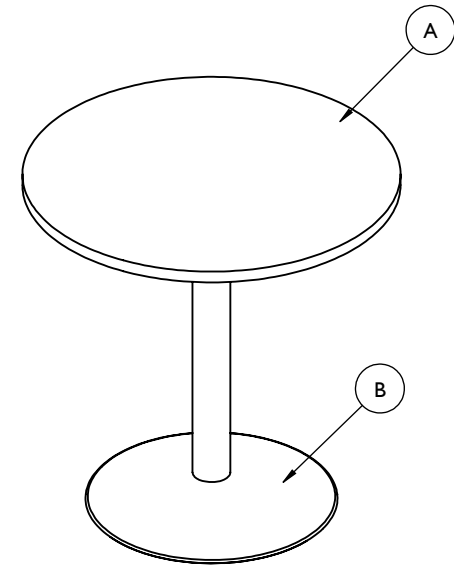

PRODUCT SPECIFICATION :		QTY:	FINISHING:
A	ROUND WORKTOP 750 ϕ	1	WHITE
B	DRUM METAL BASE 725H	1	BLACK
TOTAL SETS: 1			PERSPECTIVE VIEW ALL DIMENSION IS IN MM



MATIC OFFICE SYSTEM SDN BHD (547300-D)
 45E-2A, (TINGKAT 2) BANGUNAN BANGSARIA
 Jalan Maarof, Bangsar Baru, Bangsar
 59000 Kuala Lumpur
 t. +60322012045 f. +60322016024
 urf. www.matic.com.my

CLIENT'S CONFIRMATION & APPROVAL

COMPANY : DMX GROUP (MALAYSIA) SDN BHD

REPRESENTATIVE NAME : JAMES

DATE : 06.03.2023

SIGNATURE & COMPANY STAMP

PROJECT INFORMATION :

DRAWING NO:009/22/R0

FURNITURE TYPE : DRUM ROUND TABLE

DRAWING TYPE : ITEM 9

QUOTATION NO : M00888-22 R10

DRAWING INFORMATION :

DRAWN BY : FARAH

CHECKED BY: YIN QIAN/SEECAY

B.D. NAME : JEFT

PROJECT ID : MT23-P0022

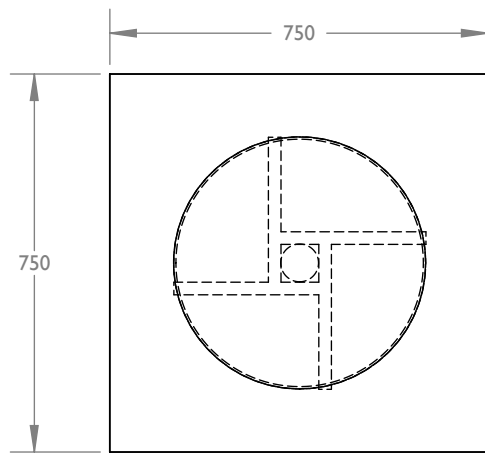
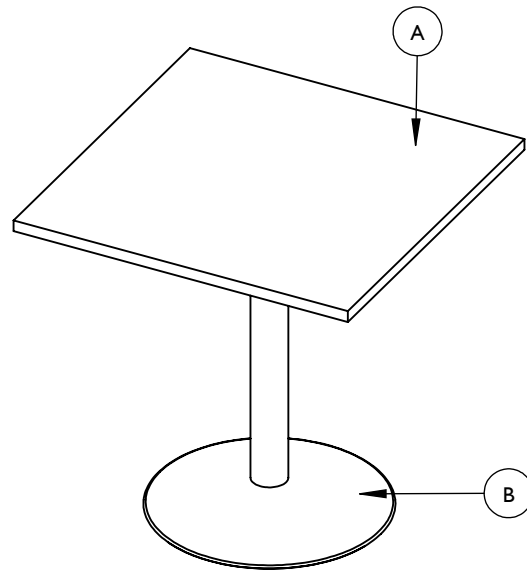

TOP VIEW

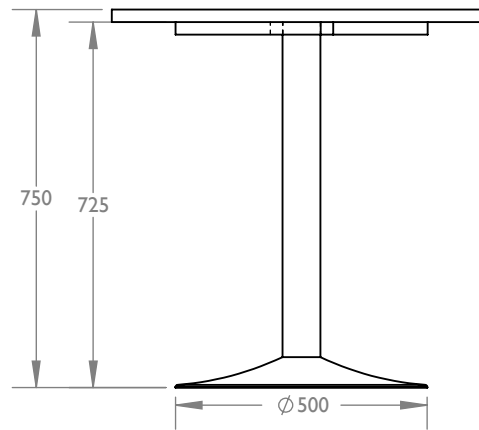

FRONT VIEW

PRODUCTSPECIFICATION:		QTY:	FINISHING:
A	RECTANGULAR WORKTOP 750L X 750D	1	WHITE 601
B	METAL BASE STRUCTURE 750L X 725H	1	BLACK
C			
D			
E			
F			
G			
H			
TOTAL SET: 3			PERSPECTIVE VIEW ALL DIMENSION IS IN MM



MATIC OFFICE SYSTEM SDN BHD (547300-D)
 45E-2A, (TINGKAT 2) BANGUNAN BANGSARIA
 Jalan Maarof, Bangsar Baru, Bangsar
 59000 Kuala Lumpur
 t. +60322012045 f. +60322016024
 urf. www.matic.com.my

CLIENT'S CONFIRMATION & APPROVAL

COMPANY : DMX GROUP (MALAYSIA) SDN BHD

REPRESENTATIVE NAME : JAMES

DATE : 06.03.2023

SIGNATURE & COMPANY STAMP

PROJECT INFORMATION :

DRAWING NO: 010/20/R0

FURNITURE TYPE : DRUM RECTANGULAR TABLE

DRAWING TYPE : ITEM 10

QUOTATION NO : M00888-22 R10

DRAWING INFORMATION :

DRAWN BY : FARAH

CHECKED BY: YIN QIAN/SECAY

B.D. NAME : JEFT

PROJECT ID : MT23-P0022

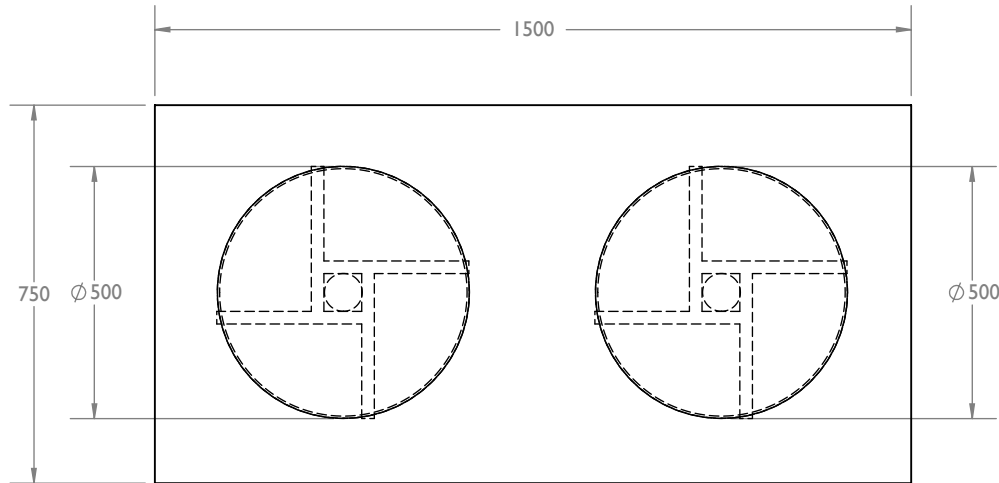

TOP VIEW

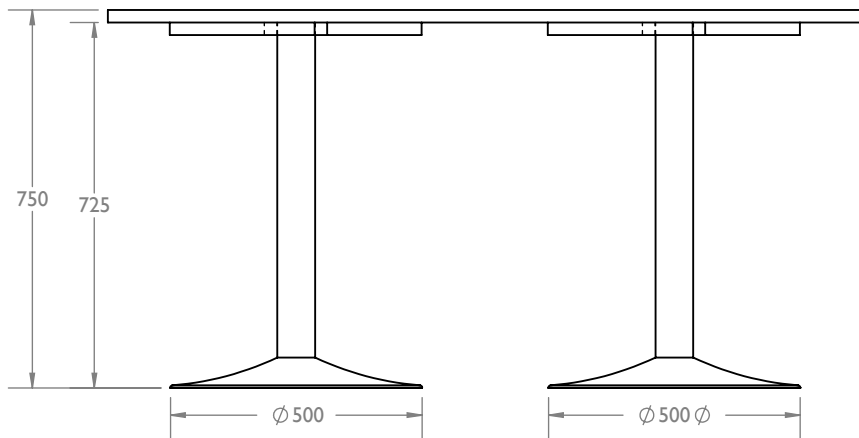

FRONT VIEW

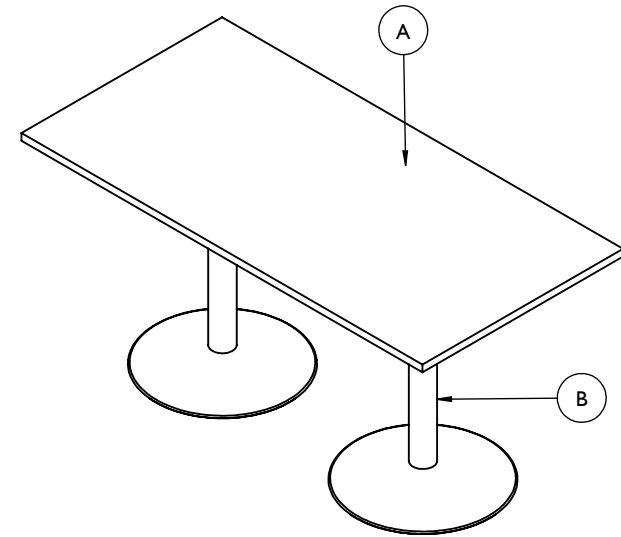

PRODUCTSPECIFICATION:		QTY:	FINISHING:
A	RECTANGULAR WORKTOP 1500L X 750D	1	WHITE 60I
B	METAL BASE STRUCTURE 750L X 725H	2	BLACK
C			
D			
E			
F			
G			
H			
TOTAL SET: 1			PERSPECTIVE VIEW ALL DIMENSION IS IN MM



MATIC OFFICE SYSTEM SDN BHD (547300-D)
 45E-2A, (TINGKAT 2) BANGUNAN BANGSARIA
 Jalan Maarof, Bangsar Baru, Bangsar
 59000 Kuala Lumpur
 t. +60322012045 f. +60322016024
 urf. www.matic.com.my

CLIENT'S CONFIRMATION & APPROVAL

COMPANY : DMX GROUP (MALAYSIA) SDN BHD

REPRESENTATIVE NAME : JAMES

DATE : 06.03.2023

SIGNATURE & COMPANY STAMP

PROJECT INFORMATION :

DRAWING NO:011/22/R0

FURNITURE TYPE : DRUM RECTANGULAR TABLE

DRAWING TYPE : ITEM 11

QUOTATION NO : M00888-22 R10

DRAWING INFORMATION :

DRAWN BY : FARAH

CHECKED BY: YIN QIAN/SEECAY

B.D. NAME : JEFT

PROJECT ID : MT23-P0022