

TOP VIEW

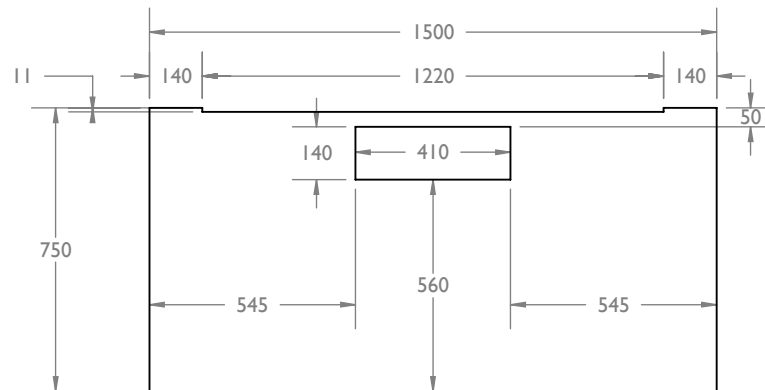

FLIPPER CUTOUT & ABS EDGING

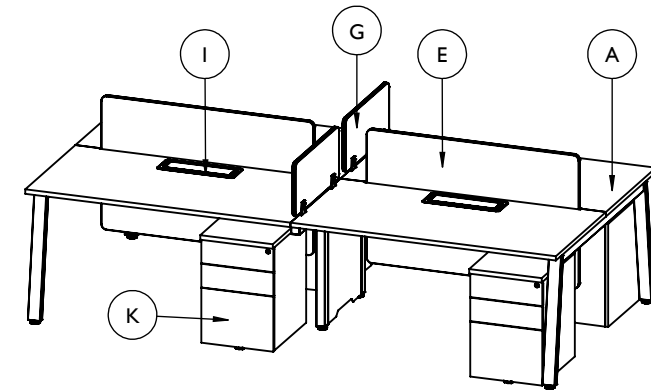

PRODUCTSPECIFICATION:		QTY:	FINISHING:
A	RECTANGULAR WORKTOP C/W HATCH HOLE & ABS EDGING 1500L X 750D	4	CELTIC ASH 0595
B	ORI M METAL BASE C/W 2 FRONT CONNECTOR 1480L X 725H	2	WHITE
C	CENTER BASE C/W 2 FRONT & 2 BACK CONNECTOR & CABLE PANEL 1350L X 725H	1	WHITE
D	METAL BEAM I395L	4	WHITE
E	FRAMELESS TRANS 20 PANEL 1200L X 750H	2	GA910 SILVER
F	DOUBLE SIDE SCREEN PANEL BRACKET L/R	4	WHITE
G	FRAMELESS TRANS 20 SIDE PANEL 650L X 300H	2	GA910 SILVER
H	PANEL HOLDER	4	WHITE
I	ALUMINIUM FLIPPER C/W SOFT CLOSE 400L	4	BLACK
J	WIRE TRAY 900L	4	BLACK
K	2D IF MOBILE PEDESTAL WITH CHAMFER HANDLE 410L X 450D X 620H	4	FULL BLACK 400
TOTAL SET: 2			PERSPECTIVE VIEW ALL DIMENSION IS IN MM



MATIC OFFICE SYSTEM SDN BHD (547300-D)
45E-2A, (TINGKAT 2) BANGUNAN BANGSARIA
Jalan Maarof, Bangsar Baru, Bangsar
59000 Kuala Lumpur
t. +60322012045 f. +60322016024
urf. www.matic.com.my

CLIENT'S CONFIRMATION & APPROVAL

COMPANY : DMX GROUP (MALAYSIA) SDN BHD

REPRESENTATIVE NAME : JAMES

DATE : 06.06.2023

SIGNATURE & COMPANY STAMP

PROJECT INFORMATION :

DRAWING NO:001/22/R0

FURNITURE TYPE : ORI M W.STATION F2F

DRAWING TYPE : ITEM 1 - GF

QUOTATION NO : M00234-23 R8

DRAWING INFORMATION :

DRAWN BY : FARAH

CHECKED BY: YIN QIAN

B.D. NAME : JEFT

PROJECT ID : MT23-P0110

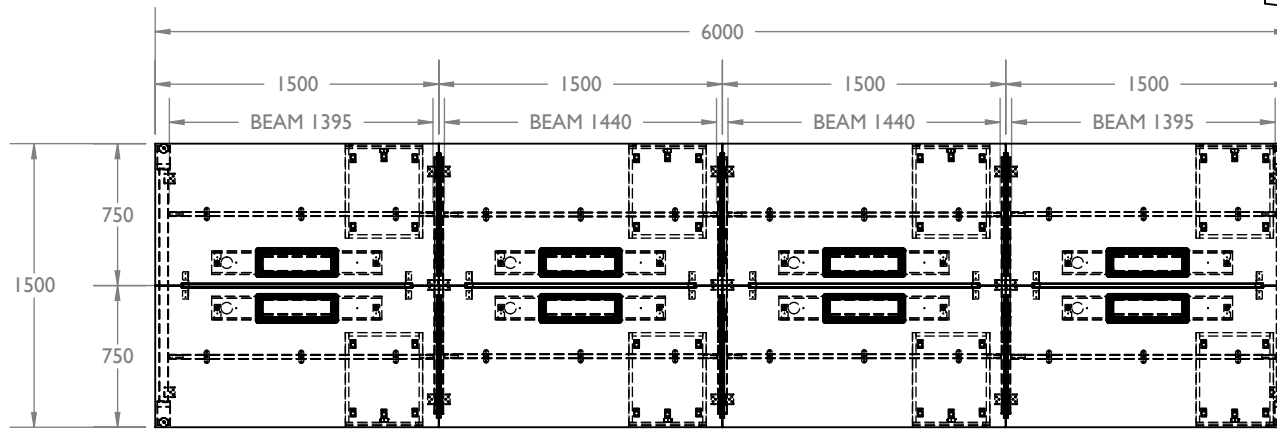

TOP VIEW

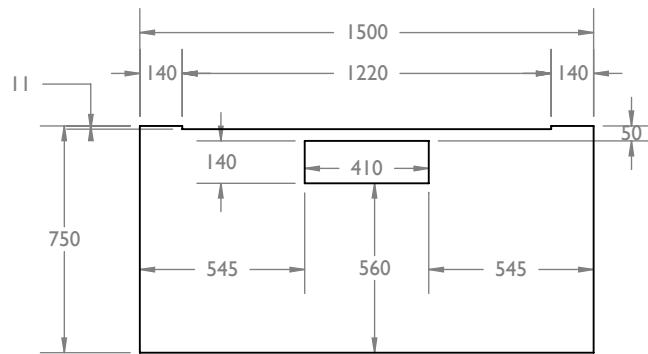

FLIPPER CUTOUT & ABS EDGING

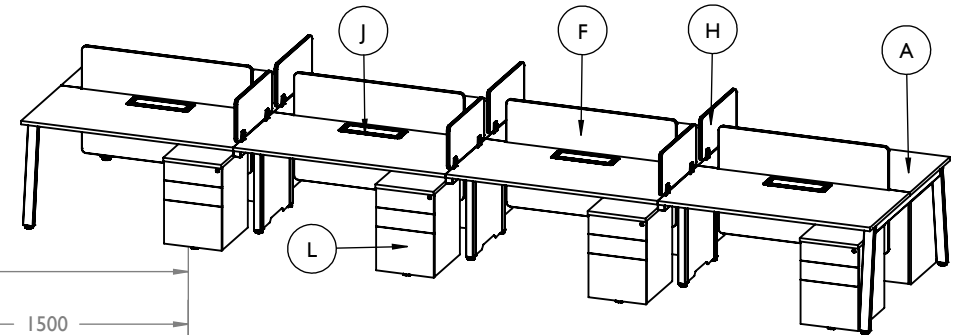

PRODUCTSPECIFICATION:		QTY:	FINISHING:
A	RECTANGULAR WORKTOP C/W HATCH HOLE & ABS EDGING 1500L X 750D	8	CELTIC ASH 0595
B	ORI M METAL BASE C/W 2 FRONT CONNECTOR 1480L X 725H	2	WHITE
C	CENTER BASE C/W 2 FRONT & 2 BACK CONNECTOR & CABLE PANEL 1350L X 725H	3	WHITE
D	METAL BEAM 1395L	4	WHITE
E	METAL BEAM 1440L	4	WHITE
F	FRAMELESS TRANS 20 PANEL 1200L X 750H	4	GA910 SILVER
G	DOUBLE SIDE SCREEN PANEL BRACKET L/R	8	WHITE
H	FRAMELESS TRANS 20 SIDE PANEL 650L X 300H	6	GA910 SILVER
I	PANEL HOLDER	12	WHITE
J	ALUMINIUM FLIPPER C/W SOFT CLOSE 400L	8	BLACK
K	WIRE TRAY 900L	8	BLACK
L	2D IF MOBILE PEDESTAL WITH CHAMFER HANDLE 410L X 450D X 620H	8	FULL BLACK 400
TOTAL SET: 1		PERSPECTIVE VIEW ALL DIMENSION IS IN MM	



MATIC OFFICE SYSTEM SDN BHD (547300-D)
 45E-2A, (TINGKAT 2) BANGUNAN BANGSARIA
 Jalan Maarof, Bangsar Baru, Bangsar
 59000 Kuala Lumpur
 t. +60322012045 f. +60322016024
 urf. www.matic.com.my

CLIENT'S CONFIRMATION & APPROVAL

COMPANY : DMX GROUP (MALAYSIA) SDN BHD

REPRESENTATIVE NAME : JAMES

DATE : 06.06.2023

SIGNATURE & COMPANY STAMP

PROJECT INFORMATION :

DRAWING NO:002/22/R0

FURNITURE TYPE :ORI M W.STATION F2F

DRAWING TYPE : ITEM 2 - GF

QUOTATION NO : M00234-23 R8

DRAWING INFORMATION :

DRAWN BY : FARAH

CHECKED BY: YIN QIAN

B.D. NAME : JEFT

PROJECT ID : MT23-P0110

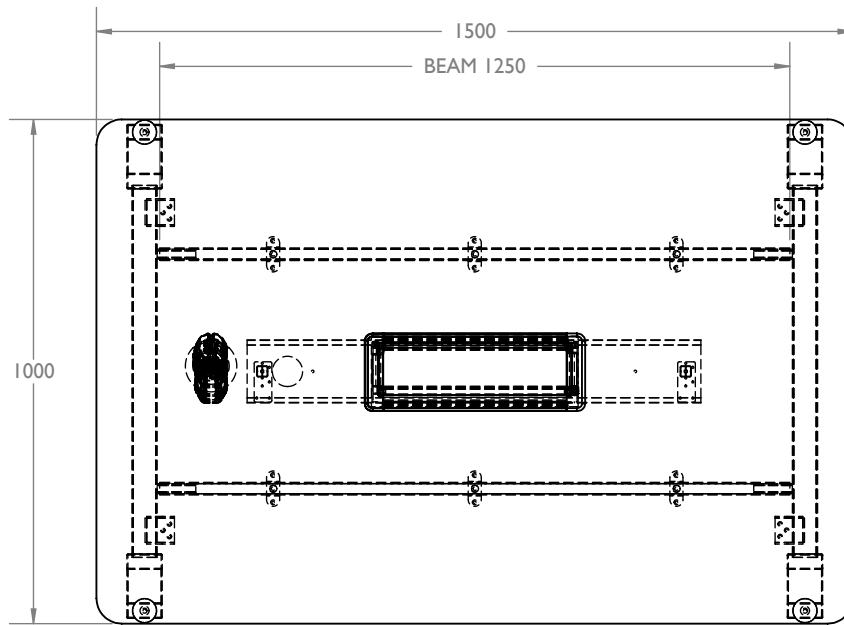

TOP VIEW

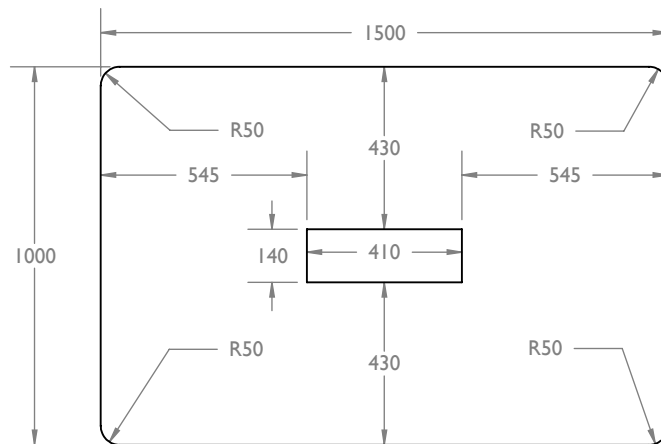

FLIPPER CUTOUT & ROUNDED CORNER

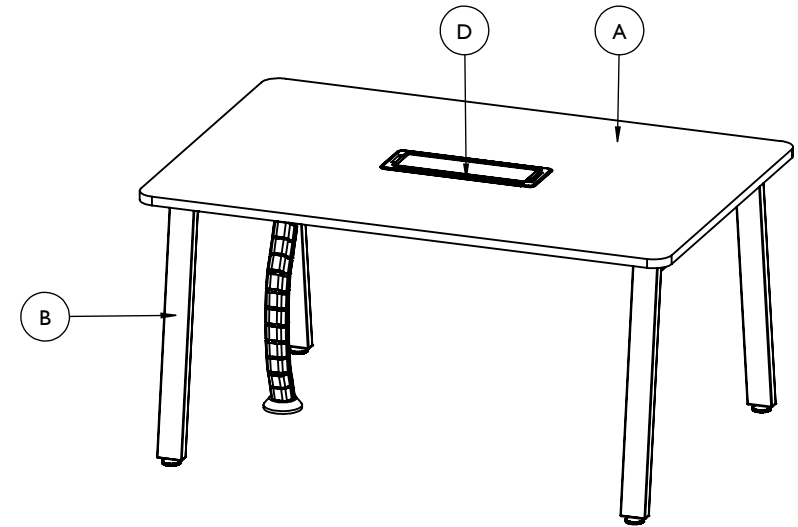

PRODUCTSPECIFICATION:		QTY:	FINISHING:
A	RECTANGULAR WORKTOP C/W HATCH HOLE & ROUNDED CORNER (R50) 1500L X 1000D	1	GRAPHITE
B	ORI M METAL BASE C/W 2 FRONT CONNECTOR 980L X 725H	2	BLACK
C	METAL BEAM 1250L	2	BLACK
D	ALUMINIUM FLIPPER C/W SOFT CLOSE 400L	1	BLACK
E	WIRE TRAY 900L	1	BLACK
F	PVC SNAKE CABLE	1	
G			
H			
TOTAL SET: 1			PERSPECTIVE VIEW ALL DIMENSION IS IN MM



MATIC OFFICE SYSTEM SDN BHD (547300-D)
45E-2A, (TINGKAT 2) BANGUNAN BANGSARIA
Jalan Maarof, Bangsar Baru, Bangsar
59000 Kuala Lumpur
t. +60322012045 f. +60322016024
urf. www.matic.com.my

CLIENT'S CONFIRMATION & APPROVAL

COMPANY : DMX GROUP (MALAYSIA) SDN BHD

REPRESENTATIVE NAME : JAMES

DATE : 06.06.2023

SIGNATURE & COMPANY STAMP

PROJECT INFORMATION :

DRAWING NO:003/22/R0

FURNITURE TYPE : ORI M MEETING TABLE

DRAWING TYPE : ITEM 3 - GF

QUOTATION NO : M00234-23 R8

DRAWING INFORMATION :

DRAWN BY : FARAH

CHECKED BY: YIN QIAN

B.D. NAME : JEFT

PROJECT ID : MT23-P0110

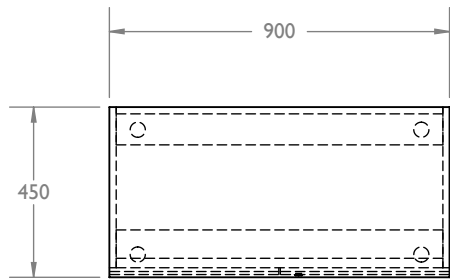

TOP VIEW

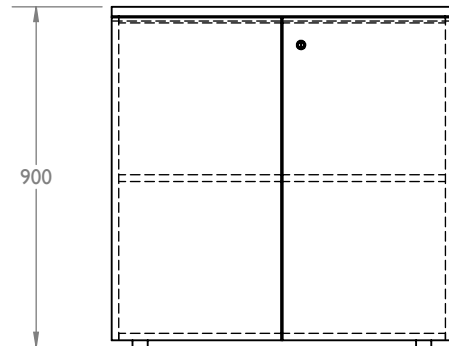

TOP VIEW

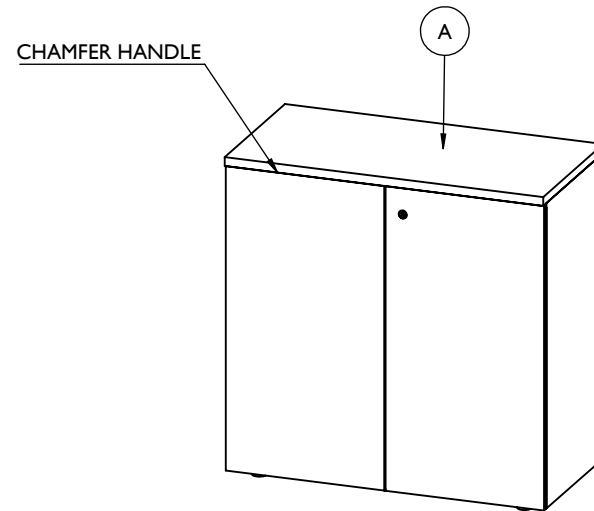

PRODUCT SPECIFICATION :		QTY:	FINISHING:
A	SWING DOOR LOW CABINET C/W CHAMFER HANDLE 900L X 450D X 900H (MFC)	1	FULL GRAPHITE
TOTAL SETS: 1			PERSPECTIVE VIEW ALL DIMENSION IS IN MM



MATIC OFFICE SYSTEM SDN BHD (547300-D)
 45E-2A, (TINGKAT 2) BANGUNAN BANGSARIA
 Jalan Maarof, Bangsar Baru, Bangsar
 59000 Kuala Lumpur
 t. +60322012045 f. +60322016024
 urf. www.matic.com.my

CLIENT'S CONFIRMATION & APPROVAL

COMPANY : DMX GROUP (MALAYSIA) SDN BHD

REPRESENTATIVE NAME : JAMES

DATE : 06.06.2023

SIGNATURE & COMPANY STAMP

PROJECT INFORMATION :

DRAWING NO:004/22/R0

FURNITURE TYPE : LOW CABINET

DRAWING TYPE : ITEM 4 - GF

QUOTATION NO : M00234-23 R8

DRAWING INFORMATION :

DRAWN BY : FARAH

CHECKED BY: YIN QIAN

B.D. NAME : JEFT

PROJECT ID : MT23-P0110

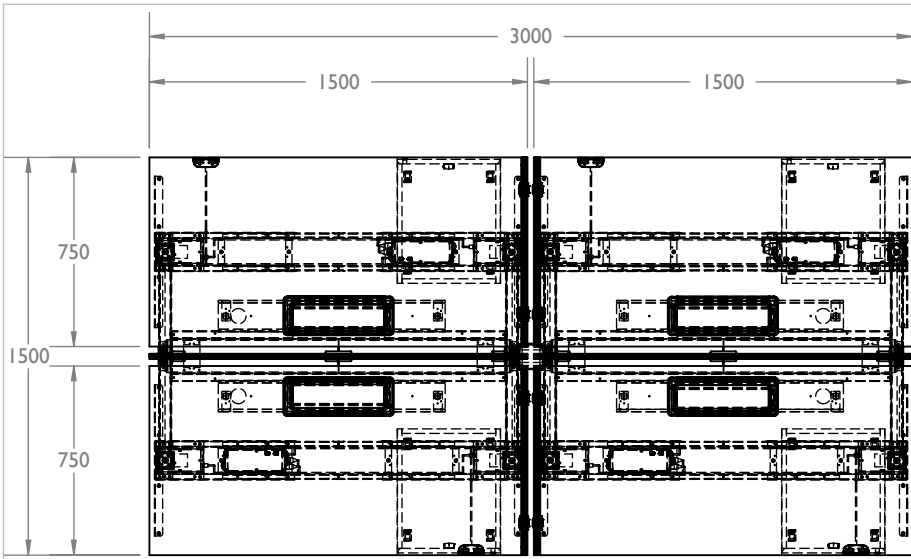

TOP VIEW

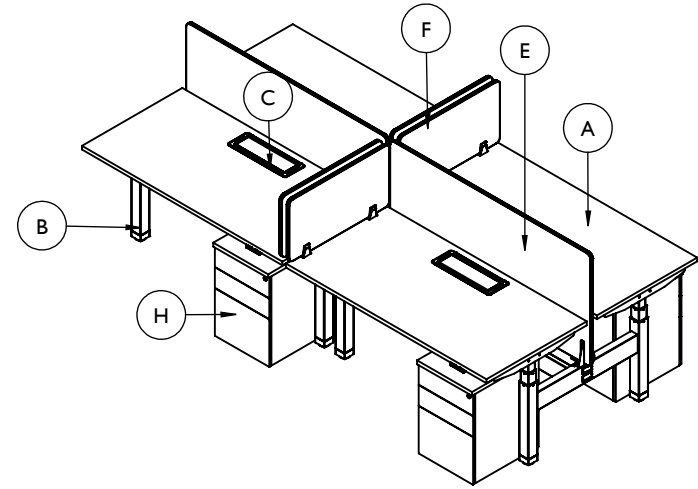

PRODUCTSPECIFICATION:		QTY:	FINISHING:
A	RECTANGULAR WORKTOP C/W HATCH HOLE 1500L X 750D	4	CELTIC ASH 0595
B	RISE ADJUSTABLE METAL BASE STRUCTURE 725H (REFER QUO.FOR DETAILS)	1	BLACK
C	ALUMINIUM FLIPPER C/W SOFT CLOSE 400L	4	BLACK
D	WIRE TRAY 900L	4	BLACK
E	FRAMELESS TRANS 20 PANEL 1500L X 725H	2	GA910 SILVER
F	FRAMELESS TRANS 20 SIDE PANEL 750L X 400H	4	GA910 SILVER
G	PANEL HOLDER	8	WHITE
H	2D IF MOBILE PEDESTAL WITH CHAMFER HANDLE 410L X 450D X 620H	4	FULL CELTIC ASH 0595
I			
TOTAL SET: 2		PERSPECTIVE VIEW ALL DIMENSION IS IN MM	

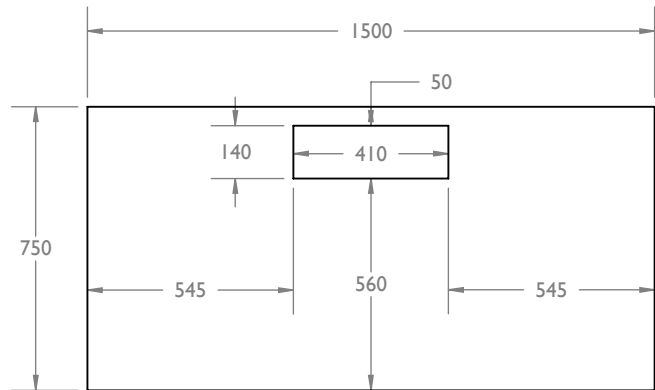

FLIPPER CUTOUT

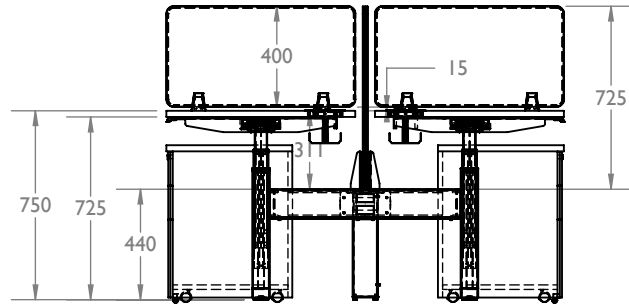

SIDE VIEW



MATIC OFFICE SYSTEM SDN BHD (547300-D)
 45E-2A, (TINGKAT 2) BANGUNAN BANGSARIA
 Jalan Maarof, Bangsar Baru, Bangsar
 59000 Kuala Lumpur
 t. +60322012045 f. +60322016024
 urf. www.matic.com.my

CLIENT'S CONFIRMATION & APPROVAL

COMPANY : DMX GROUP (MALAYSIA) SDN BHD

REPRESENTATIVE NAME : JAMES

DATE : 06.06.2023

SIGNATURE & COMPANY STAMP

PROJECT INFORMATION :

DRAWING NO:001/22/R0

FURNITURE TYPE : RISE W.STATION

DRAWING TYPE : ITEM 1 - MEZZANINE

QUOTATION NO : M00234-23 R8

DRAWING INFORMATION :

DRAWN BY : FARAH

CHECKED BY: YIN QIAN

B.D. NAME : JEFT

PROJECT ID : MT23-P0110

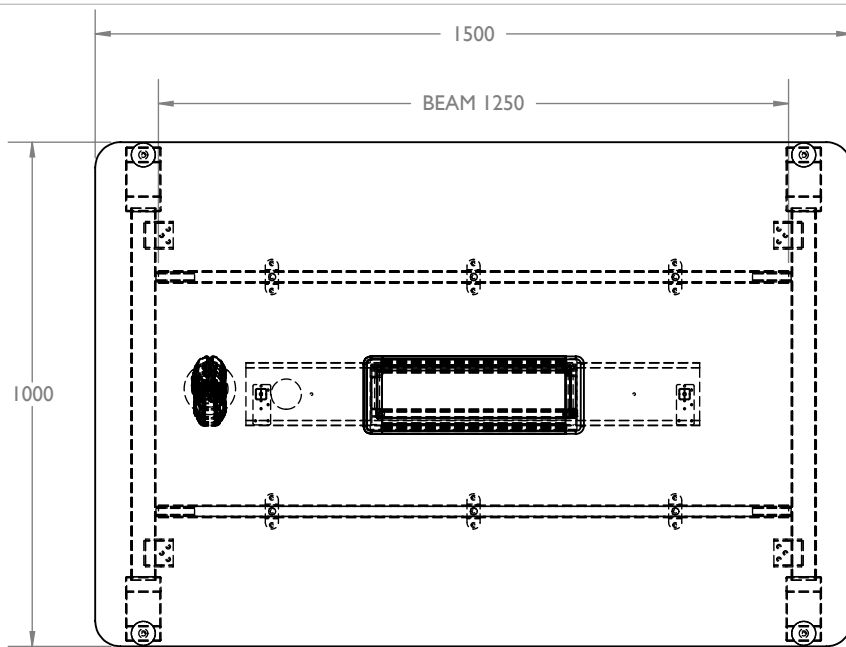

TOP VIEW

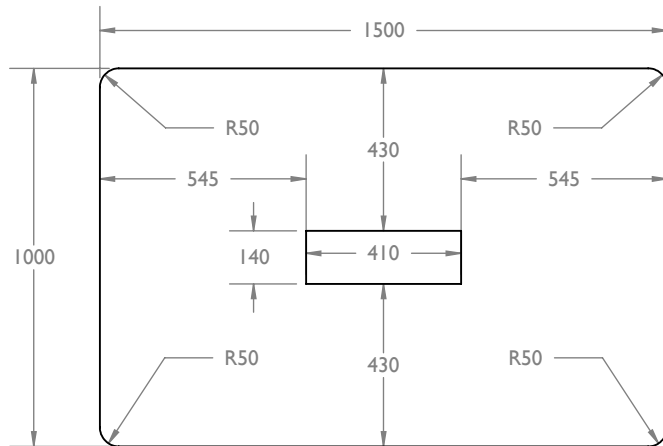

FLIPPER CUTOUT & ROUNDED CORNER

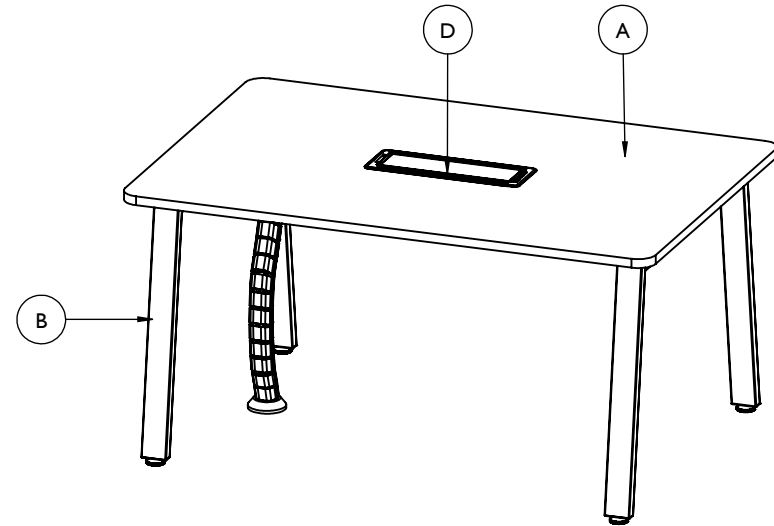

PRODUCTSPECIFICATION:		QTY:	FINISHING:
A	RECTANGULAR WORKTOP C/W HATCH HOLE & ROUNDED CORNER (R50) 1500L X 1000D	1	GRAPHITE
B	ORI M METAL BASE C/W 2 FRONT CONNECTOR 980L X 725H	2	BLACK
C	METAL BEAM 1250L	2	BLACK
D	ALUMINIUM FLIPPER C/W SOFT CLOSE 400L	1	BLACK
E	WIRE TRAY 900L	1	BLACK
F	PVC SNAKE CABLE	1	
G			
H			
TOTAL SET: 1			PERSPECTIVE VIEW ALL DIMENSION IS IN MM



MATIC OFFICE SYSTEM SDN BHD (547300-D)
45E-2A, (TINGKAT 2) BANGUNAN BANGSARIA
Jalan Maarof, Bangsar Baru, Bangsar
59000 Kuala Lumpur
t. +60322012045 f. +60322016024
urf. www.matic.com.my

CLIENT'S CONFIRMATION & APPROVAL

COMPANY : DMX GROUP (MALAYSIA) SDN BHD

REPRESENTATIVE NAME : JAMES

DATE : 06.06.2023

SIGNATURE & COMPANY STAMP

PROJECT INFORMATION :

DRAWING NO:002/22/R0

FURNITURE TYPE : ORI M MEETING TABLE

DRAWING TYPE : ITEM 2 - MEZZANINE

QUOTATION NO : M00234-23 R8

DRAWING INFORMATION :

DRAWN BY : FARAH

CHECKED BY: YIN QIAN

B.D. NAME : JEFT

PROJECT ID : MT23-P0110

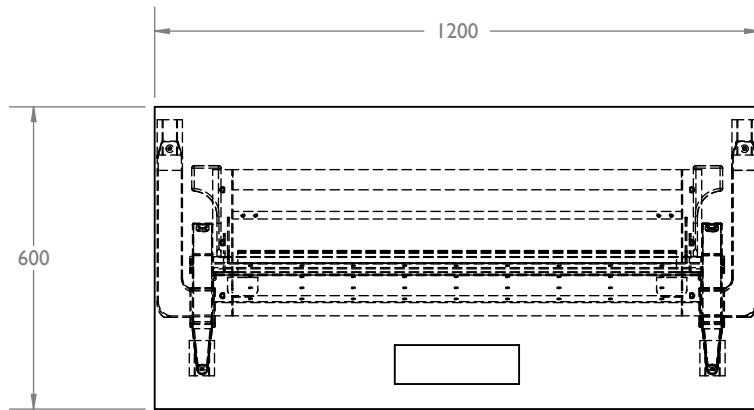

TOP VIEW

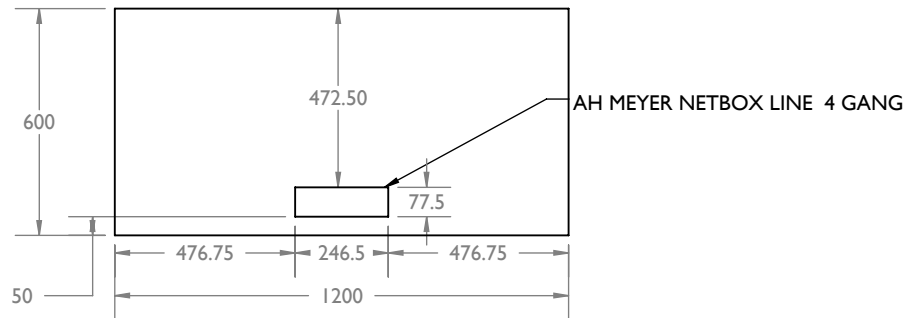

AH MEYER CUTOUT

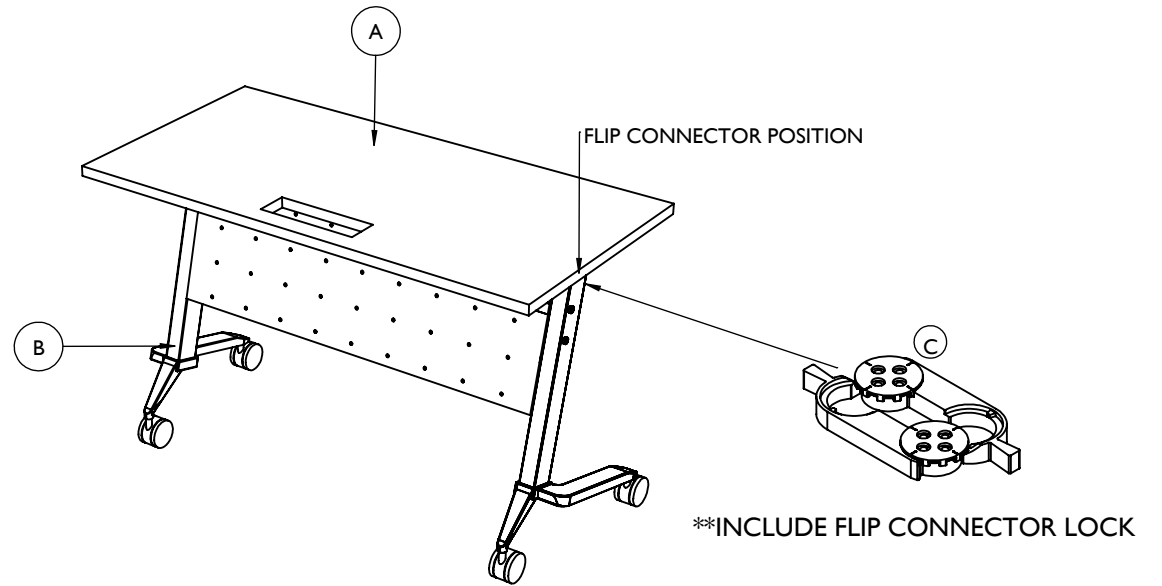

PRODUCTSPECIFICATION:		QTY:	FINISHING:
A	RECTANGULAR WORKTOP C/W HATCH HOLE 1200L X 600D	1	GRAPHITE
B	METAL BASE STRUCTURE C/W METAL MODESTY 1200L X 725H	1	BLACK
C	FLIP CONNECTOR LOCK	2	
D			
E			
F			
G			
H			
TOTAL SET: 8			PERSPECTIVE VIEW ALL DIMENSION IS IN MM



MATIC OFFICE SYSTEM SDN BHD (547300-D)
 45E-2A, (TINGKAT 2) BANGUNAN BANGSARIA
 Jalan Maarof, Bangsar Baru, Bangsar
 59000 Kuala Lumpur
 t. +60322012045 f. +60322016024
 urf. www.matic.com.my

CLIENT'S CONFIRMATION & APPROVAL

COMPANY : DMX GROUP (MALAYSIA) SDN BHD

REPRESENTATIVE NAME : JAMES

DATE : 06.06.2023

SIGNATURE & COMPANY STAMP

PROJECT INFORMATION :

DRAWING NO:003/22/R0

FURNITURE TYPE : FLIP MEETING TABLE

DRAWING TYPE : ITEM 3 - MEZZANINE

QUOTATION NO : M00234-23 R8

DRAWING INFORMATION :

DRAWN BY : FARAH

CHECKED BY: YIN QIAN

B.D. NAME : JEFT

PROJECT ID : MT23-P0110

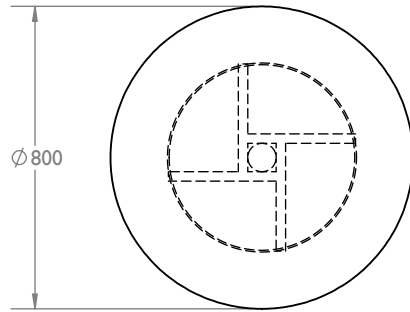

TOP VIEW

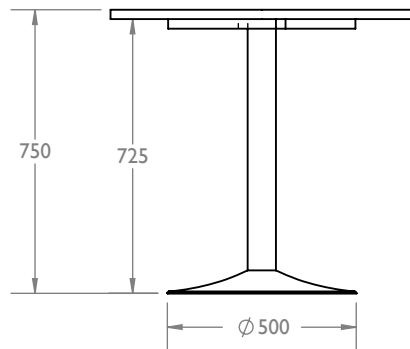

FRONT VIEW

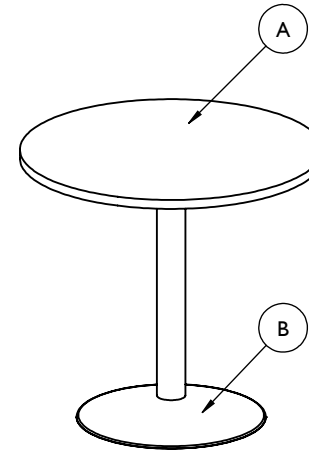

PRODUCT SPECIFICATION :		QTY:	FINISHING:
A	ROUND WORKTOP 800D	1	WHITE
B	DRUM METAL BASE 800D X 725H	1	BLACK
TOTAL SETS: 2			PERSPECTIVE VIEW ALL DIMENSION IS IN MM



MATIC OFFICE SYSTEM SDN BHD (547300-D)
 45E-2A, (TINGKAT 2) BANGUNAN BANGSARIA
 Jalan Maarof, Bangsar Baru, Bangsar
 59000 Kuala Lumpur
 t. +60322012045 f. +60322016024
 urf. www.matic.com.my

CLIENT'S CONFIRMATION & APPROVAL

COMPANY : DMX GROUP (MALAYSIA) SDN BHD

REPRESENTATIVE NAME : JAMES

DATE : 06.06.2023

SIGNATURE & COMPANY STAMP

PROJECT INFORMATION :

DRAWING NO:005/22/R0

FURNITURE TYPE : DRUM ROUND TABLE

DRAWING TYPE : ITEM 5 - MEZZANINE

QUOTATION NO : M00234-23 R8

DRAWING INFORMATION :

DRAWN BY : FARAH

CHECKED BY: YIN QIAN

B.D. NAME : JEFT

PROJECT ID : MT23-P0110

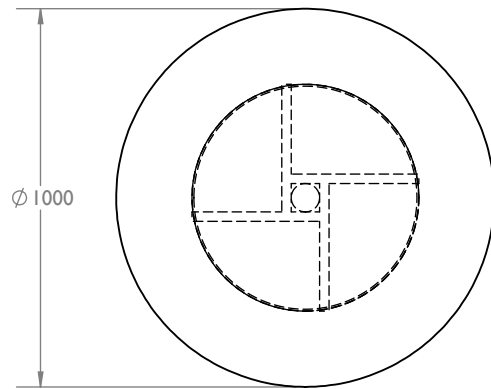

TOP VIEW

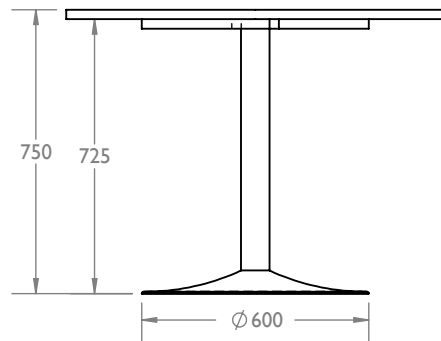

FRONT VIEW

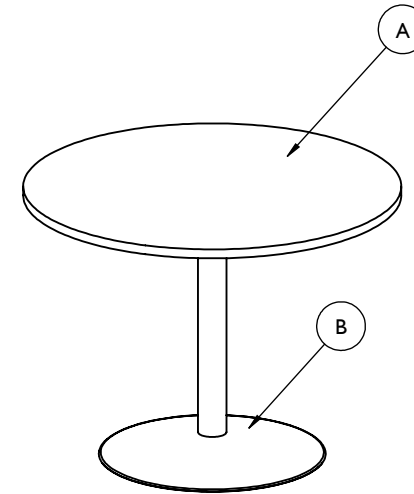

PRODUCT SPECIFICATION :		QTY:	FINISHING:
A	ROUND WORKTOP 1000D	1	WHITE
B	DRUM METAL BASE 1000D X 725H	1	BLACK
TOTAL SETS: 3			PERSPECTIVE VIEW ALL DIMENSION IS IN MM



MATIC OFFICE SYSTEM SDN BHD (547300-D)
 45E-2A, (TINGKAT 2) BANGUNAN BANGSARIA
 Jalan Maarof, Bangsar Baru, Bangsar
 59000 Kuala Lumpur
 t. +60322012045 f. +60322016024
 urf. www.matic.com.my

CLIENT'S CONFIRMATION & APPROVAL

COMPANY : DMX GROUP (MALAYSIA) SDN BHD

REPRESENTATIVE NAME : JAMES

DATE : 06.06.2023

SIGNATURE & COMPANY STAMP

PROJECT INFORMATION :

DRAWING NO:006/22/R0

FURNITURE TYPE : DRUM ROUND TABLE

DRAWING TYPE : ITEM 6 - MEZZANINE

QUOTATION NO : M00234-23 R8

DRAWING INFORMATION :

DRAWN BY : FARAH

CHECKED BY: YIN QIAN

B.D. NAME : JEFT

PROJECT ID : MT23-P0110

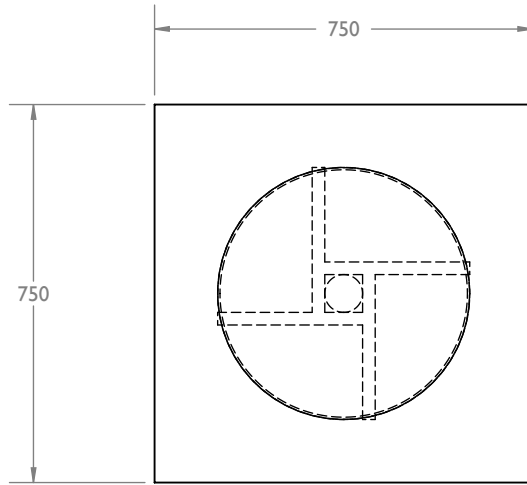

TOP VIEW

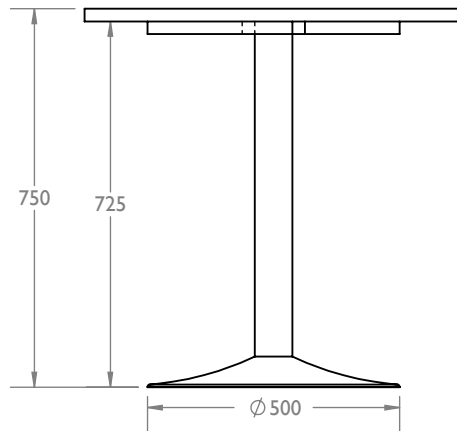

FRONT VIEW

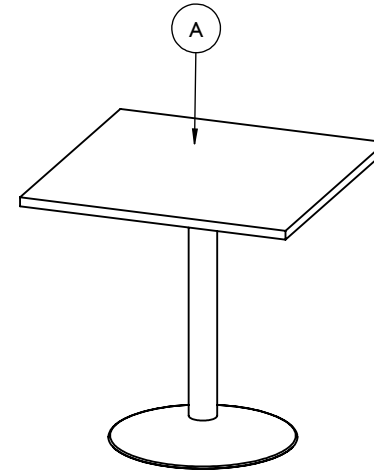

PRODUCT SPECIFICATION :		QTY:	FINISHING:
A	SQUARE WORKTOP 750L X 750D	1	WHITE
B	DRUM METAL BASE 750D X 725H	1	BLACK
TOTAL SETS: 4			PERSPECTIVE VIEW ALL DIMENSION IS IN MM



MATIC OFFICE SYSTEM SDN BHD (547300-D)
 45E-2A, (TINGKAT 2) BANGUNAN BANGSARIA
 Jalan Maarof, Bangsar Baru, Bangsar
 59000 Kuala Lumpur
 t. +60322012045 f. +60322016024
 urf. www.matic.com.my

CLIENT'S CONFIRMATION & APPROVAL

COMPANY : DMX GROUP (MALAYSIA) SDN BHD

REPRESENTATIVE NAME : JAMES

DATE : 06.06.2023

SIGNATURE & COMPANY STAMP

PROJECT INFORMATION :

DRAWING NO:007/22/R0

FURNITURE TYPE : PANTRY AXIS TABLE

DRAWING TYPE : ITEM 7 - MEZZANINE

QUOTATION NO : M00234-23 R8

DRAWING INFORMATION :

DRAWN BY : FARAH

CHECKED BY: YIN QIAN

B.D. NAME : JEFT

PROJECT ID : MT23-P0110

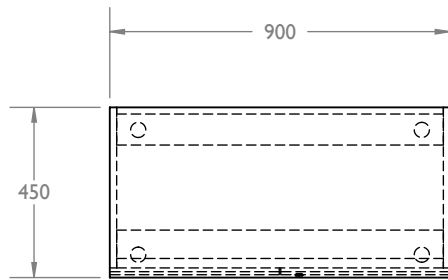

TOP VIEW

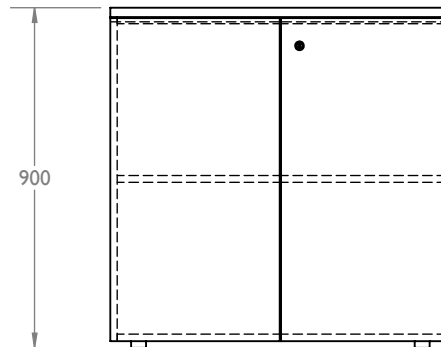

FRONT VIEW

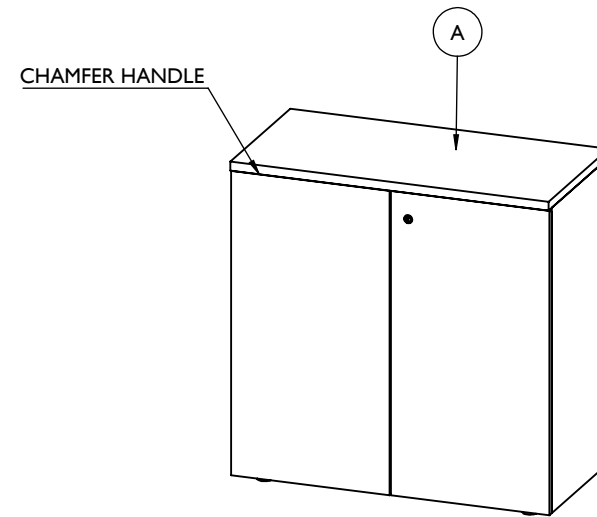

PRODUCT SPECIFICATION :		QTY:	FINISHING:
A	SWING DOOR LOW CABINET C/W CHAMFER HANDLE 900L X 450D X 900H (MFC)	1	FULL WHITE
TOTAL SETS: 2			PERSPECTIVE VIEW ALL DIMENSION IS IN MM



MATIC OFFICE SYSTEM SDN BHD (547300-D)
 45E-2A, (TINGKAT 2) BANGUNAN BANGSARIA
 Jalan Maarof, Bangsar Baru, Bangsar
 59000 Kuala Lumpur
 t. +60322012045 f. +60322016024
 urf. www.matic.com.my

CLIENT'S CONFIRMATION & APPROVAL

COMPANY : DMX GROUP (MALAYSIA) SDN BHD

REPRESENTATIVE NAME : JAMES

DATE : 06.06.2023

SIGNATURE & COMPANY STAMP

PROJECT INFORMATION :

DRAWING NO:008/22/R0

FURNITURE TYPE : LOW CABINET

DRAWING TYPE : ITEM 8 - MEZZANINE

QUOTATION NO : M00234-23 R8

DRAWING INFORMATION :

DRAWN BY : FARAH

CHECKED BY: YIN QIAN

B.D. NAME : JEFT

PROJECT ID : MT23-P0110

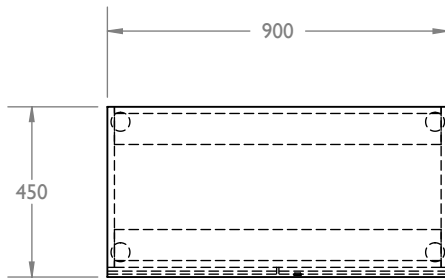

TOP VIEW

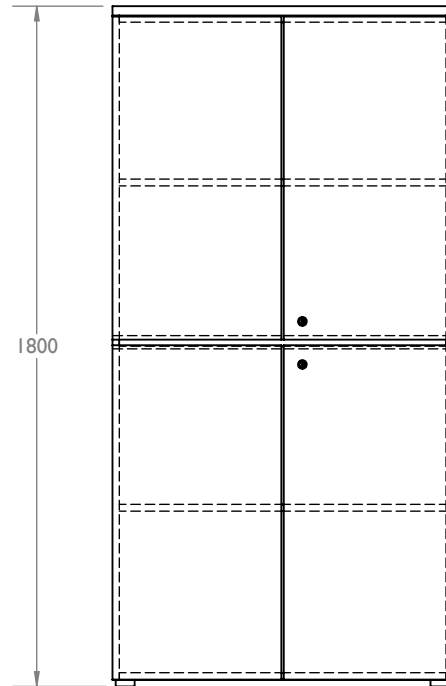

FRONT VIEW

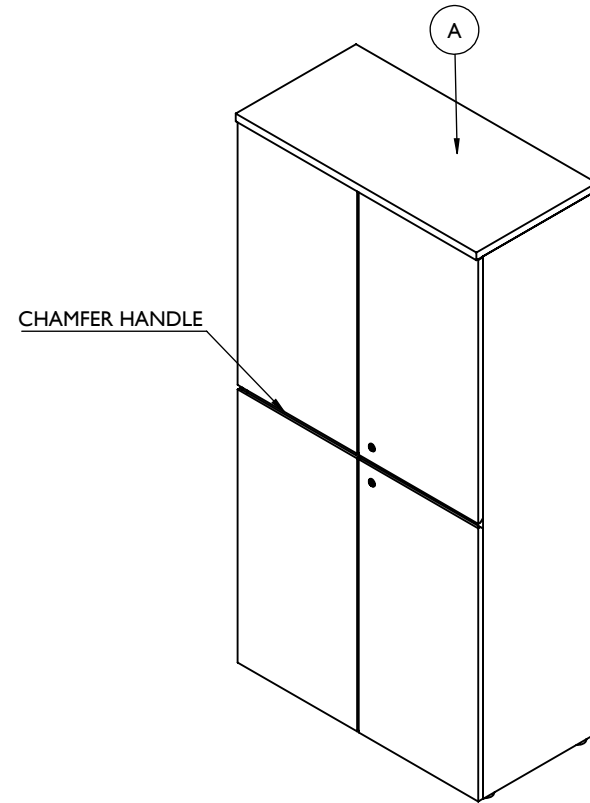

PRODUCT SPECIFICATION :		QTY:	FINISHING:
A	2 TIER SWING DOOR HIGH CABINET C/W CHAMFER HANDLE 900L X 450D X 1800H (MFC)	1	FULL WHITE
TOTAL SETS: 2			PERSPECTIVE VIEW ALL DIMENSION IS IN MM



MATIC OFFICE SYSTEM SDN BHD (547300-D)
 45E-2A, (TINGKAT 2) BANGUNAN BANGSARIA
 Jalan Maarof, Bangsar Baru, Bangsar
 59000 Kuala Lumpur
 t. +60322012045 f. +60322016024
 urf. www.matic.com.my

CLIENT'S CONFIRMATION & APPROVAL

COMPANY : DMX GROUP (MALAYSIA) SDN BHD

REPRESENTATIVE NAME : JAMES

DATE :06.06.2023

SIGNATURE & COMPANY STAMP

PROJECT INFORMATION :

DRAWING NO:009/22/R0

FURNITURE TYPE : 2 TIER HIGH CABINET

DRAWING TYPE : ITEM 9 - MEZZANINE

QUOTATION NO : M00234-23 R8

DRAWING INFORMATION :

DRAWN BY : FARAH

CHECKED BY: YIN QIAN

B.D. NAME : JEFT

PROJECT ID : MT23-P0110

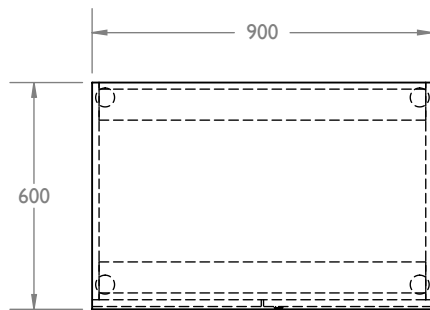

TOP VIEW

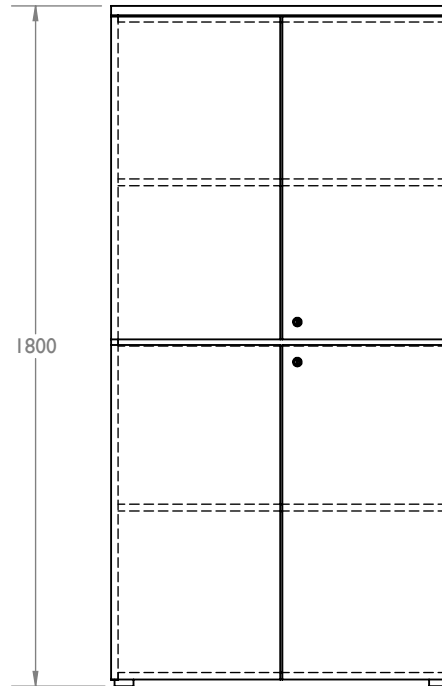

FRONT VIEW

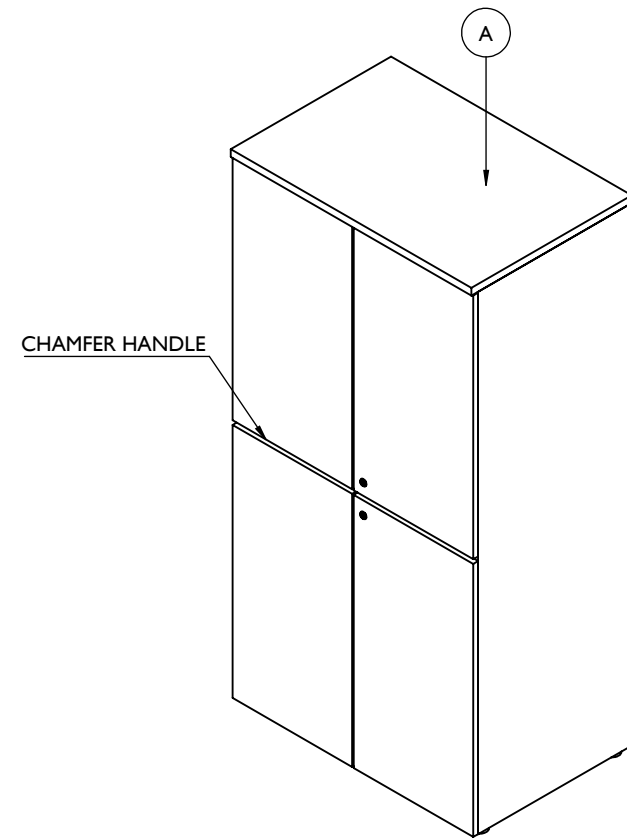

PRODUCT SPECIFICATION :		QTY:	FINISHING:
A	2 TIER SWING DOOR HIGH CABINET C/W CHAMFER HANDLE 900L X 600D X 1800H (MFC)	1	FULL WHITE
TOTAL SETS: 7			PERSPECTIVE VIEW ALL DIMENSION IS IN MM



MATIC OFFICE SYSTEM SDN BHD (547300-D)
 45E-2A, (TINGKAT 2) BANGUNAN BANGSARIA
 Jalan Maarof, Bangsar Baru, Bangsar
 59000 Kuala Lumpur
 t. +60322012045 f. +60322016024
 urf. www.matic.com.my

CLIENT'S CONFIRMATION & APPROVAL

COMPANY : DMX GROUP (MALAYSIA) SDN BHD

REPRESENTATIVE NAME : JAMES

DATE : 06.06.2023

SIGNATURE & COMPANY STAMP

PROJECT INFORMATION :

DRAWING NO:010/22/R0

FURNITURE TYPE : 2 TIER HIGH CABINET

DRAWING TYPE : ITEM 10 - MEZZANINE

QUOTATION NO : M00234-23 R8

DRAWING INFORMATION :

DRAWN BY : FARAH

CHECKED BY: YIN QIAN

B.D. NAME : JEFT

PROJECT ID : MT23-P0110

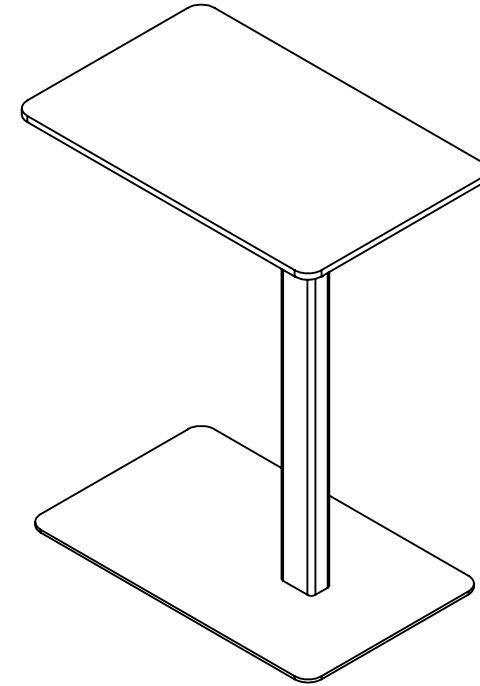
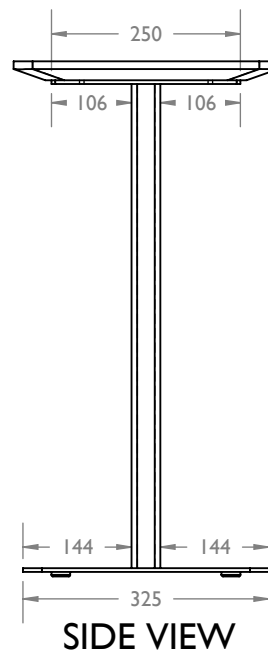
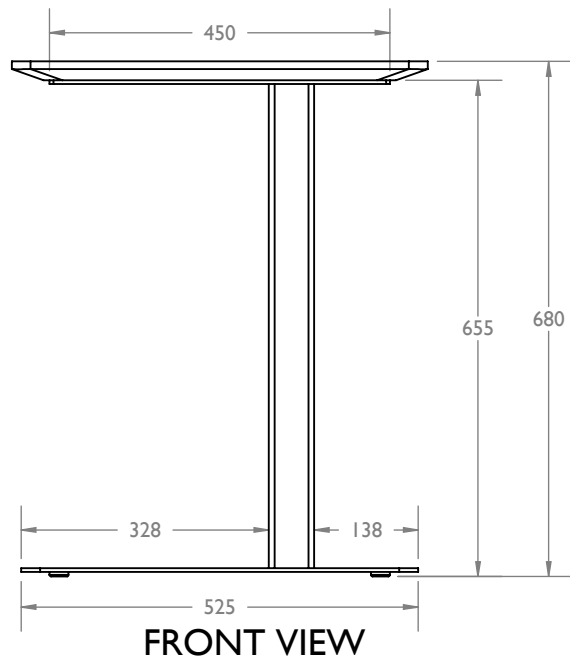
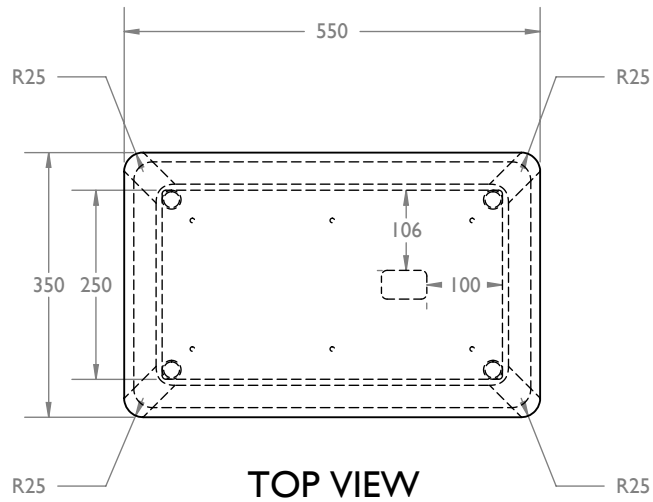

PRODUCT SPECIFICATION :		QTY:	FINISHING:
A	RECTANGULAR WORKTOP C/W CHAMFER EDGE & 4 ROUND CORNER (R25) 550L X 350D	1	WORKTOP: WHITE / WORKTOP ABS EDGING : BLACK
B	ANCHOR 01 BASE 655H	1	BLACK
TOTAL SETS: 2			PERSPECTIVE VIEW ALL DIMENSION IS IN MM



MATIC OFFICE SYSTEM SDN BHD (547300-D)
 45E-2A, (TINGKAT 2) BANGUNAN BANGSARIA
 Jalan Maarof, Bangsar Baru, Bangsar
 59000 Kuala Lumpur
 t. +60322012045 f. +60322016024
 urf. www.matic.com.my

CLIENT'S CONFIRMATION & APPROVAL

COMPANY : DMX GROUP (MALAYSIA) SDN BHD

REPRESENTATIVE NAME : JAMES

DATE : 06.06.2023

SIGNATURE & COMPANY STAMP

PROJECT INFORMATION :

DRAWING NO:011/22/R0

FURNITURE TYPE : ANCHOR

DRAWING TYPE : ITEM 11 - MEZZANINE

QUOTATION NO : M00234-23 R8

DRAWING INFORMATION :

DRAWN BY : FARAH

CHECKED BY: YIN QIAN

B.D. NAME : JEFT

PROJECT ID : MT23-P0110

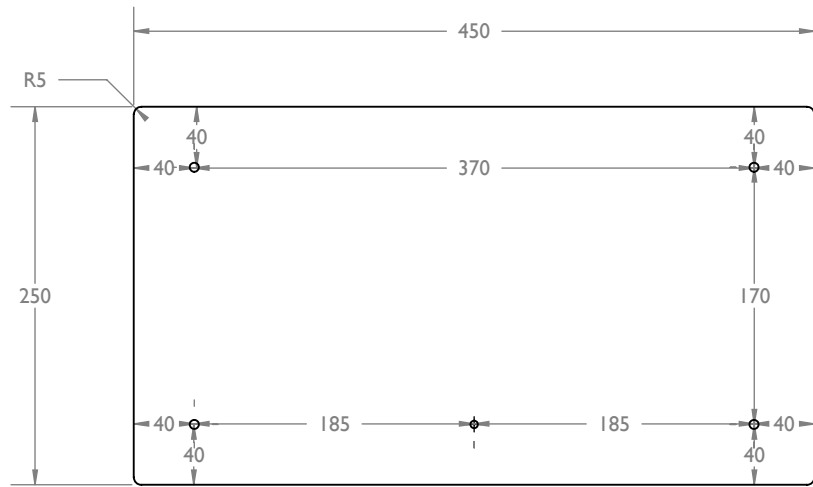

**THICKNESS 4MM
TOP PLATE CUTOUT VIEW**

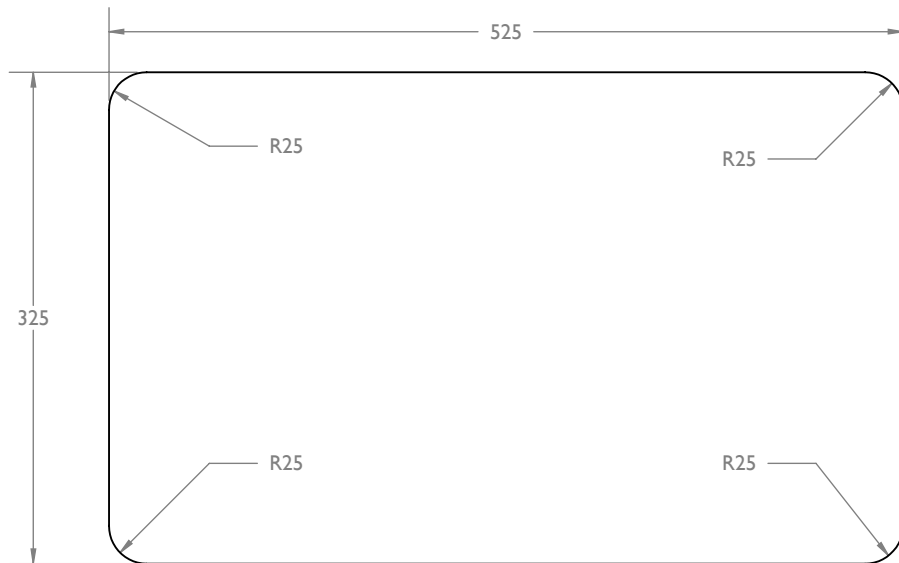

**THICKNESS 9MM
BOTTOM PLATE CUTOUT VIEW**

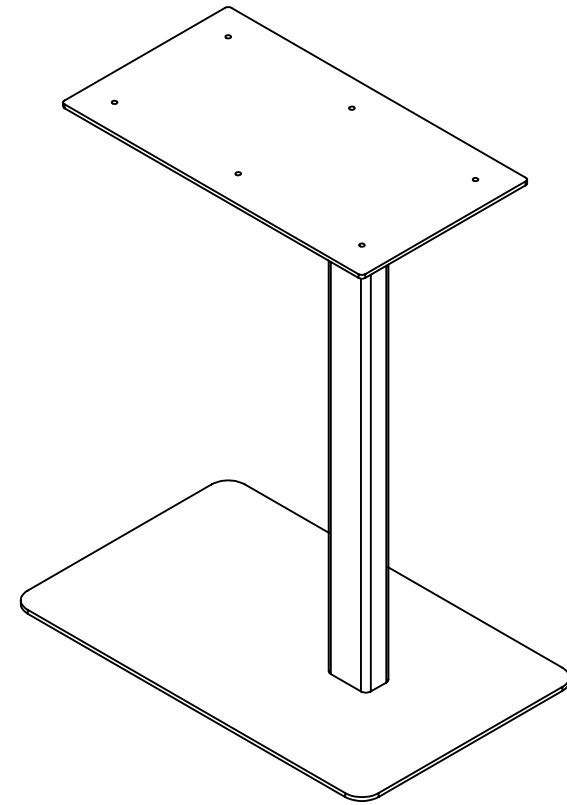

ISOMETRIC VIEW



MATIC OFFICE SYSTEM SDN BHD (547300-D)
 45E-2A, (TINGKAT 2) BANGUNAN BANGSARIA
 Jalan Maarof, Bangsar Baru, Bangsar
 59000 Kuala Lumpur
 t. +60322012045 f. +60322016024
 urf. www.matic.com.my

CLIENT'S CONFIRMATION & APPROVAL

COMPANY : DMX GROUP (MALAYSIA) SDN BHD

REPRESENTATIVE NAME : JAMES

DATE : 06.06.2023

SIGNATURE & COMPANY STAMP

PROJECT INFORMATION :

DRAWING NO:011/22/R0

FURNITURE TYPE : ANCHOR

DRAWING TYPE : DETAILED

QUOTATION NO : M00234-23 R8

DRAWING INFORMATION :

DRAWN BY : FARAH

CHECKED BY: YIN QIAN

B.D. NAME : JEFT

PROJECT ID : MT23-P0110