





STYLE #	19F-2570 MINI CROSSBODY	SEASON	MAY 2019 / Holiday
DESIGN#	YB257BX	GROUP	COBBLE HILL
ROUND	PROTO	DATE	3/18/2019
		FACTORY	YS

MATERIALS	STITCH
 BODY A	 6PLY - 8SPI
 TRIM	EDGE FINISH
 BOMBE FILLER	CUT EDGE W/ EDGE PAINT
 ULTRASUED LINING	TEMPER
	BODY : AS SAME AS REFERENCE SAMPLE

COMMENTS

- ALL EDGES ARE RAW EDGE W/ EDGE PAINT **unless indicated otherwise.**
- Please refer reference samples & images where applicable.

HARDWARE

BT0036 10.5mm
Ava Punk Chain



REVISION 1
CANCEL THE 2-TONE CANVAS LINING
ULTRASUED LINING AS
19F- 2441 ASTOR SQUARE CROSSBODY
PLEASE USE TRUFFLE A COLOR & QUALITY

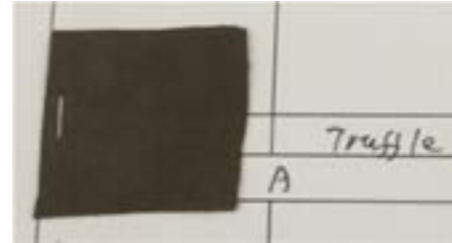

REVISION 2
CHANGE THE SIZE OF
O-RING FOR FUR HANDLE
PLEASE CHECK IF TOGGLE CAN BE DETACHABLE
IN 1.5CM RING
(IF NOT, PLEASE USE SMALLER TOGGLE)

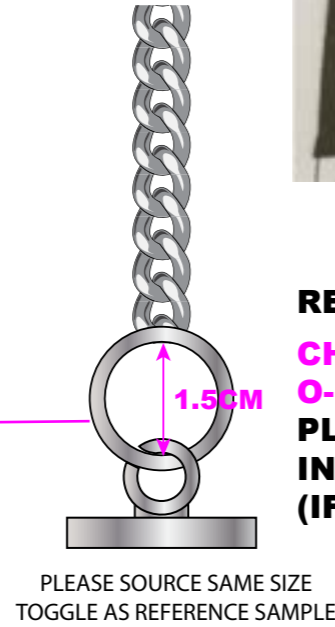

REVISION 3
FUR HANDLE DETAILS

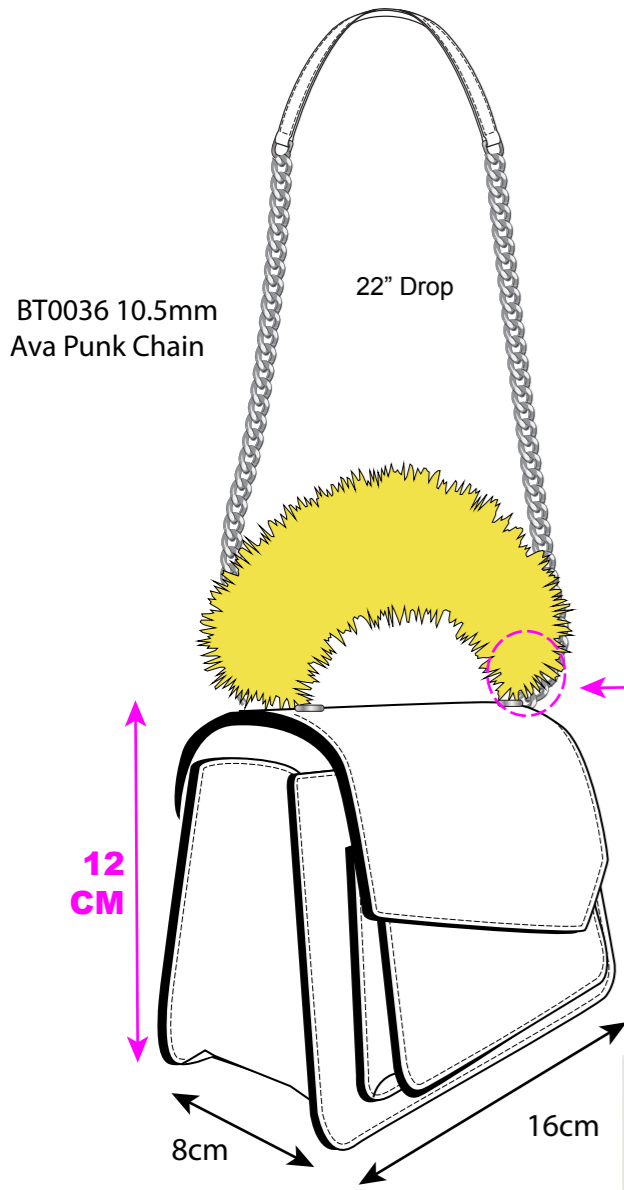
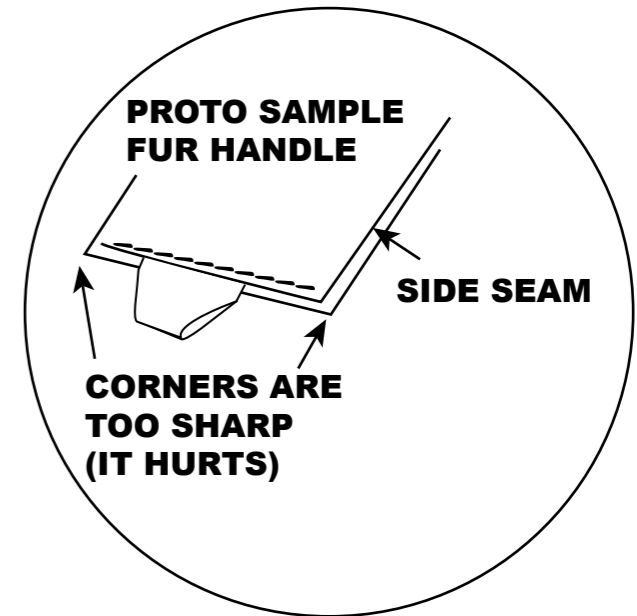
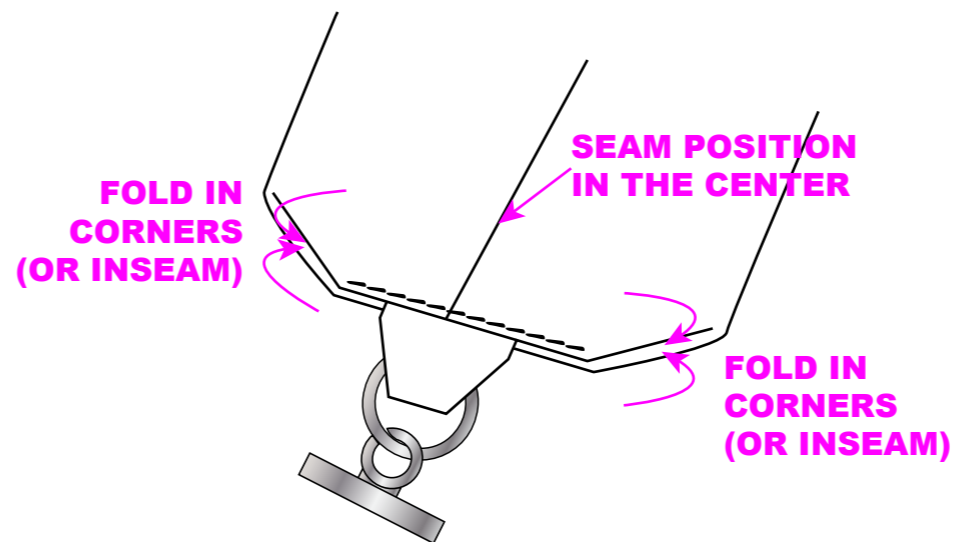

100% TO SCALE

REVISION 4

POCKET SIZE + FLAP POSITION CHANGE

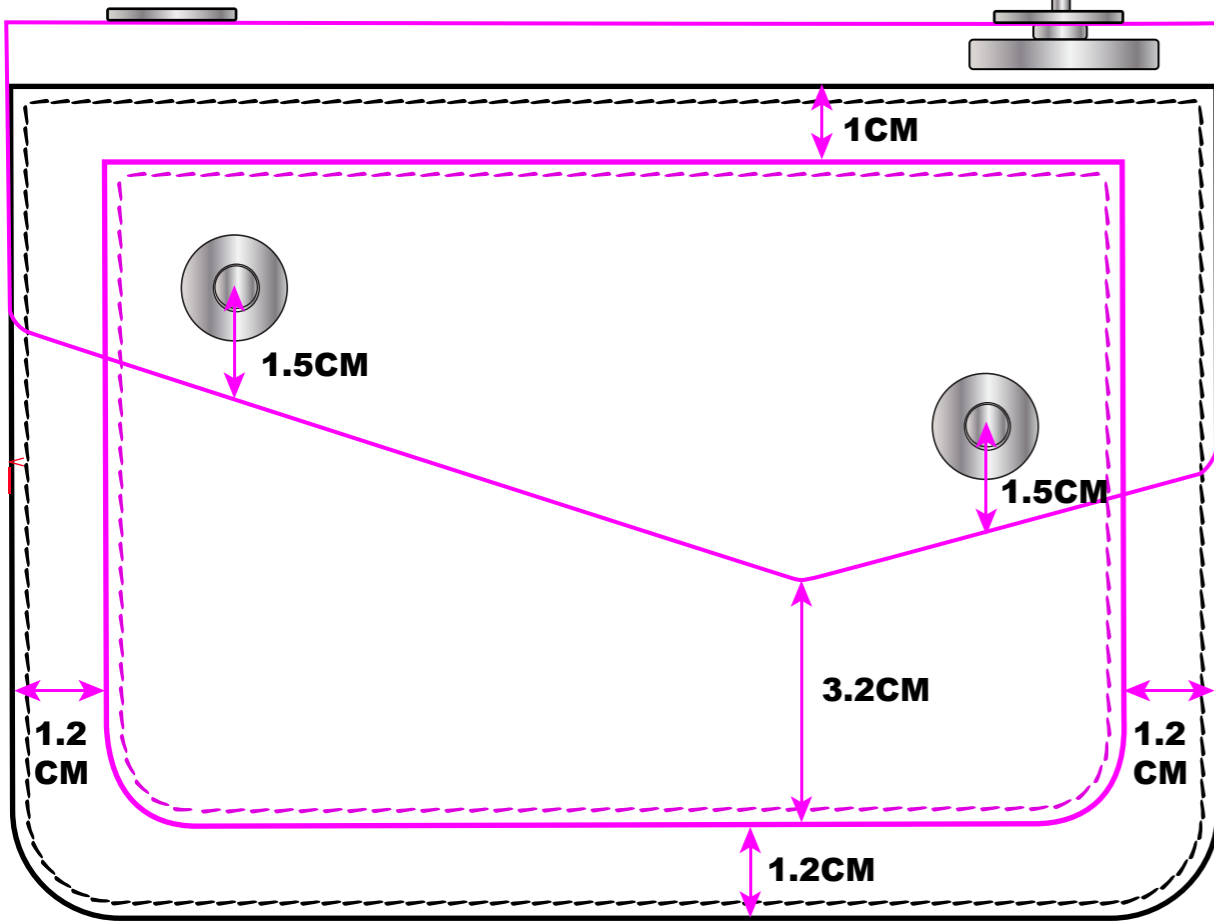

REVISION 5

FLAP HEIGHT CHANGE

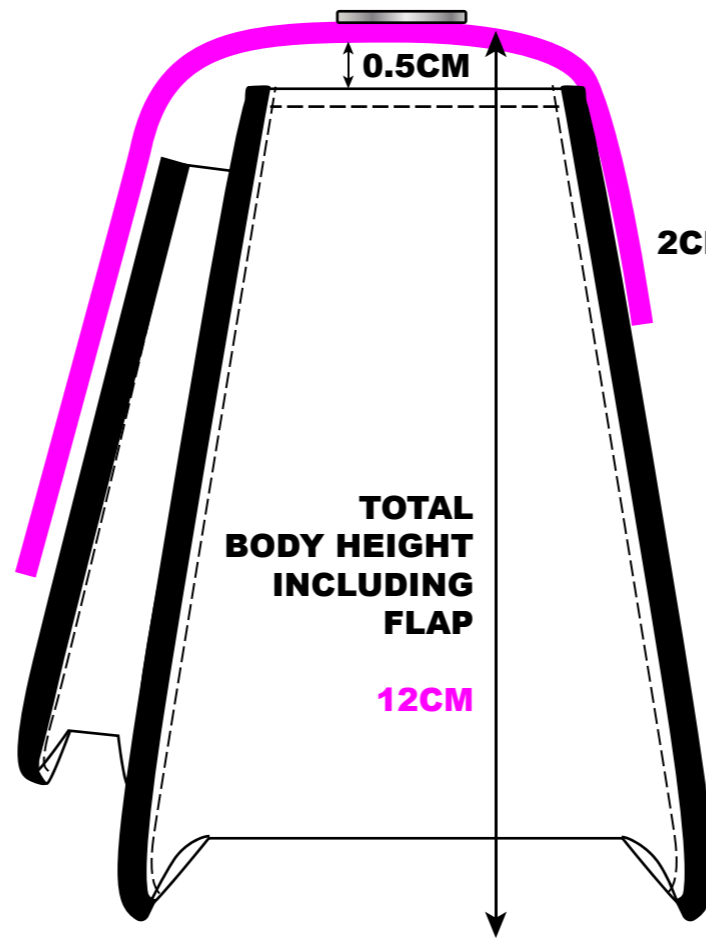

STYLE #	19F-2570 MINI CROSSBODY	SEASON	MAY 2019 / Holiday
DESIGN#	YB257BX	GROUP	COBBLE HILL
ROUND	PROTO	DATE	3/18/2019
		FACTORY	YS

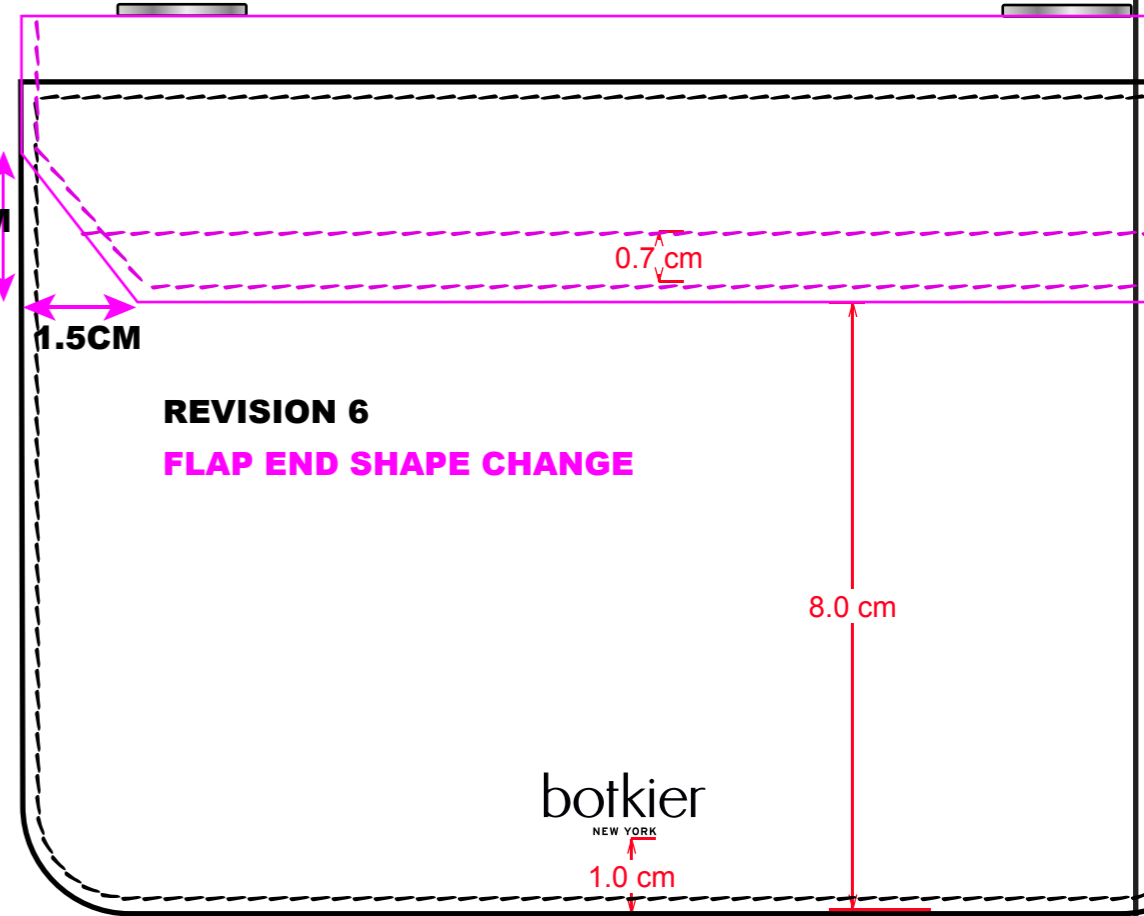

REVISION 6

FLAP END SHAPE CHANGE

PROTO SAMPLE COMMENT

1. PLEASE APPLY THE SAME ARCCODION CONSTRUCTION AS 19H-2083 COBBLE HILL CROSSBODY

2. PLEASE ADD PROPER INTERLINING TO THE BOTTOM

