

100% TO SCALE

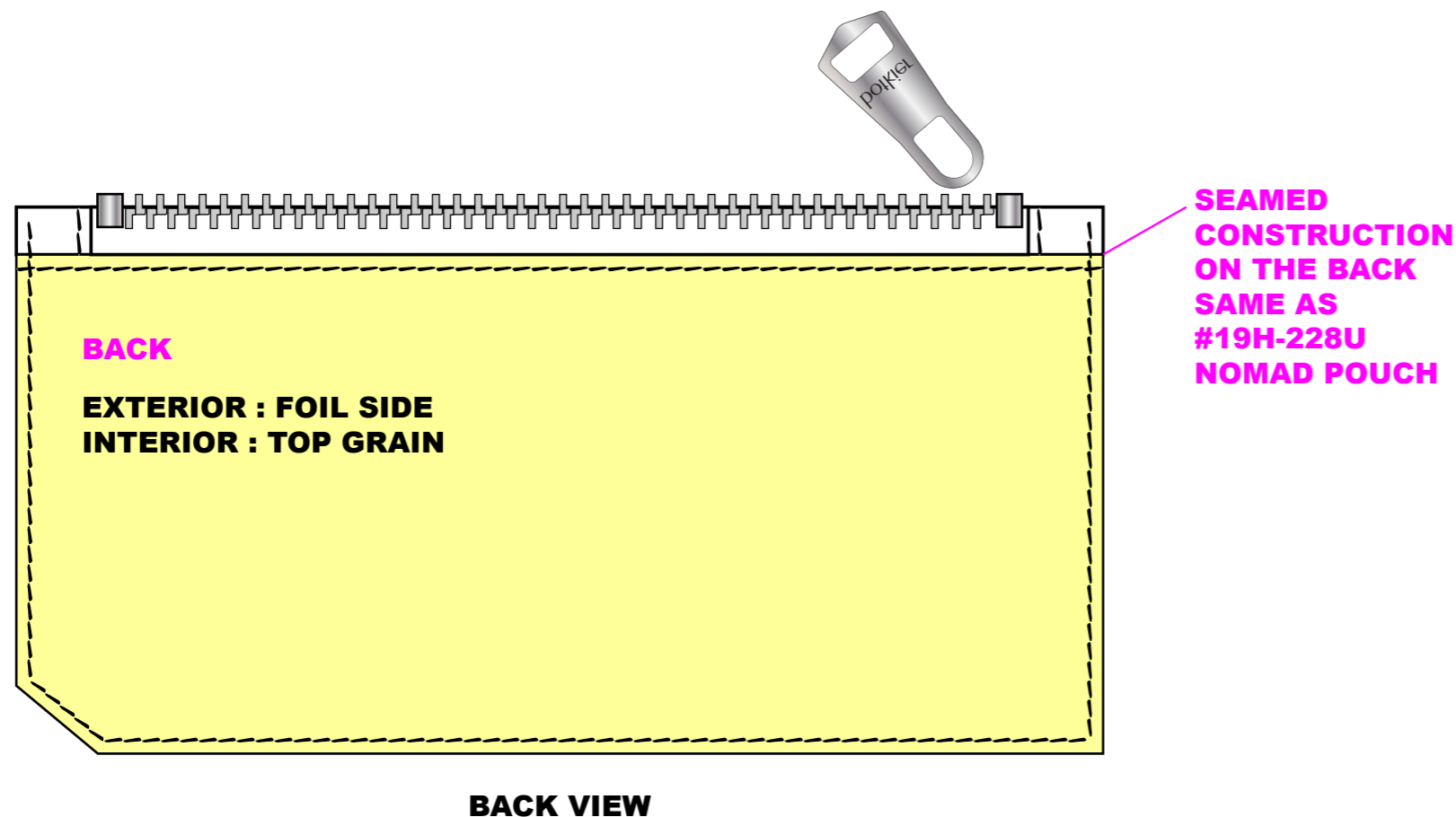
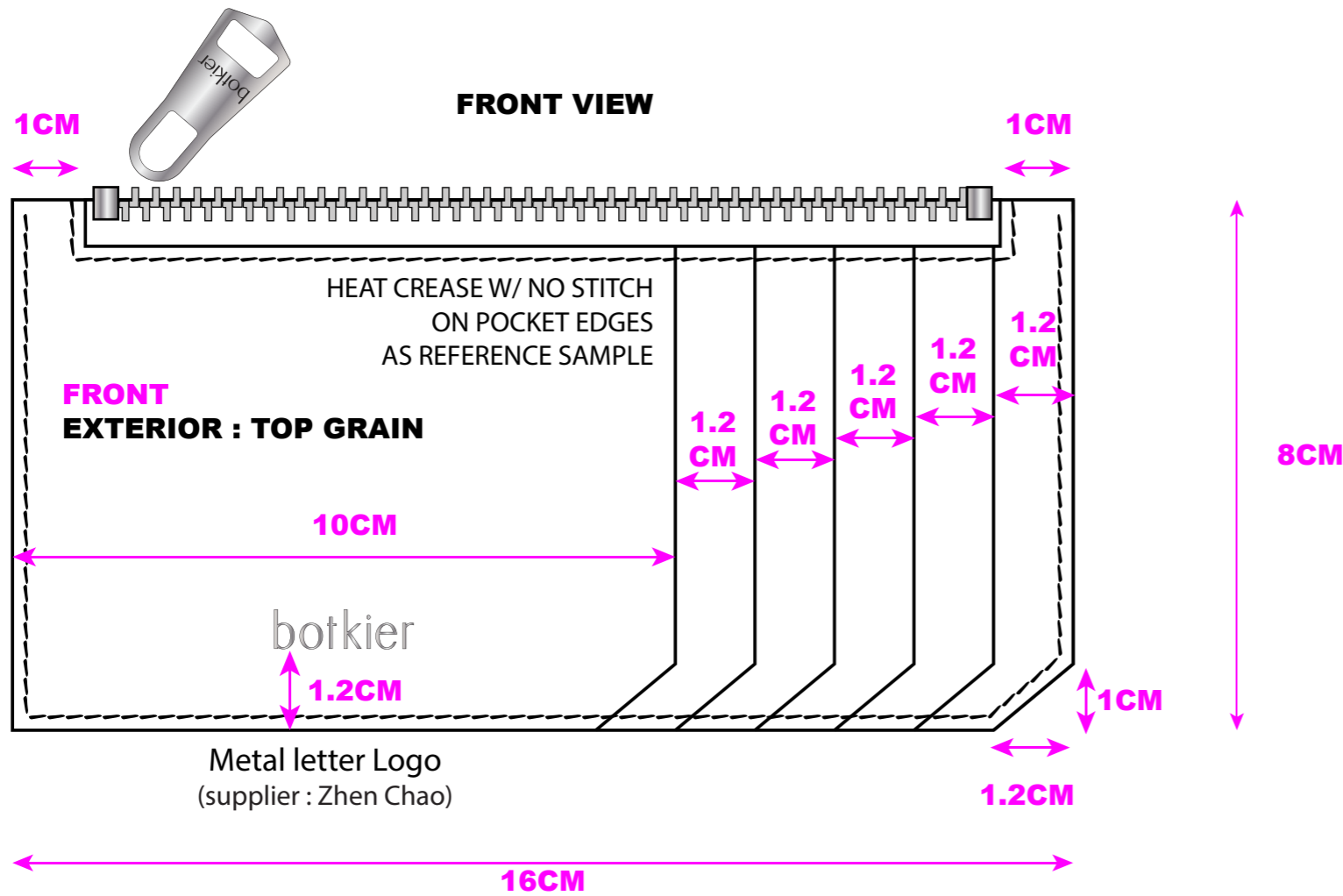

STYLE #	19H- 2280	SEASON	MAY MKT - HOLIDAY 19
DESIGN#	YS2280	GROUP	NOMAD
ROUND	PROTO	DATE	2/18/2019
		FACTORY	YS

<b>MATERIALS</b>	<b>STITCH</b>
BODY A (TOP GRAIN)	----- 6PLY - 8SPI
BODY B (FOIL SIDE)	<b>EDGE FINISH</b>
<b>PARTIALLY UN-LINED</b>	RAW EDGE W/ EDGE PAINT
	<b>TEMPER</b>
	BODY - SINGLE LAYER LEATHER CARD POCKETS - FABRIC LINING
<b>ZIPPER</b>	EXT : #3 METAL
<b>COMMENTS</b>	
- ALL EDGES ARE RAW EDGE W/ EDGE PAINT unless indicated otherwise. - Please refer reference samples & images where applicable.	

<b>HARDWARE</b>	HW-1838 zipper puller	HW: 1858 Metal letter Logo (supplier : Zhen Chao)
		botkier

REFERENCE/ORIGINAL SAMPLE

CARD POCKETS - FABRIC LINING BACKING

NO STITCH ON POCKET EDGE

**PLEASE REFER ALL DETAILS EXCEPT FOR ZIPPER PULLER & BACK BODY CONSTRUCTION**