

REVISION HISTORY			
REV	DESCRIPTION	DATE	APPROVED

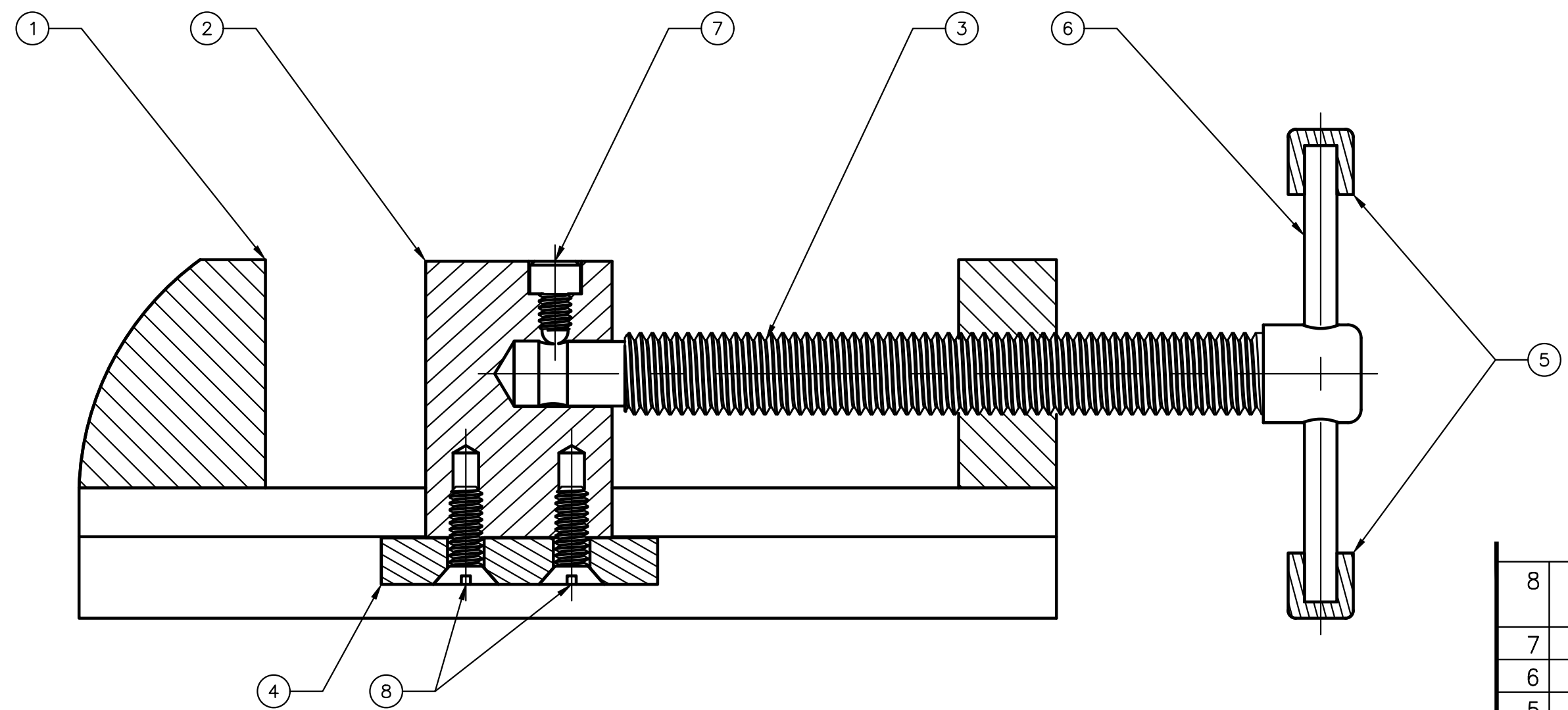

ITEM	QTY	DESCRIPTION	PART NO.
8	2	F.H. MACHINE SCREW .250-20 X .75 UNC-2B	
7	1	SET SCREW	SP20T4-7
6	1	HANDLE	SP20T4-6
5	2	END CAP	SP20T4-5
4	1	BOTTOM PLATE	SP20T4-4
3	1	MAIN SCREW	SP20T4-3
2	1	MOVEABLE JAW	SP20T4-2
1	1	WISE BODY	SP20T4-1
PARTS LIST			

- NOTES, UNLESS OTHERWISE SPECIFIED
1. INTERPRET DIMENSIONING AND TOLERANCING PER ASME Y14.5-2009
  2. REMOVE ALL BURRS AND SHARP EDGES
  3. MATERIAL:
  4. FILLETS AND ROUNDS TO BE R.12.
  5. ALL MACHINED SURFACES TO BE: 125/

		UNLESS OTHERWISE SPECIFIED DIMENSIONS ARE IN INCHES TOLERANCES ARE DECIMAL            ANGULAR .X     ±.1            ±.5° .XX    ±.01 .XXX   ±.005
		DRAWN BY: WARNER, KOLBY
NEXT ASSY	USED ON	COURSE: DES 2            CKD BY:
		MTG DAY: THU            SCORE:
APPLICATION		

**SIERRA COLLEGE**  
DRAFTING & ENGINEERING SUPPORT  
5000 ROCKLIN ROAD ROCKLIN, CA 95677

TITLE: ASSEMBLY SECTIONED

B	DATE	DWG. ASSIGNMENT NUMBER	REV
	SP 20		
SCALE 1:1	WEIGHT	SHEET	OF

PRODUCED BY AN AUTODESK STUDENT VERSION

PRODUCED BY AN AUTODESK STUDENT VERSION